

31 cm (12.1 inches), 800 × 600 pixels, 262,144 colors
High luminance, wide viewing angle, reversible scan direction

DESCRIPTION

The NL8060BC31-17 is a TFT (thin film transistor) active-matrix color liquid crystal display (LCD) module comprising an amorphous silicon TFT attached to each signal electrode, a driving circuit, and a backlight.

The NL8060BC31-17 has a built-in backlight. The backlight includes long-life replaceable lamps with a holder.

The 31 cm diagonal display area contains 800 × 600 pixels and can display 262,144 colors simultaneously.

The NL8060BC31-17 is suitable for industrial application use, because the viewing angle is wide and the luminance is high. Also, the viewing direction is selectable for either the upper or lower side by changing the scan direction.

FEATURES

- High luminance (350 cd/m², at I_L = 5mA rms/lamp)
- Wide viewing angle (with retardation film)
- Low reflection
- Reversible scan direction
- 6-bit digital RGB input signals
- Data enable (DE) function
- Smooth polarizer surface
- Edge-type backlight with two long-life lamps (one lamp holder)
- Replaceable lamp holder

APPLICATIONS

- Display terminals for control systems
- Monitors for process controllers

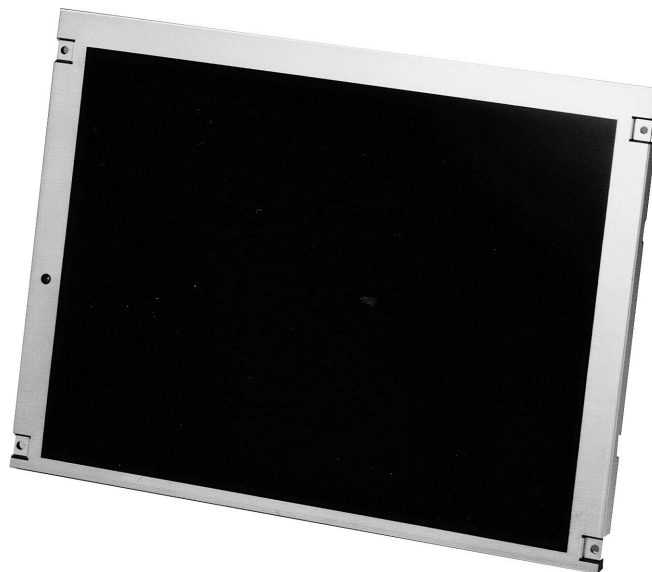

The information in this document is subject to change without notice.
Please confirm the delivery specification before starting to design your system.

STRUCTURE AND FUNCTION

A color TFT (thin film transistor) LCD module is comprised of a TFT liquid crystal panel structure, LSIs for driving the TFT array, and a backlight assembly. The TFT panel structure is created by sandwiching liquid crystal material in the narrow gap between a TFT array glass substrate and a color filter glass substrate. After the driver LSIs are connected to the panel, the backlight assembly is attached to the back side of the panel.

RGB (red, green, blue) data signals from a source system are modulated into a form suitable for active-matrix addressing by the onboard signal processor and sent to the driver LSIs, which in turn address the individual TFT cells.

Acting as an electro-optical switch, each TFT cell regulates light transmission from the backlight assembly when activated by the data source. By regulating the amount of light passing through the array of red, green, and blue dots, color images are created with clarity.

OUTLINE OF CHARACTERISTICS (at room temperature)

Item	Description
Display area	246.0 (H) × 184.5 (V) mm
Drive system	a-Si TFT active matrix
Display colors	262,144 colors
Number of pixels	800 × 600 pixels
Pixel arrangement	RGB vertical stripe
Pixel pitch	0.3075 (H) × 0.3075 (V) mm
Module size	280.0 (H) × 210.0 (V) × 13.0 (D) mm (typ.)
Weight	750 (typ.)
Contrast ratio	350:1 (typ.)
Viewing angle (more than the contrast ratio of 10:1)	Horizontal: 55° (typ. left side, right side) Vertical: 40° (typ. up side), 50° (typ. down side)
Designed viewing direction	<ul style="list-style-type: none"> • Wider viewing angle with contrast ratio: <ul style="list-style-type: none"> down side (6 o'clock, normal scan) up side (12 o'clock, reverse scan) • Wider viewing angle without image reversal: <ul style="list-style-type: none"> up side (12 o'clock, normal scan) down side (6 o'clock, reverse scan) • Optimum gray-scale ($\gamma = 2.2$): perpendicular
Color gamut	43% (typ. at center, to NTSC)
Response time	15 ms (typ.), "white 100%" to "black 10%"
Luminance	350 cd/m ² (typ.) (Lamp current: I _L = 5 mA rms per lamp)
Signal system	6-bit signals for each of RGB primary colors, synchronous signals (Hsync, Vsync), dot clock (CLK)
Supply voltage	3.3 V [5.0 V] (logic, LCD driving)
Backlight	Edge light type, two cold cathode fluorescent lamps in a holder <ul style="list-style-type: none"> • Lamp holder: Part No.121LHS15 • Recommended inverter: Part no. 121PW111
Power consumption	7.0 W (typ., at I _L = 5 mA rms/lamp)

BLOCK DIAGRAM

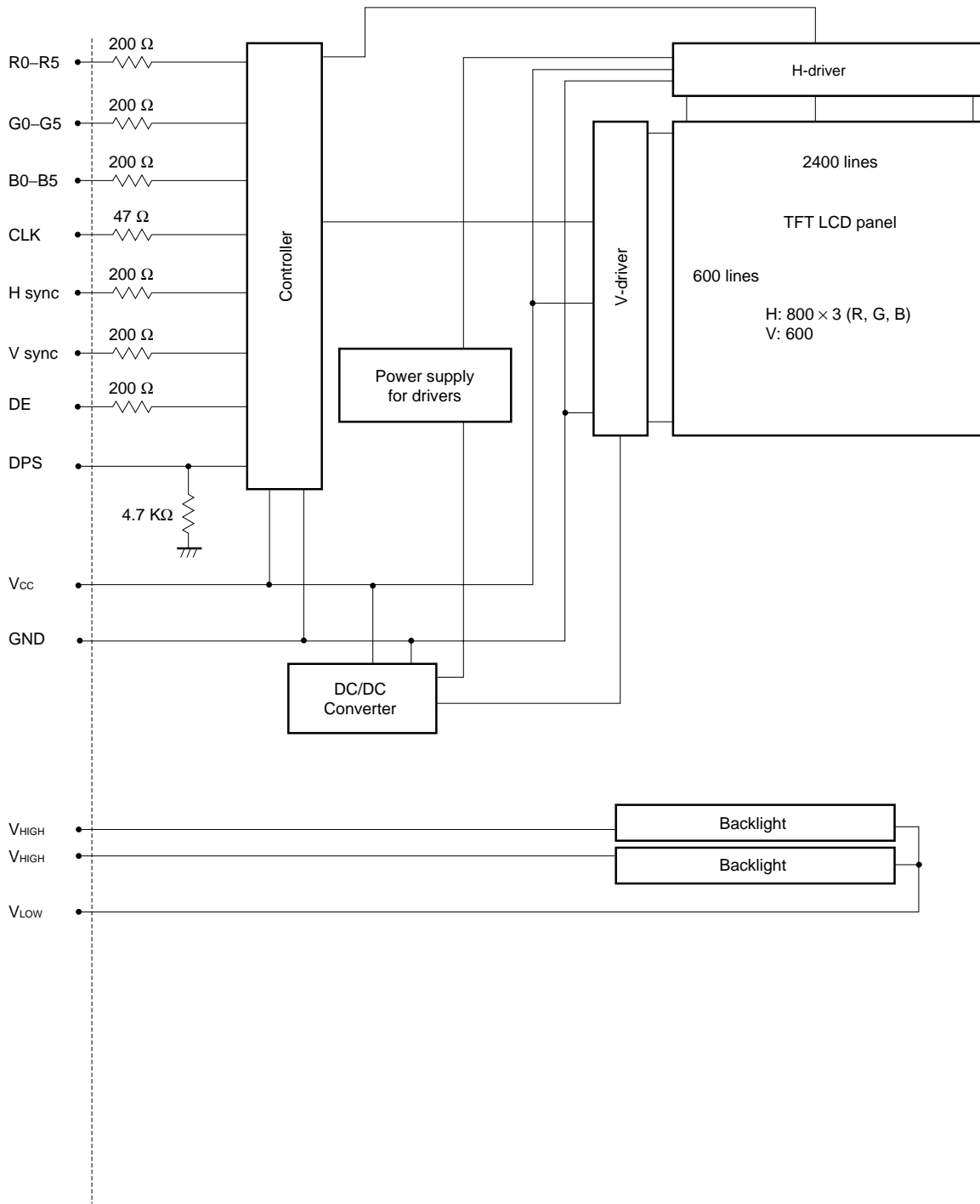

Note: GND is not connected to FG (frame ground) in the LCD module.

GENERAL SPECIFICATIONS

Item	Specification	Unit
Module size	280.0 ± 0.5 (H) × 210.0 ± 0.5 (V) × 13.7 max. (D)	mm
Display area	246.0 (H) × 184.5 (V) [diagonal display area: 31 cm (type 12.1)]	mm
Number of pixels	800 × 3 (H) × 600 (V)	pixel
Dot pitch	0.1025 (H) × 0.3075 (V)	mm
Pixel pitch	0.3075 (H) × 0.3075 (V)	mm
Pixel arrangement	RGB (red, green, blue) vertical stripe	–
Display colors	262,144	color
Weight	750 (typ.) 780 (max.)	g

ABSOLUTE MAXIMUM RATINGS

Parameter	Symbol	Rating	Unit	Remarks	
Supply voltage	V _{CC}	–0.3 to 6.5	V	T _a = 25°C	
Input voltage	V _I	–0.3 to V _{CC} + 0.3	V		
Lamp voltage	V _L	1800	V _{rms}		
Storage temp.	T _{ST}	–20 to 60	°C	–	
Operating temp.	T _{OP}	0 to 50	°C	Module surface ^{Note}	
Relative humidity (RH)		≤ 95	%	T _a ≤ 40°C	No condensation
		≤ 85	%	40 < T _a ≤ 50°C	
Absolute humidity		Absolute humidity shall not exceed T _a = 50°C, RH = 85%	g/m ³	T _a > 50°C	

Note: Measured at the panel surface (including self-heat)

ELECTRICAL CHARACTERISTICS

(1) Logic LCD Driving

T_a = 25°C

Parameter	Symbol	Min.	Typ.	Max.	Unit	Remarks
Supply voltage	V _{CC}	3.0 (4.75)	3.3 (5.0)	3.6 (5.25)	V	V _{CC} = 3.3 V (V _{CC} = 5.0 V)
Logic input “L” voltage	V _{IL}	0	–	V _{CC} × 0.3	V	CMOS level
Logic input “H” voltage	V _{IH}	V _{CC} × 0.7	–	V _{CC}	V	
Supply current	I _{CC}	– –	320 (240) ^{Note}	600 (500)	mA	V _{CC} = 3.3 V (V _{CC} = 5.0 V)

Note: Checker flag pattern (in EIAJ ED-2522)

(2) Backlight

Ta = 25°C

Parameter	Symbol	Min.	Typ.	Max.	Unit	Remarks
Lamp current	I _L	2.0 Note 1	5.0	5.5	mA rms	at a lamp
Lamp voltage	V _L	–	600	–	V rms	I _L = 5 mA
Lamp turn-on voltage Note 2	V _s	960	–	–	V rms	Ta = 25°C
		1200	–	–		Ta = 0°C
Oscillator frequency	F _t	58	65	69	kHz	Note 3

- Notes**
- In an atmosphere of below 10°C, keep the lamp current more than 3.0 mA rms in order to prevent the lamp from blinking.
 - The phase of the supply voltage for lamps must stay the same.
 - Recommended value of Ft.
 - Ft is within the specification.
 - and
 - $F_t = 1/4th \times (2n-1)$ th: Hsync period
n: a natural number (1, 2, 3...)
- If Ft is out of the recommended value, interference between the Ft frequency and Hsync frequency may cause beat on the display.

SUPPLY VOLTAGE SEQUENCE

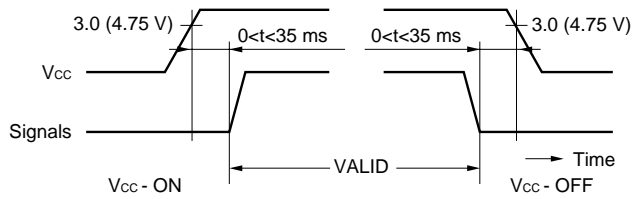

Signals: CLK, Hsync, Vsync, DE, R0–R5, G0–G5, B0–B5

- Notes:**
- The supply voltage for input signals should be the same as Vcc.
 - Turn on the backlight within the LCD operation period. When the backlight turns on before LCD operation or the LCD operation turns off before the backlight turns off, the display may momentarily become white.
 - When the power is off, please keep whole signals (Hsync, Vsync, CLK, DE, R0–R5, G0–G5, B0–B5) at a low level or high impedance.
 - The wrong power sequence may damage the module.
 - The signal should not be down during operation. Even if a signal could recover, the LCD module cannot be operated correctly and the display may be nonuniform. In case the signal is down, Vcc should be turned off, and then turned on with the signal as in the sequence above.

INTERFACE AND CONNECTOR PIN ASSIGNMENT

(1) Interface Signals, Power Supply

CN1: DF9-41P-1V (Hirose Electric Co., Ltd.)

Adaptable socket: DF9-41S-1V (Hirose Electric Co., Ltd.)

or

IL-310-T41S-VF (Japan Aviation Electronics Industry, Limited (JAE))

Pin No.	Symbol	Function
1	GND	Ground
2	CLK	Dot clock
3	GND	Ground
4	Hsync	Horizontal sync.
5	Vsync	Vertical sync.
6	GND	Ground
7	GND	Ground
8	GND	Ground
9	R0	Red data (LSB)
10	R1	Red data
11	R2	Red data
12	GND	Ground
13	R3	Red data
14	R4	Red data
15	R5	Red data (MSB)
16	GND	Ground
17	GND	Ground
18	GND	Ground
19	G0	Green data (LSB)
20	G1	Green data
21	G2	Green data

Pin No.	Symbol	Function
22	GND	Ground
23	G3	Green data
24	G4	Green data
25	G5	Green data (MSB)
26	GND	Ground
27	GND	Ground
28	GND	Ground
29	B0	Blue data (LSB)
30	B1	Blue data
31	B2	Blue data
32	GND	Ground
33	B3	Blue data
34	B4	Blue data
35	B5	Blue data (MSB)
36	GND	Ground
37	DE	Data enable signal Note 1
38	N.C.	No connection
39	V _{cc}	Power supply Note 3
40	V _{cc}	Power supply Note 3
41	DPS	Scan direction select Note 2

LSB: Least-Significant Bit
MSB: Most-Significant Bit

- Notes:**
- This function recognizes Fixed or DE mode when Vsync rises.
Low = DE mode
High = Fixed mode
 - DPS changes the scan direction (normal scan and reverse scan).
Low or Open = Normal scan
High = Reverse scan
See **DISPLAY POSITION** about the scan directions.

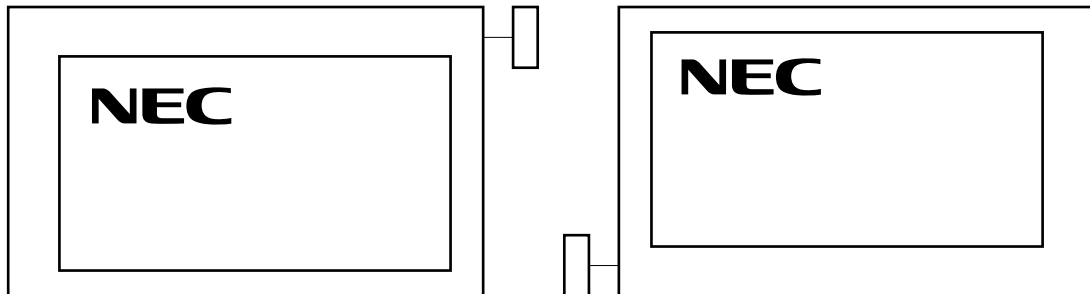

- All V_{cc} terminals should be connected to 3.3 V or 5.0 V.

(2) Lamp Connector

CN2: BHR-03VS-1
 Adaptable socket: SM03 (4.0) B-BHS-TB
 Supplier: J.S.T. Trading Company, Ltd.

Pin No.	Symbol	Function
1	V _{LOW}	Low-voltage terminal
2	V _{HIGH}	High-voltage terminal
3	V _{HIGH}	High-voltage terminal

Caution: V_H and V_L must be connected correctly. If you make a mistake in connection, you may get hurt and the module may break.

(3) Connection of Recommended Inverter: 121PW111

CN1
 Part no.: LZ-5P-SL-SMT
 Adaptable socket: LZ-5S-SC3
 Supplier: Japan Aviation Electronics Industry, Limited (JAE)

Pin No.	Symbol	Function
1	V _{DDB}	Power supply (12 V)
2	V _{DDB}	Power supply (12 V)
3	GNDB	Backlight ground
4	GNDB	Backlight ground
5	BRTHL	Luminance control Note

Note: BRTHL = High (+5 V) or open: High luminance (100%)
 BRTHL = Low (GNDB level): Low luminance (20%)

CN3
 Part no.: IL-Z-3PL-SMTY
 Adaptable socket: IL-Z-3S-S125C3
 Supplier: Japan Aviation Electronics Industry, Limited (JAE)

Pin No.	Symbol	Function
1	BRTC	Backlight On/Off signal Note 1
2	BRTH	Luminance control input Note 2
3	BRTL	Luminance control input Note 2

Notes: 1. BRTC = High (+5 V) or Open: Backlight on
 BRTC = Low (GNDB level): Backlight off

2. <1> Luminance control using a variable resistor

This method works when BRTHL (No.5 pin) of CN1 is opened.

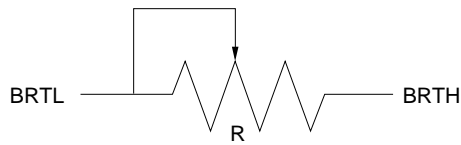

Mating variable resistor: 10 K Ω \pm 5 %

Minimum luminance (20%): R = 0 Ω

Maximum luminance (100%): R = 10 K Ω

<2> Luminance control by voltage

BRTHL and BRTHL are opened. The input voltage range between BRTH and GNDB is as follows.

Minimum luminance (20%, typ.): 3.45 V

Maximum luminance (100%): \leq 1.0 V

(4) Connector Location

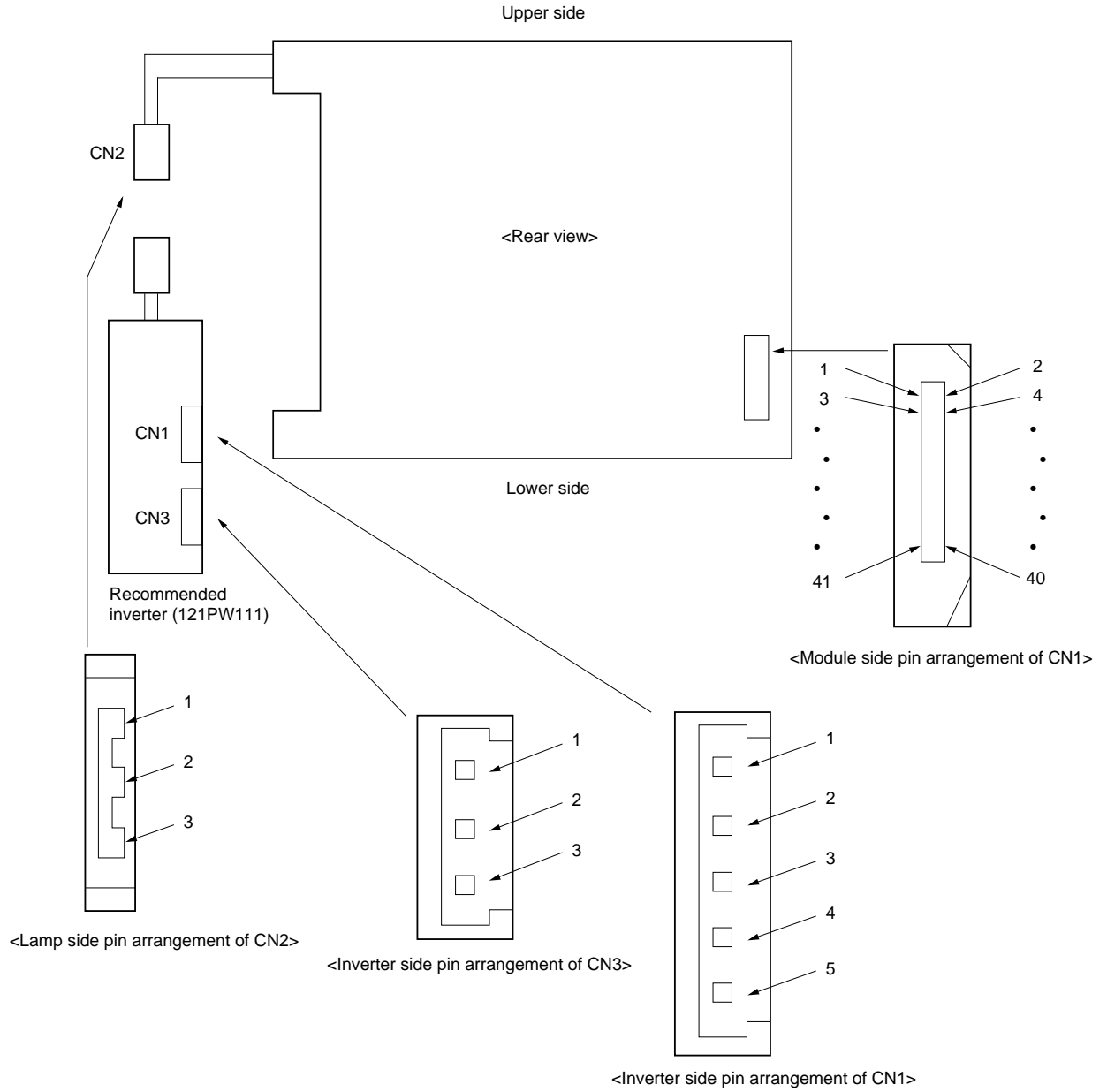

DISPLAY COLORS vs. INPUT DATA SIGNALS

Display Colors		Data Signal (0: Low Level; 1: High Level)																	
		R5	R4	R3	R2	R1	R0	G5	G4	G3	G2	G1	G0	B5	B4	B3	B2	B1	B0
Basic colors	Black	0	0	0	0	0	0	0	0	0	0	0	0	0	0	0	0	0	0
	Blue	0	0	0	0	0	0	0	0	0	0	0	0	1	1	1	1	1	1
	Red	1	1	1	1	1	1	0	0	0	0	0	0	0	0	0	0	0	0
	Magenta	1	1	1	1	1	1	0	0	0	0	0	0	1	1	1	1	1	1
	Green	0	0	0	0	0	0	1	1	1	1	1	1	0	0	0	0	0	0
	Cyan	0	0	0	0	0	0	1	1	1	1	1	1	1	1	1	1	1	1
	Yellow	1	1	1	1	1	1	1	1	1	1	1	1	0	0	0	0	0	0
	White	1	1	1	1	1	1	1	1	1	1	1	1	1	1	1	1	1	1
Red gray-scale	Black	0	0	0	0	0	0	0	0	0	0	0	0	0	0	0	0	0	0
		0	0	0	0	0	1	0	0	0	0	0	0	0	0	0	0	0	0
	Dark	0	0	0	0	1	0	0	0	0	0	0	0	0	0	0	0	0	0
	↑																		
	↓																		
	Bright	1	1	1	1	0	1	0	0	0	0	0	0	0	0	0	0	0	0
	1	1	1	1	1	0	0	0	0	0	0	0	0	0	0	0	0	0	
	1	1	1	1	1	1	0	0	0	0	0	0	0	0	0	0	0	0	
Green gray-scale	Black	0	0	0	0	0	0	0	0	0	0	0	0	0	0	0	0	0	0
		0	0	0	0	0	0	0	0	0	0	1	0	0	0	0	0	0	0
	Dark	0	0	0	0	1	0	0	0	0	1	0	0	0	0	0	0	0	0
	↑																		
	↓																		
	Bright	0	0	0	0	0	0	1	1	1	1	0	1	0	0	0	0	0	0
	0	0	0	0	0	0	1	1	1	1	1	0	0	0	0	0	0	0	
	0	0	0	0	0	0	1	1	1	1	1	1	0	0	0	0	0	0	
Blue gray-scale	Black	0	0	0	0	0	0	0	0	0	0	0	0	0	0	0	0	0	0
		0	0	0	0	0	0	0	0	0	0	0	0	0	0	0	0	0	1
	Dark	0	0	0	0	0	0	0	0	0	0	0	0	0	0	0	0	1	0
	↑																		
	↓																		
	Bright	0	0	0	0	0	0	0	0	0	0	0	0	1	1	1	1	0	1
	0	0	0	0	0	0	0	0	0	0	0	0	1	1	1	1	1	0	
	0	0	0	0	0	0	0	0	0	0	0	0	1	1	1	1	1	1	

Note: Colors are developed in combination with 6-bit signals (64 steps in gray-scale) of each primary red, green, and blue color. This process can result in up to 262,144 (64 × 64 × 64) colors.

INPUT SIGNAL TIMING

(1) Input Signal Specifications

Parameter		Symbol	Min.	Typ.	Max.	Unit	Remarks
CLK	Frequency	1/tc	34.0	38.362	40.0	MHz	26.067 ns (typ.)
	Duty	tch/tc	0.4	0.5	0.6	–	–
	Rise, fall	tcrf	–	–	10	ns	–
Hsync	Period	th	24.3	26.693	–	μs	37.463 kHz (typ.)
			829	1024	–	CLK	
	Display period	thd	800			CLK	–
	Front porch	thf	–	24	–	CLK	Fixed mode
			4	24	–	CLK	DE mode
	Pulse width	thp	12	72	127	CLK	Fixed mode
			12	72	–	CLK	DE mode
	Back porch	thb	73	128	198	CLK	Fixed mode
			13	128	509	CLK	DE mode
	thp + thb		200			CLK	Fixed mode
			25	200	511	CLK	DE mode
	CLK-Hsync timing	thch	10	–	–	ns	–
	Hsync-CLK timing	thcs	8	–	–	ns	–
	Hsync-Vsync timing	thv	1	–	–	CLK	–
Vsync-Hsync timing	tvS	15	–	–	ns	–	
Rise, fall	thrf	–	–	10	ns	–	
Vsync	Period	tv	16.1	16.683	17.2	ms	59.95 Hz (typ.)
			603	625	–	H	
	Display period	tvd	600			H	
	Front porch	tvf	–	1	–	H	Fixed mode
			1	1	–	H	DE mode
	Pulse width	tvp	1	2	23	H	Fixed mode
			1	2	–	H	DE mode
	Back porch	tvb	1	22	23	H	Fixed mode
			1	22	–	H	DE mode
	tvp + tvb		24			H	Fixed mode
2			24	254	H	DE mode	
Rise, fall	tvrf	–	–	10	ns	–	
DATA R0–R5 G0–G5 B0–B5	CLK-DATA timing	tds	8	–	–	ns	–
	DATA-CLK timing	tdh	10	–	–	ns	–
	Rise, fall	tdrf	–	–	10	ns	–
DE	DE-CLK timing	tes	8	–	–	ns	–
	CLK-DE timing	teh	10	–	–	ns	
	Rise, fall	terf	–	–	10	ns	

Note: All parameters should be kept in the specified range.

(2) Definition of Input Signal Timing

<Vertical>

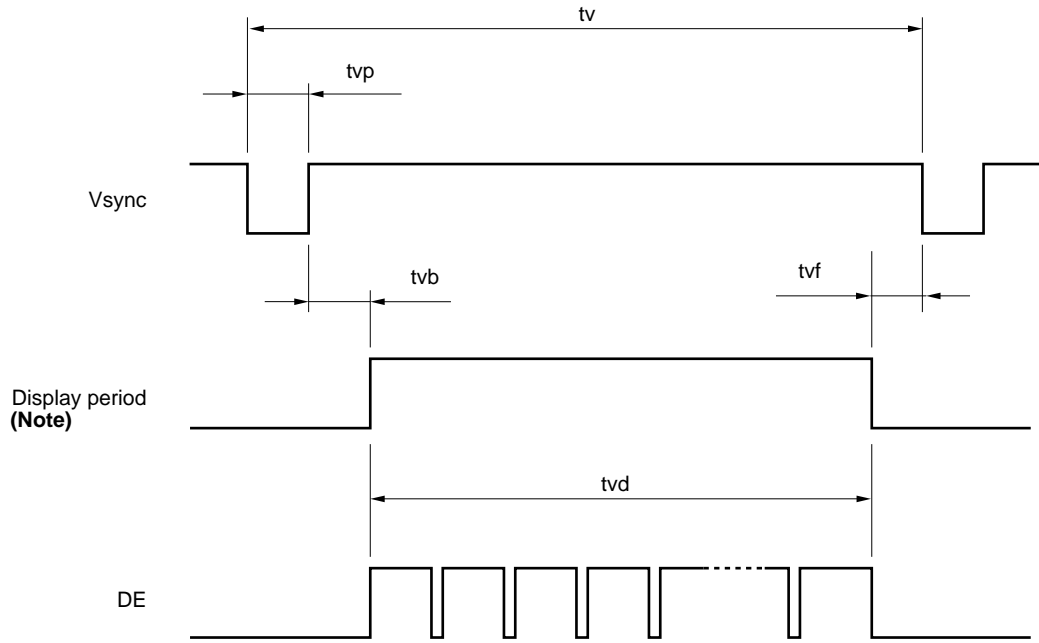

<Horizontal>

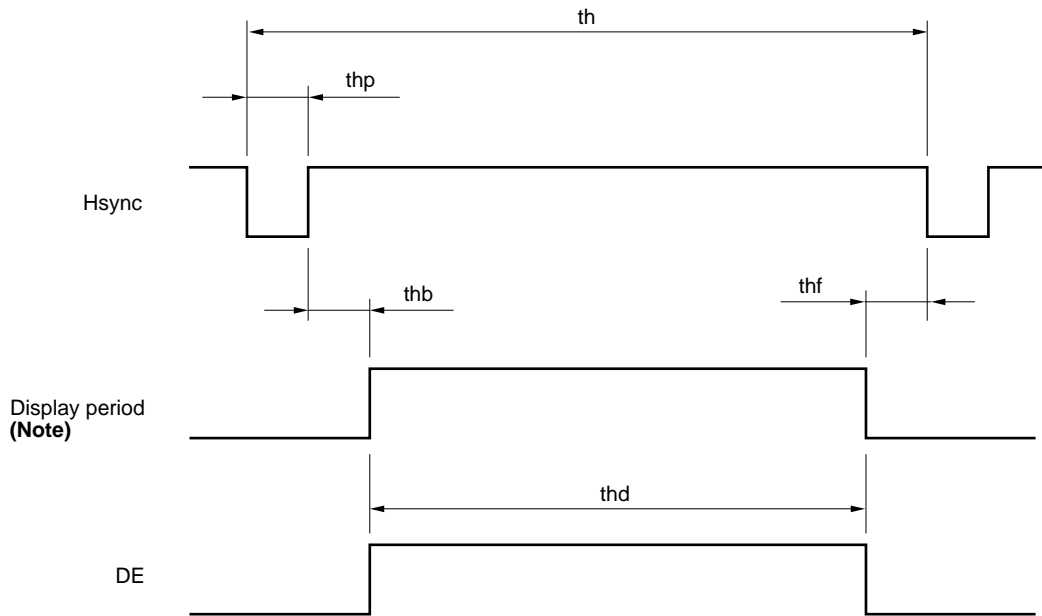

Note: These do not exist as signals.

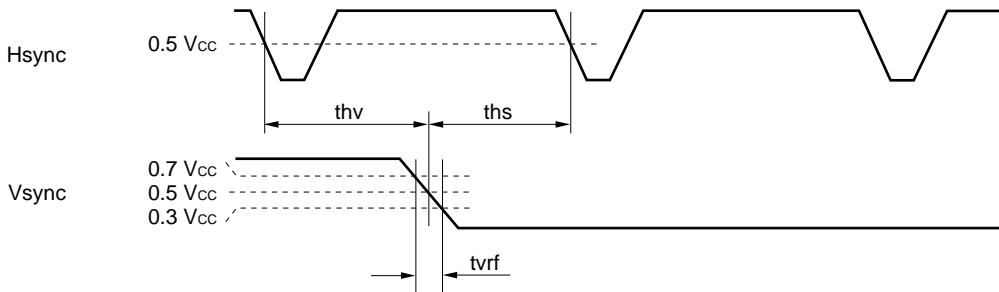
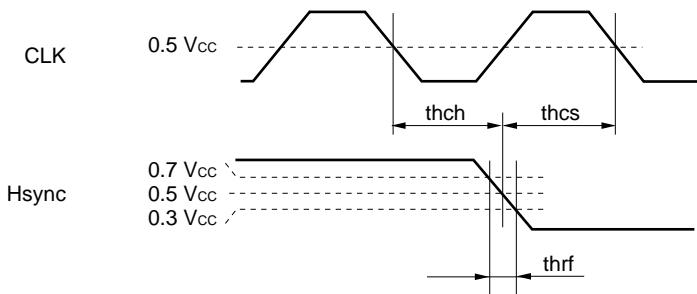
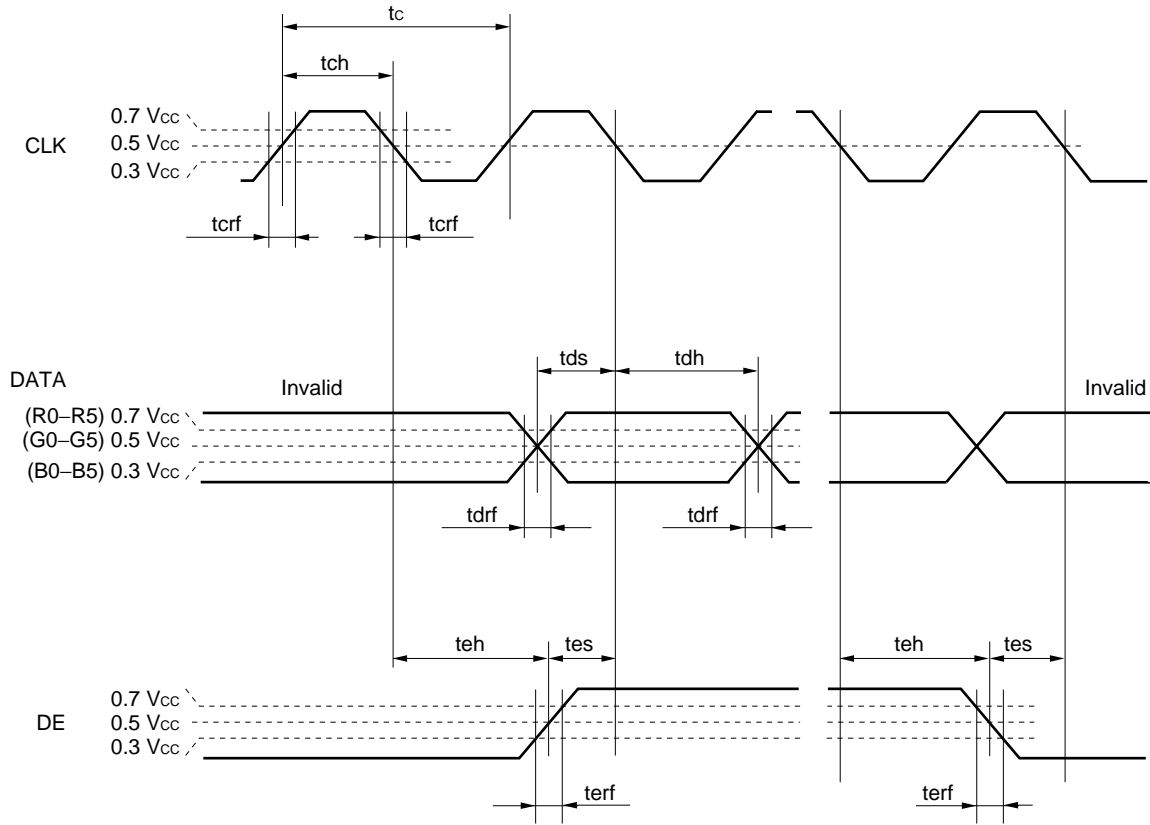

(3) Input Signal Timing Chart

a) Fixed timing mode

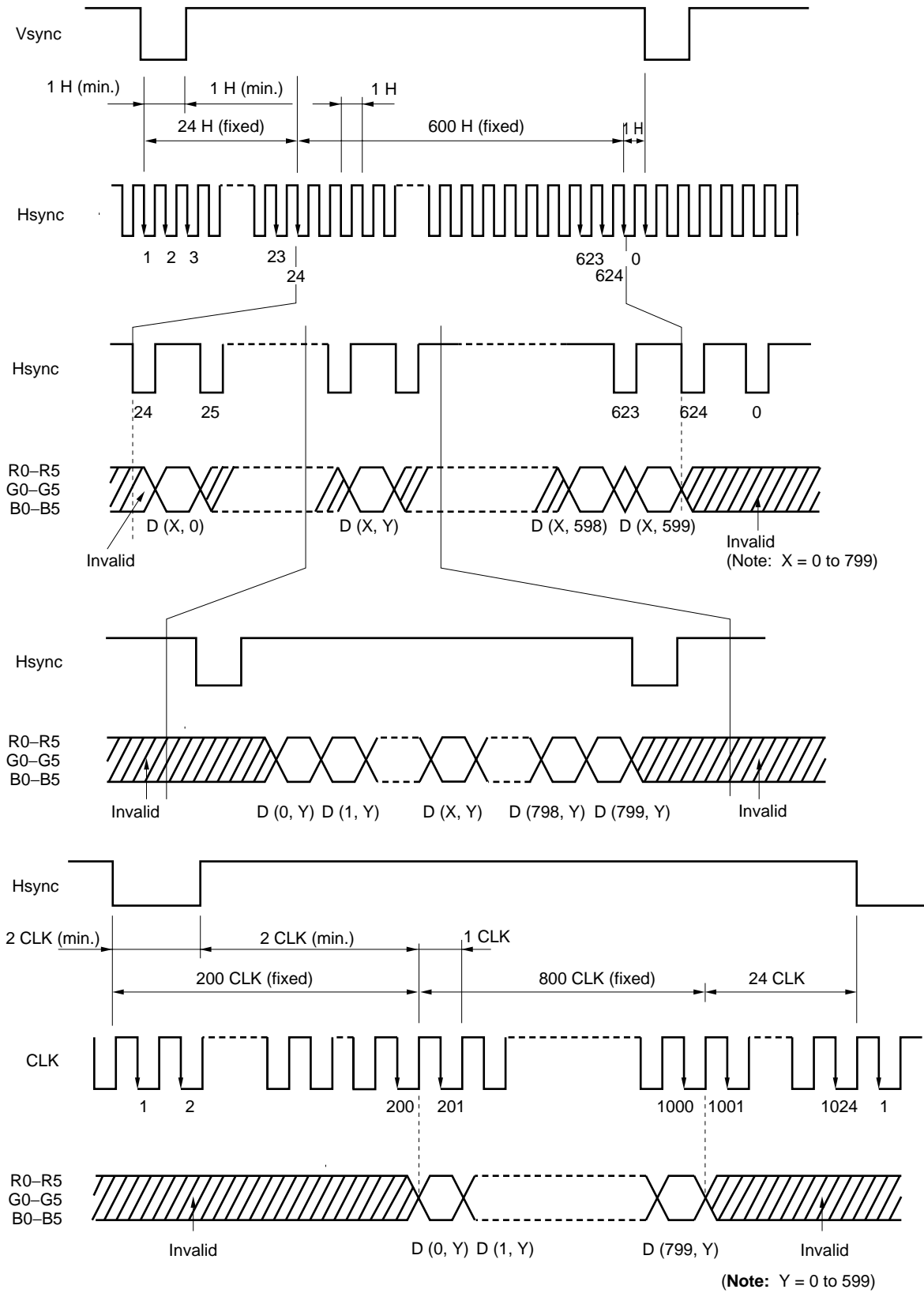

b) DE mode

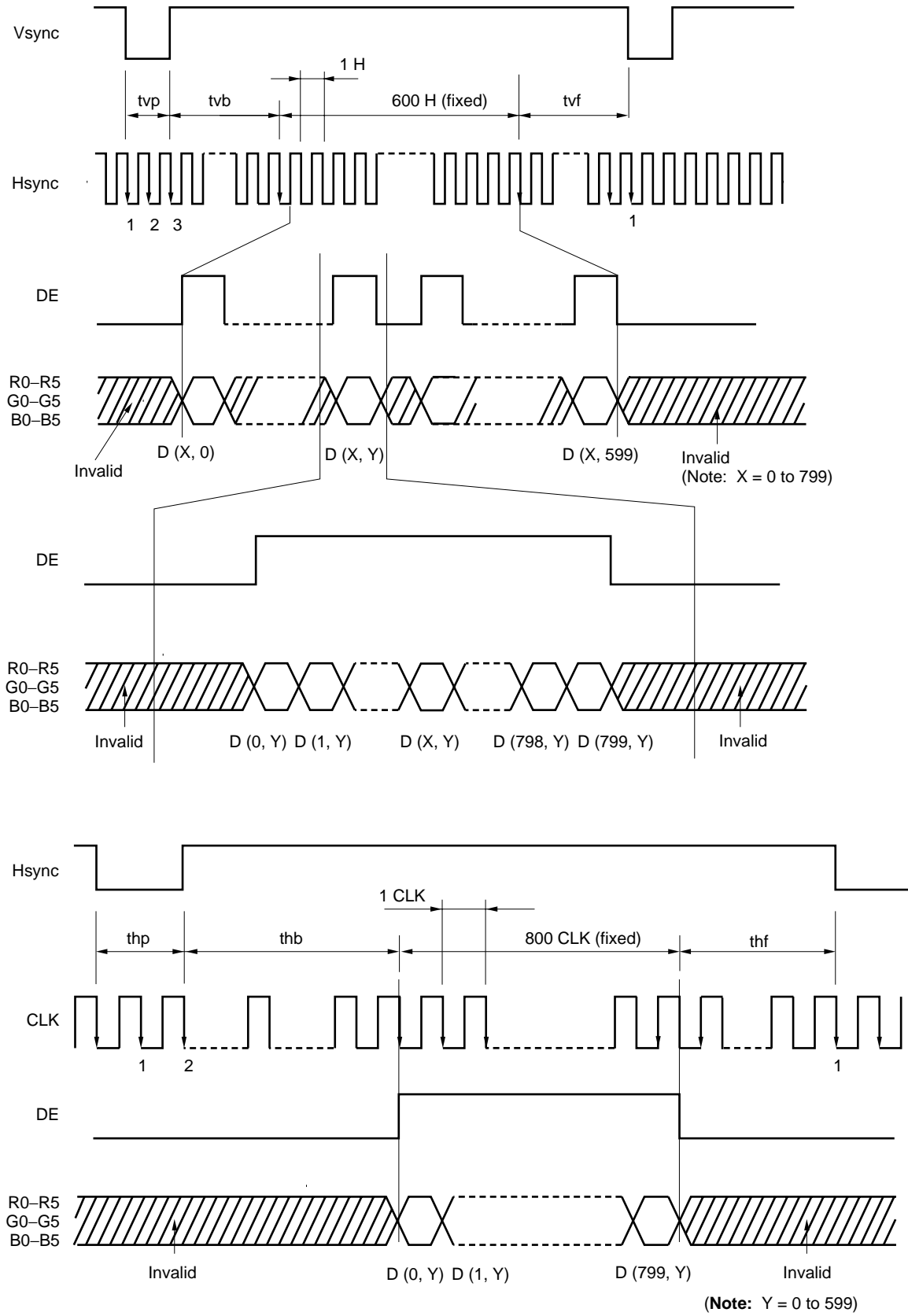

DISPLAY POSITION

Normal scan (DPS = "Low" or "Open")

D (0, 1)	D (1, 1)	-----	D (X, 1)	-----	D (798, 1)	D (799, 1)
D (0, 1)	D (1, 1)	-----	D (X, 1)	-----	D (798, 1)	D (799, 1)
		-----		-----		
D (0, Y)	D (1, Y)	-----	D (X, Y)	-----	D (798, Y)	D (799, Y)
		-----		-----		
D (0, 598)	D (1, 598)	-----	D (X, 598)	-----	D (798, 598)	D (799, 598)
D (0, 599)	D (1, 599)	-----	D (X, 599)	-----	D (798, 599)	D (799, 599)

Reverse scan (DPS = "High")

D (799,599)	D (798, 599)	-----	D (X, 599)	-----	D (1, 599)	D (0, 599)
D (799,598)	D (798, 598)	-----	D (X, 598)	-----	D (1, 598)	D (0, 598)
		-----		-----		
D (799, Y)	D (798, Y)	-----	D (X, Y)	-----	D (1, Y)	D (0, Y)
		-----		-----		
D (799, 1)	D (798, 1)	-----	D (X, 1)	-----	D (1, 1)	D (0, 1)
D (799, 0)	D (798, 0)	-----	D (X, 0)	-----	D (1, 0)	D (0, 0)

The drawings below show the relationship between the scan direction and the viewing direction.

Normal scan

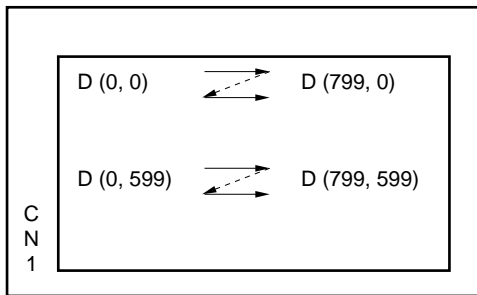

Reverse scan

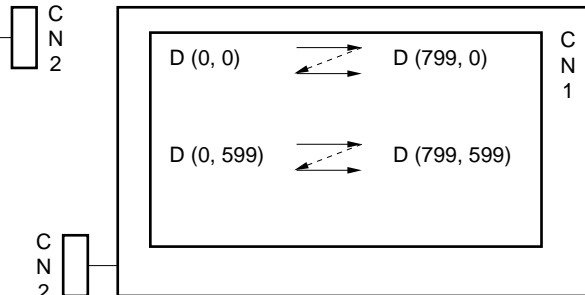

OPTICAL CHARACTERISTICS

Ta = 25°C Note 1

Item	Symbol	Conditions	Min.	Typ.	Max.	Unit	Remarks
Contrast ratio	CR	Note 2	200	350	–	–	Note 3
Luminance	Lumax	Note 2	270	350	–	cd/m ²	Note 4
Luminance uniformity	–	max./min.	–	–	1.4	–	Note 5

Reference data

Item	Symbol	Conditions	Min.	Typ.	Max.	Unit	Remarks	
Color gamut	C	at center, to NTSC	35	43	–	%	–	
Viewing angle range	Horizontal	θ_{x+}	CR > 10, $\theta_y = \pm 0^\circ$	45	55	–	deg.	Note 7
		θ_{x-}	CR > 10, $\theta_y = \pm 0^\circ$	45	55	–	deg.	
	Vertical	θ_{y+}	CR > 10, $\theta_x = \pm 0^\circ$	30	40	–	deg.	
		θ_{y-}	CR > 10, $\theta_x = \pm 0^\circ$	40	50	–	deg.	
Response time	t on	White to black 100% → 10%	–	15	40	ms	Note 6	
	t off	Black to white 0% → 90%	–	55	70	ms		

Notes: 1. Vcc = 3.3 V, IL = 5.0 mA rms, with recommended inverter part no. 121PW111.

2. Viewing angle: $\theta_x = \pm 0^\circ$, $\theta_y = \pm 0^\circ$, at center.

3. The contrast ratio is calculated by using the following formula.

$$\text{Contrast ratio (CR)} = \frac{\text{Luminance with all pixels in white}}{\text{Luminance with all pixels in black}}$$

The luminance is measured in a darkroom.

4. The luminance is measured after the module has been working for 20 minutes, with all pixels in white. Typical value is measured after luminance saturation. The luminance is measured in a darkroom.

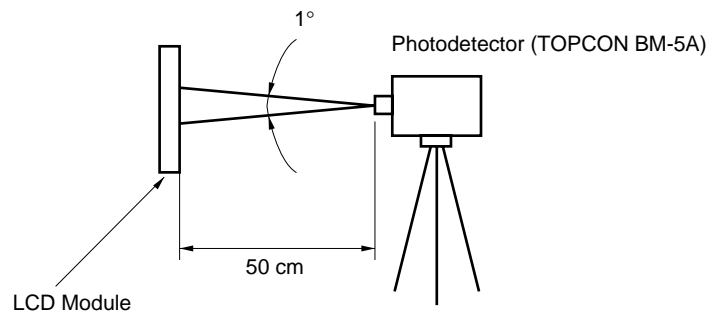

5. The luminance uniformity is calculated by using the following formula.

$$\text{Luminance uniformity} = \frac{\text{Maximum luminance}}{\text{Minimum luminance}}$$

The luminance is measured at or near the five points shown below.

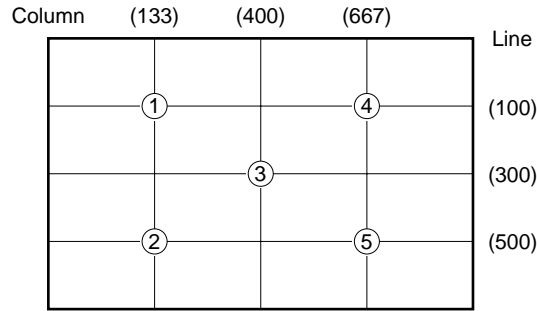

6. The definition of response time is as follows.

A photodetector output signal is measured when the luminance changes from white to black or from black to white.

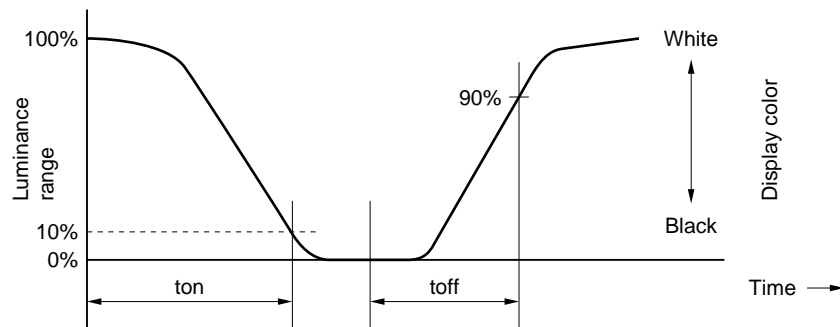

7. Definitions of viewing angle are as follows.

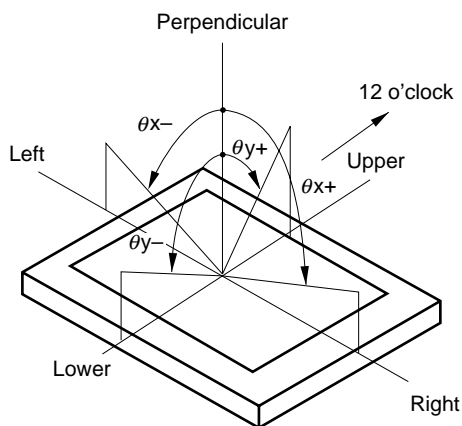

RELIABILITY TEST SPECIFICATIONS

Test Items	Test Conditions	Notes
High temperature/humidity operation	50 ±2°C, 85% relative humidity 240 hours Display data is black.	Note 1
Heat cycle (operation)	<1> 0°C ±3°C ... 1 hour 55°C ±3°C ... 1 hour <2> 50 cycles, 4 hours/cycle <3> Display data is black.	Note 1
Thermal shock (nonoperation)	<1> -20°C ±3°C ... 30 minutes 60°C ±3°C ... 30 minutes <2> 100 cycles <3> Temperature transition time within 5 minutes	Note 1
Vibration (nonoperation)	<1> 5 - 100 Hz, 19.6 m/s ² (2G) 1 minute/cycle X, Y, Z direction <2> 120 times each direction	Note 1 Note 2
Mechanical shock (nonoperation)	<1> 539 m/s ² (55G), 11 ms X, Y, Z direction <2> 5 times each direction	Note 1 Note 2
ESD (operation)	150 pF, 150 Ω, ±10 kV 9 places on a panel 10 times each place at one-second intervals	Note 1 Note 3
Dust (operation)	15 kinds of dust (JIS Z 8901) Hourly 15 seconds stir, 8 times repeat	Note 1

- Notes:**
1. The display function is checked by the same condition as the LCD module outgoing inspection.
 2. Physical damage.
 3. Discharge points are shown as follows.

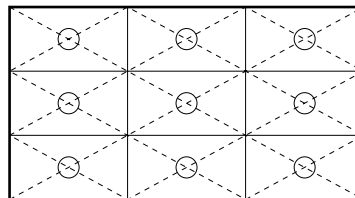

GENERAL CAUTIONS

The figures and statements below are very important. Please be sure you understand their contents.

	CAUTION	This figure is a mark that you will get hurt and/or the module will be damaged if you make a mistake in operation.
---	----------------	--

	This figure is a mark that you will get an electric shock if you make a mistake in operation.	
---	---	--

	This figure is a mark that you will get hurt if you make a mistake in operation.	
---	--	--

 **CAUTION**

	Do not touch an inverter on which there is a caution label, while the LCD module is in operation, because of dangerous high voltage.
---	--

(1) Caution when removing the module

- <1> Pick up the pouch only, when removing the module from a carrier box.

(2) Cautions for handling the module

- <1> As electrostatic discharges may break the LCD module, handle the LCD module with care against electrostatic discharges. Peel the protection sheet from the LCD panel surface as slowly as possible.
- <2>  As the LCD panel and backlight element are made from fragile glass material, impact and pressure to the LCD module should be avoided.
- <3> As the surface of the polarizer is very soft and easily scratched, use a soft dry cloth without chemicals for cleaning.
- <4> Do not pull the interface connectors in or out while the LCD module is operating.
- <5> Put the module display side down on a flat horizontal plane.
- <6> Handle connectors and cables with care.
- <7> When the module is operating, do not lose the CLK, Hsync, or Vsync signal. If any one of these signals is lost, the LCD panel would be damaged.
- <8> The torque on mounting screws should never exceed 0.294 N·m (3 kgf·cm).
- <9> Don't push or rub the surface of an LCD module. If you do, scratches or rubbing marks may be left on the surface of the module.
- <10> Do not stress interface connectors. The module may malfunction due to a defective contact and be damaged. Pay close attention to handling and orientation when matching connections.

(3) Cautions about atmosphere

- <1> Dew-drop atmosphere must be avoided.
- <2> Do not store and/or operate the LCD module in a high-temperature and/or high-humidity atmosphere. Storage in an anti-static pouch and at room temperature is recommended.
- <3> This module uses cold cathode fluorescent lamps. The lifetime of lamp is shortened if the module is operated in a low-temperature environment.
- <4> Do not operate the LCD module in a high magnetic field.

(4) Cautions regarding module characteristics

- <1> Do not apply fixed-pattern data for a long time to the LCD module. It may cause image sticking. Please use screen savers if the display pattern is fixed for a long time.
- <2> This module has retardation film, which may cause variation in color at different viewing angles. Nonuniformity may appear on the screen during high-temperature operation.
- <3> A light vertical stripe may be observed, depending on the display pattern. This is not a defect or a malfunction.
- <4> The noise from the inverter circuit may be observed in the luminance control mode. This is not a defect or a malfunction.

(5) Other cautions

- <1> Do not disassemble and/or reassemble the LCD module.
- <2> Do not readjust variable resistors or switches.
- <3> When returning the module for repair, etc., please pack it properly to avoid damage. We recommend using the original shipping packages.

The liquid crystal display has the following specific characteristics. These are not defects or malfunctions.

The optical characteristics of this module may be affected by the ambient temperature.

The LCD module uses a cold cathode tube for backlighting. Optical characteristics, like luminance or uniformity, will change over time.

Uneven brightness and/or small spots may be observed, depending on different display patterns.

OUTLINE DRAWING
FRONT SIDE (Unit: mm)

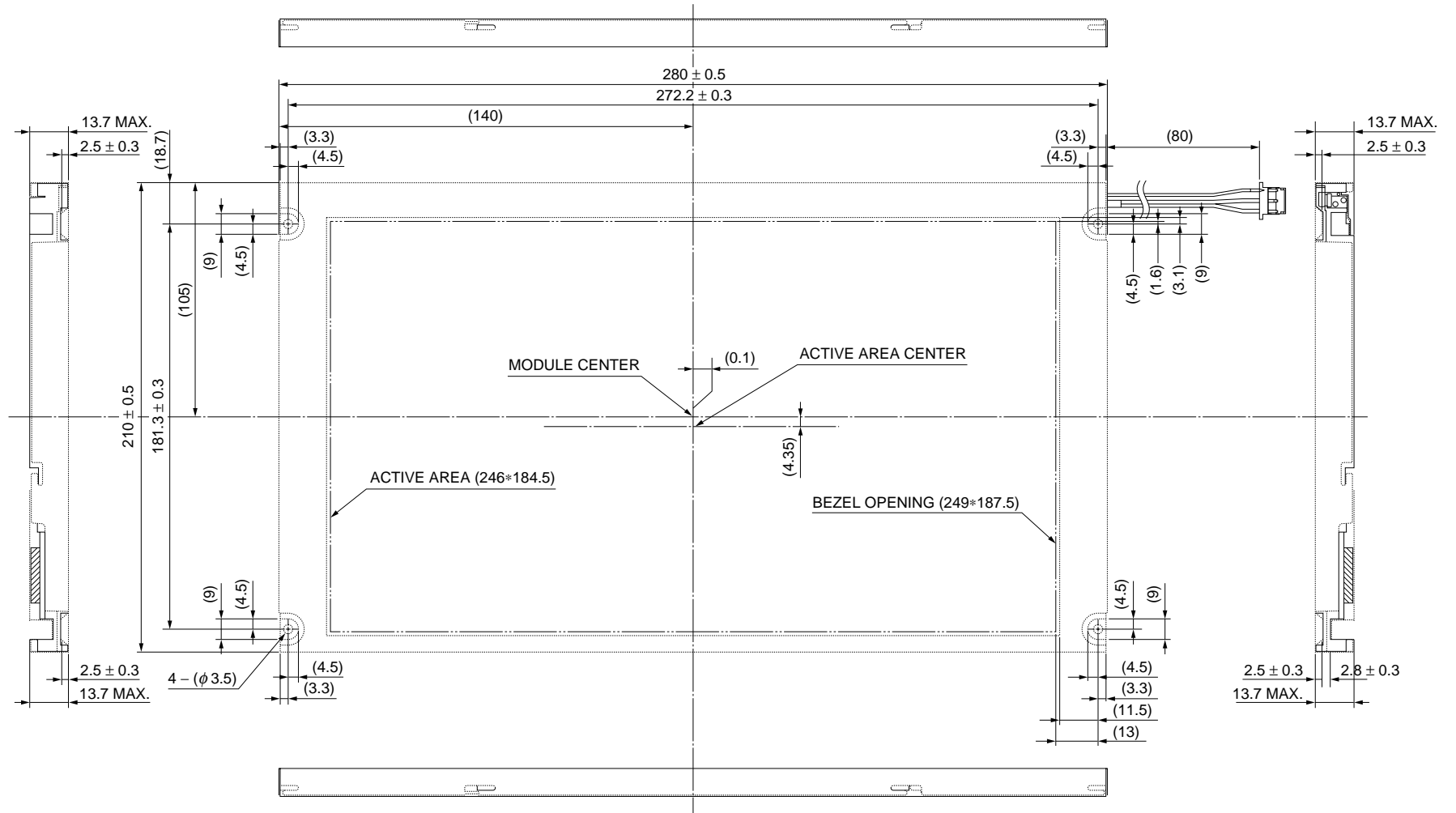

- Notes:**
1. The values in parentheses are for reference.
 2. The torque on a mounting screw should never exceed $0.294 \text{ N}\cdot\text{m}$ ($3 \text{ kgf}\cdot\text{cm}$).

OUTLINE DRAWING
 REAR SIDE (Unit: mm)

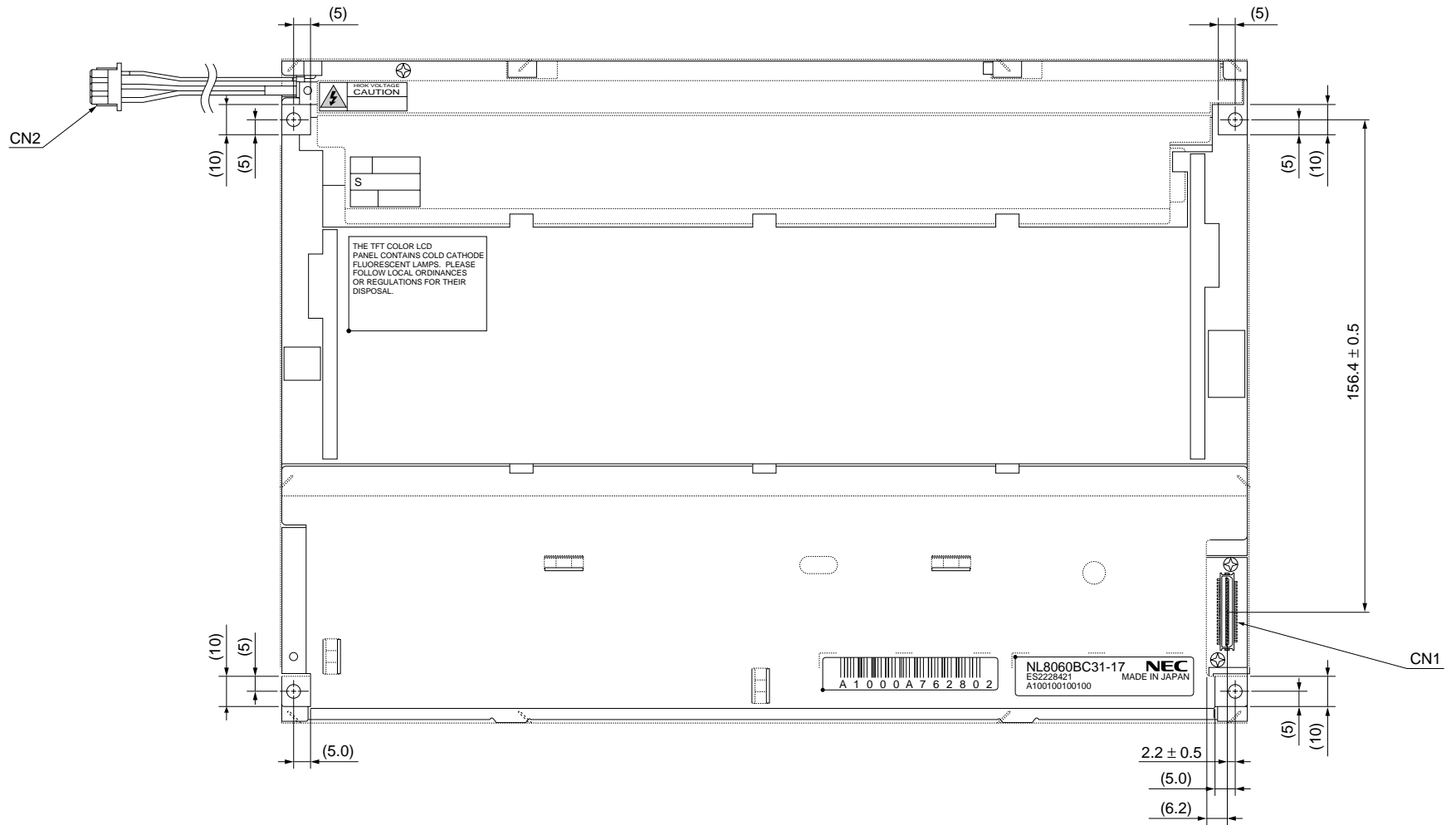

- Notes:**
1. The value in parentheses are for reference.
 2. The torque on a mounting screw should never exceed 0.294 N·m (3kgf·cm).

No part of this document may be copied or reproduced in any form or by any means without the prior written consent of NEC Corporation. NEC Corporation assumes no responsibility for any errors which may appear in this document.

NEC Corporation does not assume any liability for infringement of patents, copyrights or other intellectual property rights of third parties by or arising from use of a device described herein or any other liability arising from use of such device. No license, either express, implied or otherwise, is granted under any patents, copyrights or other intellectual property rights of NEC Corporation or others.

While NEC Corporation has been making continuous effort to enhance the reliability of its electronic components, the possibility of defects cannot be eliminated entirely. To minimize risks of damage or injury to persons or property arising from a defect in an NEC electronic component, customers must incorporate sufficient safety measures in its design, such as redundancy, fire-containment, and anti-failure features. NEC devices are classified into the following three quality grades:

"Standard," "Special," and "Specific". The Specific quality grade applies only to devices developed based on a customer designated "quality assurance program" for a specific application. The recommended applications of a device depend on its quality grade, as indicated below. Customers must check the quality grade of each device before using it in a particular application.

Standard: Computers, office equipment, communications equipment, test and measurement equipment, audio and visual equipment, home electronic appliances, machine tools, personal electronic equipment and industrial robots

Special: Transportation equipment (automobiles, trains, ships, etc.), traffic control systems, anti-disaster systems, anti-crime systems, safety equipment and medical equipment (not specifically designed for life support)

Specific: Aircrafts, aerospace equipment, submersible repeaters, nuclear reactor control systems, life support systems or medical equipment for life support, etc.

The quality grade of NEC devices is "Standard" unless otherwise specified in NEC's Data Sheets or Data Books. If customers intend to use NEC devices for applications other than those specified for Standard quality grade, they should contact an NEC sales representative in advance.

(Note)

(1) "NEC" as used in this statement means NEC Corporation and also includes its majority-owned subsidiaries.

(2) "NEC electronic component products" means any electronic component product developed or manufactured by or for NEC (as defined above).