



Fast, Low-Voltage, 4Ω, 4-Channel CMOS Analog Multiplexer

MAX4634

General Description

The MAX4634 fast, low-voltage, 4-channel CMOS analog multiplexer features 4Ω (max) on-resistance (RON). It offers RON matching between switches to 0.3Ω (max) and RON flatness of 1Ω (max) over the specified signal range. Each switch can handle V+ to GND analog signals. Off-leakage current is only 0.1nA (max) at +25°C. The MAX4634 features fast turn-on (tON) and turn-off (tOFF) times of 18ns and 11ns, respectively. All this comes in the tiny 10-pin μMAX® and 10-pin, 3mm x 3mm, TDFN packages.

This low-voltage multiplexer operates from a +1.8V to +5.5V single supply. All digital inputs have +0.8V and +2.4V logic thresholds, ensuring TTL/CMOS-logic compatibility with +5V operation.

Applications

- Battery-Operated Equipment
- Audio and Video Signal Routing
- Low-Voltage Data-Acquisition Systems
- Sample-and-Hold Circuits
- Communications Circuits

μMAX is a registered trademark of Maxim Integrated Products, Inc.

Features

- ◆ **Guaranteed RON**
2.5Ω (typ) with 5V Supply
4.5Ω (typ) with 3V Supply
- ◆ **0.3Ω (max) Guaranteed RON Match Between Channels**
- ◆ **1Ω (max) Guaranteed RON Flatness Over Signal Range**
- ◆ **0.1nA (at +25°C) Guaranteed Low Leakage Currents**
- ◆ **+1.8V to +5.5V Single-Supply Operation**
- ◆ **+1.8V Operation**
RON = 30Ω (typ) Overtemperature
tON = 30ns (typ), tOFF = 13ns (typ)
- ◆ **V+ to GND Signal Handling**
- ◆ **TTL/CMOS-Logic Compatible**
- ◆ **-78dB Crosstalk (at 1MHz)**
- ◆ **-80dB Off-Isolation (at 1MHz)**
- ◆ **0.018% Total Harmonic Distortion**

Ordering Information

PART	TEMP RANGE	PIN-PACKAGE	TOP MARK
MAX4634EUB	-40°C to +85°C	10 μMAX	—
MAX4634ETB	-40°C to +85°C	10 TDFN-EP* (3mm x 3mm)	AAU

*EP = Exposed pad.

Pin Configurations/Functional Diagrams/Truth Table

TOP VIEW

MAXIM
MAX4634EUB

μMAX

A1	A0	EN	ON SWITCH
X	X	0	NONE
0	0	1	1
0	1	1	2
1	0	1	3
1	1	1	4

X = DON'T CARE

MAXIM
MAX4634ETB

TDFN

*EP = EXPOSED PAD



For pricing, delivery, and ordering information, please contact Maxim Direct at 1-888-629-4642, or visit Maxim's website at www.maxim-ic.com.

Fast, Low-Voltage, 4Ω, 4-Channel CMOS Analog Multiplexer

ABSOLUTE MAXIMUM RATINGS

(Voltages referenced to GND.)

V+-0.3V to +6V
A ₋ , EN, COM, NO ₋ (Note 1)-0.3V to (V+ + 0.3V)
Continuous Current (all other pins)±20mA
Continuous Current (COM, NO ₋)±50mA
Peak Current (COM, NO ₋ pulsed at 1ms, 10% duty cycle)±100mA

Continuous Power Dissipation (T_A = +70°C)

10-Pin μMAX (derate 4.1mW/°C above +70°C)330mW
10-Pin TDFN (derate 24.4mW/°C above +70°C)1951mW
Operating Temperature Range-40°C to +85°C
Storage Temperature Range-65°C to +150°C
Lead Temperature (soldering, 10s)+300°C

Note 1: Signals on NO₋, COM, EN, or A₋ exceeding V+ or GND are clamped by internal diodes. Limit forward diode current to maximum current rating.

Stresses beyond those listed under "Absolute Maximum Ratings" may cause permanent damage to the device. These are stress ratings only, and functional operation of the device at these or any other conditions beyond those indicated in the operational sections of the specifications is not implied. Exposure to absolute maximum rating conditions for extended periods may affect device reliability.

ELECTRICAL CHARACTERISTICS—Single +5V Supply

(V+ = +4.5V to +5.5V, V_{IH} = 2.4V, V_{IL} = 0.8V, T_A = -40°C to +85°C, unless otherwise noted. Typical values are at V+ = +5V, T_A = +25°C.) (Notes 2, 3)

PARAMETER	SYMBOL	CONDITIONS	MIN	TYP	MAX	UNITS	
ANALOG SWITCH							
Analog Signal Range	V _{COM} , V _{NO-}		0		V+	V	
On-Resistance	R _{ON}	V+ = 4.5V, I _{COM} = 10mA, V _{NO-} = 0 to V+	T _A = +25°C	2.5	4	Ω	
			T _A = T _{MIN} to T _{MAX}		4.5		
On-Resistance Match Between Channels (Notes 4, 5)	ΔR _{ON}	V+ = 4.5V, I _{COM} = 10mA, V _{NO-} = 0 to V+	T _A = +25°C	0.1	0.3	Ω	
			T _A = T _{MIN} to T _{MAX}		0.4		
On-Resistance Flatness (Note 6)	R _{FLAT(ON)}	V+ = 4.5V, I _{COM} = 10mA, V _{NO-} = 0 to V+	T _A = +25°C	0.75	1	Ω	
			T _A = T _{MIN} to T _{MAX}		1.2		
NO ₋ Off-Leakage Current (Note 7)	I _{NO-(OFF)}	V+ = 5.5V; V _{COM} = 1V, 4.5V; V _{NO-} = 4.5V, 1V	T _A = +25°C	-0.1	±0.01	+0.1	nA
			T _A = T _{MIN} to T _{MAX}	-0.3		+0.3	
COM Off-Leakage Current (Note 7)	I _{COM(OFF)}	V+ = 5.5V; V _{COM} = 1V, 4.5V; V _{NO-} = 4.5V, 1V	T _A = +25°C	-0.1	±0.01	+0.1	nA
			T _A = T _{MIN} to T _{MAX}	-0.65		+0.65	
COM On-Leakage Current (Note 7)	I _{COM(ON)}	V+ = 5.5V; V _{COM} = 1V, 4.5V; V _{NO-} = 1V, 4.5V, or unconnected	T _A = +25°C	-0.1	±0.01	+0.1	nA
			T _A = T _{MIN} to T _{MAX}	-0.65		+0.65	
DIGITAL I/O (A₋, EN)							
Input Logic-High	V _{IH}		2.4			V	
Input Logic-Low	V _{IL}				0.8	V	
Input Logic Current			-100	5	+100	nA	

Fast, Low-Voltage, 4Ω, 4-Channel CMOS Analog Multiplexer

MAX4634

ELECTRICAL CHARACTERISTICS—Single +5V Supply (continued)

(V₊ = +4.5V to +5.5V, V_{IH} = 2.4V, V_{IL} = 0.8V, T_A = -40°C to +85°C, unless otherwise noted. Typical values are at V₊ = +5V, T_A = +25°C.) (Notes 2, 3)

PARAMETER	SYMBOL	CONDITIONS	MIN	TYP	MAX	UNITS
DYNAMIC						
Turn-On Time (Note 7)	t _{ON}	V _{NO_} = 3V, R _L = 300Ω, C _L = 35pF, Figure 2	T _A = +25°C	14	18	ns
			T _A = T _{MIN} to T _{MAX}		20	
Turn-Off Time (Note 7)	t _{OFF}	V _{NO_} = 3V, R _L = 300Ω, C _L = 35pF, Figure 2	T _A = +25°C	6	11	ns
			T _A = T _{MIN} to T _{MAX}		13	
Break-Before-Make Time (Note 7)	t _{BBM}	V _{NO_} = 3V, R _L = 300Ω, C _L = 35pF, Figure 3	T _A = +25°C	8		ns
			T _A = T _{MIN} to T _{MAX}	1		
Charge Injection	Q	V _{GEN} = 2V, R _{GEN} = 0, C _L = 5pF, Figure 4		2		pC
Off-Isolation (Note 8)	V _{ISO}	C _L = 5pF, R _L = 50Ω, Figure 5	f = 10MHz	-57		dB
			f = 1MHz	-80		
Crosstalk (Note 9)	V _{CT}	C _L = 5pF, R _L = 50Ω, Figure 5	f = 10MHz	-52		dB
			f = 1MHz	-78		
NO_ Off-Capacitance	C _{NO_(OFF)}	Figure 6		13		pF
COM Off-Capacitance	C _{COM(OFF)}	Figure 6		52		pF
COM On-Capacitance	C _{COM(ON)}	C _L = 5pF, Figure 6		68		pF
Total Harmonic Distortion	THD	R _L = 600Ω, f = 20Hz to 20kHz		0.018		%
POWER SUPPLY						
Power-Supply Range	V ₊		1.8		5.5	V
Positive Supply Current	I ₊	V ₊ = 5.5V, V _{IH} = V ₊ , V _{IL} = 0		0.001	1.0	μA

ELECTRICAL CHARACTERISTICS—Single +3V Supply

(V₊ = +2.7V to +3.3V, V_{IH} = 2.0V, V_{IL} = 0.4V, T_A = -40°C to +85°C, unless otherwise noted. Typical values are at V₊ = +3V, T_A = +25°C.) (Notes 2, 3)

PARAMETER	SYMBOL	CONDITIONS	MIN	TYP	MAX	UNITS
ANALOG SWITCH						
Analog Signal Range	V _{COM} , V _{NO_}		0		V ₊	V
On-Resistance	R _{ON}	V ₊ = 2.7V, I _{COM} = 10mA, V _{NO_} = 0 to V ₊	T _A = +25°C	4.5	7	Ω
			T _A = T _{MIN} to T _{MAX}		8	
On-Resistance Match Between Channels (Notes 4, 5)	ΔR _{ON}	V ₊ = 2.7V, I _{COM} = 10mA, V _{NO_} = 0 to V ₊	T _A = +25°C	0.1	0.3	Ω
			T _A = T _{MIN} to T _{MAX}		0.4	

Fast, Low-Voltage, 4Ω, 4-Channel CMOS Analog Multiplexer

ELECTRICAL CHARACTERISTICS—Single +3V Supply (continued)

(V+ = +2.7V to +3.3V, V_{IH} = 2.0V, V_{IL} = 0.4V, T_A = -40°C to +85°C, unless otherwise noted. Typical values are at V+ = +3V, T_A = +25°C.) (Notes 2, 3)

PARAMETER	SYMBOL	CONDITIONS		MIN	TYP	MAX	UNITS
On-Resistance Flatness (Note 6)	R _{FLAT(ON)}	V+ = 2.7V, I _{COM} = 10mA, V _{NO-} = 0 to V+	T _A = +25°C	1.2	2.5	3	Ω
			T _A = T _{MIN} to T _{MAX}				
NO ₋ Off-Leakage Current (Note 7)	I _{NO-(OFF)}	V+ = 3.3V; V _{COM} = 1V, 3V; V _{NO-} = 3V, 1V	T _A = +25°C	-0.1	±0.01	+0.1	nA
			T _A = T _{MIN} to T _{MAX}	-0.3		+0.3	
COM Off-Leakage Current (Note 7)	I _{COM(OFF)}	V+ = 3.3V; V _{COM} = 1V, 3V; V _{NO-} = 3V, 1V	T _A = +25°C	-0.1	±0.01	+0.1	nA
			T _A = T _{MIN} to T _{MAX}	-0.65		+0.65	
COM On-Leakage Current (Note 7)	I _{COM(ON)}	V+ = 3.3V; V _{COM} = 1V, 3V; V _{NO-} = 1V, 3V, or unconnected	T _A = +25°C	-0.1	±0.01	+0.1	nA
			T _A = T _{MIN} to T _{MAX}	-0.65		+0.65	
DIGITAL I/O (A₋, EN)							
Input High	V _{IH}			2.0			V
Input Low	V _{IL}					0.4	V
Input Logic Current				-100	5	+100	nA
DYNAMIC							
Turn-On Time (Note 7)	t _{ON}	V _{NO-} = 2V, C _L = 35pF, R _L = 300Ω, Figure 2	T _A = +25°C	16	22	24	ns
			T _A = T _{MIN} to T _{MAX}				
Turn-Off Time (Note 7)	t _{OFF}	V _{NO-} = 2V, C _L = 35pF, R _L = 300Ω, Figure 2	T _A = +25°C	8	14	16	ns
			T _A = T _{MIN} to T _{MAX}				
Break-Before-Make Time (Note 7)	t _{BBM}	V _{NO-} = 2V, C _L = 35pF, R _L = 300Ω, Figure 3	T _A = +25°C	9		1	ns
			T _A = T _{MIN} to T _{MAX}				
Charge Injection	Q	V _{GEN} = 1.5V, R _{GEN} = 0, C _L = 5pF, Figure 4		2			pC
Off-Isolation (Note 8)	V _{ISO}	C _L = 5pF, R _L = 50Ω, Figure 5	f = 10MHz	-57			dB
			f = 1MHz	-80			
Crosstalk (Note 9)	V _{CT}	C _L = 5pF, R _L = 50Ω, Figure 5	f = 10MHz	-52			dB
			f = 1MHz	-78			

Fast, Low-Voltage, 4Ω, 4-Channel CMOS Analog Multiplexer

MAX4634

ELECTRICAL CHARACTERISTICS—Single +3V Supply (continued)

($V_+ = +2.7V$ to $+3.3V$, $V_{IH} = 2.0V$, $V_{IL} = 0.4V$, $T_A = -40^\circ C$ to $+85^\circ C$, unless otherwise noted. Typical values are at $V_+ = +3V$, $T_A = +25^\circ C$.) (Notes 2, 3)

PARAMETER	SYMBOL	CONDITIONS	MIN	TYP	MAX	UNITS
NO_ Off-Capacitance	$C_{NO(OFF)}$	$V_{NO_} = GND$, $f = 1MHz$, Figure 6		13		pF
COM Off-Capacitance	$C_{COM(OFF)}$	$V_{COM} = GND$, $f = 1MHz$, Figure 6		52		pF
COM On-Capacitance	$C_{(ON)}$	$V_{COM} = V_{NO_} = GND$, $f = 1MHz$, Figure 6		68		pF
Total Harmonic Distortion	THD	$R_L = 600\Omega$, $f = 20Hz$ to $20kHz$		0.018		%
POWER SUPPLY						
Positive Supply Current	I_+	$V_+ = 3.3V$, $V_{IH} = V_+$, $V_{IL} = 0$		0.001	1	μA

Note 2: The algebraic convention, where the most negative value is a minimum and the most positive value a maximum, is used in this data sheet.

Note 3: TDFN parts are tested at $+25^\circ C$ and guaranteed by design and correlation over the entire temperature range.

Note 4: $\Delta R_{ON} = R_{ON(MAX)} - R_{ON(MIN)}$.

Note 5: R_{ON} and ΔR_{ON} matching specifications for TDFN-packaged parts are guaranteed by design.

Note 6: Flatness is defined as the difference between the maximum and minimum value of on-resistance as measured over the specified analog signal ranges.

Note 7: Guaranteed by design.

Note 8: Off-isolation = $20\log_{10}(V_{COM} / V_{NO_})$, where V_{COM} = output and $V_{NO_}$ = input to off switch.

Note 9: Between any two switches.

Typical Operating Characteristics

($T_A = +25^\circ C$, unless otherwise noted.)

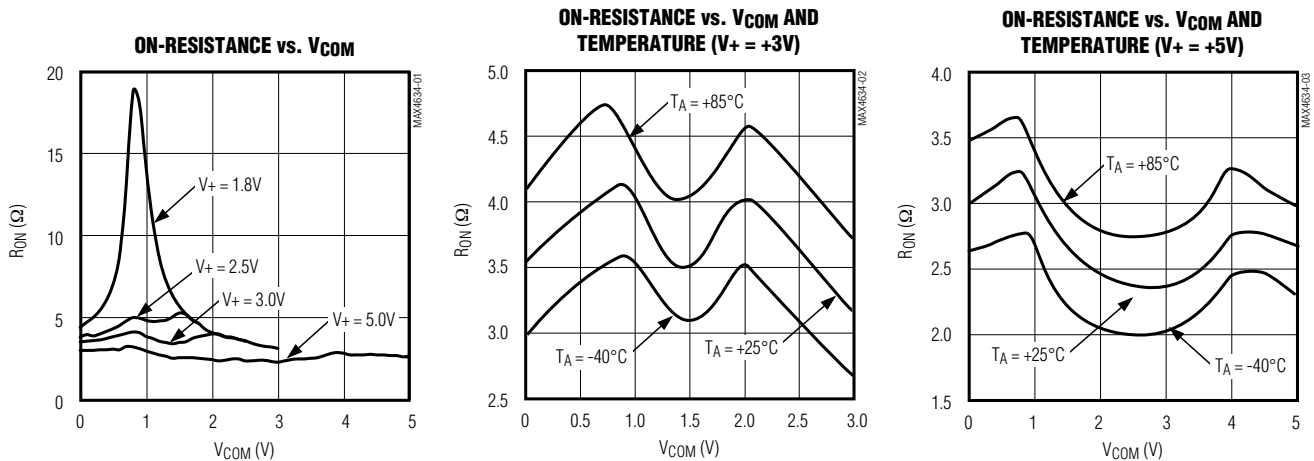

Fast, Low-Voltage, 4Ω, 4-Channel CMOS Analog Multiplexer

Typical Operating Characteristics (continued)

(T_A = +25°C, unless otherwise noted.)

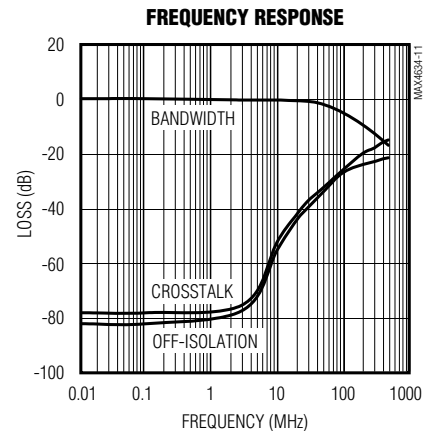
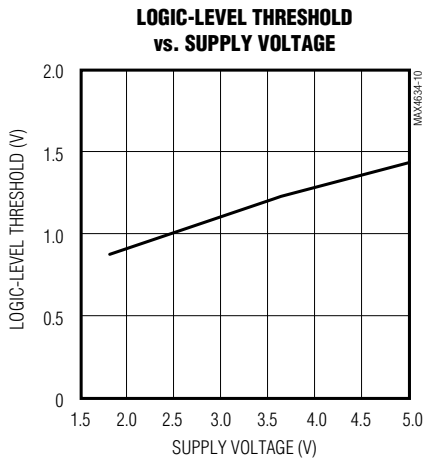
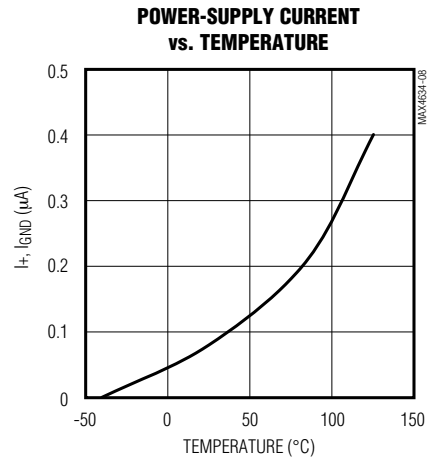
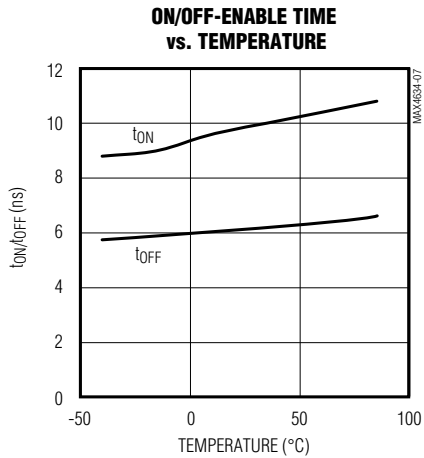
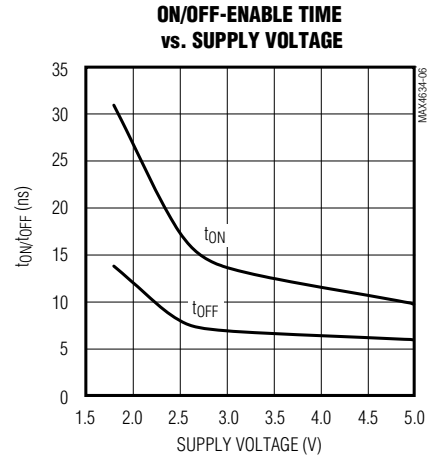
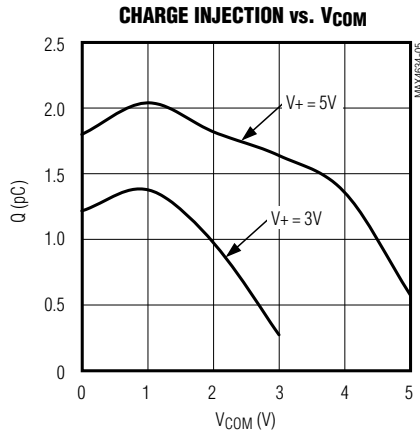
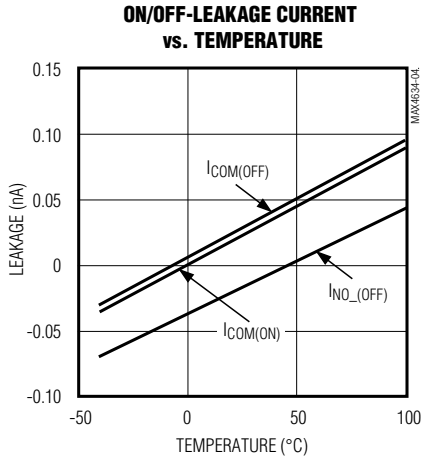

Fast, Low-Voltage, 4Ω, 4-Channel CMOS Analog Multiplexer

MAX4634

Pin Description

PIN	NAME	FUNCTION
1	A0	Address Input. See the <i>Truth Table</i> for details.
2	NO1	Normally Open Switch 1
3	GND	Ground
4	NO3	Normally Open Switch 3
5	EN	Enable Logic Input. See the <i>Truth Table</i> for details.
6	V+	Positive Supply Voltage. Connect to an external power supply. Bypass to GND with a 10μF capacitor placed as close to the pin as possible.
7	NO4	Normally Open Switch 4
8	COM	Analog Switch Common Terminal
9	NO2	Normally Open Switch 2
10	A1	Address Input. See the <i>Truth Table</i> for details.
—	EP	Exposed Pad. Internally connected to GND. Connect to a large PCB ground plane for proper operation. Not intended as an electrical connection point (TDFN package only).

Detailed Description

The MAX4634 is a low-on-resistance, low-voltage analog multiplexer that operates from a +1.8V to +5.5V single supply. CMOS switch construction allows processing of analog signals that are within the supply voltage range (GND to V+).

To disable all switch channels, drive EN low. All four inputs and COM become high impedance during this state. If the disable feature is not needed, connect EN to V+.

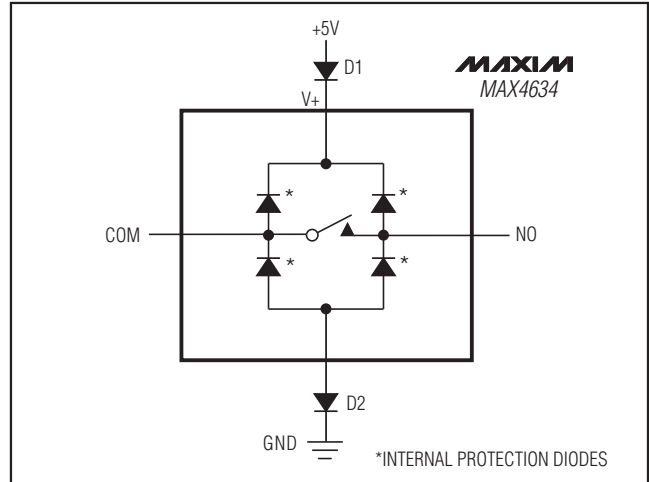

Figure 1. Overvoltage Protection Using External Blocking Diodes

Applications Information

Power-Supply Sequencing and Overvoltage Protection

Proper power-supply sequencing is recommended for all CMOS devices. Always apply V+ before applying analog signals or logic inputs, especially if the analog or logic signals are not current limited. If this sequencing is not possible, and if the analog or logic inputs are not current limited to < 20mA, add a small-signal diode (D1) as shown in Figure 1. If the analog signal can dip below GND, add D2. Adding protection diodes reduces the analog signal range to a diode drop (about 0.7V) below V+ for D1 or to a diode drop above ground for D2. The addition of diodes does not affect leakage. On-resistance increases by a small amount at low supply voltages. Maximum supply voltage (V+) must not exceed 6V.

Protection diodes D1 and D2 also protect against some overvoltage situations. A fault voltage up to the absolute maximum rating at an analog signal input does not damage the device, even if the supply voltage is below the signal voltage.

Fast, Low-Voltage, 4Ω, 4-Channel CMOS Analog Multiplexer

Test Circuits/Timing Diagrams

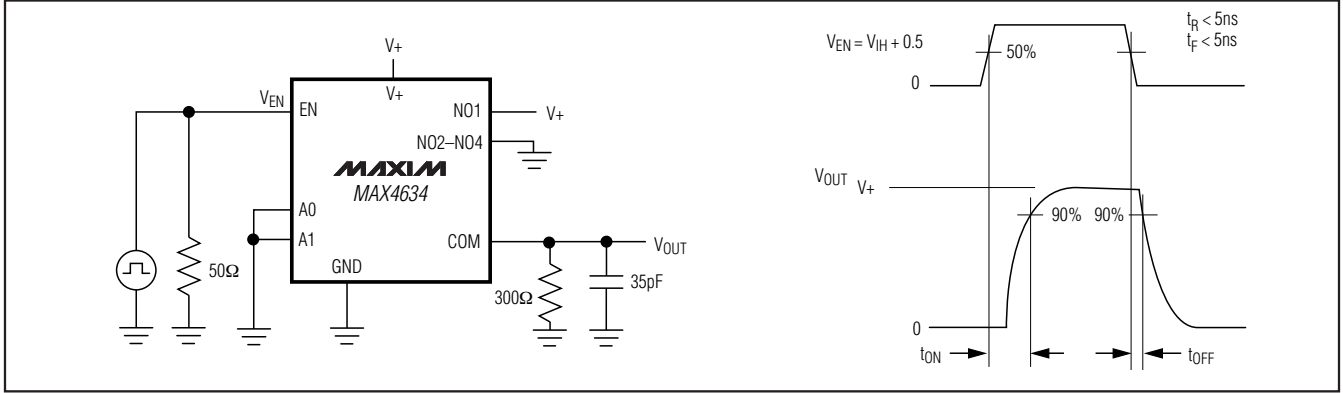

Figure 2. Switching Time

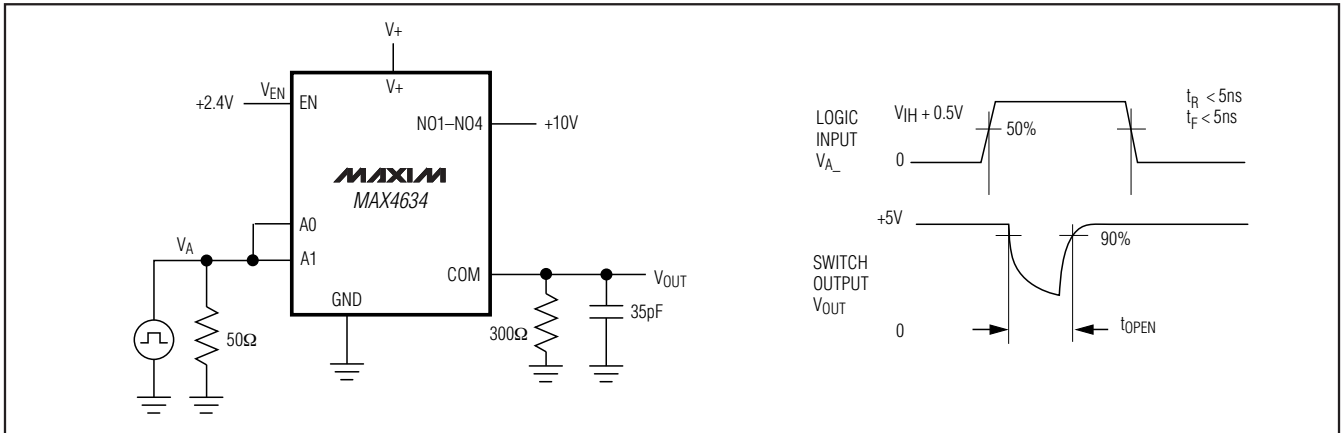

Figure 3. Break-Before-Make Interval

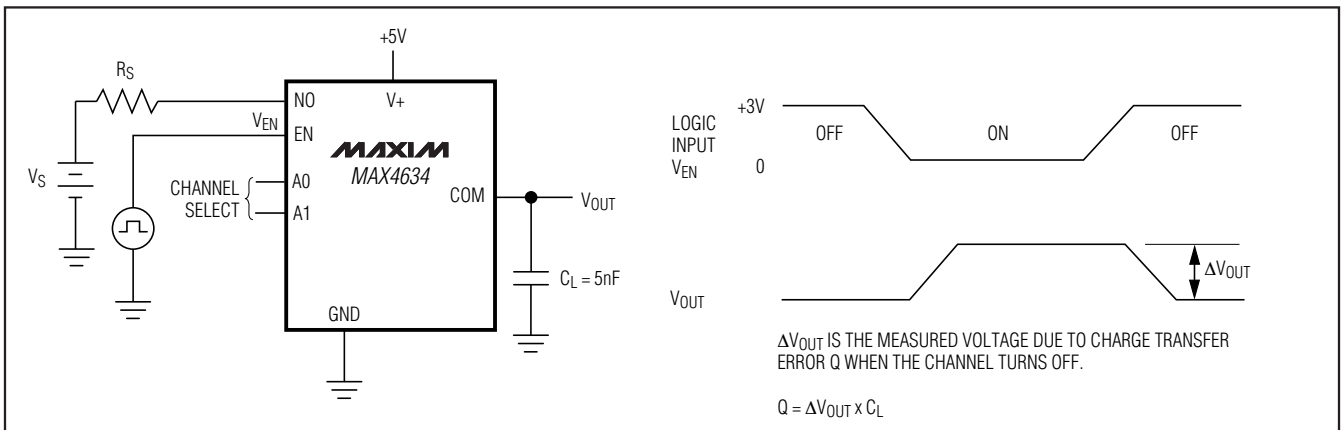

Figure 4. Charge Injection

Fast, Low-Voltage, 4Ω, 4-Channel CMOS Analog Multiplexer

MAX4634

Test Circuits/Timing Diagrams (continued)

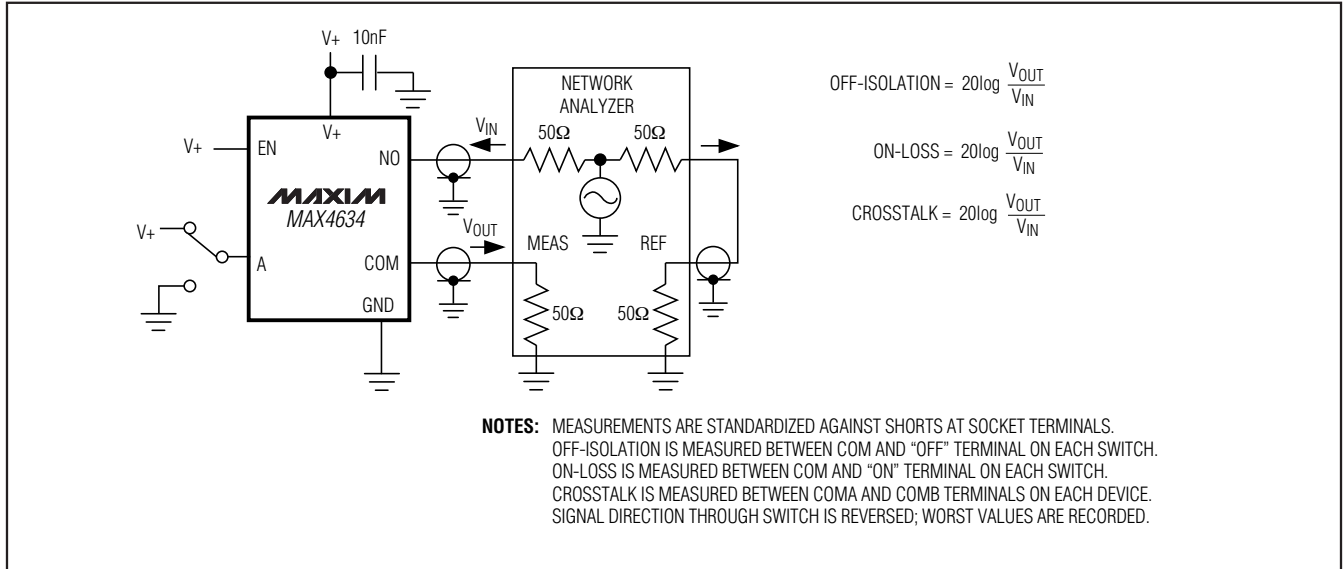

Figure 5. Off-Isolation/On-Channel Bandwidth

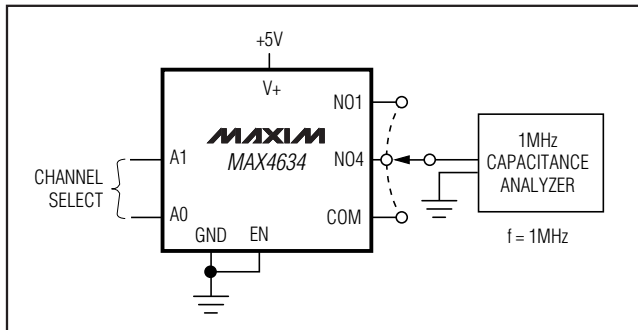

Figure 6. Channel Off/On-Capacitance

Chip Information

PROCESS: CMOS

Package Information

For the latest package outline information and land patterns, go to www.maxim-ic.com/packages.

PACKAGE TYPE	PACKAGE CODE	DOCUMENT NO.
10 μMAX	—	21-0061
10 TDFN	T1033-1	21-0137

Fast, Low-Voltage, 4 Ω , 4-Channel CMOS Analog Multiplexer

Revision History

REVISION NUMBER	REVISION DATE	DESCRIPTION	PAGES CHANGED
0	4/00	Initial release	—
1	2/02	Added QFN package	—
2	5/03	Added QFN packaging information	—
3	2/09	Added TDFN package information (replaced QFN), style edits	1, 7

Maxim cannot assume responsibility for use of any circuitry other than circuitry entirely embodied in a Maxim product. No circuit patent licenses are implied. Maxim reserves the right to change the circuitry and specifications without notice at any time.

10 **Maxim Integrated Products, 120 San Gabriel Drive, Sunnyvale, CA 94086 408-737-7600**

© 2009 Maxim Integrated Products

Maxim is a registered trademark of Maxim Integrated Products, Inc.