

Product Brief

TC358840 Camera Serial Interface Converter Chipset (4K HDMI® to MIPI® CSI-2)

Highlights

- 4K Ultra High Definition (HD) video streams into MIPI® Camera Serial Interface (CSI-2)
- Enables application processors with dual MIPI CSI-2 interfaces to accept up to 4K resolution HDMI® sources as an input stream.
- Ideal for mobile and CE solutions that require 4K HDMI video source as input.
- Support for 3D formats and compatible protocols with the HDMI 1.4b standard
- Support for up to:
 - 4096 x 2160 @ 24bpp video resolution at refresh rates of 24 fps
 - 3840 x 2160 @ 24bpp video resolution at refresh rates of 30 fps
- Enables YCbCr to RGB and YCbCr to RGB color format conversion.
- I²S and SLIMbus® audio support
- Applications include 4K Ultra HD resolution TVs, monitors, set-top boxes, and digital media adapters.

Description

The Toshiba TC358840 High Definition Multimedia Interface (HDMI®) to MIPI® Camera Serial Interface Type 2 (CSI-2) converter chipset supports 4K video resolution for next-generation Ultra High Definition video applications. The TC358840 enables a host processor with a MIPI CSI-2 dual link interface to accept 4K HDMI video and audio streams and process them as an incoming data source. Application processors can generate different types of video data for internal displays, external displays, as well as analog TV and HDMI TV; but some application processors have limitations in handling video data as an input source. A common input interface in application processors for video streams is MIPI CSI-2, which is a high-speed serial interface to an embedded camera. The Toshiba TC358840 bridge chips enable a 4K HDMI video stream to be converted in a format that can be processed by the application processor as a MIPI CSI-2 video stream. HDMI audio stream is also supported and can be transmitted over I²S or over a MIPI SLIMbus® (Serial Low-power Inter-chip Media Bus).

The Toshiba TC358840 is a follow on part to the Toshiba TC358743 adding a 297 MHz HDMI Receiver (Rx) and a dual CSI interface to support next-generation 4K Ultra HD video format.

The maximum resolution supported is 4096 x 2160 @ 24 bpp at a refresh rate of 24 fps, limited by maximum 297 MHz HDMI bandwidth. The bridge supports common 3D video formats and protocols compatible with the HDMI 1.4b standard. The TC358840 supports a dual MIPI CSI-2 interface to the Host with configurable 1 thru 8 data lanes at speeds of up to 1.0 Gbps per lane.

The Toshiba TC358840XBG comes in an 80-pin small package size of 7 mm x 7 mm, 0.65 mm ball pitch, and 1.0 mm maximum height designed for non-HDI board. It is designed with clock and power management circuitry to support low-power states.

Features

HDMI-RX Interface

- HDMI 1.4b
 - Video format support
 - Up to 4096 x 2160 (4Kx2K) @ 24 fps RGB or YCbCr444: 24-bpp (bit-per pixel)
 - Up to 3840 x 2160, @ 30 fps, RGB or YCbCr444: 24-bpp

TC358840 Camera Serial Interface Converter Chipset (4K HDMI to MIPI CSI-2) Block Diagram

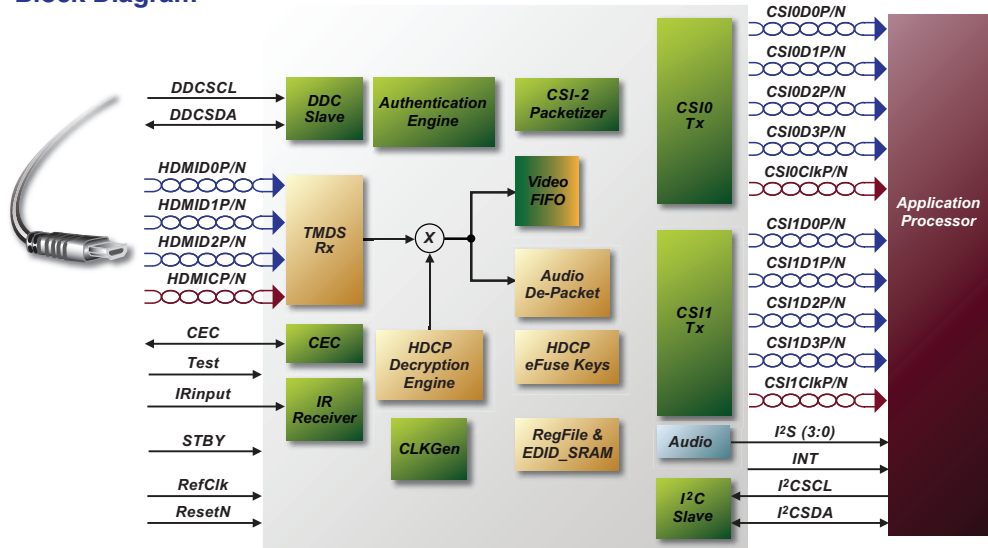

Regional Sales Offices

NORTHWEST

San Jose, CA
TEL: (408) 526-2400
FAX: (408) 526-2410

SOUTHWEST

Irvine, CA
TEL: (949) 462-7700
FAX: (949) 462-2200
El Paso, TX
TEL: 915-771-8156
FAX: 915-771-8178

MIDWEST

Wixom, MI
TEL: (248) 347-2607
FAX: (248) 347-2602
Buffalo Grove, IL
TEL: (847) 484-2400
FAX: (847) 541-7287

NORTHEAST

Marlboro, MA
TEL: (508) 481-0034
FAX: (508) 481-8828
Parsippany, NJ
TEL: (973) 541-4715
FAX: (973) 541-4716

SOUTHEAST

Duluth, GA
TEL: (770) 931-3363
FAX: (770) 931-7602

www.Toshiba.com/taec

TOSHIBA
Leading Innovation >>>

- Color format conversion support
 - 4:2:2 to 4:4:4
 - 4:4:4 to 4:2:2
 - RGB888 to YCbCr (4:4:4/4:2:2)
 - YCbCr (4:4:4/4:2:2) to RGB888/666
 - Maximum HDMI clock speed of 297 MHz
 - Audio support
 - Internal audio PLL to track N/CTS value transmitted by the ACR packet
 - 3D support
 - HDCP1.4 support
 - EDID support

CSI-2 TX Interface

- MIPI CSI-2 compliant (version 1.01 revision 0.04 –2 April 2009)
- Dual links CSI-2, CSI0 and CSI1, each link supports 4 data lanes @ 1Gbps/data lane
 - CSI0 carries the left half data of HDMI Rx video stream and CSI1 carries the right half of HDMI Rx video stream
 - CSI0 can be assigned/programmed to either CSI-2 Tx
 - Supports video data formats
- RGB888, YCbCr444, YCbCr422 24-bit and YCbCr422 16-bit

I²C Slave Mode Interface

- Support for normal (100 KHz), fast mode (400 KHz) and ultrafast mode (2MHz)
- Used by an external Master to configure all TC358840 internal registers
- Supports two I²C slave addresses (7'h0F & 7'h1F) selected through boot-strap pin (INT)

Audio Output Interface

Any of the four audio interfaces are available: I²S, TDM, S/P-DIF or SLIMbus (pins are multiplexed)

I²S Audio Interface

- Up to 4 data lanes for 8-channel data

- Supports Master Clock mode only
- Supports 16, 18, 20 or 24-bit data
- Supports left or right-justify with MSB first
- Supports 32 bit-wide time-slot only
- Output audio over sampling clock (256 x fs)
- Supports IEC 60958 & IEC 61937 (HBR support) digital audio formats

TDM (Time Division Multiplexed) Audio Interface

- Fixed to 8 channels
- Supports Master Clock mode only
- Supports 16, 18, 20 or 24-bit PCM audio data word
- Supports 32 bit-wide time slot only
- Output Audio Oversampling clock (256 x fs)

S/P-DIF Audio Interface

- Supports 2-channels

MIPI SLIMbus Audio Interface

- Up to 8-channel data (2, 4, 6 or 8)
- Supports Active Framer (Host) mode as well as Active Framer outside the chip
- Supports isochronous, pushed and pulled protocols
- Supports up to 28.8MHz root clock frequency (in Active Framer mode)

Infrared (IR)

- Supports NEC Infrared (IR) protocol

Power supply inputs

- Core: 1.1V and MIPI D-PHY: 1.2V
- I/O: 1.8V - 3.3V
- HDMI, audio and analog PLL: 3.3V

Package

- TC358840XBG is available with and without HDCP keys
- TC358840XBG package for non-HDI board:
 - 80-pin, 7.0 x 7.0 mm, 0.65 mm ball pitch, 1.0 mm maximum height

MIPI and SLIMbus are registered trademarks of MIPI Alliance, Inc. in the U.S. and other jurisdictions.

HDMI is a registered trademark of HDMI Licensing, LLC in the U.S. and other jurisdictions

• The information contained herein is subject to change without notice.

• The information contained herein is presented only as a guide for the applications of our products. No responsibility is assumed by TOSHIBA for any infringements of patents or other rights of the third parties which may result from its use. No license is granted by implication or otherwise under any patent or patent rights of TOSHIBA or others.

• TOSHIBA is continually working to improve the quality and reliability of its products. Nevertheless, semiconductor devices in general can malfunction or fail due to their inherent electrical sensitivity and vulnerability to physical stress. It is the responsibility of the buyer, when utilizing TOSHIBA products, to comply with the standards of safety in making a safe design for the entire system, and to avoid situation in which a malfunction or failure of such TOSHIBA products could cause loss of human life, bodily injury or damage to property. In developing your designs, please ensure that TOSHIBA products are used within specified operating ranges as set forth in the most recent TOSHIBA products specifications. Also, please keep in mind the precautions and conditions set forth in the "Handling Guide for Semiconductor Devices," or "TOSHIBA Semiconductor Reliability Handbook" etc.

• The Toshiba products listed in this document are intended for usage in general electronics applications (computer, personal equipment, office equipment, measuring equipment, industrial robotics, domestic appliances, etc.). These Toshiba products are neither intended nor warranted for usage in equipment that requires extraordinarily high quality and/or reliability or a malfunction or failure of which may cause loss of human life or bodily injury ("Unintended Usage"). Unintended Usage include atomic energy control instruments, airplane or spaceship instruments, transportation instruments, traffic signal instruments, combustion control instruments, medical instruments, all types of safety devices, etc. Unintended usage of Toshiba products listed in this document shall be made at the customer's own risk.

• The products described in this document may include products subject to foreign exchange and foreign trade laws.

• The products contained herein may also be controlled under the U.S. Export Administration Regulations and/or subject to the approval of the U.S. Department of Commerce or U.S. Department of State prior to export. Any export or re-export, directly or indirectly in contravention of any of the applicable export laws and regulations, is hereby prohibited.

TC358840 Camera Serial Interface Converter Chipset (4K HDMI® to MIPI® CSI-2)

All trademarks are of their respective manufacturer and may be registered in certain jurisdictions.

© Copyright 2/2014 TAEC