

PPC440EP

Data Sheet

PowerPC 440EP Embedded Processor

Features

- PowerPC® 440 processor core operating up to 667MHz with 32KB I-cache and D-cache with parity checking.
- Selectable processor:bus clock ratios of N:1, N:2.
- Floating Point Unit with single- and double-precision and single-cycle throughput.
- Dual bridged Processor Local Buses (PLBs) with 64- and 128-bit widths.
- Double Data Rate (DDR) Synchronous DRAM (SDRAM) interface operating up to 133MHz with ECC.
- DMA support for external peripherals, internal UART and memory.
- PCI V2.2 interface (3.3V only). Thirty-two bits at up to 66MHz.
- Programmable interrupt controller supports interrupts from a variety of sources.
- Programmable General Purpose Timers (GPT).
- Two Ethernet 10/100Mbps half- or full-duplex interfaces. Operational modes supported are MII, RMII, and SMII with packet reject.
- Up to four serial ports (16550 compatible UART).
- Two USB ports. One USB 1.1 Host interface with on-chip PHY. One USB 2.0 Device interface, with dedicated DMA, configured as a 1.1 on-chip PHY or a 2.0 UTMI.
- External peripheral bus (16-bit data) for up to six devices with external mastering.
- Two IIC interfaces (one with boot parameter read capability).
- NAND Flash interface.
- SPI interface.
- General Purpose I/O (GPIO) interface.
- JTAG interface for board level testing.
- Boot from PCI memory, NOR Flash on the external peripheral bus, or NAND Flash on the NAND Flash interface.
- Available in RoHS compliant lead-free package.

Description

Designed specifically to address high-end embedded applications, the PowerPC 440EP (PPC440EP) provides a high-performance, low- power solution that interfaces to a wide range of peripherals and incorporates on-chip power management features.

This chip contains a high-performance RISC processor, a floating point unit, DDR SDRAM controller, PCI bus interface, control for external ROM and peripherals, DMA with scatter-gather support, Ethernet ports, serial ports, IIC interfaces, SPI interface, USB ports, NAND Flash interface, and general purpose I/O.

Technology: CMOS Cu-11, 0.13µm.

Package: 35mm, 456-ball standard plastic ball grid array (E-PBGA), with and without lead (RoHS compliant).

Typical power (measured): Less than 3W at 533MHz, 2.5W at 400MHz.

Supply voltages required: 3.3V, 2.5V, 1.5V.

Contents

Ordering and PVR Information 5

Block Diagram 6

Address Maps 7

PPC440EP Features 10

PowerPC 440 Processor Core 10

Floating Point Unit (FPU) 10

Internal Buses 11

PCI Interface 12

DDR SDRAM Memory Controller 12

External Peripheral Bus Controller (EBC) 13

Ethernet Controller Interface 13

DMA to PLB3 Controller 13

DMA to PLB4 Controller 14

Serial Ports (UART) 14

IIC Bus Interface 14

Serial Peripheral Interface (SPI/SCP) 15

Universal Serial Bus (USB) 15

NAND Flash Controller 15

General Purpose Timers (GPT) 16

General Purpose IO (GPIO) Controller 16

Universal Interrupt Controller (UIC) 16

JTAG 16

Package Diagram 17

Assembly Recommendations 18

Signal Lists 19

Signal Descriptions 50

Device Characteristics 61

Clocking Specifications 68

I/O Specifications 70

DDR1 SDRAM I/O Specifications 77

Boot Configuration 86

Revision Log 87

Data Sheet**Figures**

Figure 1. Order Part Number Key	5
Figure 2. PPC440EP Functional Block Diagram	6
Figure 3. 35mm, 456-Ball E-PBGA	17
Figure 4. Overshoot Waveform	63
Figure 5. Timing Waveform	69
Figure 6. Input Setup and Hold Waveform	71
Figure 7. Output Delay and Float Timing Waveform	71
Figure 8. DDR SDRAM Simulation Signal Termination Model	77
Figure 9. DDR SDRAM Write Cycle Timing	79
Figure 10. DDR SDRAM MemClkOut0 and Read Clock Delay	81
Figure 11. DDR SDRAM Read Data Path	82
Figure 12. DDR SDRAM Read Cycle Timing—Example 1	83
Figure 13. DDR SDRAM Read Cycle Timing—Example 2	84
Figure 14. DDR SDRAM Read Cycle Timing—Example 3	85

Tables

Table 1. System Memory Address Map 7

Table 2. DCR Address Map (4KB of Device Configuration Registers) 9

Table 3. Recommended Reflow Soldering Profile 18

Table 4. JEDEC Moisture Sensitivity Level and Ball Composition 18

Table 5. Signals Listed Alphabetically 19

Table 6. Signals Listed by Ball Assignment 43

Table 7. Pin Summary 50

Table 8. Signal Functional Description 52

Table 9. Absolute Maximum Ratings 61

Table 10. Recommended DC Operating Conditions 61

Table 11. Overshoot and Undershoot 63

Table 12. Typical DC Power Supply Requirements 65

Table 13. V_{DD} Supply Power Dissipation 65

Table 14. DC Power Supply Current Loads 66

Table 15. Package Thermal Specifications 67

Table 16. Clocking Specifications 68

Table 17. Peripheral Interface Clock Timings 70

Table 18. I/O Specifications—PCI, USB, UART, IIC, SPI, Ethernet, System and Debug Interfaces 72

Table 19. I/O Specifications—EBC, EBMI, DMA and NAND Flash Interfaces 75

Table 20. Input Capacitance 75

Table 21. DDR SDRAM Output Driver Specifications 78

Table 22. I/O Timing—DDR SDRAM T_{DS} 80

Table 23. I/O Timing—DDR SDRAM T_{SK} , T_{SA} , and T_{HA} 80

Table 24. I/O Timing—DDR SDRAM T_{SD} and T_{HD} 80

Table 25. I/O Timing—DDR SDRAM T_{SIN} and T_{DIN} 82

Table 26. Strapping Pin Assignments 86

Data Sheet

Ordering and PVR Information

For information on the availability of the following parts, contact your local AppliedMicro sales office.

Product Name	Order Part Number (see Notes:)	Package	Revision Level	PVR Value	JTAG ID
PPC440EP	PPC440EP-3pbfffCx	35mm, 456 ball, E-PBGA	C	0x422218D4	0x2A950049

Notes:

1. p = Module Package type
 B = standard (E-PBGA) and contains lead.
 J = standard (E-PBGA) and is lead-free (RoHS compliant)
2. b = Chip revision level
 C = Revision level C (2.1)
3. fff = Processor frequency
 333 = 333MHz
 400 = 400MHz
 533 = 533MHz
 667 = 667MHz
4. C = Case temperature range:
 -40°C to + 90°C for 333MHz and 400 MHz parts
 -40°C to +100°C for 533MHz parts
 -40°C to +85°C for 667MHz parts
5. x = Shipping package type
 Z = tape-and-reel
 Blank = tray

Each part number contains a revision code. This is the die mask revision number and is included in the part number for identification purposes only.

The PVR (Processor Version Register) and the JTAG ID register are software accessible (read-only) and contain information that uniquely identifies the part. Refer to the *PPC440EP User's Manual* for details on accessing these registers.

Figure 1. Order Part Number Key

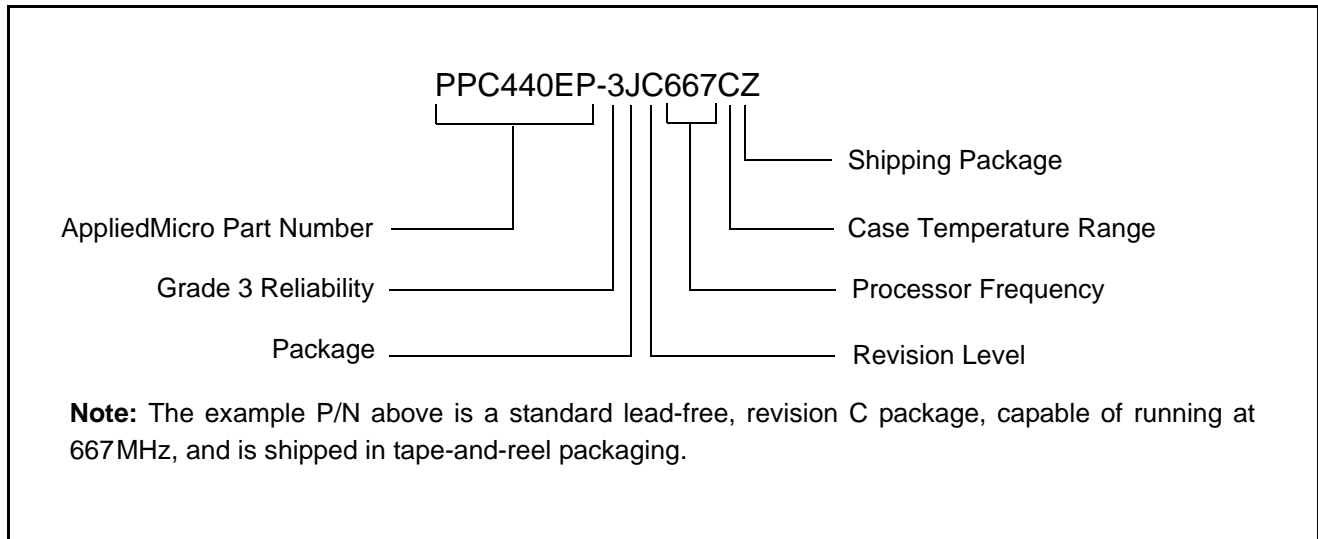

Block Diagram

Figure 2. PPC440EP Functional Block Diagram

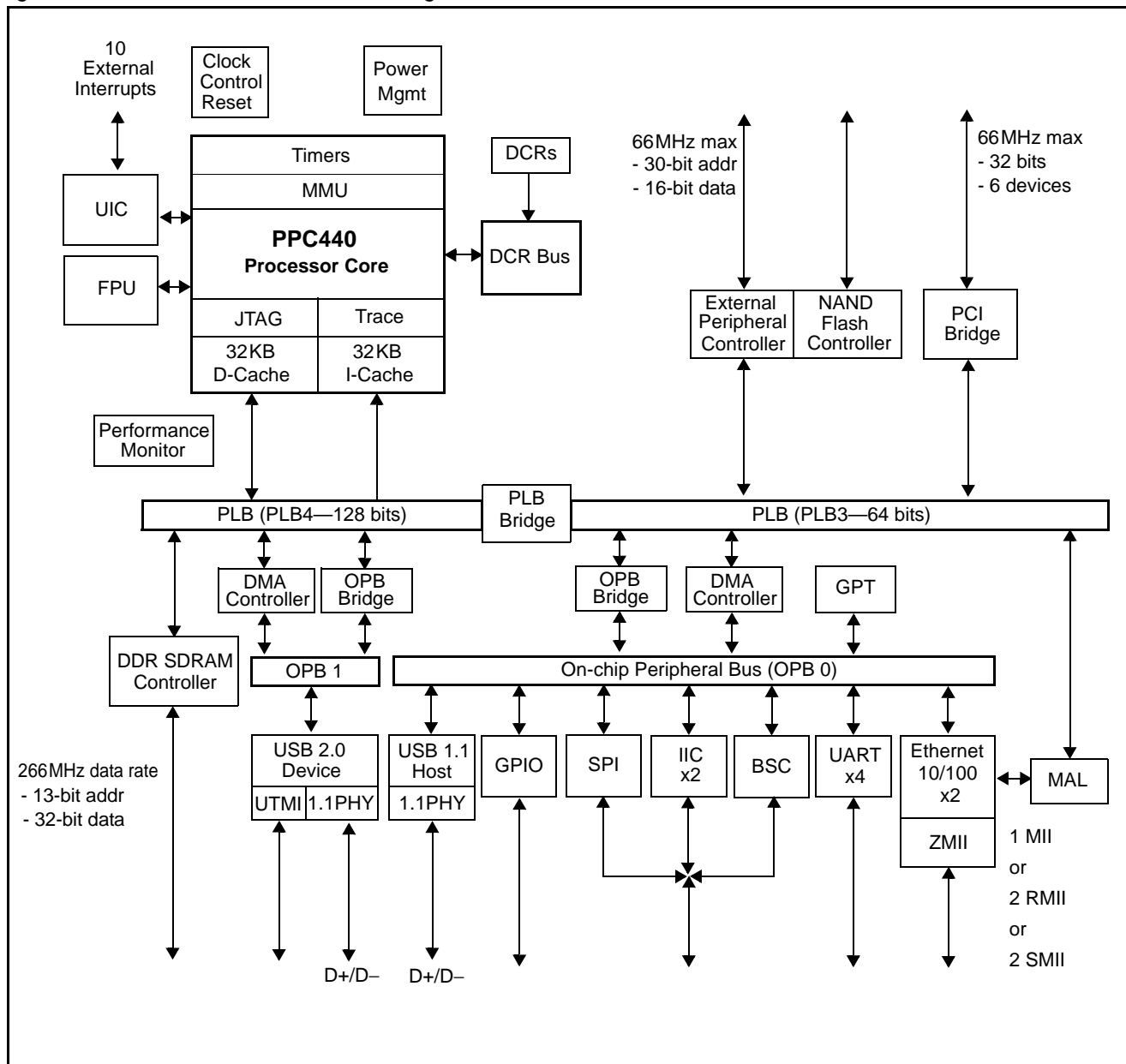

The PPC440EP is a system on a chip (SOC).

Data Sheet**Address Maps**

The PPC440EP incorporates two address maps. The first is a fixed processor System Memory Address Map. This address map defines the possible contents of various address regions which the processor can access. The second is the DCR Address Map for Device Configuration Registers (DCRs). The DCRs are accessed by software running on the PPC440EP processor through the use of **mtdcr** and **mfdcr** instructions.

Table 1. System Memory Address Map (Sheet 1 of 2)

Function	Sub Function	Start Address	End Address	Size
Local Memory ¹	DDR SDRAM	0 0000 0000	0 3FFF FFFF	1GB
	Reserved	0 4000 0000	0 4FFF FFFF	
USB 2.0 Device Bus	OPB Arbiter for USB (OPB 1)	0 5000 0000	0 5000 003F	64B
	Reserved	0 5000 0040	0 5000 00FF	
	USB 2.0 Device	0 5000 0100	0 5000 017F	128B
	Reserved	0 5000 0180	0 7FFF FFFF	
EBC	EBC	0 8000 0000	0 9FFF FFFF	512MB
PCI	PCI Memory	0 A000 0000	0 DFFF FFFF	1GB
	Reserved	0 E000 0000	0 E7FF FFFF	
	PCI I/O	0 E800 0000	0 E800 FFFF	64KB
	Reserved	0 E801 0000	0 E87F FFFF	
	PCI I/O	0 E880 0000	0 EBFF FFFF	56MB
	Reserved	0 EC00 0000	0 EEBF FFFF	
	Configuration Registers	0 EEC0 0000	0 EEC0 0007	8B
	Reserved	0 EEC0 0008	0 EECF FFFF	
	PCI Interrupt Ack / Special Cycle	0 EED0 0000	0 EED0 0003	4B
	Reserved	0 EED0 0004	0 EF3F FFFF	
	Local Configuration Registers	0 EF40 0000	0 EF40 003F	64B
	Reserved	0 EF40 0040	0 EF4F FFFF	

Table 1. System Memory Address Map (Sheet 2 of 2)

Function	Sub Function	Start Address	End Address	Size
Internal Peripherals	Reserved	0 EF50 0000	0 EF5F FFFF	
	General Purpose Timer	0 EF60 0000	0 EF60 00FF	256B
	Reserved	0 EF60 0100	0 EF60 02FF	
	UART0	0 EF60 0300	0 EF60 0307	8B
	Reserved	0 EF60 0308	0 EF60 03FF	
	UART1	0 EF60 0400	0 EF60 0407	8B
	Reserved	0 EF60 0408	0 EF60 04FF	
	UART2	0 EF60 0500	0 EF60 0507	8B
	Reserved	0 EF60 0508	0 EF60 05FF	
	UART3	0 EF60 0600	0 EF60 0607	8B
	Reserved	0 EF60 0608	0 EF60 06FF	
	IIC0	0 EF60 0700	0 EF60 071F	32B
	Reserved	0 EF60 0720	0 EF60 07FF	
	IIC1	0 EF60 0800	0 EF60 081F	32B
	Reserved	0 EF60 0820	0 EF60 08FF	
	SPI	0 EF60 0900	0 EF60 0906	6B
	Reserved	0 EF60 0907	0 EF60 09FF	
	OPB Arbiter (OPB 0)	0 EF60 0A00	0 EF60 0A3F	64B
	Reserved	0 EF60 0A40	0 EF60 0AFF	
	GPIO0 Controller	0 EF60 0B00	0 EF60 0B7F	128B
	Reserved	0 EF60 0B80	0 EF60 0BFF	
	GPIO1 Controller	0 EF60 0C00	0 EF60 0C7F	128B
	Reserved	0 EF60 0C80	0 EF60 0CFF	
	Ethernet PHY ZMII	0 EF60 0D00	0 EF60 0D0F	16B
	Reserved	0 EF60 0D10	0 EF60 0DFF	
	Ethernet 0 Controller	0 EF60 0E00	0 EF60 0EFF	256B
	Ethernet 1 Controller	0 EF60 0F00	0 EF60 0FFF	256B
	USB 1.1 Host	0 EF60 1000	0 EF60 107F	128B
Reserved	0 EF60 1080	0 EFFF FFFF		
EBC		0 F000 0000	0 FFDF FFFF	254MB
Boot space (EBC Bank 0 and PCI)		0 FFE0 0000	0 FFFF FFFF	2MB

Notes:

1. DDR SDRAM can be located anywhere in the Local Memory area of the memory map.
2. EBC and PCI are relocatable, but this map reflects the suggested configuration.

Data Sheet

Table 2. DCR Address Map (4KB of Device Configuration Registers)

Function	Start Address	End Address	Size
Total DCR Address Space¹	000	3FF	1KW (4KB) ¹
By function:			
Reserved	000	00B	12W
Clocking Power On Reset (CPR)	00C	00D	2W
System DCRs (SDR)	00E	00F	2W
Memory Controller (SDRAM)	010	011	2W
External Bus Controller (EBC)	012	013	2W
Reserved	014	015	2W
PLB 128 Performance Monitor (PPM)	016	017	2W
Reserved	018	01F	8W
PLB 128 to PLB 64 Bridge Out	020	02F	16W
PLB 64 to PLB 128 Bridge In	030	03F	16W
Reserved	040	06F	64W
PLB 64 Arbiter	070	07F	16W
PLB 128 Arbiter	080	08F	16W
PLB 64 to OPB Bridge Out	090	09F	16W
Reserved	0A0	0A7	8W
OPB to PLB 64 Bridge In	0A8	0AF	8W
Power Management	0B0	0B7	8W
Reserved	0B8	0BF	8W
Interrupt Controller 0	0C0	0CF	16W
Interrupt Controller 1	0D0	0DF	16W
Reserved	0E0	0FF	32W
DMA to PLB 64 Controller	100	13F	64W
Reserved	140	17F	64W
Ethernet MAL	180	1FF	128W
PLB 128 to OPB Bridge	200	20F	16W
Reserved	210	2FF	512W
DMA to PLB 128 Controller	300	33F	64W
Reserved	340	3FF	512W

Notes:

1. DCR address space is addressable with up to 10 bits (1024 or 1K unique addresses). Each unique address represents a single 32-bit (word) register. One kiloword (1024W) equals 4KB (4096 B).

PPC440EP Features

The following sections provide information on the features of the chip.

PowerPC 440 Processor Core

The PowerPC 440 processor core is designed for high-end applications: RAID controllers, SAN, iSCSI, routers, switches, printers, set-top boxes, etc. It is the first processor core to implement the new Book E PowerPC embedded architecture and the first to use the 128-bit version of IBM's on-chip CoreConnect Bus Architecture.

Features include:

- Up to 667MHz operation
- PowerPC Book E architecture
- 32KB I-cache, 32KB D-cache
 - UTLB Word Wide parity on data and tag address parity with exception force
- Three logical regions in D-cache: locked, transient, normal
- D-cache full line flush capability
- 41-bit virtual address, 36-bit (64GB) physical address
- Superscalar, out-of-order execution
- 7-stage pipeline
- 3 execution pipelines
- Dynamic branch prediction
- Memory management unit
 - 64-entry, full associative, unified TLB with optional parity
 - Separate instruction and data micro-TLBs
 - Storage attributes for write-through, cache-inhibited, guarded, and big or little endian
- Debug facilities
 - Multiple instruction and data range breakpoints
 - Data value compare
 - Single step, branch, and trap events
 - Non-invasive real-time trace interface
- 24 DSP instructions
 - Single cycle multiply and multiply-accumulate
 - 32 x 32 integer multiply
 - 16 x 16 -> 32-bit MAC

Floating Point Unit (FPU)

Features include:

- Five stages with 2 MFlops/MHz
- Hardware support for IEEE 754
- Single- and double-precision
- Single-cycle throughput on most instructions
- Thirty-two 64-bit floating point registers

Data Sheet

Internal Buses

The PowerPC 440EP features five standard on-chip buses: two Processor Local Buses (PLBs), two On-Chip Peripheral Buses (OPBs), and the Device Control Register Bus (DCR). The high performance, high bandwidth cores such as the PowerPC 440 processor core, the DDR SDRAM memory controller, and the PCI bridge connect to the PLBs. The primary OPB hosts lower data rate peripherals. The secondary OPB is dedicated to USB 2.0 and DMA. The daisy-chained DCR provides a lower bandwidth path for passing status and control information between the processor core and the other on-chip cores.

Features include:

- PLB4
 - 128-bit implementation of the PLB architecture
 - Separate and simultaneous read and write data paths
 - 36-bit address
 - Simultaneous control, address, and data phases
 - Four levels of pipelining
 - Byte-enable capability supporting unaligned transfers
 - 32- and 64-byte burst transfers
 - 133MHz, maximum 4.25GB/s (simultaneous read and write)
 - Processor:bus clock ratios of N:1 and N:2
- PLB3
 - 64-bit implementation of the PLB architecture
 - 32-bit address
 - 133MHz (1:1 ratio with PLB 128), maximum 1.1 GB/s (no simultaneous read and write)
- OPB (2)
 - 32-bit data path
 - 32-bit address
 - 66.66MHz
- DCR
 - 32-bit data path
 - 10-bit address

PCI Interface

The PCI interface allows connection of PCI devices to the PowerPC processor and local memory. This interface is designed to Version 2.2 of the PCI Specification and supports 32-bit PCI devices.

Reference Specifications:

- PowerPC CoreConnect Bus (PLB) Specification Version 3.1
- PCI Specification Version 2.2
- PCI Bus Power Management Interface Specification Version 1.1

Features include:

- PCI 2.2
 - Frequency to 66MHz
 - 32-bit bus
- PCI Host Bus Bridge or an Adapter Device's PCI interface
- Internal PCI arbitration function, supporting up to six external devices, that can be disabled for use with an external arbiter
- Support for Message Signaled Interrupts
- Simple message passing capability
- Asynchronous to the PLB
- PCI Power Management 1.1
- PCI register set addressable both from on-chip processor and PCI device sides
- Ability to boot from PCI bus memory
- Error tracking/status
- Supports initiation of transfer to the following address spaces:
 - Single beat I/O reads and writes
 - Single beat and burst memory reads and writes
 - Single beat configuration reads and writes (type 0 and type 1)
 - Single beat special cycles

DDR SDRAM Memory Controller

The Double Data Rate (DDR) SDRAM memory controller supports industry standard discrete devices. Up to four 256MB logical banks are supported in limited configurations. Global memory timings, address and bank sizes, and memory addressing modes are programmable.

Features include:

- Registered and non-registered industry standard discrete devices
- 32-bit memory interface with optional 8-bit ECC (SEC/DED)
- Sustainable 1.1 GB/s peak bandwidth at 133MHz
- SSTL_2 logic
- 1 to 4 chip selects
- CAS latencies of 2, 2.5 and 3 supported
- DDR200/266 support
- Page mode accesses (up to eight open pages) with configurable paging policy
- Programmable address mapping and timing
- Hardware and software initiated self-refresh
- Power management (self-refresh, suspend, sleep)

Data Sheet

External Peripheral Bus Controller (EBC)

Features include:

- Up to six ROM, EPROM, SRAM, Flash memory, and slave peripheral I/O banks supported
- Up to 66.66MHz operation
- Burst and non-burst devices
- 16-bit byte-addressable data bus
- 30-bit address
- Peripheral Device pacing with external “Ready”
- Latch data on Ready, synchronous or asynchronous
- Programmable access timing per device
 - 256 Wait States for non-burst
 - 32 Burst Wait States for first access and up to 8 Wait States for subsequent accesses
 - Programmable C_{Son}, C_{SoFF} relative to address
 - Programmable O_{Eon}, W_{Eon}, W_{Eoff} (1 to 4 clock cycles) relative to CS
- Programmable address mapping
- External DMA Slave Support
- External master interface
 - Write posting from external master
 - Read prefetching on PLB for external master reads
 - Bursting capable from external master
 - Allows external master access to all non-EBC PLB slaves
 - External master can control EBC slaves for own access and control

Ethernet Controller Interface

Ethernet support provided by the PPC440EP interfaces to the physical layer but the PHY is not included on the chip:

- One to two 10/100 interfaces running in full- and half-duplex modes
 - One full Media Independent Interface (MII) with 4-bit parallel data transfer
 - Two Reduced Media Independent Interfaces (RMII) with 2-bit parallel data transfer
 - Two Serial Media Independent Interfaces (SMII)
 - Packet reject support

DMA to PLB3 Controller

This DMA controller provides a DMA interface between the OPB and the 64-bit PLB.

Features include:

- Supports the following transfers:
 - Memory-to-memory transfers
 - Buffered peripheral to memory transfers
 - Buffered memory to peripheral transfers
- Four channels
- Scatter/Gather capability for programming multiple DMA operations
- 32-byte buffer
- 8-, 16-, 32-bit peripheral support (OPB and external)
- 32-bit addressing
- Address increment or decrement
- Supports internal and external peripherals
- Support for memory mapped peripherals
- Support for peripherals running on slower frequency buses

DMA to PLB4 Controller

This DMA controller provides a DMA interface dedicated to the USB 2.0 device ports and the 128-bit PLB.

Features include:

- 4 independent channels supporting internal USB 2.0 Device endpoints 1 and 2
- Support for memory-to-memory, peripheral-to-memory, and memory-to-peripheral transfers
- Scatter/gather capability
- 128-byte buffer with programmable thresholds

Serial Ports (UART)

Features include:

- Up to four ports in the following combinations:
 - One 8-pin
 - Two 4-pin
 - One 4-pin and two 2-pin
 - Four 2-pin
- Selectable internal or external serial clock to allow wide range of baud rates
- Register compatibility with NS16550 register set
- Complete status reporting capability
- Fully programmable serial-interface characteristics
- Supports DMA using internal DMA function on PLB 64

IIC Bus Interface

Features include:

- Two IIC interfaces provided
- Support for Philips® Semiconductors I²C Specification, dated 1995
- Operation at 100kHz or 400kHz
- 8-bit data
- 10- or 7-bit address
- Slave transmitter and receiver
- Master transmitter and receiver
- Multiple bus masters
- Two independent 4 x 1 byte data buffers
- Twelve memory-mapped, fully programmable configuration registers
- One programmable interrupt request signal
- Provides full management of all IIC bus protocols
- Programmable error recovery
- Includes an integrated boot-strap controller (BSC) that is multiplexed with the IIC0 interface

Data Sheet

Serial Peripheral Interface (SPI/SCP)

The Serial Peripheral Interface (also known as the Serial Communications Port) is a full-duplex, synchronous, character-oriented (byte) port that allows the exchange of data with other serial devices. The SCP is a master on the serial port supporting a 3-wire interface (receive, transmit, and clock), and is a slave on the OPB.

Features include:

- Three-wire serial port interface
- Full-duplex synchronous operation
- SCP bus master
- OPB bus slave
- Programmable clock rate divider
- Clock inversion
- Reverse data
- Local data loop back for test

Universal Serial Bus (USB)

The USB interfaces provide both device and host support for version 1.1 and device support for version 2.0. Support for the USB 2.0 Transceiver Macrocell Interface (UTMI) specification is included.

Features include:

- USB 1.1 Host port with internal PHY
- USB 2.0 Device UTMI or USB 1.1 Device PHY
 - Device support provides 6 end points (3 in, 3 out)
 - 1024B FIFO (double buffering of 512B packets)
 - FIFOs are *not* shared between in and out endpoints
 - Endpoints *do not* support high-bandwidth isochronous transfers
 - Two USB 2.0 device end points have DMA dedicated channels (DMA to PLB 128)

NAND Flash Controller

The NAND Flash controller provides a simple interface between the EBC and up to four separate external NAND Flash devices. It provides both direct command, address, and data access to the external device as well as a memory-mapped linear region that generates data accesses. NAND Flash device data appears on the peripheral data bus.

Features include:

- 1 to 4 banks supported on EBC
- Direct Interfacing to:
 - Discrete NAND Flash devices (up to 4 devices)
 - SmartMedia Card socket (22-pins)
- Device sizes:
 - 4MB and larger supported for read/write access
 - 4MB to 256MB for boot-from-NAND flash (size supported depends on addressing mode)
- (512 + 16)-B or (2K + 64)-B device page sizes supported
- Boot-from-NAND: Execute a linear sequence of boot code out of the first 4KB of block 0
- Support DMA to allow direct, no-processor-intervention block copy from NAND Flash to SDRAM
- ECC provides single-bit error correction and double-bit error detection in each 256B of stored data
- Chip selects shared with EBC

General Purpose Timers (GPT)

Provides a separate time base counter and additional system timers in addition to those defined in the processor core.

Features include:

- 32-bit Time Base Counter driven by the OPB bus clock
- Seven 32-bit compare timers

General Purpose IO (GPIO) Controller

- Controller functions and GPIO registers are programmed and accessed via memory-mapped OPB bus master accesses.
- 64 GPIOs are multiplexed with other functions. DCRs control whether a particular pin that has GPIO capabilities acts as a GPIO or is used for another purpose.
- Each GPIO output is separately programmable to emulate an open drain driver (that is, drives to zero, tri-stated if output bit is 1).

Universal Interrupt Controller (UIC)

Two Universal Interrupt Controllers (UIC) are employed. They provide control, status, and communications necessary between the external and internal sources of interrupts and the on-chip PowerPC processor.

Note: Processor specific interrupts (for example, page faults) do not use UIC resources.

Features include:

- 10 external interrupts
- Edge triggered or level-sensitive
- Positive or negative active
- Non-critical or critical interrupt to the on-chip processor core
- Programmable interrupt priority ordering
- Programmable critical interrupt vector for faster vector processing

JTAG

Features include:

- IEEE 1149.1 Test Access Port
- IBM RISCWatch Debugger support
- JTAG Boundary Scan Description Language (BSDL)

Data Sheet

Package Diagram

Figure 3. 35mm, 456-Ball E-PBGA

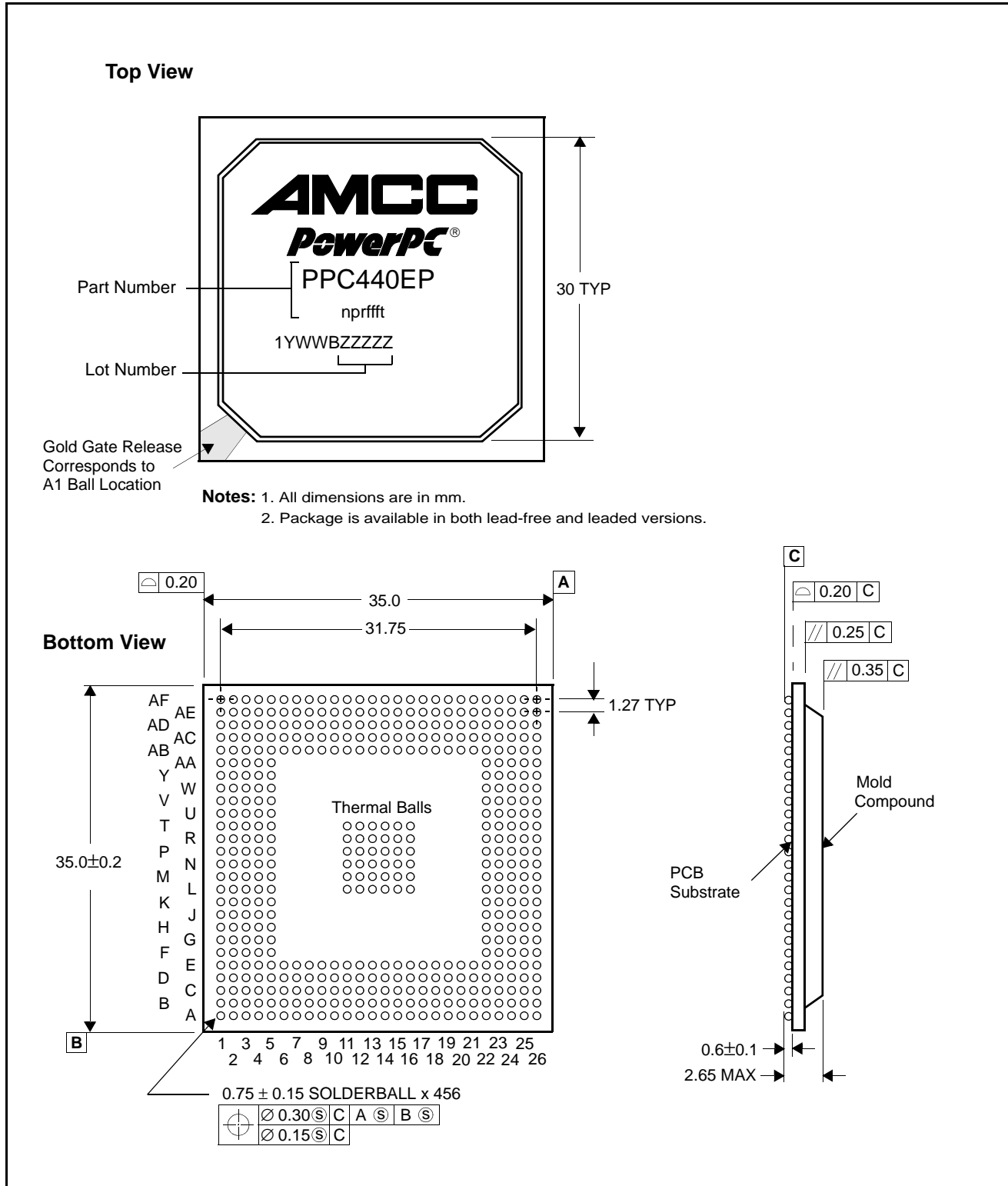

Assembly Recommendations

Table 3. Recommended Reflow Soldering Profile

Profile Feature	Sn-Pb Eutectic Assembly	Pb Free Reflow Assembly
Average ramp-up rate	3°C/second max	3°C/second max
Preheat <ul style="list-style-type: none"> – Temperature Min – Temperature Max – Time (min to max) 	100°C 150°C 60-120 Seconds	150°C 180°C 60-120 Seconds
Time Maintained Above: <ul style="list-style-type: none"> – Temperature – Time 	183°C 60-150 Seconds	230°C 30-50 Seconds
Peak Temperature	225 +0/-5°C	260 +5/-0°C
Time within 5°C of Actual Peak Temperature	10-30 Seconds	10-20 Seconds
Ramp-down Rate	6°C/Second Max	6°C/Second Max
Time 25°C to Peak Temperature	6 Minutes Max	8 Minutes Max

Table 4. JEDEC Moisture Sensitivity Level and Ball Composition

	Sn-Pb Eutectic Assembly	Pb Free Reflow Assembly
MSL Level	3	3
Solder Ball Metallurgy	63Sn/37Pb	Sn/4Ag/05Cu

Data Sheet**Signal Lists**

The following table lists all the external signals in alphabetical order and shows the ball (pin) number on which the signal appears. Multiplexed signals are shown with the default signal (following reset) *not* in brackets and alternate signals in brackets. Multiplexed signals appear alphabetically multiple times in the list—once for each signal name on the ball. The page number listed gives the page in “Signal Functional Description” on page 52 where the signals in the indicated interface group begin. In cases where signals in the same interface group (for example, Ethernet) have different names to distinguish variations in the mode of operation, the names are separated by a comma with the primary mode name appearing first. These signals are listed only once, and appear alphabetically by the primary mode name.

Alphabetical Signal List*Table 5. Signals Listed Alphabetically (Sheet 1 of 24)*

Signal Name	Ball	Interface Group	Page
AGND	AE17	Power	60
AV _{DD}	AD17		
BA0	AF03	DDR SDRAM	53
BA1	AF04		
BankSel0	R04	DDR SDRAM	53
BankSel1	R02		
BankSel2	R01		
BankSel3	N01		
[BusReq][USB2TermSel]GPIO31	AA23	External Master Peripheral	56
CAS	J02	DDR SDRAM	53
ClkEn	AF05	DDR SDRAM	53
DM0	AE05	DDR SDRAM	53
DM1	AD07		
DM2	J01		
DM3	L03		
DM8	AF07		
[DMAAck0][IRQ8]GPIO47	D18	External Slave Peripheral	55
[DMAAck1][IRQ4]GPIO44	G25		
[DMAAck2][PerAddr06]GPIO01	B06		
[DMAAck3][PerAddr03]GPIO04	C07		
[DMAReq0][IRQ7]GPIO46	B24	External Slave Peripheral	55
DMAReq1[IRQ5][ModeCtrl]	AC12		
[DMAReq2][PerAddr07]GPIO00	C08		
[DMAReq3][PerAddr04]GPIO03	D08		

Table 5. Signals Listed Alphabetically (Sheet 2 of 24)

Signal Name	Ball	Interface Group	Page
DQS0	AD09	DDR SDRAM	53
DQS1	AC08		
DQS2	K03		
DQS3	M04		
DQS8	AC06		
[DrvrInh1]USB2LS0[RejectPkt]	Y25	System	59
[DrvrInh2]Halt	C25		
ECC0	P02	DDR SDRAM	53
ECC1	N02		
ECC2	M01		
ECC3	M02		
ECC4	N03		
ECC5	N04		
ECC6	L02		
ECC7	M03	Ethernet	54
[EMCCD, EMC1RxErr]GPIO25[NFRdyBusy]	AC16		
[EMCCrS, EMC0CrSDV]GPIO22	AD15		
[EMCDV, EMC1CrSDV]GPIO21[NFREn]	AF17		
EMCMDClk	AE16		
EMCMDIO	AC18		
EMCRxCIk	AF19		
[EMCRxD0, EMC0RxD0, EMC0RxD]GPIO12	AD19		
[EMCRxD1, EMC0RxD1, EMC1RxD]GPIO13	AE20		
[EMCRxD2, EMC1RxD0]GPIO14	AD18		
[EMCRxD3, EMC1RxD1]GPIO15	AC17		
[EMCRxErr, EMC0RxErr]GPIO20	AD16		
EMCTxClk, EMCRRefClk	AC15		
[EMCTxD0, EMC0TxD0, EMC0TxD]GPIO16	AD14		
[EMCTxD1, EMC0TxD1, EMC1TxD]GPIO17	AF13		
[EMCTxD2, EMC1TxD0]GPIO18[NFCLE]	AF14		
[EMCTxD3, EMC1TxD1]GPIO19[NFALE]	AC14		
[EMCTxEEn, EMC0TxEn, EMCSync]GPIO24	AF20		
[EMCTxEErr, EMC1TxEn]GPIO23[NFWEn]	AF18		
[EOT0/TC0][IRQ9]GPIO48	A19		
[EOT1/TC1][IRQ6]GPIO45	H23		
[EOT2/TC2][PerAddr05]GPIO02	A05		
[EOT3/TC3][PerAddr02]GPIO05	B04		
[ExtAck][USB2XcvrSel]GPIO30	AA25	External Master Peripheral	56
[ExtReq][USB2RxErr]GPIO27	AD26	External Master Peripheral	56

Data Sheet

Table 5. Signals Listed Alphabetically (Sheet 3 of 24)

Signal Name	Ball	Interface Group	Page
ExtReset	B23	External Master Peripheral	56
GND	A01	Power	60
GND	A02		
GND	A06		
GND	A09		
GND	A11		
GND	A16		
GND	A21		
GND	A26		
GND	B02		
GND	B25		
GND	B26		
GND	C03		
GND	C24		
GND	D04		
GND	D21		
GND	D23		
GND	E09		
GND	E14		
GND	E18		
GND	F01		
GND	F26		
GND	J05		
GND	J22		
GND	J26		
GND	L01		
GND	L04		
GND	L11		
GND	L13		
GND	L14		
GND	L16		
GND	L26		
GND	M12		
GND	M13		

Table 5. Signals Listed Alphabetically (Sheet 4 of 24)

Signal Name	Ball	Interface Group	Page
GND	M15	Power	60
GND	M25		
GND	N05		
GND	N11		
GND	N13		
GND	N14		
GND	N15		
GND	N16		
GND	P11		
GND	P12		
GND	P13		
GND	P14		
GND	P16		
GND	P22		
GND	R12		
GND	R14		
GND	R15		
GND	T01		
GND	T11		
GND	T13		
GND	T14		
GND	T16		
GND	T26		
GND	V05		
GND	V01		
GND	V22		
GND	AA01		
GND	AA26		
GND	AB09		
GND	AB13		
GND	AB18		
GND	AC01		
GND	AC04		
GND	AC07		
GND	AC23		

Data Sheet

Table 5. Signals Listed Alphabetically (Sheet 5 of 24)

Signal Name	Ball	Interface Group	Page
GND	AD03	Power	60
GND	AD24		
GND	AE01		
GND	AE02		
GND	AE25		
GND	AF01		
GND	AF06		
GND	AF11		
GND	AF16		
GND	AF21		
GND	AF25		
GND	AF26		

Table 5. Signals Listed Alphabetically (Sheet 6 of 24)

Signal Name	Ball	Interface Group	Page
GPIO00[PerAddr07][DMAReq2]	C08	System	59
GPIO01[PerAddr06][DMAAck2]	B06		
GPIO02[PerAddr05][EOT2/TC2]	A05		
GPIO03[PerAddr04][DMAReq3]	D08		
GPIO04[PerAddr03][DMAAck3]	C07		
GPIO05[PerAddr02][EOT3/TC3]	B04		
GPIO06[PerCS1][NFCE1]	C06		
GPIO07[PerCS2][NFCE2]	A04		
GPIO08[PerCS3][NFCE3]	B07		
GPIO09[PerCS4]	B10		
GPIO10[PerCS5]	A10		
GPIO11[PerErr]	E04		
GPIO12[EMCRxD0, EMC0RxD0, EMC0RxD]	AD19		
GPIO13[EMCRxD1, EMC0RxD1, EMC1RxD]	AE20		
GPIO14[EMCRxD2, EMC1RxD0]	AD18		
GPIO15[EMCRxD3, EMC1RxD1]	AC17		
GPIO16[EMCTxD0, EMC0TxD0, EMC0TxD]	AD14		
GPIO17[EMCTxD1, EMC0TxD1, EMC1TxD]	AF13		
GPIO18[EMCTxD2, EMC1TxD0][NFCLE]	AF14		
GPIO19[EMCTxD3, EMC1TxD1][NFALE]	AC14		
GPIO20[EMCRxErr, EMC0RxErr]	AD16		
GPIO21[EMCDV, EMC1CrSDV][NFREn]	AF17		
GPIO22[EMCCrS, EMC0CrSDV]	AD15		
GPIO23[EMCTxErr, EMC1TxEn][NFWEn]	AF18		
GPIO24[EMCTxEn, EMC0TxEn, EMCSync]	AF20		
GPIO25[EMCCD, EMC1RxErr][NFRdyBusy]	AC16		
GPIO26[USB2RxDV]	AC26		
GPIO27[USB2RxErr][ExtReq]	AD26		
GPIO28[USB2TxVal]	Y24		
GPIO29[USB2Susp][HoldAck]	AB25		
GPIO30[USB2XcvtSel][ExtAck]	AA25		
GPIO31[USB2TermSel][BusReq]	AA23		

Data Sheet

Table 5. Signals Listed Alphabetically (Sheet 7 of 24)

Signal Name	Ball	Interface Group	Page
GPIO32[USB2OM0]	W24	System	59
GPIO33[USB2OM1]	AB26		
GPIO34[UART0_DCD/UART1_CTS/UART2_Tx]	R25		
GPIO35[UART0_DSR/UART1_RTS/UART2_Rx]	U26		
GPIO36[UART0_CTS/UART3_Rx]	V26		
GPIO37[UART0_RTS/UART3_Tx]	R26		
GPIO38[UART0_DTR/UART1_Tx]	N24		
GPIO39[UART0_RI/UART1_Rx]	P24		
GPIO40[IRQ0]	D03		
GPIO41[IRQ1]	G04		
GPIO42[IRQ2]	F02		
GPIO43[IRQ3]	G02		
GPIO44[IRQ4][DMAAck1]	G25		
GPIO45[IRQ6][EOT1/TC1]	H23		
GPIO46[IRQ7][DMAReq0]	B24		
GPIO47[IRQ8][DMAAck0]	D18		
GPIO48[IRQ9][EOT0/TC0]	A19		
GPIO49[TrcBS0]	AE21		
GPIO50[TrcBS1]	AC25		
GPIO51[TrcBS2]	AA24		
GPIO52[TrcES0]	Y03		
GPIO53[TrcES1]	AA04		
GPIO54[TrcES2]	AB03		
GPIO55[TrcES3]	AB04		
GPIO56[TrcES4]	AF22		
GPIO57[TrcTS0]	AC22		
GPIO58[TrcTS1]	AE24		
GPIO59[TrcTS2]	AD04		
GPIO60[TrcTS3]	AD06		
GPIO61[TrcTS4]	AC09		
GPIO62[TrcTS5]	AD12		
GPIO63[TrcTS6]	AE15		
Halt[DrvrInh2]	C25	System	59
[HoldAck][USB2Susp]GPIO29	AB25	External Master Peripheral	56
[HoldPri]USB2LS1[LeakTest]	V24		
[HoldReq]USB2RxAct[RcvrInh]	Y23		
IIC0SCK	U25	IIC0 Peripheral	56
IIC0SDATA	T24		

Table 5. Signals Listed Alphabetically (Sheet 8 of 24)

Signal Name	Ball	Interface Group	Page
[IIC1SClk]SCPClkOut	U24	IIC1 Peripheral	56
[IIC1SData]SCPDI	V25		
[IRQ0]GPIO40	D03	Interrupts	58
[IRQ1]GPIO41	G04		
[IRQ2]GPIO42	F02		
[IRQ3]GPIO43	G02		
[IRQ4]GPIO44[DMAAck1]	G25		
[IRQ5][ModeCtrl]DMAReq1	AC12		
[IRQ6]GPIO45[EOT1/TC1]	H23		
[IRQ7]GPIO46[DMAReq0]	B24		
[IRQ8]GPIO47[DMAAck0]	D18		
[IRQ9]GPIO48[EOT0/TC0]	A19		
[LeakTest]USB2LS1[HoldPri]	V24		
MemAddr00	P01	DDR SDRAM	53
MemAddr01	P04		
MemAddr02	T02		
MemAddr03	T04		
MemAddr04	U01		
MemAddr05	V02		
MemAddr06	U04		
MemAddr07	W03		
MemAddr08	Y02		
MemAddr09	AB02		
MemAddr10	R03		
MemAddr11	AD01		
MemAddr12	AD02		
MemClkOut0	AF12	DDR SDRAM	53
MemClkOut0	AE13		

Data Sheet

Table 5. Signals Listed Alphabetically (Sheet 9 of 24)

Signal Name	Ball	Interface Group	Page
MemData00	AE12	DDR SDRAM	53
MemData01	AD13		
MemData02	AC13		
MemData03	AE11		
MemData04	AF10		
MemData05	AE10		
MemData06	AC11		
MemData07	AF09		
MemData08	AE09		
MemData09	AD10		
MemData10	AF08		
MemData11	AE08		
MemData12	AC10		
MemData13	AE07		
MemData14	AD08		
MemData15	AD05		
MemData16	AE03		
MemData17	AC05		
MemData18	AF02		
MemData19	AC03		
MemData20	AC02		
MemData21	AA03		
MemData22	Y04		
MemData23	AA02		
MemData24	V04		
MemData25	Y01		
MemData26	V03		
MemData27	W02		
MemData28	W01		
MemData29	U03		
MemData30	T03		
MemData31	U02		
MemSelfRef	AE04	DDR SDRAM	53
[ModeCtrl][IRQ5]DMAReq1	AC12	System	59

Table 5. Signals Listed Alphabetically (Sheet 10 of 24)

Signal Name	Ball	Interface Group	Page
[NFALE][EMCTxD3, EMC1TxD1]GPIO19	AC14	NAND Flash	58
[NFCE0]PerCS0	D06		
[NFCE1][PerCS1]GPIO06	C06		
[NFCE2][PerCS2]GPIO07	A04		
[NFCE3][PerCS3]GPIO08	B07		
[NFCLE][EMCTxD2, EMC1TxD0]GPIO18	AF14		
[NFRdyBusy][EMCCD, EMC1RxErr]GPIO25	AC16		
[NFREn][EMCDV, EMC1CrSDV]GPIO21	AF17		
[NFWEn][EMCTxErr, EMC1TxEn]GPIO23	AF18		
No ball	F06	A physical ball does not exist at these ball coordinates.	NA
No ball	F07		
No ball	F08		
No ball	F09		
No ball	F10		
No ball	F11		
No ball	F12		
No ball	F13		
No ball	F14		
No ball	F15		
No ball	F16		
No ball	F17		
No ball	F18		
No ball	F19		
No ball	F20		
No ball	F21		
No ball	G06		
No ball	G07		
No ball	G08		
No ball	G09		
No ball	G10		
No ball	G11		
No ball	G12		
No ball	G13		
No ball	G14		
No ball	G15		

Data Sheet

Table 5. Signals Listed Alphabetically (Sheet 11 of 24)

Signal Name	Ball	Interface Group	Page
No ball	G16	A physical ball does not exist at these ball coordinates.	NA
No ball	G17		
No ball	G18		
No ball	G19		
No ball	G20		
No ball	G21		
No ball	H06		
No ball	H07		
No ball	H08		
No ball	H09		
No ball	H10		
No ball	H11		
No ball	H12		
No ball	H13		
No ball	H14		
No ball	H15		
No ball	H16		
No ball	H17		
No ball	H18		
No ball	H19		
No ball	H20		
No ball	H21		
No ball	J06		
No ball	J07		
No ball	J08		
No ball	J09		
No ball	J10		
No ball	J11		
No ball	J12		
No ball	J13		
No ball	J14		
No ball	J15		
No ball	J16		
No ball	J17		
No ball	J18		
No ball	J19		

Table 5. Signals Listed Alphabetically (Sheet 12 of 24)

Signal Name	Ball	Interface Group	Page
No ball	J20	A physical ball does not exist at these ball coordinates.	NA
No ball	J21		
No ball	K06		
No ball	K07		
No ball	K08		
No ball	K09		
No ball	K10		
No ball	K11		
No ball	K12		
No ball	K13		
No ball	K14		
No ball	K15		
No ball	K16		
No ball	K17		
No ball	K18		
No ball	K19		
No ball	K20		
No ball	K21		
No ball	L06		
No ball	L07		
No ball	L08		
No ball	L09		
No ball	L10		
No ball	L17		
No ball	L18		
No ball	L19		
No ball	L20		
No ball	L21		
No ball	M06		
No ball	M07		
No ball	M08		
No ball	M09		
No ball	M10		
No ball	M17		
No ball	M18		

Data Sheet

Table 5. Signals Listed Alphabetically (Sheet 13 of 24)

Signal Name	Ball	Interface Group	Page
No ball	M19	A physical ball does not exist at these ball coordinates.	NA
No ball	M20		
No ball	M21		
No ball	N06		
No ball	N07		
No ball	N08		
No ball	N09		
No ball	N10		
No ball	N17		
No ball	N18		
No ball	N19		
No ball	N20		
No ball	N21		
No ball	P06		
No ball	P07		
No ball	P08		
No ball	P09		
No ball	P10		
No ball	P17		
No ball	P18		
No ball	P19		
No ball	P20		
No ball	P21		
No ball	R06		
No ball	R07		
No ball	R08		
No ball	R09		
No ball	R10		
No ball	R17		
No ball	R18		
No ball	R19		
No ball	R20		
No ball	R21		
No ball	T06		
No ball	T07		
No ball	T08		

Table 5. Signals Listed Alphabetically (Sheet 14 of 24)

Signal Name	Ball	Interface Group	Page
No ball	T09	A physical ball does not exist at these ball coordinates.	NA
No ball	T10		
No ball	T17		
No ball	T18		
No ball	T19		
No ball	T20		
No ball	T21		
No ball	U06		
No ball	U07		
No ball	U08		
No ball	U09		
No ball	U10		
No ball	U11		
No ball	U12		
No ball	U13		
No ball	U14		
No ball	U15		
No ball	U16		
No ball	U17		
No ball	U18		
No ball	U19		
No ball	U20		
No ball	U21		
No ball	V06		
No ball	V07		
No ball	V08		
No ball	V09		
No ball	V10		
No ball	V11		
No ball	V12		
No ball	V13		
No ball	V14		
No ball	V15		
No ball	V16		
No ball	V17		

Data Sheet

Table 5. Signals Listed Alphabetically (Sheet 15 of 24)

Signal Name	Ball	Interface Group	Page
No ball	V18	A physical ball does not exist at these ball coordinates.	NA
No ball	V19		
No ball	V20		
No ball	V21		
No ball	W06		
No ball	W07		
No ball	W08		
No ball	W09		
No ball	W10		
No ball	W11		
No ball	W12		
No ball	W13		
No ball	W14		
No ball	W15		
No ball	W16		
No ball	W17		
No ball	W18		
No ball	W19		
No ball	W20		
No ball	W21		
No ball	Y06		
No ball	Y07		
No ball	Y08		
No ball	Y09		
No ball	Y10		
No ball	Y11		
No ball	Y12		
No ball	Y13		
No ball	Y14		
No ball	Y15		
No ball	Y16		
No ball	Y17		
No ball	Y18		
No ball	Y19		
No ball	Y20		
No ball	Y21		

Table 5. Signals Listed Alphabetically (Sheet 16 of 24)

Signal Name	Ball	Interface Group	Page
No ball	AA06	A physical ball does not exist at these ball coordinates.	NA
No ball	AA07		
No ball	AA08		
No ball	AA09		
No ball	AA10		
No ball	AA11		
No ball	AA12		
No ball	AA13		
No ball	AA14		
No ball	AA15		
No ball	AA16		
No ball	AA17		
No ball	AA18		
No ball	AA19		
No ball	AA20		
No ball	AA21		
OV _{DD}	E06	Power	60
OV _{DD}	E07		
OV _{DD}	E08		
OV _{DD}	E13		
OV _{DD}	E19		
OV _{DD}	E20		
OV _{DD}	E21		
OV _{DD}	F05		
OV _{DD}	F22		
OV _{DD}	G05		
OV _{DD}	G22		
OV _{DD}	H05		
OV _{DD}	H22		
OV _{DD}	L12		
OV _{DD}	L15		
OV _{DD}	M11		
OV _{DD}	M16		
OV _{DD}	N22		

Data Sheet

Table 5. Signals Listed Alphabetically (Sheet 17 of 24)

Signal Name	Ball	Interface Group	Page
PCIAD00	B16	PCI	52
PCIAD01	C15		
PCIAD02	D15		
PCIAD03	A17		
PCIAD04	B17		
PCIAD05	A18		
PCIAD06	C16		
PCIAD07	D16		
PCIAD08	C18		
PCIAD09	A20		
PCIAD10	C20		
PCIAD11	B22		
PCIAD12	A23		
PCIAD13	A24		
PCIAD14	C22		
PCIAD15	D22		
PCIAD16	H24		
PCIAD17	F25		
PCIAD18	J24		
PCIAD19	K23		
PCIAD20	K24		
PCIAD21	J25		
PCIAD22	L23		
PCIAD23	K25		
PCIAD24	K26		
PCIAD25	M24		
PCIAD26	M23		
PCIAD27	L25		
PCIAD28	N23		
PCIAD29	N26		
PCIAD30	M26		
PCIAD31	P26		
PCIC0/ $\overline{\text{BE0}}$	B18	PCI	52
PCIC1/ $\overline{\text{BE1}}$	F23		
PCIC2/ $\overline{\text{BE2}}$	F24		
PCIC3/ $\overline{\text{BE3}}$	E26	PCI	52
PCIClk	B21		
PCIDevSel	D26		
PCIFrame	G24	PCI	52

Table 5. Signals Listed Alphabetically (Sheet 18 of 24)

Signal Name	Ball	Interface Group	Page
$\overline{\text{PCIGnt0/Req}}$	D17	PCI	52
$\overline{\text{PCIGnt1}}$	L24		
$\overline{\text{PCIGnt2}}$	A25		
$\overline{\text{PCIGnt3}}$	D25		
$\overline{\text{PCIGnt4}}$	H25		
$\overline{\text{PCIGnt5}}$	E24		
$\overline{\text{PCIIDSel}}$	G26	PCI	52
$\overline{\text{PCIINT}}$	D20	PCI	52
$\overline{\text{PCIIRDY}}$	E25	PCI	52
$\overline{\text{PCIPar}}$	C23	PCI	52
$\overline{\text{PCIPErr}}$	D24	PCI	52
$\overline{\text{PCIReq0/Gnt}}$	N25	PCI	52
$\overline{\text{PCIReq1}}$	B20		
$\overline{\text{PCIReq2}}$	B19		
$\overline{\text{PCIReq3}}$	C19		
$\overline{\text{PCIReq4}}$	A22		
$\overline{\text{PCIReq5}}$	H26		
$\overline{\text{PCIReset}}$	D19	PCI	52
$\overline{\text{PCISerr}}$	J23	PCI	52
$\overline{\text{PCIStop}}$	E23	PCI	52
$\overline{\text{PCITRDY}}$	G23	PCI	52

Data Sheet

Table 5. Signals Listed Alphabetically (Sheet 19 of 24)

Signal Name	Ball	Interface Group	Page
[PerAddr02]GPIO05[EOT3/TC3]	B04	External Slave Peripheral	55
[PerAddr03]GPIO04[DMAAck3]	C07		
[PerAddr04]GPIO03[DMAReq3]	D08		
[PerAddr05]GPIO02[EOT2/TC2]	A05		
[PerAddr06]GPIO01[DMAAck2]	B06		
[PerAddr07]GPIO00[DMAReq2]	C08		
PerAddr08	D09		
PerAddr09	A07		
PerAddr10	C09		
PerAddr11	B08		
PerAddr12	D10		
PerAddr13	A08		
PerAddr14	B09		
PerAddr15	C10		
PerAddr16	C11		
PerAddr17	D12		
PerAddr18	C12		
PerAddr19	B11		
PerAddr20	B12		
PerAddr21	D13		
PerAddr22	A13		
PerAddr23	A12		
PerAddr24	A14		
PerAddr25	B13		
PerAddr26	C13		
PerAddr27	B14		
PerAddr28	A15		
PerAddr29	B15		
PerAddr30	C14		
PerAddr31	D14		
PerBLast	D11		
PerClk	C02	External Master Peripheral	56
PerCS0[NFCE0]	D06	External Slave Peripheral	55
[PerCS1][NFCE1]GPIO06	C06		
[PerCS2][NFCE2]GPIO07	A04		
[PerCS3][NFCE3]GPIO08	B07		
[PerCS4]GPIO09	B10		
[PerCS5]GPIO10	A10		

Table 5. Signals Listed Alphabetically (Sheet 20 of 24)

Signal Name	Ball	Interface Group	Page
PerData00	H01	External Slave Peripheral	55
PerData01	K04		
PerData02	G01		
PerData03	J03		
PerData04	J04		
PerData05	H03		
PerData06	E01		
PerData07	G03		
PerData08	H04		
PerData09	E02		
PerData10	D01		
PerData11	F03		
PerData12	C01		
PerData13	F04		
PerData14	E03		
PerData15	B01		
[PerErr]GPIO11	E04	External Master Peripheral	55
PerOE	B03	External Slave Peripheral	55
PerReady	C05	External Slave Peripheral	55
PerR \overline{W}	D05	External Slave Peripheral	55
PerWBE0	H02	External Slave Peripheral	55
PerWBE1	C04		
PSROOut	C26	System	59
RAS	K02	DDR SDRAM	53
[RcvrInh]USB2RxAct[HoldReq]	Y23	System	59
[RefEn]USB2TxRdy	W23	System	59
[RejectPkt]USB2LS0[DrvrInh1]	Y25	Ethernet	54
SAGND	AF15	Power	60
SAV _{DD}	AE14		
SCPClkOut[IIC1SClk]	U24	Serial Peripheral (SPI)	58
SCPDI[IIC1SData]	V25		
SCPDO	T23		

Data Sheet

Table 5. Signals Listed Alphabetically (Sheet 21 of 24)

Signal Name	Ball	Interface Group	Page
SV _{DD}	P05	Power	60
SV _{DD}	R11		
SV _{DD}	R16		
SV _{DD}	T12		
SV _{DD}	T15		
SV _{DD}	W05		
SV _{DD}	W22		
SV _{DD}	Y05		
SV _{DD}	Y22		
SV _{DD}	AA05		
SV _{DD}	AA22		
SV _{DD}	AB06		
SV _{DD}	AB07		
SV _{DD}	AB08		
SV _{DD}	AB14		
SV _{DD}	AB19		
SV _{DD}	AB20		
SV _{REF1}	W04		
SV _{REF2A}	P03		
SV _{REF2B}	AE06		
SysClk	AE19	System	59
SysErr	AB01	System	59
SysReset	AE18	System	59
TCK	B05	JTAG	58
TDI	C17	JTAG	58
TDO	C21	JTAG	58
TestEn	A03	System	59
TmrClk	AD11	System	59
TMS	D02	JTAG	58
[TrcBS0]GPIO49	AE21	Trace	60
[TrcBS1]GPIO50	AC25		
[TrcBS2]GPIO51	AA24		
TrcClk	AC19	Trace	60

Table 5. Signals Listed Alphabetically (Sheet 22 of 24)

Signal Name	Ball	Interface Group	Page
[TrcES0]GPIO52	Y03	Trace	60
[TrcES1]GPIO53	AA04		
[TrcES2]GPIO54	AB03		
[TrcES3]GPIO55	AB04		
[TrcES4]GPIO56	AF22		
[TrcTS0]GPIO57	AC22	Trace	60
[TrcTS1]GPIO58	AE24		
[TrcTS2]GPIO59	AD04		
[TrcTS3]GPIO60	AD06		
[TrcTS4]GPIO61	AC09		
[TrcTS5]GPIO62	AD12		
[TrcTS6]GPIO63	AE15		
$\overline{\text{TRST}}$	D07	JTAG	58
$\overline{\text{[UART0_CTS/UART3_Rx]GPIO36}}$	V26	UART Peripheral	56
$\overline{\text{[UART0_RTS/UART3_Tx]GPIO37}}$	R26		
UART0_Rx	T25		
UART0_Tx	P25		
$\overline{\text{[UART0_DCD/UART1_CTS/UART2_Tx]GPIO34}}$	R25		
$\overline{\text{[UART0_DSR/UART1_RTS/UART2_Rx]GPIO35}}$	U26		
$\overline{\text{[UART0_DTR/UART1_Tx]GPIO38}}$	N24		
$\overline{\text{[UART0_RI/UART1_Rx]GPIO39}}$	P24		
UARTSerClk	P23		

Data Sheet

Table 5. Signals Listed Alphabetically (Sheet 23 of 24)

Signal Name	Ball	Interface Group	Page
USB1Clk	AD25	Universal Serial Bus	57
USB1DevXcvr	R23		
USB1DevXcvr	R24		
USB1HostXcvr	W25		
USB1HostXcvr	W26		
USB2Clk	AD22		
USB2DI0	AD21		
USB2DI1	AE23		
USB2DI2	AF24		
USB2DI3	AC21		
USB2DI4	AE26		
USB2DI5	AB23		
USB2DI6	AC24		
USB2DI7	AB24		
USB2DO0	AD20		
USB2DO1	AE22		
USB2DO2	AC20		
USB2DO3	AF23		
USB2DO4	AD23		
USB2DO5	V23		
USB2DO6	Y26		
USB2DO7	U23		
USB2LS0[DrvrInh1][RejectPkt]	Y25		
USB2LS1[LeakTest][HoldPri]	V24		
[USB2OM0]GPIO32	W24		
[USB2OM1]GPIO33	AB26		
USB2RxAct[HoldReq][RcvrInh]	Y23		
[USB2RxDV]GPIO26	AC26		
[USB2RxErr]GPIO27[ExtReq]	AD26		
[USB2Susp]GPIO29[HoldAck]	AB25		
[USB2TermSel]GPIO31[BusReq]	AA23		
USB2TxRdy[RefEn]	W23		
[USB2TxVal]GPIO28	Y24		
[USB2XcvrSel]GPIO30[ExtAck]	AA25		

Table 5. Signals Listed Alphabetically (Sheet 24 of 24)

Signal Name	Ball	Interface Group	Page
V _{DD}	E05	Power	60
V _{DD}	E10		
V _{DD}	E11		
V _{DD}	E12		
V _{DD}	E15		
V _{DD}	E16		
V _{DD}	E17		
V _{DD}	E22		
V _{DD}	K05		
V _{DD}	K22		
V _{DD}	L05		
V _{DD}	L22		
V _{DD}	M05		
V _{DD}	M22		
V _{DD}	M14		
V _{DD}	N12		
V _{DD}	P15		
V _{DD}	R05		
V _{DD}	R13		
V _{DD}	R22		
V _{DD}	T05		
V _{DD}	T22		
V _{DD}	U05		
V _{DD}	U22		
V _{DD}	AB05		
V _{DD}	AB10		
V _{DD}	AB11		
V _{DD}	AB12		
V _{DD}	AB15		
V _{DD}	AB16		
V _{DD}	AB17		
V _{DD}	AB22		
$\overline{\text{WE}}$	K01	DDR SDRAM	53

Data Sheet**Signals in Ball Assignment Order**

In the following table, only the primary (default) signal name is shown for each pin. Multiplexed or multifunction signals are marked with an asterisk (*). To determine what signals or functions are multiplexed on those pins, look up the primary signal name in Table 5, *Signals Listed Alphabetically*.

Table 6. Signals Listed by Ball Assignment (Sheet 1 of 7)

Ball	Signal Name	Ball	Signal Name	Ball	Signal Name	Ball	Signal Name
A01	GND	B01	PerData15	C01	PerData12	D01	PerData10
A02	GND	B02	GND	C02	PerClk	D02	TMS
A03	TestEn	B03	$\overline{\text{PerOE}}$	C03	GND	D03	GPIO40*
A04	GPIO07*	B04	GPIO05*	C04	$\overline{\text{PerWBE1}}$	D04	GND
A05	GPIO02*	B05	TCK	C05	PerReady	D05	$\overline{\text{PerR}\overline{\text{W}}}$
A06	GND	B06	GPIO01*	C06	GPIO06*	D06	$\overline{\text{PerCS0}}$
A07	PerAddr09	B07	GPIO08*	C07	GPIO04*	D07	$\overline{\text{TRST}}$
A08	PerAddr13	B08	PerAddr11	C08	GPIO00*	D08	GPIO03*
A09	GND	B09	PerAddr14	C09	PerAddr10	D09	PerAddr08
A10	GPIO10*	B10	GPIO09*	C10	PerAddr15	D10	PerAddr12
A11	GND	B11	PerAddr19	C11	PerAddr16	D11	$\overline{\text{PerBLast}}$
A12	PerAddr23	B12	PerAddr20	C12	PerAddr18	D12	PerAddr17
A13	PerAddr22	B13	PerAddr25*	C13	PerAddr26*	D13	PerAddr21
A14	PerAddr24*	B14	PerAddr27*	C14	PerAddr30	D14	PerAddr31
A15	PerAddr28*	B15	PerAddr29*	C15	PCIAD01	D15	PCIAD02
A16	GND	B16	PCIAD00	C16	PCIAD06	D16	PCIAD07
A17	PCIAD03	B17	PCIAD04	C17	TDI	D17	$\overline{\text{PCI}\overline{\text{Gnt0}}/\overline{\text{Req}}}$
A18	PCIAD05	B18	PCIC0/ $\overline{\text{BE0}}$	C18	PCIAD08	D18	GPIO47*
A19	GPIO48*	B19	$\overline{\text{PCIReq2}}$	C19	$\overline{\text{PCIReq3}}$	D19	$\overline{\text{PCIRreset}}$
A20	PCIAD09	B20	$\overline{\text{PCIReq1}}$	C20	PCIAD10	D20	$\overline{\text{PCIINT}}$
A21	GND	B21	PCIClk	C21	TDO	D21	GND
A22	$\overline{\text{PCIReq4}}$	B22	PCIAD11	C22	PCIAD14	D22	PCIAD15
A23	PCIAD12	B23	$\overline{\text{ExtReset}}$	C23	PCIPar	D23	GND
A24	PCIAD13	B24	GPIO46*	C24	GND	D24	$\overline{\text{PCIPErr}}$
A25	$\overline{\text{PCI}\overline{\text{Gnt2}}}$	B25	GND	C25	$\overline{\text{Halt}}[\text{Drvrlnh2}]$	D25	$\overline{\text{PCI}\overline{\text{Gnt3}}}$
A26	GND	B26	GND	C26	PSROOut	D26	$\overline{\text{PCIDevSel}}$

Table 6. Signals Listed by Ball Assignment (Sheet 2 of 7)

Ball	Signal Name	Ball	Signal Name	Ball	Signal Name	Ball	Signal Name
E01	PerData06	F01	GND	G01	PerData02	H01	PerData00
E02	PerData09	F02	GPIO42*	G02	GPIO43*	H02	$\overline{\text{PerWBE0}}$
E03	PerData14	F03	PerData11	G03	PerData07	H03	PerData05
E04	GPIO11*	F04	PerData13	G04	GPIO41*	H04	PerData08
E05	V _{DD}	F05	OV _{DD}	G05	OV _{DD}	H05	OV _{DD}
E06	OV _{DD}	F06	No ball	G06	No ball	H06	No ball
E07	OV _{DD}	F07	No ball	G07	No ball	H07	No ball
E08	OV _{DD}	F08	No ball	G08	No ball	H08	No ball
E09	GND	F09	No ball	G09	No ball	H09	No ball
E10	V _{DD}	F10	No ball	G10	No ball	H10	No ball
E11	V _{DD}	F11	No ball	G11	No ball	H11	No ball
E12	V _{DD}	F12	No ball	G12	No ball	H12	No ball
E13	OV _{DD}	F13	No ball	G13	No ball	H13	No ball
E14	GND	F14	No ball	G14	No ball	H14	No ball
E15	V _{DD}	F15	No ball	G15	No ball	H15	No ball
E16	V _{DD}	F16	No ball	G16	No ball	H16	No ball
E17	V _{DD}	F17	No ball	G17	No ball	H17	No ball
E18	GND	F18	No ball	G18	No ball	H18	No ball
E19	OV _{DD}	F19	No ball	G19	No ball	H19	No ball
E20	OV _{DD}	F20	No ball	G20	No ball	H20	No ball
E21	OV _{DD}	F21	No ball	G21	No ball	H21	No ball
E22	V _{DD}	F22	OV _{DD}	G22	OV _{DD}	H22	OV _{DD}
E23	$\overline{\text{PCIStop}}$	F23	PCIC1/ $\overline{\text{BE1}}$	G23	$\overline{\text{PCITRDY}}$	H23	GPIO45*
E24	$\overline{\text{PCIgnt5}}$	F24	PCIC2/ $\overline{\text{BE2}}$	G24	$\overline{\text{PCIFrame}}$	H24	PCIAD16
E25	$\overline{\text{PCIIRDY}}$	F25	PCIAD17	G25	GPIO44*	H25	$\overline{\text{PCIgnt4}}$
E26	PCIC3/ $\overline{\text{BE3}}$	F26	GND	G26	PCIIDSel	H26	$\overline{\text{PCIReq5}}$

Data Sheet

Table 6. Signals Listed by Ball Assignment (Sheet 3 of 7)

Ball	Signal Name	Ball	Signal Name	Ball	Signal Name	Ball	Signal Name
J01	DM2	K01	\overline{WE}	L01	GND	M01	ECC2
J02	\overline{CAS}	K02	\overline{RAS}	L02	ECC6	M02	ECC3
J03	PerData03	K03	DQS2	L03	DM3	M03	ECC7
J04	PerData04	K04	PerData01	L04	GND	M04	DQS3
J05	GND	K05	V_{DD}	L05	V_{DD}	M05	V_{DD}
J06	No ball	K06	No ball	L06	No ball	M06	No ball
J07	No ball	K07	No ball	L07	No ball	M07	No ball
J08	No ball	K08	No ball	L08	No ball	M08	No ball
J09	No ball	K09	No ball	L09	No ball	M09	No ball
J10	No ball	K10	No ball	L10	No ball	M10	No ball
J11	No ball	K11	No ball	L11	GND	M11	OV_{DD}
J12	No ball	K12	No ball	L12	OV_{DD}	M12	GND
J13	No ball	K13	No ball	L13	GND	M13	GND
J14	No ball	K14	No ball	L14	GND	M14	V_{DD}
J15	No ball	K15	No ball	L15	OV_{DD}	M15	GND
J16	No ball	K16	No ball	L16	GND	M16	OV_{DD}
J17	No ball	K17	No ball	L17	No ball	M17	No ball
J18	No ball	K18	No ball	L18	No ball	M18	No ball
J19	No ball	K19	No ball	L19	No ball	M19	No ball
J20	No ball	K20	No ball	L20	No ball	M20	No ball
J21	No ball	K21	No ball	L21	No ball	M21	No ball
J22	GND	K22	V_{DD}	L22	V_{DD}	M22	V_{DD}
J23	$\overline{PCISERR}$	K23	PCIAD19	L23	PCIAD22	M23	PCIAD26
J24	PCIAD18	K24	PCIAD20	L24	$\overline{PCIgnt1}$	M24	PCIAD25
J25	PCIAD21	K25	PCIAD23	L25	PCIAD27	M25	GND
J26	GND	K26	PCIAD24	L26	GND	M26	PCIAD30

Table 6. Signals Listed by Ball Assignment (Sheet 4 of 7)

Ball	Signal Name	Ball	Signal Name	Ball	Signal Name	Ball	Signal Name
N01	BankSel3	P01	MemAddr00	R01	BankSel2	T01	GND
N02	ECC1	P02	ECC0	R02	BankSel1	T02	MemAddr02
N03	ECC4	P03	SV _{REF2A}	R03	MemAddr10	T03	MemData30
N04	ECC5	P04	MemAddr01	R04	BankSel0	T04	MemAddr03
N05	GND	P05	SV _{DD}	R05	V _{DD}	T05	V _{DD}
N06	No ball	P06	No ball	R06	No ball	T06	No ball
N07	No ball	P07	No ball	R07	No ball	T07	No ball
N08	No ball	P08	No ball	R08	No ball	T08	No ball
N09	No ball	P09	No ball	R09	No ball	T09	No ball
N10	No ball	P10	No ball	R10	No ball	T10	No ball
N11	GND	P11	GND	R11	SV _{DD}	T11	GND
N12	V _{DD}	P12	GND	R12	GND	T12	SV _{DD}
N13	GND	P13	GND	R13	V _{DD}	T13	GND
N14	GND	P14	GND	R14	GND	T14	GND
N15	GND	P15	V _{DD}	R15	GND	T15	SV _{DD}
N16	GND	P16	GND	R16	SV _{DD}	T16	GND
N17	No ball	P17	No ball	R17	No ball	T17	No ball
N18	No ball	P18	No ball	R18	No ball	T18	No ball
N19	No ball	P19	No ball	R19	No ball	T19	No ball
N20	No ball	P20	No ball	R20	No ball	T20	No ball
N21	No ball	P21	No ball	R21	No ball	T21	No ball
N22	OV _{DD}	P22	GND	R22	V _{DD}	T22	V _{DD}
N23	PCIAD28	P23	UARTSerCik	R23	USB1DevXcvr	T23	SCPDO
N24	GPIO38*	P24	GPIO39*	R24	USB1DevXcvr	T24	IIC0SData
N25	PCIReq0/Gnt	P25	UART0_Tx	R25	GPIO34*	T25	UART0_Rx
N26	PCIAD29	P26	PCIAD31	R26	GPIO37*	T26	GND

Data Sheet

Table 6. Signals Listed by Ball Assignment (Sheet 5 of 7)

Ball	Signal Name	Ball	Signal Name	Ball	Signal Name	Ball	Signal Name
U01	MemAddr04	V01	GND	W01	MemData28	Y01	MemData25
U02	MemData31	V02	MemAddr05	W02	MemData27	Y02	MemAddr08
U03	MemData29	V03	MemData26	W03	MemAddr07	Y03	GPIO52*
U04	MemAddr06	V04	MemData24	W04	SV _{REF1}	Y04	MemData22
U05	V _{DD}	V05	GND	W05	SV _{DD}	Y05	SV _{DD}
U06	No ball	V06	No ball	W06	No ball	Y06	No ball
U07	No ball	V07	No ball	W07	No ball	Y07	No ball
U08	No ball	V08	No ball	W08	No ball	Y08	No ball
U09	No ball	V09	No ball	W09	No ball	Y09	No ball
U10	No ball	V10	No ball	W10	No ball	Y10	No ball
U11	No ball	V11	No ball	W11	No ball	Y11	No ball
U12	No ball	V12	No ball	W12	No ball	Y12	No ball
U13	No ball	V13	No ball	W13	No ball	Y13	No ball
U14	No ball	V14	No ball	W14	No ball	Y14	No ball
U15	No ball	V15	No ball	W15	No ball	Y15	No ball
U16	No ball	V16	No ball	W16	No ball	Y16	No ball
U17	No ball	V17	No ball	W17	No ball	Y17	No ball
U18	No ball	V18	No ball	W18	No ball	Y18	No ball
U19	No ball	V19	No ball	W19	No ball	Y19	No ball
U20	No ball	V20	No ball	W20	No ball	Y20	No ball
U21	No ball	V21	No ball	W21	No ball	Y21	No ball
U22	V _{DD}	V22	GND	W22	SV _{DD}	Y22	SV _{DD}
U23	USB2DO7	V23	USB2DO5	W23	USB2TxRdy*	Y23	USB2RxAct*
U24	SCPClkOut*	V24	USB2LS1*	W24	GPIO32*	Y24	GPIO28*
U25	IIC0SCLk	V25	SCPDI*	W25	USB1HostXcvr	Y25	USB2LS0*
U26	GPIO35*	V26	GPIO36*	W26	USB1HostXcvr	Y26	USB2DO6

Table 6. Signals Listed by Ball Assignment (Sheet 6 of 7)

Ball	Signal Name	Ball	Signal Name	Ball	Signal Name	Ball	Signal Name
AA01	GND	AB01	SysErr	AC01	GND	AD01	MemAddr11
AA02	MemData23	AB02	MemAddr09	AC02	MemData20	AD02	MemAddr12
AA03	MemData21	AB03	GPIO54*	AC03	MemData19	AD03	GND
AA04	GPIO53*	AB04	GPIO55*	AC04	GND	AD04	GPIO59*
AA05	SV _{DD}	AB05	V _{DD}	AC05	MemData17	AD05	MemData15
AA06	No ball	AB06	SV _{DD}	AC06	DQS8	AD06	GPIO60*
AA07	No ball	AB07	SV _{DD}	AC07	GND	AD07	DM1
AA08	No ball	AB08	SV _{DD}	AC08	DQS1	AD08	MemData14
AA09	No ball	AB09	GND	AC09	GPIO61*	AD09	DQS0
AA10	No ball	AB10	V _{DD}	AC10	MemData12	AD10	MemData09
AA11	No ball	AB11	V _{DD}	AC11	MemData06	AD11	TmrClk
AA12	No ball	AB12	V _{DD}	AC12	IRQ5*	AD12	GPIO62*
AA13	No ball	AB13	GND	AC13	MemData02	AD13	MemData01
AA14	No ball	AB14	SV _{DD}	AC14	GPIO19*	AD14	GPIO16*
AA15	No ball	AB15	V _{DD}	AC15	EMCTxCIk*	AD15	GPIO22*
AA16	No ball	AB16	V _{DD}	AC16	GPIO25*	AD16	GPIO20*
AA17	No ball	AB17	V _{DD}	AC17	GPIO15*	AD17	AV _{DD}
AA18	No ball	AB18	GND	AC18	EMCMDIO	AD18	GPIO14*
AA19	No ball	AB19	SV _{DD}	AC19	TrcClk	AD19	GPIO12*
AA20	No ball	AB20	SV _{DD}	AC20	USB2DO2	AD20	USB2DO0
AA21	No ball	AB21	SV _{DD}	AC21	USB2DI3	AD21	USB2DI0
AA22	SV _{DD}	AB22	V _{DD}	AC22	GPIO57*	AD22	USB2Clk
AA23	GPIO31*	AB23	USB2DI5	AC23	GND	AD23	USB2DO4
AA24	GPIO51*	AB24	USB2DI7	AC24	USB2DI6	AD24	GND
AA25	GPIO30*	AB25	GPIO29*	AC25	GPIO50*	AD25	USB1Clk
AA26	GND	AB26	GPIO33*	AC26	GPIO26*	AD26	GPIO27*

Data Sheet

Table 6. Signals Listed by Ball Assignment (Sheet 7 of 7)

Ball	Signal Name	Ball	Signal Name	Ball	Signal Name	Ball	Signal Name
AE01	GND	AF01	GND				
AE02	GND	AF02	MemData18				
AE03	MemData16	AF03	BA0				
AE04	MemSelfRef	AF04	BA1				
AE05	DM0	AF05	ClkEn				
AE06	SV _{REF2B}	AF06	GND				
AE07	MemData13	AF07	DM8				
AE08	MemData11	AF08	MemData10				
AE09	MemData08	AF09	MemData07				
AE10	MemData05	AF10	MemData04				
AE11	MemData03	AF11	GND				
AE12	MemData00	AF12	MemClkOut0				
AE13	$\overline{\text{MemClkOut0}}$	AF13	GPIO17*				
AE14	SAV _{DD}	AF14	GPIO18*				
AE15	GPIO63*	AF15	SAGND				
AE16	EMCMDClk	AF16	GND				
AE17	AGND	AF17	GPIO21*				
AE18	$\overline{\text{SysReset}}$	AF18	GPIO23*				
AE19	SysClk	AF19	EMCRxClk				
AE20	GPIO13*	AF20	GPIO24*				
AE21	GPIO49*	AF21	GND				
AE22	USB2DO1	AF22	GPIO56*				
AE23	USB2DI1	AF23	USB2DO3				
AE24	GPIO58*	AF24	USB2DI2				
AE25	GND	AF25	GND				
AE26	USB2DI4	AF26	GND				

Signal Descriptions

The PPC440EP embedded controller is packaged in a 456-ball enhanced plastic ball grid array (E-PBGA). The following tables describe the package level pinout.

Table 7. Pin Summary

Group	No. of Pins
Total Signal Pins	304
AV _{DD}	1
SAV _{DD}	1
SAGnd	1
AGnd	1
OV _{DD}	18
SV _{DD}	18
V _{DD}	32
Gnd	80
Total Power Pins	152
Reserved	0
Total Pins	456

In the table “Signal Functional Description” on page 52, each I/O signal is listed along with a short description of its function. Active-low signals (for example, RAS) are marked with an overline. Please see “Signals Listed Alphabetically” on page 19 for the pin (ball) number to which each signal is assigned.

Multiplexed Signals

Some signals are multiplexed on the same pin so that the pin can be used for different functions. In most cases, the signal names shown in this table are not accompanied by signal names that may be multiplexed on the same pin. If you need to know what, if any, signals are multiplexed with a particular signal, look up the name in “Signals Listed Alphabetically” on page 19. It is expected that in any single application a particular pin will always be programmed to serve the same function. The flexibility of multiplexing allows a single chip to offer a richer pin selection than would otherwise be possible. The circuit type for multiplexed signals is shown as “Multiplex.” The actual circuit type is the same as the primary signal.

Note: Signals multiplexed with GPIO default to GPIO receivers and float after reset. Initialization software must configure the GPIO registers for the desired function as described in the GPIO Chapter of the User’s Manual. Any of these signals requiring a particular state prior to running initialization code must be terminated with pull ups or pull downs.

Multipurpose Signals

In addition to multiplexing, some pins are also multi-purpose. For example, the EBC peripheral controller address pins (PerAddr) are used as outputs by the PPC440EP to broadcast an address to external slave devices when the PPC440EP has control of the external bus. When during the course of normal chip operation an external master gains ownership of the external bus, these same pins are used as inputs which are driven by the external master and received by the EBC in the PPC440EP. In this example, the pins are also bidirectional, serving both as inputs and outputs.

Data Sheet

Multimode Signals

In some cases (for example, Ethernet) the function of a pin may vary with different modes of operation. When a pin has multiple signal names assigned to distinguish different modes of operation, all of the names are shown.

Strapping Pins

One group of pins is used as strapped inputs during system reset. These pins function as strapped inputs only during reset and are used for other functions during normal operation (see “Strapping” on page 86). Note that these are *not multiplexed* pins since the function of the pins is not programmable.

Unused I/Os

Termination of unused receivers is generally required; however there are some exceptions that reduce or eliminate the need for termination.

Signals Multiplexed with GPIO:

By Default after reset, signals shared with GPIO pins are configured as GPIO receivers. Termination however is not needed if the GPIO during initialization are configured as outputs. To configure as drivers, set and clear the appropriate bits in the GPIOx_ODR, GPIOx_TCR and GPIOx_OR registers as described in the GPIO chapter of the user’s manual.

PCI:

When the PCI bridge is unused, configure the PCI controller to park on the bus by pulling the PCIReq0 [Gnt] signal low. Parking forces the PLB3 to PCI bridge to actively drive PCIAD31:0 and PCIC3:0[BE3:0]. The remaining PCI control signals must be terminated as follows:

- Disable the internal PCI arbiter and enable PCI synchronous mode (See IIC Boot Strap Chapter in the user’s manual). (**Note:** Synchronous mode is not supported when operating the PCI bus. This mode should only be used for terminating an unused PCI interface).
- Individually connect PCISerr, PCIPerr, PCITRDY, and PCISstop through 3kΩ resistors to +3.3v.
- Terminate PCIReq1:5 through 3kΩ resistors to +3.3v.
- Terminate PCIReq0[Gnt] through a 1kΩ resistor to GND.

DDR:

When ECC is not used, no termination is needed for unused ECC signals (ECC0:7, DM8, and DS8).

USB Host:

When the USB Host interface is not used, a clock is still required for USB1Clk in order to reset the USB Host. If the USB Host does not reset, it can interfere with the internal PLB3 and OPB buses. The USB Host signals must be terminated as follows:

- A clock must be connected to USB1Clk. The clock can be any frequency from 32kHz to 48MHz.
- USB1HostXcvr and USB1HostXcv signals must be pulled down.

USB Device:

The USB Device requires a subset of the USB signals to be terminated.

- USB2LS0[DrvrInh1][RejectPkt] must be pulled by unless used as a packet reject input.
- USB2D10:7, USB1DevXcvr, USB1DevXcvr and USB2Clk signals must be pulled down.

SMII0, RMII0 or MII:

- Configure EMAC0 to use internal clocks by setting SDR0_MFR[E0CS]=1 and reset EMAC0 by setting EMAC0_MR0[SRST]=1.
- No pull ups or pull downs required

SMII1, RMII1 or MII:

- Configure EMAC1 to use internal clocks by setting SDR0_MFR[E1CS]=1 and reset EMAC1 by setting EMAC0_MR1[SRST]=1.
- No pull ups or downs required.

Table 8. Signal Functional Description (Sheet 1 of 9)

Notes:

1. Receiver input has hysteresis
2. Must pull up (recommended value is 3kΩ to 3.3V)
3. Must pull down (recommended value is 1kΩ)
4. If not used, must pull up (recommended value is 3kΩ to 3.3V)
5. If not used, must pull down (recommended value is 1kΩ)
6. Strapping input during reset; pull-up or pull-down required

Signal Name	Description	I/O	Type	Notes
PCI Interface				
PCIA00:31	Address/Data bus (bidirectional).	I/O	3.3V PCI	
PCIC0:3/BE0:3	PCI Command/Byte Enables.	I/O	3.3V PCI	
PCIClk	Provides timing to the PCI interface for PCI transactions.	I	3.3V PCI	5
PCIDevSel	Indicates the driving device has decoded its address as the target of the current access. (PCI 2.2 specification requires 8.2kΩ pull up on host system)	I/O	3.3V PCI	
PCIFrame	Driven by the current master to indicate beginning and duration of an access. (PCI 2.2 specification requires 8.2kΩ pull up on host system)	I/O	3.3V PCI	
PCIGnt0/Req	Indicates that the specified agent is granted access to the bus. When the internal arbiter is enabled, output is PCIGnt0. When the internal arbiter is disabled, output is Req.	O	3.3V PCI	
PCIGnt1:5	Indicates that the specified agent is granted access to the bus. Used only when internal PCI arbiter enabled.	O	3.3V PCI	
PCIIDSel	Used as a chip select during configuration read and write transactions.	I	3.3V PCI	
PCIINT	Level sensitive PCI interrupt.	O	3.3V PCI	
PCIIRDY	Indicates initiating agent's ability to complete the current data phase of the transaction. (PCI 2.2 specification requires 8.2kΩ pull up on host system)	I/O	3.3V PCI	
PCIPar	Even parity.	I/O	3.3V PCI	
PCIPErr	Reports data parity errors during all PCI transactions except a Special Cycle. (PCI 2.2 specification requires 8.2kΩ pull up on host system)	I/O	3.3V PCI	
PCIREQ0/Gnt	Indicates to the PCI arbiter that the specified agent wishes to use the bus. When the internal arbiter is enabled, input is PCIREQ0. When internal arbiter is disabled, input is Gnt. Note: When not using the PCI interface, use termination recommendation "Unused I/Os" on page 51.	I	3.3V PCI	4
PCIREQ1:5	An indication to the PCI arbiter that the specified agent wishes to use the bus. Used only when internal PCI arbiter enabled.	I	3.3V PCI	4
PCIReset	Brings PCI device registers and logic to a consistent state.	O	3.3V PCI	
PCISErr	Reports address parity errors, data parity errors on the Special Cycle command, or other catastrophic system errors. (PCI 2.2 specification requires 8.2kΩ pull up on host system)	I/O	3.3V PCI	
PCIStop	Current target is requesting the master to stop the current transaction. (PCI 2.2 specification requires 8.2kΩ pull up on host system)	I/O	3.3V PCI	
PCITRDY	Target agent's ability to complete the current data phase of the transaction. (PCI 2.2 specification requires 8.2kΩ pull up on host system)	I/O	3.3V PCI	

Data Sheet

Table 8. Signal Functional Description (Sheet 2 of 9)

Notes:

1. Receiver input has hysteresis
2. Must pull up (recommended value is 3k Ω to 3.3V)
3. Must pull down (recommended value is 1k Ω)
4. If not used, must pull up (recommended value is 3k Ω to 3.3V)
5. If not used, must pull down (recommended value is 1k Ω)
6. Strapping input during reset; pull-up or pull-down required

Signal Name	Description	I/O	Type	Notes
DDR SDRAM Interface				
BA0:1	Bank Address supporting up to four internal banks.	O	2.5V SSTL_2	
BankSel0:3	Selects up to four external DDR SDRAM banks.	O	2.5V SSTL_2	
$\overline{\text{CAS}}$	Column Address Strobe.	O	2.5V SSTL_2	
ClkEn	Clock Enable.	O	2.5V SSTL_2	
DM0:3 DM8	Memory write data byte lane masks. DM8 is the byte lane mask for the ECC byte lane.	O	2.5V SSTL_2	
DQS0:3 DQS8	Byte lane data strobe. DQS8 is the data strobe for the ECC byte lane.	I/O	2.5V SSTL_2	
ECC0:7	ECC check bits 0:7.	I/O	2.5V SSTL_2	
MemAddr00:12	Memory address bus.	O	2.5V SSTL_2	
MemClkOut0 MemClkOut0	Subsystem clock.	O	2.5V SSTL_2 Diff driver	
MemData00:31	Memory data bus.	I/O	2.5V SSTL_2	
MemSelfRef	Self refresh.	I	3.3V tolerant 2.5V CMOS	5
$\overline{\text{RAS}}$	Row Address Strobe.	O	2.5V SSTL_2	
$\overline{\text{WE}}$	Write Enable.	O	2.5V SSTL_2	
S _{VREF1}	SSTL reference voltage.	I	Volt ref receiver	
S _{VREF2A:B}	Supplemental SSTL reference voltage.	I	Volt ref pin (supplemental)	

Table 8. Signal Functional Description (Sheet 3 of 9)

Notes:

1. Receiver input has hysteresis
2. Must pull up (recommended value is 3kΩ to 3.3V)
3. Must pull down (recommended value is 1kΩ)
4. If not used, must pull up (recommended value is 3kΩ to 3.3V)
5. If not used, must pull down (recommended value is 1kΩ)
6. Strapping input during reset; pull-up or pull-down required

Signal Name	Description	I/O	Type	Notes
Ethernet Interface				
EMCCD, EMC1RxErr	MII: Collision detection. RMII1: Receive error.	I/O	3.3V tolerant 2.5V CMOS	
EMCCrS, EMC0CrSDV	MII: Carrier sense. RMII0: Carrier sense data valid.	I/O	3.3V tolerant 2.5V CMOS	
EMCDV, EMC1CrSDV	MII: Data valid. RMII1: Carrier sense data valid.	I/O	3.3V tolerant 2.5V CMOS	
EMCMDClk	MII, RMII, and SMII: Management data clock.	O	3.3V tolerant 2.5V CMOS	
EMCMDIO	MII, RMII, and SMII: Transfer command and status information with PHY.	I/O	3.3V tolerant 2.5V CMOS	
EMCRxCIk	MII: Receive clock.	I/O	3.3V tolerant 2.5V CMOS	
EMCRxD0:1, EMC0RxD0:1 EMC0:1RxD	MII: Receive data. RMII0: Receive data. SMII0 and SMII1: Receive data.	I/O	3.3V tolerant 2.5V CMOS	
EMCRxD2:3, EMC1RxD0:1	MII: Receive data. RMII1: Receive data.	I/O	3.3V tolerant 2.5V CMOS	
EMCRxErr, EMC0RxErr	MII: Receive error. RMII0: Receive error.	I/O	3.3V tolerant 2.5V CMOS	
EMCTxCIk, EMCRefClk	MII: Transmit clock. SMII: Reference clock (125MHz). RMII: Reference clock (50MHz).	I	3.3V tolerant 2.5V CMOS	
EMCTxD0:1, EMC0TxD0:1 EMC0:1TxD	MII: Transmit data. RMII0: Transmit data. SMII0 and SMII1: Transmit data.	I/O	3.3V tolerant 2.5V CMOS	
EMCTxD2:3, EMC1TxD0:1	MII: Transmit data. RMII1: Transmit data.	I/O	3.3V tolerant 2.5V CMOS	
EMCTxEn, EMC0TxEn, EMCSync	MII: Transmit data enabled. RMII0: Transmit data enabled. SMII: Sync signal. (Note: Redrive EMCSync when driving more than one load. EMCSync is a weak driver).	O	3.3V tolerant 2.5V CMOS	
EMCTxErr, EMC1TxEn	MII: Transmit error. RMII1: Transmit data enabled.	I/O	3.3V tolerant 2.5V CMOS	
RejectPkt	External request to reject a packet.	I	3.3V tolerant 2.5V CMOS	

Data Sheet

Table 8. Signal Functional Description (Sheet 4 of 9)

Notes:

1. Receiver input has hysteresis
2. Must pull up (recommended value is 3k Ω to 3.3V)
3. Must pull down (recommended value is 1k Ω)
4. If not used, must pull up (recommended value is 3k Ω to 3.3V)
5. If not used, must pull down (recommended value is 1k Ω)
6. Strapping input during reset; pull-up or pull-down required

Signal Name	Description	I/O	Type	Notes
External Slave Peripheral Interface				
DMAAck0:3	Used by the PPC440EP to indicate that data transfers have occurred.	O	Multiplex	
DMAReq0:3	Used by slave peripherals to indicate they are prepared to transfer data.	I	Multiplex	1
EOT0:3/TC0:3	End Of Transfer/Terminal Count.	I/O	Multiplex	1
PerAddr02:07	Peripheral address bus used by PPC440EP when not in external master mode, otherwise used by external master.	I/O	3.3V LVTTTL	1, 2
PerAddr08:31	Peripheral address bus used by PPC440EP when not in external master mode, otherwise used by external master.	I/O	3.3V LVTTTL	
$\overline{\text{PerBLast}}$	Used by either the peripheral controller, DMA controller, or external master to indicate the last transfer of a memory access.	I/O	3.3V LVTTTL	1, 4
$\overline{\text{PerCS0:5}}$	External peripheral device select.	O	3.3V LVTTTL	2
PerData00:15	Peripheral data bus used by PPC440EP when not in external master mode, otherwise used by external master. Note: PerData00 is the most significant bit (msb) on this bus.	I/O	3.3V LVTTTL	1
$\overline{\text{PerOE}}$	Used by either peripheral controller or DMA controller depending upon the type of transfer involved. When the PPC440EP is the bus master, it enables the selected device to drive the bus.	O	3.3V LVTTTL	2
PerReady	Used by a peripheral slave to indicate it is ready to transfer data.	I	3.3V LVTTTL	
PerR/ $\overline{\text{W}}$	Used by the PPC440EP when not in external master mode, as output by either the peripheral controller or DMA controller depending upon the type of transfer involved. High indicates a read from memory, low indicates a write to memory. Otherwise, it used by the external master as an input to indicate the direction of transfer.	I/O	3.3V LVTTTL	1, 2
$\overline{\text{PerWBE0:1}}$	External peripheral data bus byte enables.	I/O	3.3V LVTTTL	1, 2
PerErr	External Error. Used as an input to record external slave peripheral errors.	I/O	3.3V LVTTTL	1

Table 8. Signal Functional Description (Sheet 5 of 9)

Notes:

1. Receiver input has hysteresis
2. Must pull up (recommended value is 3kΩ to 3.3V)
3. Must pull down (recommended value is 1kΩ)
4. If not used, must pull up (recommended value is 3kΩ to 3.3V)
5. If not used, must pull down (recommended value is 1kΩ)
6. Strapping input during reset; pull-up or pull-down required

Signal Name	Description	I/O	Type	Notes
External Master Peripheral Interface				
BusReq	Bus Request. Used when the PPC440EP needs to regain control of peripheral interface from an external master.	O	Multiplex	
$\overline{\text{ExtAck}}$	External Acknowledgement. Used by the PPC440EP to indicate that a data transfer occurred.	O	Multiplex	
$\overline{\text{ExtReq}}$	External Request. Used by an external master to indicate it is prepared to transfer data.	I	Multiplex	1
$\overline{\text{ExtReset}}$	Peripheral Reset. Used by an external master and by synchronous peripheral slaves.	O	3.3V LVTTTL	
HoldAck	Hold Acknowledge. Used by the PPC440EP to transfer ownership of peripheral bus to an external master.	O	Multiplex	
HoldReq	Hold Request. Used by an external master to request ownership of the peripheral bus.	I	Multiplex	1, 5
HoldPri	Hold Primary. Used by an external master to indicate the priority of a given external master tenure.	I	Multiplex	
PerClk	Peripheral Clock. Used by an external master and by synchronous peripheral slaves.	O	3.3V LVTTTL	
UART Peripheral Interface				
UARTSerClk	Serial clock input that provides an alternative to the internally generated serial clock. Used in cases where the allowable internally generated clock rates are not satisfactory.	I	3.3V LVTTTL	1, 4
UARTn_Rx	UART Receive data.	I	3.3V LVTTTL	1, 4
UARTn_Tx	UART Transmit data.	O	3.3V LVTTTL	
$\overline{\text{UARTn_DCD}}$	UART Data Carrier Detect.	I	3.3V LVTTTL	6
$\overline{\text{UARTn_DSR}}$	UART Data Set Ready.	I	3.3V LVTTTL	6
$\overline{\text{UARTn_CTS}}$	UART Clear To Send.	I	3.3V LVTTTL	1, 6
$\overline{\text{UARTn_DTR}}$	UART Data Terminal Ready.	O	3.3V LVTTTL	
$\overline{\text{UARTn_RTS}}$	UART Request To Send.	O	3.3V LVTTTL	
UARTn_RI	UART Ring Indicator.	I	3.3V LVTTTL	1
IIC Peripheral Interface				
IIC0SClk	IIC0 Serial Clock.	I/O	3.3V LVTTTL	1, 2
IIC0SData	IIC0 Serial Data.	I/O	3.3V LVTTTL	1, 2
IIC1SClk	IIC1 Serial Clock.	I/O	Multiplex	2
IIC1SData	IIC1 Serial Data.	I/O	Multiplex	2

Data Sheet

Table 8. Signal Functional Description (Sheet 6 of 9)

Notes:

1. Receiver input has hysteresis
2. Must pull up (recommended value is 3k Ω to 3.3V)
3. Must pull down (recommended value is 1k Ω)
4. If not used, must pull up (recommended value is 3k Ω to 3.3V)
5. If not used, must pull down (recommended value is 1k Ω)
6. Strapping input during reset; pull-up or pull-down required

Signal Name	Description	I/O	Type	Notes
USB/UTMI Peripheral Interface				
USB2DI0:7	Unidirectional data inputs.	I	3.3V tolerant 2.5V CMOS	5
USB2DO0:7	Unidirectional data outputs.	O	3.3V tolerant 2.5V CMOS	
USB2TxRdy	Transmit data ready.	I	3.3V tolerant 2.5V CMOS	
USB2RxAct	Receive active.	I	3.3V tolerant 2.5V CMOS	
USB2RxDV	Receive data valid.	I	3.3V tolerant 2.5V CMOS	
USB2RxErr	Receive error.	I	3.3V tolerant 2.5V CMOS	
USB2LS0	Line state 0.	I	3.3V tolerant 2.5V CMOS	2
USB2LS1	Line state 1.	I	3.3V tolerant 2.5V CMOS	
USB2TxVal	Transmit valid.	O	3.3V tolerant 2.5V CMOS	
USB2Susp	Suspend.	O	3.3V tolerant 2.5V CMOS	
USB2XcvrSel	Transceiver select.	O	3.3V tolerant 2.5V CMOS	
USB2TermSel	Termination select.	O	3.3V tolerant 2.5V CMOS	
USB2OM0:1	Operational mode.	O	3.3V tolerant 2.5V CMOS	
USB1HostXcvr USB1HostXcvr	USB 1.1 Host differential transceiver.	I/O	5V tolerant USB diff xcvr	5
USB1DevXcvr USB1DevXcvr	USB 1.1 Device differential transceiver.	I/O	5V tolerant USB diff xcvr	5
USB2Clk	USB 2.0 Clock Requires 60MHz signal for operation in 1.1 or 2.0 mode.	I	3.3V tolerant 2.5V CMOS	5
USB1Clk	USB 1.1 Host Clock (48MHz) Note: If not used for USB, must be connected to a clock signal with a frequency between 32kHz and 48MHz.	I	3.3V tolerant 2.5V CMOS	

Table 8. Signal Functional Description (Sheet 7 of 9)

Notes:

1. Receiver input has hysteresis
2. Must pull up (recommended value is 3kΩ to 3.3V)
3. Must pull down (recommended value is 1kΩ)
4. If not used, must pull up (recommended value is 3kΩ to 3.3V)
5. If not used, must pull down (recommended value is 1kΩ)
6. Strapping input during reset; pull-up or pull-down required

Signal Name	Description	I/O	Type	Notes
NAND Flash Interface				
NFALE	Address Latch Enable.	O	Multiplex	
NFCE0:3	Chip Enable (multiplexed with the $\overline{\text{PerCS0:3}}$ signals).	O	Multiplex	
NFCLE	Command Latch Enable.	O	Multiplex	
$\overline{\text{NFRdyBusy}}$	Ready/Busy. Indicates status of device during program erase or page read. This signal is wire-or connected from all NAND Flash devices.	I	Multiplex	
$\overline{\text{NFREn}}$	Read Enable strobe.	O	Multiplex	
$\overline{\text{NFWEn}}$	Write Enable strobe.	O	Multiplex	
Serial Peripheral Interface				
SCPClkOut	Clock output.	O	3.3V LVTTTL	2
SCPDI	Data In.	I	3.3V LVTTTL	2
SCPDO	Data output.	O	3.3V LVTTTL	2
Interrupts Interface				
IRQ0:4	External interrupt requests 0 through 4.	I/O	3.3V LVTTTL	1
IRQ5	External interrupt request 5.	I	3.3V tolerant 2.5V CMOS	1
IRQ6:9	External interrupt requests 6 through 9.	I/O	3.3V LVTTTL	1
JTAG Interface				
TCK	Test Clock.	I	3.3V LVTTTL w/pull-up	1
TDI	Test Data In.	I	3.3V LVTTTL w/pull-up	4
TDO	Test Data Out.	O	3.3V LVTTTL	
TMS	Test Mode Select.	I	3.3V LVTTTL w/pull-up	1
$\overline{\text{TRST}}$	Test Reset. Note: Must be asserted low during a power-on system reset in order to reset the JTAG interface. If the JTAG interface is not reset, the processor may not boot.	I	3.3V LVTTTL w/pull-up	5

Data Sheet

Table 8. Signal Functional Description (Sheet 8 of 9)

Notes:

1. Receiver input has hysteresis
2. Must pull up (recommended value is 3kΩ to 3.3V)
3. Must pull down (recommended value is 1kΩ)
4. If not used, must pull up (recommended value is 3kΩ to 3.3V)
5. If not used, must pull down (recommended value is 1kΩ)
6. Strapping input during reset; pull-up or pull-down required

Signal Name	Description	I/O	Type	Notes
System Interface				
SysClk	Main system clock input.	Clock	3.3V tolerant 2.5V CMOS	
SysErr	Set to 1 by an instruction machine check. The machine check is a result of the attempted execution of an instruction transferred on the PLB with a bus error. This output signal remains a logic 1 until the machine check error is cleared in the Exception Syndrome Register (ESR).	O	3.3V tolerant 2.5V CMOS	
SysReset	Main system reset. External logic can drive this bidirectional pin low (minimum of 16 cycles) to initiate a system reset. A system reset can also be initiated by software. Implemented as an open-drain output (two states; 0 or open circuit).	I/O	3.3V tolerant 2.5V CMOS	1, 2
Halt	Halt from external debugger.	I	3.3V LVTTTL	1, 2
TmrClk	Processor timer external input clock.	I	3.3V tolerant 2.5V CMOS	
GPIO0:63	General purpose I/O 0 through 63. To access these functions, software must set DCR register bits.	I/O	Multiplex	
TestEn	Test Enable.	I	3.3V LVTTTL	3
RcvrInh	Receiver Inhibit. Active only when TestEn is active. Used for manufacturing test only.	I	Multiplex	
ModeCtrl	Mode Control. Active only when TestEn is active. Used for manufacturing test only.	I	Multiplex	
LeakTest	Leakage Test. Active only when TestEn is active. Used for manufacturing test only.	I	Multiplex	
RefEn	Reference Enable. Active only when TestEn is active. Used for manufacturing test only.	I	Multiplex	
DrvrInh1	Driver Inhibit. Active only when TestEn is active. Used for manufacturing test only.	I	3.3V tolerant 2.5V CMOS	
DrvrInh2	Driver Inhibit. Active only when TestEn is active. Used for manufacturing test only.	I	3.3V LVTTTL	
PSROOut	Module characterization and screening. Use for test purposes only. Tie down as specified in Note 3 for normal operation.	O	Perf screen ring osc	1, 3

Table 8. Signal Functional Description (Sheet 9 of 9)

Notes:

1. Receiver input has hysteresis
2. Must pull up (recommended value is 3kΩ to 3.3V)
3. Must pull down (recommended value is 1kΩ)
4. If not used, must pull up (recommended value is 3kΩ to 3.3V)
5. If not used, must pull down (recommended value is 1kΩ)
6. Strapping input during reset; pull-up or pull-down required

Signal Name	Description	I/O	Type	Notes
Trace Interface				
TrcBS0:2	Trace branch execution status.	I/O	3.3V tolerant 2.5V CMOS	
TrcClk	Trace data capture clock, runs at 1/4 the frequency of the processor.	O	3.3V tolerant 2.5V CMOSL	
TrcES0:4	Trace Execution Status is presented every fourth processor clock cycle.	I/O	3.3V tolerant 2.5V CMOS	
TrcTS0:6	Additional information on trace execution and branch status.	I/O	3.3V tolerant 2.5V CMOS	
Power				
V _{DD}	1.5V supply—Logic voltage.	na	na	
OV _{DD}	3.3V supply—I/O (except DDR SDRAM, Ethernet).	na	na	
SV _{DD}	2.5V supply—SDRAM, Ethernet.	na	na	
GND	Ground.	na	na	
AV _{DD}	1.5V—Filtered voltage for system PLLs (analog).	na	na	
AGND	PLL (analog) voltage ground.	na	na	
SAV _{DD}	1.5V—Filtered voltage for memory PLL (analog).	na	na	
SAGND	PLL (analog) memory voltage ground.	na	na	

Data Sheet**Device Characteristics***Table 9. Absolute Maximum Ratings*

The absolute maximum ratings below are stress ratings only. Operation at or beyond these maximum ratings can cause permanent damage to the device. None of the performance specification contained in this document are guaranteed when operating at these maximum ratings.

Characteristic	Symbol	Value	Unit	Notes
Supply Voltage (Internal Logic)	V_{DD}	0 to +1.65	V	1
Supply Voltage (I/O, except SDRAM, Ethernet)	OV_{DD}	0 to +3.6	V	1
Supply Voltage (SDRAM, Ethernet)	SV_{DD}	0 to +2.7	V	
PLL Supply Voltage	AV_{DD}	0 to +1.65	V	2
SDRAM PLL Supply Voltage	SAV_{DD}	0 to +1.65	V	2
Input Voltage (3.3V LVTTTL receivers)	V_{IN}	0 to +3.6	V	
Storage Temperature Range	T_{STG}	-55 to +150	°C	
Case temperature under bias	T_C	-40 to +120	°C	2

Notes:

1. If $OV_{DD} \leq 0.4V$, it is required that $V_{DD} \leq 0.4V$. Supply excursions not meeting this criteria must be limited to less than 25ms duration during each power up or power down event.
2. This value is not a specification of the operational temperature range, it is a stress rating only.

Table 10. Recommended DC Operating Conditions (Sheet 1 of 2)

Device operation beyond the conditions specified is not recommended. Extended operation beyond the recommended conditions can affect device reliability.

Parameter	Symbol	Minimum	Typical	Maximum	Unit	Notes
Logic Supply Voltage	V_{DD}	+1.4	+1.5	+1.6	V	
I/O Supply Voltage	OV_{DD}	+3.0	+3.3	+3.6	V	
SDRAM Supply Voltage	SV_{DD}	+2.3	+2.5	+2.7	V	
PLL Supply Voltages	AV_{DD}	+1.4	+1.5	+1.6	V	3
SDRAM PLL Voltage	SAV_{DD}	+1.4	+1.5	+1.6	V	3
DDR SDRAM Reference Voltage	SV_{REF}	+1.15	+1.25	+1.35	V	2
Input Logic High (2.5V SSTL)	V_{IH}	$SV_{REF}+0.18$		$SV_{DD}+0.3$	V	
Input Logic High (2.5V CMOS, 3.3V tolerant receiver)		1.7			V	
Input Logic High (3.3V PCI)		$0.5OV_{DD}$		$OV_{DD}+0.5$	V	1
Input Logic High (3.3V LVTTTL)		+2.0		+3.6	V	

Table 10. Recommended DC Operating Conditions (Sheet 2 of 2)

Device operation beyond the conditions specified is not recommended. Extended operation beyond the recommended conditions can affect device reliability.

Parameter	Symbol	Minimum	Typical	Maximum	Unit	Notes
Input Logic Low (2.5V SSTL)	V _{IL}	-0.3		S _V REF-0.18	V	
Input Logic Low (2.5V CMOS, 3.3V tolerant receiver)				0.7	V	
Input Logic Low (3.3V PCI)		-0.5		0.35OV _{DD}	V	1
Input Logic Low (3.3V LVTTTL)		0		+0.8	V	
Output Logic High (2.5V SSTL)	V _{OH}	+1.95		S _V DD	V	
Output Logic High (2.5V CMOS, 3.3V tolerant receiver)		2.0		S _V DD	V	
Output Logic High (3.3V PCI)		0.9OV _{DD}		OV _{DD}	V	1
Output Logic High (3.3V LVTTTL)		+2.4		OV _{DD}	V	
Output Logic Low (2.5V SSTL)	V _{OL}	0		0.55	V	
Output Logic Low (2.5V CMOS, 3.3V tolerant receiver)				0.4	V	
Output Logic Low (3.3V PCI)				0.1OV _{DD}	V	1
Output Logic Low (3.3V LVTTTL)		0		+0.4	V	
Input Leakage Current (No pull-up or pull-down)	I _{IL1}	0		0	μA	
Input Leakage Current for Pull-Down	I _{IL2}	0 (LPDL)		200 (MPUL)	μA	
Input Leakage Current for Pull-Up	I _{IL3}	-150 (LPDL)		0 (MPUL)	μA	
Input Max Allowable Overshoot (3.3V LVTTTL)	V _{IMAO}			+3.9	V	4, 5
Input Max Allowable Undershoot (3.3V LVTTTL)	V _{IMAU}	-0.6			V	4, 5
Output Max Allowable Overshoot (3.3V LVTTTL)	V _{OMAO}			+3.9	V	4, 5
Output Max Allowable Undershoot (3.3V LVTTTL)	V _{OMAU3}	-0.6			V	4, 5
Case Temperature: 333MHz and 400MHz parts 533MHz parts 667MHz parts	T _C	-40 -40 -40		+90 +100 +85	°C	

Notes:

1. PCI drivers meet PCI specifications.
2. S_VREF = S_VDD/2
3. The analog voltages used for the on-chip PLLs can be derived from the logic voltage, but must be filtered before entering the PPC440EP. See “Absolute Maximum Ratings” on page 61.
4. Overshoot and undershoot voltages are for 10% duty cycle.
5. The time for overshoot or undershoot is time above OV_{DD} and the time below 0V.

Data Sheet

Figure 4. Overshoot Waveform

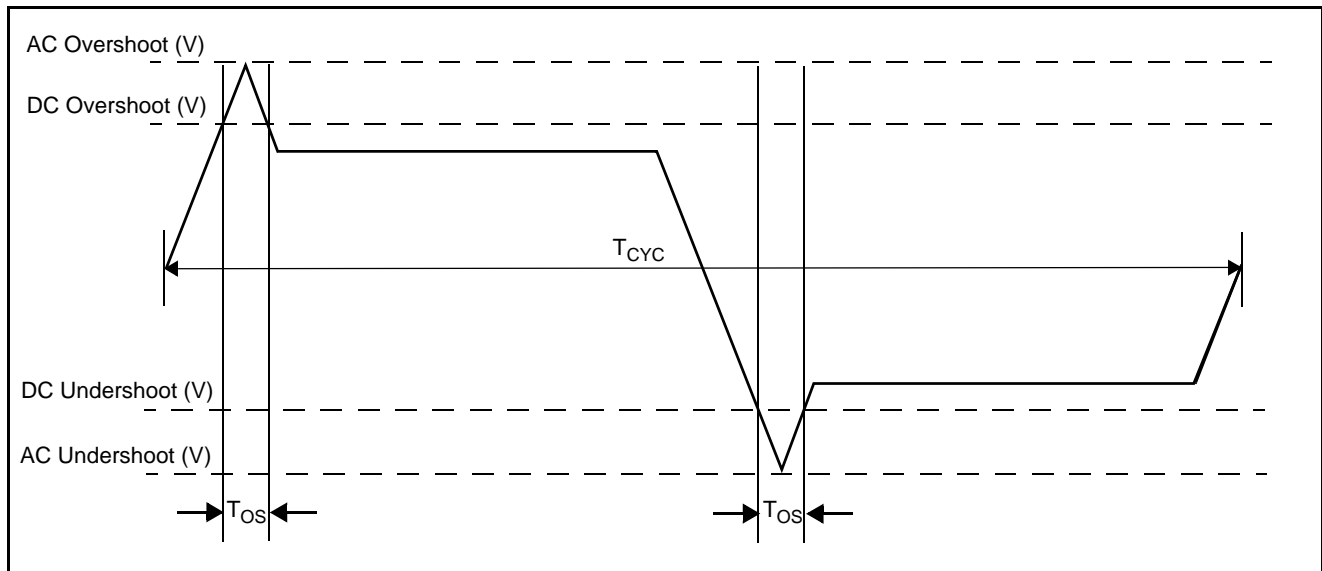

Table 11. Overshoot and Undershoot

Receiver	AC Overshoot (V)	DC Overshoot (V)	DC Undershoot (V)	AC Undershoot (V)	T_{OS}
3.3V LVTTTL	3.9	3.6	0	-0.6	$0.1 \cdot T_{CYC}^1$
2.5V (3.3V tolerant)	3.9	3.6	0	-0.6	$0.1 \cdot T_{CYC}^1$
DDR	$1.2 \cdot SOV_{DD}$	$SOV_{DD} + 0.3$	0	-0.6	$0.1 / MemClkOut$
PCI	$1.2 \cdot OV_{DD}$	$OV_{DD} + 0.5$	0	$-0.2 \cdot OV_{DD}$	$0.1 / PCIClk$

Notes:

- T_{CYC} is the period of the bus clock.
 1/PerClk - EBC and NAND flash interfaces.
 1/EMCRXCk - MII mode
 1/EMCRefclk - RMI mode
 1/SMIIRefClk - SMII mode
 1/USB2Clk - UTM
 1/TrcClk - instruction trace interface
 1/IIC0Clk and 1/IIC1Clk - IIC interfaces
 1/SPICkOut - SPI

Power Sequencing

Startup sequencing of the power supply voltages is not required. However, a power-down cycle must complete (OV_{DD} and V_{DD} are below +0.4V) before a new power-up cycle is started.

Analog Voltage Filter

The analog voltages used for the on-chip PLLs can be derived from the logic voltage, but must be filtered before entering the PPC440EP. A Separate filter, as shown below, is recommended for each voltage.

- The filter should keep the AV_{DD} -AGND (SAGND-SAGND) compression/expansion due to noise less than ± 50 mV.
- All wire of the filter circuit should be kept as short as possible to minimize coupling from other signals.
- AGND (SAGND) must be connected to the digital ground plane at the AV_{DD} (SAV_{DD}) capacitor.
- The impedance of the ferrite bead should be much greater than that of the capacitor at frequencies where noise is expected.

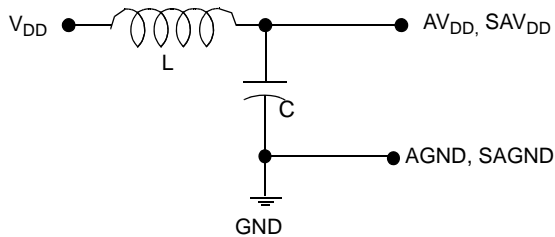

L – SMT ferrite bead chip, Murata BLM21PG600SN1
 C – 0.1 μ F ceramic

Data Sheet**Power Specifications**

The following tables contain measured power numbers. The measurement conditions are listed as **Notes** below each table.

Table 12. Typical DC Power Supply Requirements

Frequency (MHz)	+1.5V Supply ($V_{DD}+AV_{DD}+SAV_{DD}$)	+2.5V Supply (SV_{DD})	+3.3V Supply (OV_{DD})	Total	Unit	Notes
333	1.15	1.15	0.04	2.34	W	1
400	1.24	1.15	0.04	2.43	W	1
533	1.43	1.15	0.04	2.62	W	1
667	2.08	1.15	0.04	3.27	W	1

Notes:

1. Typical Power is based on nominal voltage of $V_{DD} = +1.5V$ and $T_C = \text{max.}$ specified in Table 10 on page 61, while running Linux and a test application that exercises each core with representative traffic.

Table 13. V_{DD} Supply Power Dissipation

Frequency (MHz)	+1.4V	+1.5V	+1.6V	Unit	Notes
333	0.96	1.15	1.38	W	1
400	1.04	1.24	1.49	W	1
533	1.20	1.43	1.71	W	1
667	1.74	2.08	2.52	W	1

Notes:

1. Power is based on V_{DD} specified in the table and $T_C = \text{max.}$ specified in Table 10 on page 61, while running Linux and a test application that exercises each core with representative traffic.

Table 14. DC Power Supply Current Loads

Parameter	Symbol	Typical	Maximum	Unit	Notes
V _{DD} (1.5V) active operating current	I _{DD}	1380	2200	mA	
OV _{DD} (3.3V) active operating current	I _{ODD}	10	100	mA	
SV _{DD} (2.5V) active operating current	I _{SDD}	460	600	mA	
AV _{DD} (1.5V) input current	I _{ADD}	3.2	5	mA	1
SAV _{DD} (1.5V) active operating current	I _{SADD}	6.05	10	mA	1

Notes:

1. See “Absolute Maximum Ratings” on page 61 for filter recommendations.
2. The maximum current values listed above are not guaranteed to be the highest obtainable. These values are dependent on many factors including the type of applications running, clock rates, use of internal functional capabilities, external interface usage, case temperature, and the power supply voltages. Your specific application can produce significantly different results. V_{DD} current and power are primarily dependent on the applications running and the use of internal chip functions (DMA, PCI, Ethernet, and so on). OV_{DD} current and power are primarily dependent on the capacitive loading, frequency, and utilization of the external buses.
3. Typical current is estimated at 667MHz with V_{DD} = +1.5V, OV_{DD} = +3.3V, SV_{DD} = +2.5V, and T_C = +85°C, while running Linux and a test application that exercises each core with representative traffic.
4. Maximum current is estimated at 667MHz with V_{DD} = +1.6V, OV_{DD} = +3.6V, SV_{DD} = +2.7V, T_C = +85°C, and a best-case process (which drives worst-case power), while running Linux and a test application that exercises each core with representative traffic.

Data Sheet**Package Thermal Specifications***Table 15. Package Thermal Specifications*

Thermal resistance values for the E-PBGA and TE-PBGA package are as follows:

Parameter	Symbol	Package	Airflow ft/min (m/sec)			Unit	Notes
			0 (0)	100 (0.51)	200 (1.02)		
Junction-to-ambient thermal resistance without heat sink	θ_{JA}	E-PBGA	20.0	18.7	17.9	°C/W	
Junction-to-ambient thermal resistance with heat sink	θ_{JA}	E-PBGA	15.3	11.9	10.5	°C/W	
			Resistance Value				
Junction-to-case thermal resistance	θ_{JC}	E-PBGA	8.3			°C/W	
Junction-to-board thermal resistance	θ_{JB}	E-PBGA	14.3			°C/W	

Notes:

1. Case temperature, T_C , is measured at top center of case surface with device soldered to circuit board.
2. $T_A = T_C - P \times \theta_{CA}$, where T_A is ambient temperature and P is power consumption.
3. $T_{CMax} = T_{JMax} - P \times \theta_{JC}$, where T_{JMax} is maximum junction temperature (+125°C) and P is power consumption.
4. The preceding equations assume that the chip is mounted on a board with at least one signal and two power planes.
5. Values in the table were achieved with a JEDEC standard board: 114.5mm x 101.6mm x 1.6mm, 4 layers.
6. Values for an attached heat sink were achieved with a 35mm x 35mm x 15mm unit (see Heat Sink below), attached with a 0.1mm thickness of adhesive having a thermal conductivity of 1.3W/mK.

Heat Sink

The following heat sinks were used in the above thermal analysis:

ALPHA W35-15W (35mm x 35mm x15mm)

ALPHA LPD35-15B (35mm x 35mm x15mm)

The heat sinks are manufactured by:

Alpha Novatech, Inc. (www.alphanovatech.com)

473 Sapena Court, #12

Santa Clara, CA 95054

Phone: 408-567-8082

Clocking Specifications

Table 16. Clocking Specifications

Symbol	Parameter	Min	Max	Units	Notes
SysClk Input					
F_C	Frequency	33.33	66.66	MHz	1
T_C	Period	15	30	ns	
T_{CS}	Edge stability (cycle-to-cycle jitter)	–	± 0.15	ns	2
T_{CH}	High time	40% of nominal period	60% of nominal period	ns	
T_{CL}	Low time	40% of nominal period	60% of nominal period	ns	
Note: Input rising and falling edge slew rate $\geq 1V/ns$					3
CPU Clock					
F_C	Frequency	333	667		
MemClkOut and PLB Clock					
F_C	Frequency	100	133.33	MHz	
T_C	Period	7.5	10	ns	
T_{CH}	High time	45% of nominal period	55% of nominal period	ns	
PLL VCO					
F_C	Frequency	600	1334	MHz	
T_C	Period	0.7496	1.66	ns	
TrcClk					
F_C	Frequency	CPU $F_C/4$	CPU $F_C/4$		
MAL Clock					
F_C	Frequency	45	83.33	MHz	
T_C	Period	12	22.2	ns	

Notes:

1. SysClk supports spread spectrum clocking with a -1% down-spread and a 40 kHz or less modulation frequency. For a 33.33MHz minimum SysClk, the modulation frequency range of 33.00 MHz to 33.33 MHz is supported.
2. The maximum input cycle-to-cycle jitter is ± 100 ps within the frequency range 100 kHz to 20 MHz. Outside the frequency range of 100 kHz to 20 MHz, the maximum input cycle-to-cycle jitter is ± 150 ps.
3. Slew rate is measured between 0.7V and 1.7V.

Data Sheet

Figure 5. Timing Waveform

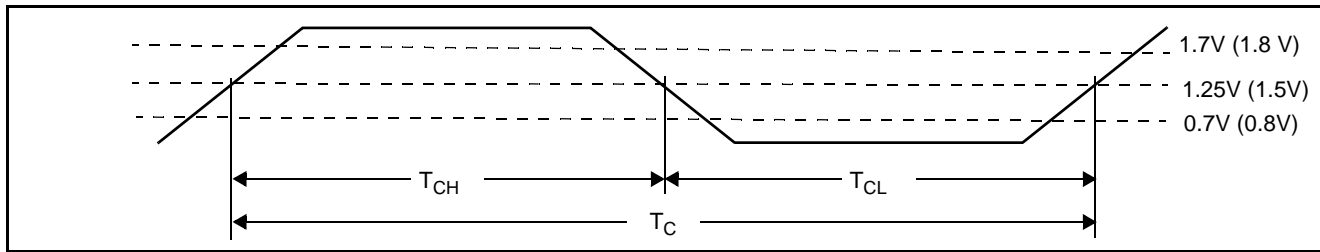

Note: SysClk is a 2.5V/3.3V tolerant receiver. Slew rate should be measured between 0.7V and 1.7V.

Spread Spectrum Clocking

Care must be taken when using a spread spectrum clock generator (SSCG) with the PPC440EP. This controller uses a PLL for clock generation inside the chip. The accuracy with which the PLL follows the SSCG is referred to as tracking skew. The PLL bandwidth and phase angle determine how much tracking skew there is between the SSCG and the PLL for a given frequency deviation and modulation frequency. When using an SSCG with the PPC440EP the following conditions must be met:

- The frequency deviation must not violate the minimum clock cycle time. Therefore, when operating the PPC440EP with one or more internal clocks at their maximum supported frequency, the SSCG can only lower the frequency.
- The maximum frequency deviation of SysClk cannot exceed -1% , and the modulation frequency cannot exceed 40kHz. In some cases, on-board PPC440EP peripherals impose more stringent requirements.

Notes:

1. The serial port baud rates are synchronous to the modulated clock. The serial port has a tolerance of approximately 1.5% on baud rate before framing errors begin to occur. The 1.5% tolerance assumes that the connected device is running at precise baud rates.
2. Ethernet operation is unaffected.
3. IIC operation is unaffected.

Important: It is up to the system designer to ensure that any SSCG used with the PPC440EP meets the above requirements and does not adversely affect other aspects of the system.

I/O Specifications

Table 17. Peripheral Interface Clock Timings

Parameter	Min	Max	Units	Notes
PCIClk input frequency (asynchronous mode)	–	66.66	MHz	
PCIClk period (asynchronous mode)	15	–	ns	
PCIClk input high time	40% of nominal period	60% of nominal period	ns	
PCIClk input low time	40% of nominal period	60% of nominal period	ns	
EMCMDClk output frequency	–	2.5	MHz	
EMCMDClk period	400	–	ns	
EMCMDClk output high time	160	–	ns	
EMCMDClk output low time	160	–	ns	
EMCTxClk input frequency MII	2.5	25	MHz	
EMCTxClk period MII	40	400	ns	
EMCTxClk input high time	35% of nominal period	–	ns	
EMCTxClk input low time	35% of nominal period	–	ns	
EMCRxClk input frequency MII	2.5	25	MHz	
EMCRxClk period MII	40	400	ns	
EMCRxClk input high time	35% of nominal period	–	ns	
EMCRxClk input low time	35% of nominal period	–	ns	
EMCRefClk input frequency RMII (SMII)	50 (125)	50 (125)	MHz	2
EMCRefClk period RMII (SMII)	20 (8)	20 (8)	ns	
EMCRefClk input high time	35% of nominal period	65% of nominal period	ns	
EMCRefClk input low time	35% of nominal period	65% of nominal period	ns	
PerClk (and OPB clock) output frequency (for ext. master or sync. slaves)	33.33	66.66	MHz	
PerClk period	15	30	ns	
PerClk output high time	50% of nominal period	66% of nominal period	ns	
PerClk output low time	33% of nominal period	50% of nominal period	ns	
UARTSerClk input frequency	–	$1000 / (2T_{OPB} + 2ns)$	MHz	1
UARTSerClk period	$2T_{OPB} + 2$	–	ns	1
UARTSerClk input high time	$T_{OPB} + 1$	–	ns	1
UARTSerClk input low time	$T_{OPB} + 1$	–	ns	1
USB2Clk input frequency	60	60	MHz	
USB1Clk input frequency	48	48	MHz	

Data Sheet

Table 17. Peripheral Interface Clock Timings (Continued)

Parameter	Min	Max	Units	Notes
TmrClk input frequency	–	100	MHz	
TmrClk period	10	–	ns	
TmrClk input high time	40% of nominal period	60% of nominal period	ns	
TmrClk input low time	40% of nominal period	60% of nominal period	ns	

Notes:

1. T_{OPB} is the period in ns of the OPB clock. The internal OPB clock runs at 1/2 the frequency of the PLB clock. The maximum OPB clock frequency is 66.66 MHz.
2. In RMI1 mode, a 50MHz +/- 50PPM input EMCTRefClk is required. In SM11 mode, a 125 MHz +/- 100PPM input EMCTRefClk is required.

Figure 6. Input Setup and Hold Waveform

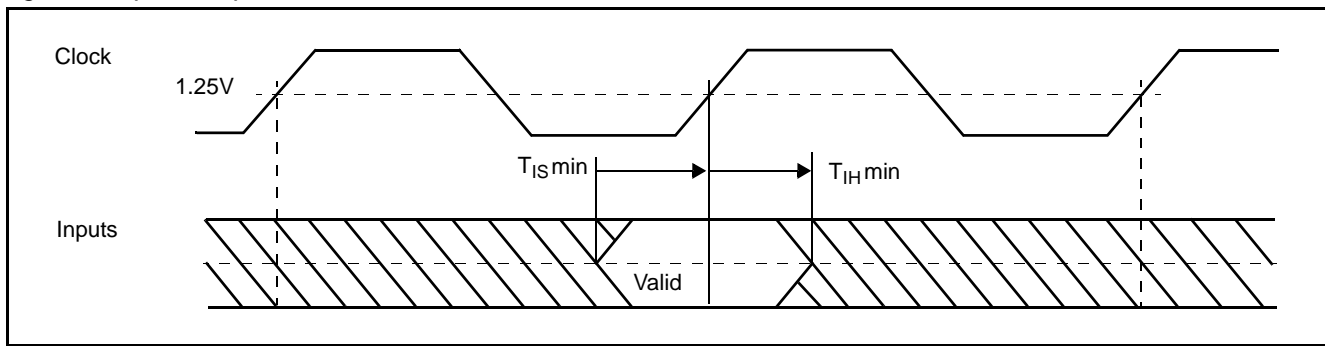

Figure 7. Output Delay and Float Timing Waveform

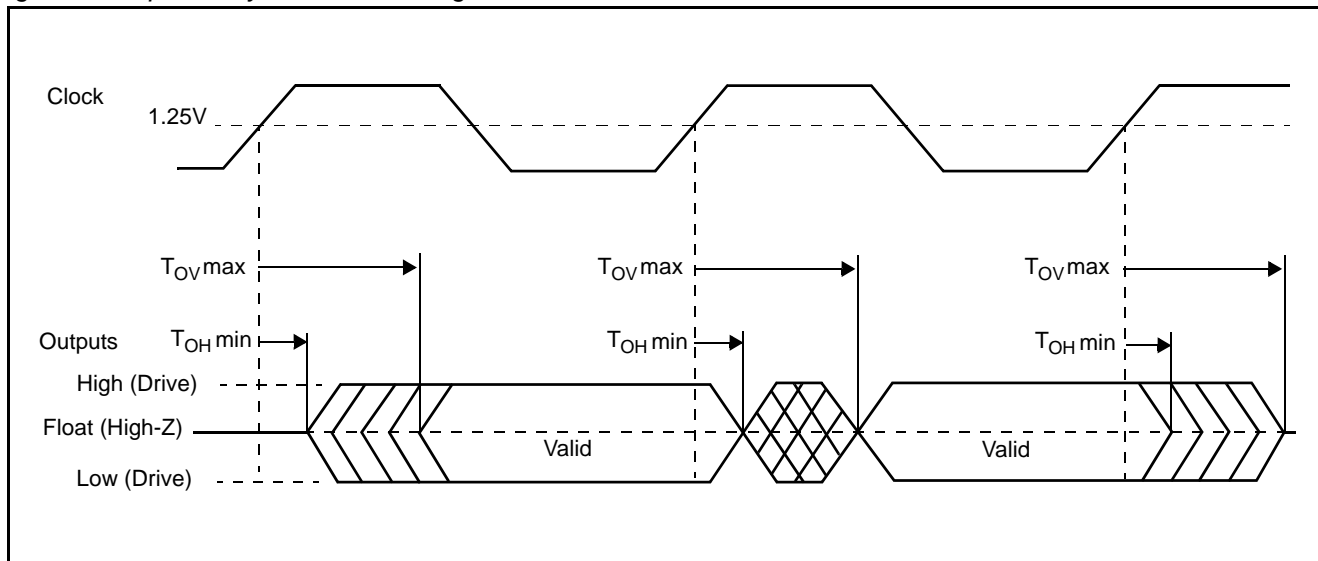

Table 18. I/O Specifications—PCI, USB, UART, IIC, SPI, Ethernet, System and Debug Interfaces (Sheet 1 of 3)

Notes:

1. Ethernet interface meets timing requirements as defined by IEEE 802.3 standard.
2. EMCSync is a weak driver. Redrive EMCSync when driving more than one load.

Signal	Input (ns)		Output (ns)		Output Current (mA)		Clock	Notes
	Setup Time (T _{IS} min)	Hold Time (T _{IH} min)	Valid Delay (T _{OV} max)	Hold Time (T _{OH} min)	I/O H (minimum)	I/O L (minimum)		
PCI Interface								
PCIA031:00	5	0	6	2	0.5	1.5	PCIClk	
PCIC3:0/BE3:0	5	0	6	2	0.5	1.5	PCIClk	
PCIDevSel	5	0	6	2	0.5	1.5	PCIClk	
PCIFrame	5	0	6	2	0.5	1.5	PCIClk	
PCIGnt0:5			6	2	0.5	1.5	PCIClk	
PCIIDSel	5	0			n/a	n/a	PCIClk	
PCIINT			6	2	0.5	1.5	PCIClk	async
PCIIRDY	5	0	6	2	0.5	1.5	PCIClk	
PCIPar	5	0	6	2	0.5	1.5	PCIClk	
PCIPErr	5	0	6	2	0.5	1.5	PCIClk	
PCIReq0:5	5	0			n/a	n/a	PCIClk	
PCIReset					n/a	n/a	PCIClk	
PCISErr	5	0	6	2	0.5	1.5	PCIClk	
PCIStop	5	0	6	2	0.5	1.5	PCIClk	
PCITRDY	5	0	6	2	0.5	1.5	PCIClk	
Ethernet MII Interface								
EMCCD	10	10			5.1	6.8		1, async
EMCCrS	10	10			5.1	6.8		1, async
EMCDV	10	10			5.1	6.8		
EMCMDClk					5.1	6.8		1, async
EMCMDIO					5.1	6.8	EMCMDClk	1
EMCRxClk					5.1	6.8		1, async
EMCRxD0:3	10	10			5.1	6.8	EMCRxClk	1
EMCRxErr	10	10			5.1	6.8	EMCRxClk	1
EMCTxClk					n/a	n/a		1, async
EMCTxD0:3			20	0	5.1	6.8	EMCTxClk	1
EMCTxEn			20	0	5.1	6.8	EMCTxClk	1
EMCTxErr			20	0	5.1	6.8	EMCTxClk	1
RejectPkt	3	1					EMCRxClk	for MII, RMII, SMII
Ethernet RMII Interface								
EMC0CRSDV	4	2						
EMC0RxD0:1	4	2			5.1	6.8	EMCRefClk	
EMC0RxErr	4	2			5.1	6.8	EMCRefClk	
EMC0Tx0:1			12.5	2	5.1	6.8	EMCRefClk	
EMC1CRSDV	4	2						
EMC1RxD0:1	4	2			5.1	6.8	EMCRefClk	
EMC1RxErr	4	2			5.1	6.8	EMCRefClk	
EMC1Tx0:1			12.5	2	5.1	6.8	EMCRefClk	

Data Sheet

Table 18. I/O Specifications—PCI, USB, UART, IIC, SPI, Ethernet, System and Debug Interfaces (Sheet 2 of 3)

Notes:

1. Ethernet interface meets timing requirements as defined by IEEE 802.3 standard.
2. EMCSync is a weak driver. Redrive EMCSync when driving more than one load.

Signal	Input (ns)		Output (ns)		Output Current (mA)		Clock	Notes
	Setup Time (T _{IS} min)	Hold Time (T _{IH} min)	Valid Delay (T _{OV} max)	Hold Time (T _{OH} min)	I/O H (minimum)	I/O L (minimum)		
Ethernet SMII Interface								
EMC0RxD	1.5	1			5.1	6.8	EMCRefClk	
EMC0TxD			3.5	0	5.1	6.8	EMCRefClk	
EMC1RxD	1.5	1			5.1	6.8	EMCRefClk	
EMC1TxD			3.5	0	5.1	6.8	EMCRefClk	
EMCSync			3.5	0	5.1	6.8	EMCRefClk	2
Internal Peripheral Interface								
IIC0SClk					n/a	10.2	IIC0Clk	
IIC0SData			5	0	n/a	10.2		
IIC1SClk					n/a	10.2		
IIC0SData		0	5		n/a	10.2	IIC0Clk	
SCPClkOut	7	2		0	n/a	10.2		
SCPDI	7	2			n/a	10.2	SCPClkOut	
SCPDO			6	0	n/a	10.2	SCPClkOut	
UARTn_Rx					n/a	n/a		async
UARTn_Tx					10.3	7.1		async
UARTn_DCD					n/a	n/a		async
UARTn_DSR					n/a	n/a		async
UARTn_CTS					na	na		async
UARTn_DTR					10.3	7.1		async
UARTn_RI					n/a	n/a		async
UARTn_RTS					10.3	7.1		async
USB1DevXcvr			3	0	USB 1.1	USB 1.1	USB1Clk	
USB1DevXcvr			3	0	USB 1.1	USB 1.1	USB1Clk	
USB1HostXcvr			3	0	USB 1.1	USB 1.1	USB1Clk	
USB1HostXcvr			3	0	USB 1.1	USB 1.1	USB1Clk	
USB2DI0:7	7	0.05			n/a	n/a	USB2Clk	
USB2DO0:7			3	0	5.1	6.8	USB2Clk	
USB2LS0:1	5.2	0.02			n/a	n/a	USB2Clk	
USB2OM0:1			3	0	7.1	9.6	USB2Clk	
USB2RxAct	7	0.05			n/a	n/a	USB2Clk	
USB2RxDV			3	0	7.1	9.6	USB2Clk	
USB2RxErr			3	0	7.1	9.6		
USB2Susp			3	0	7.1	9.6		
USB2TermSel			3	0	7.1	9.6		
USB2TxRdy	6	0.1			n/a	n/a		
USB2TxVal			3	0	7.1	9.6		
USB2XcvrSel			3	0	7.1	9.6		
Interrupts Interface								
IRQ0:9					n/a	n/a		async

Table 18. I/O Specifications—PCI, USB, UART, IIC, SPI, Ethernet, System and Debug Interfaces (Sheet 3 of 3)

Notes:

1. Ethernet interface meets timing requirements as defined by IEEE 802.3 standard.
2. EMCSync is a weak driver. Redrive EMCSync when driving more than one load.

Signal	Input (ns)		Output (ns)		Output Current (mA)		Clock	Notes
	Setup Time (T _{IS} min)	Hold Time (T _{IH} min)	Valid Delay (T _{OV} max)	Hold Time (T _{OH} min)	I/O H (minimum)	I/O L (minimum)		
JTAG Interface								
TCK					n/a	n/a		async
TDI					n/a	n/a		async
TDO					15.3	10.2		async
TMS					n/a	n/a		async
TRST					n/a	n/a		async
System Interface								
SysReset					n/a	n/a		async
Halt					n/a	n/a		async
SysErr					10.3	7.1		async
GPIO00:63					10.3	7.1		
Trace Interface								
TrcClk					10.3	7.1		
TrcBS0:2					10.3	7.1	TrcBS0:2	
TrcES0:4					10.3	7.1	TrcES0:4	
TrcTS0:6					10.3	7.1	TrcTS0:6	

Data Sheet

Table 19. I/O Specifications—EBC, EBMI, DMA and NAND Flash Interfaces

Notes:

1. PerClk rising edge at package pin with a 10pF load trails the internal PLB clock by approximately 1.3ns.

Signal	Input (ns)		Output (ns)		Output Current (mA)		Clock	Notes
	Setup Time (T _{IS} min)	Hold Time (T _{IH} min)	Valid Delay (T _{OV} max)	Hold Time (T _{OH} min)	I/O H (minimum)	I/O L (minimum)		
External Slave Peripheral Interface								
DMAAck0:1			10	1	5.1	6.8	PerClk	
DMAAck2:3			10	1	15.3	10.2	PerClk	
DMAReq0:3	11.7	0.5			na	na	PerClk	
EOT0:1/TC0:1	11.7	0.5	10	1	5.1	6.8	PerClk	
EOT2:3/TC2:3	11.7	0.5	10	1	15.3	10.2	PerClk	
PerAddr02:31	4	1	7.2	1.5	15.3	10.2	PerClk	
PerBLast	4	1	6.5	1.5	15.3	10.2	PerClk	
PerCS0:5			6.5	1.5	10.3	7.1	PerClk	
PerData00:15	4	1	7.2	1.5	15.3	10.2	PerClk	
PerOE			6.5	1.5	15.3	10.2	PerClk	
PerReady	6	1			15.3	10.2	PerClk	
PerR/W	4	1	6.5	1.5	15.3	10.2	PerClk	
PerWBE0:1	4	1	6.5	1.5	15.3	10.2	PerClk	
External Master Peripheral Interface								
BusReq			6.5	1.5	7.1	9.6	PerClk	
ExtAck			6.5	1.5	7.1	9.6	PerClk	
ExtReq	4	1			n/a	n/a	PerClk	
ExtReset			6.0	1.5	15.3	10.2	PerClk	
HoldAck			6.5	1.5	7.1	9.6	PerClk	
HoldReq	4	1			na	na	PerClk	
HoldPri	4	1			na	na	HoldPri	
PerClk					15.3	10.2	PLB Clk	1
PerErr	6	1			10.3	7.1	PerClk	
NAND Flash Interface								
NFALE			6.5	1.5	5.1	6.8	Perclk	
NFCE0:3			6.5	1.5	10.3	7.1	Perclk	
NFCLE			6.5	1.5	5.1	6.8	Perclk	
NFRdyBusy	4	1			na	na	Perclk	
NFREn			6.5	1.5	5.1	6.8	Perclk	
NFWEn			6.5	1.5	5.1	6.8	Perclk	

Table 20. Input Capacitance

Parameter	Symbol	Maximum	Unit	Notes
Group 1 (2.5V SSTL I/O)	C _{IN1}	2.5	pF	
Group 2 (3.3V LVTTTL I/O)	C _{IN2}	2.1	pF	
Group 3 (PCI I/O)	C _{IN3}	2.5	pF	
Group 4 (Receivers)	C _{IN4}	0.9	pF	
Group 5 (3.3V tolerant CMOS I/O)	C _{IN5}	2.4	pF	
Group 6 (USB)	C _{IN6}	4.5	pF	

Test Conditions

Clock timing and switching characteristics are specified in accordance with operating conditions shown in the table "Recommended DC Operating Conditions." AC specifications are characterized with $V_{DD} = 1.5V$, $T_J = +125^\circ C$ and a 50pF test load as shown in the figure to the right.

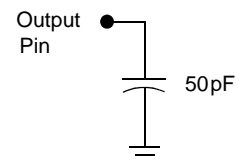

Data Sheet

DDR1 SDRAM I/O Specifications

The DDR1 SDRAM controller times its operation with internal PLB clock signals and generates MemClkOut0 from the PLB clock. The PLB clock is an internal signal that cannot be directly observed. However MemClkOut0 is the same frequency as the PLB clock signal and is in phase with the PLB clock signal.

Note: MemClkOut0 can be advanced with respect to the PLB clock by means of the SDRAM0_CLKTR programming register. In a typical system, users advance MemClkOut by 90°. This depends on the specific application and requires a thorough understanding of the memory system in general (refer to the DDR SDRAM controller chapter in the *PowerPC 440EP User's Manual*).

In the following sections, the label MemClkOut0(0) refers to MemClkOut0 when it has not been phase-shifted, and MemClkOut0(90) refers to MemClkOut0 when it has been phase-advanced 90°. Advancing MemClkOut0 by 90° creates a 3/4 cycle setup time and 1/4 cycle hold time for the address and control signals in relation to MemClkOut0(90). The rising edge of MemClkOut0(90) aligns with the first rising edge of the DQS signal.

The following DDR data is generated by means of simulation and includes logic, driver, package RLC, and lengths. Values are calculated over best case and worst case processes with speed, temperature, and voltage as follows:

Best Case = Fast process, -40°C, +1.6V

Worst Case = Slow process, +85°C, +1.4V

Note: In all the following DDR tables and timing diagrams, *minimum* values are measured under *best* case conditions and *maximum* values are measured under *worst* case conditions.

The signals are terminated as indicated in the figure below for the DDR timing data in the following sections.

Figure 8. DDR SDRAM Simulation Signal Termination Model

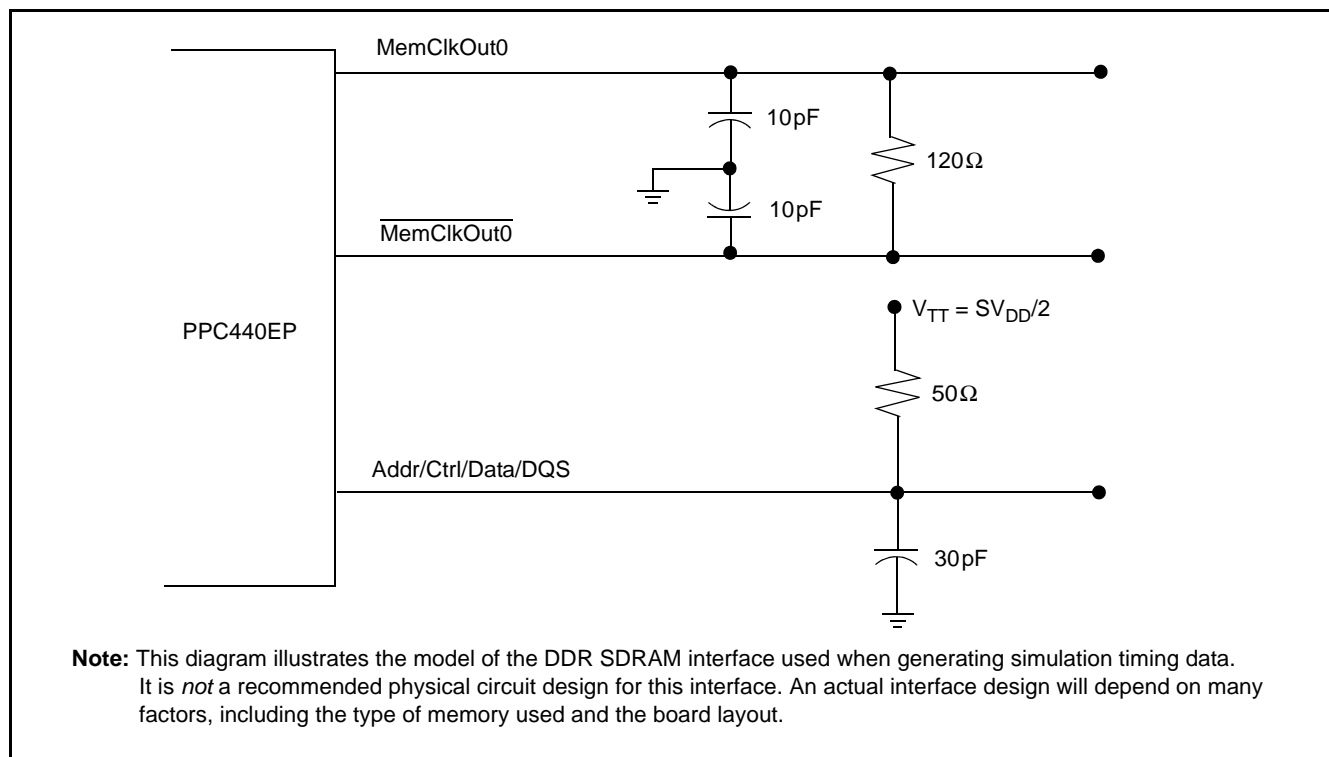

Table 21. DDR SDRAM Output Driver Specifications

Signal Path	Output Current (mA)	
	I/O H (maximum)	I/O L (minimum)
Write Data		
MemData00:07	15.2	15.2
MemData08:15	15.2	15.2
MemData16:23	15.2	15.2
MemData24:31	15.2	15.2
ECC0:7	15.2	15.2
DM0:8	15.2	15.2
MemClkOut0	15.2	15.2
MemAddr00:12	15.2	15.2
BA0:1	15.2	15.2
RAS	15.2	15.2
CAS	15.2	15.2
WE	15.2	15.2
BankSel0:3	15.2	15.2
ClkEn0:3	15.2	15.2
DQS0:8	15.2	15.2

Data Sheet

DDR SDRAM Write Operation

The following diagram illustrates the relationship among the signals involved with a DDR write operation.

Figure 9. DDR SDRAM Write Cycle Timing

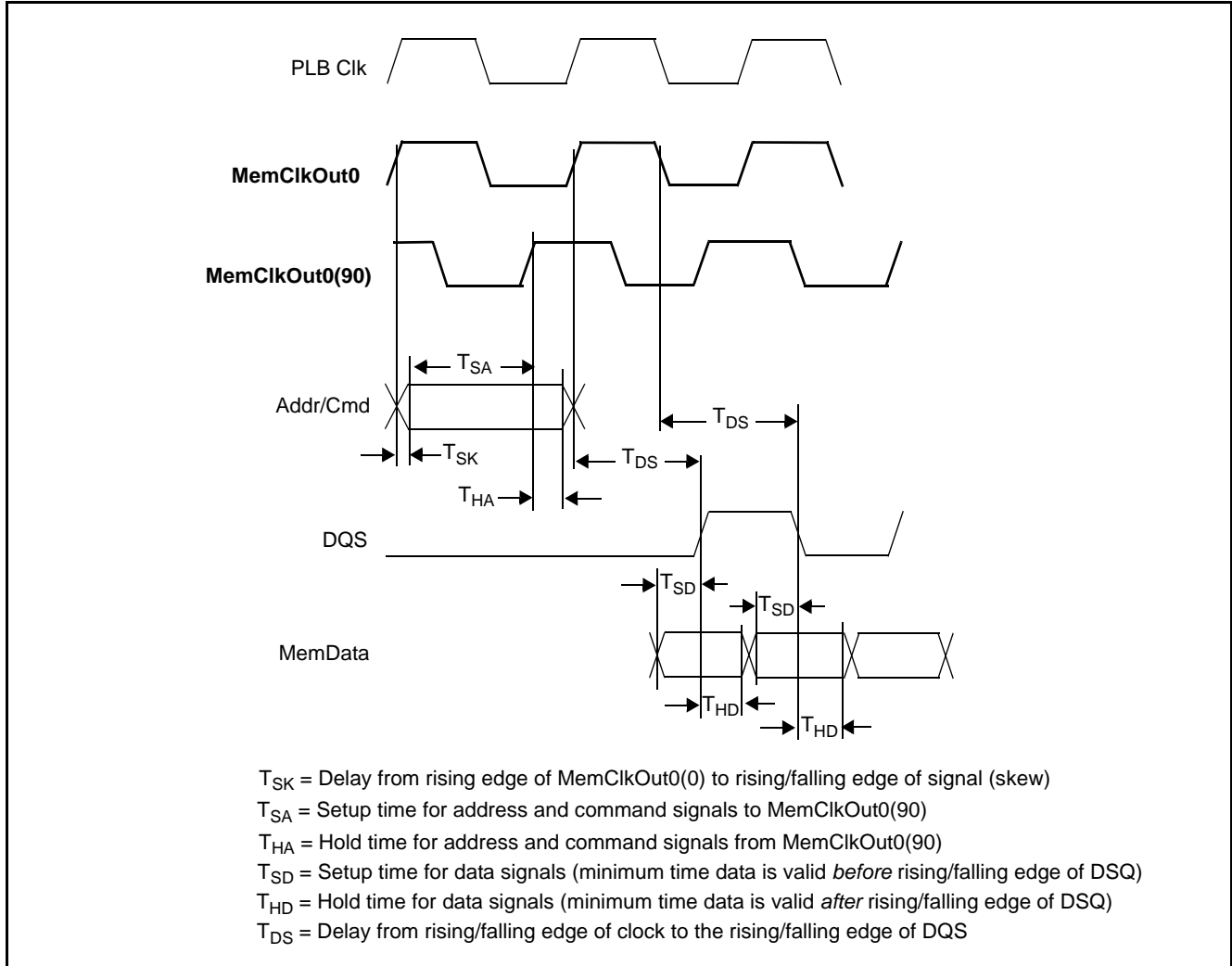

Note: The timing data in the following tables is based on simulation runs using Einstimer.

Table 22. I/O Timing—DDR SDRAM T_{DS}

Notes:

1. All of the DQS signals are referenced to MemClkOut0(0).
2. Clock speed is 133MHz.
3. The T_{DS} values in the table include 3/4 of a cycle at 133MHz ($7.5\text{ns} \times 0.75 = 5.625\text{ ns}$).
4. To obtain adjusted values for lower clock frequencies, subtract 5.625 ns from the values in the table and add 3/4 of the cycle time for the lower clock frequency ($T_{DS} - 5.625 + 0.75T_{CYC}$).

Signal Name	T_{DS} (ns)	
	Minimum	Maximum
DQS0	5.76	5.86
DQS1	5.78	5.91
DQS2	5.82	5.90
DQS3	5.79	5.89
DQS8	5.75	5.88

Table 23. I/O Timing—DDR SDRAM T_{SK} , T_{SA} , and T_{HA}

Notes:

1. Clock speed is 133MHz. T_{SK} is referenced to MemClkOut0(0). T_{SA} and T_{HA} are referenced to MemClkOut0(90).
2. To obtain adjusted T_{SA} values for lower clock frequencies, use 3/4 of the cycle time for the lower clock frequency and subtract T_{SK} maximum ($0.75T_{CYC} - T_{SKmax}$).
3. To obtain adjusted T_{HA} values for lower clock frequencies, use 1/4 of the cycle time for the lower clock frequency and add T_{SK} minimum ($0.25T_{CYC} + T_{SKmin}$).

Signal Name	T_{SK} (ns)		T_{SA} (ns)	T_{HA} (ns)
	Minimum	Maximum	Minimum	Minimum
MemAddr00:12	0.11	0.32	5.31	1.99
BA0:1	0.07	0.31	5.32	1.95
BankSel0:3	0.05	0.25	5.38	1.93
ClkEn0:3	0.07	0.28	5.35	1.95
CAS	0.05	0.31	5.32	1.93
RAS	0.05	0.28	5.35	1.93
WE	0.08	0.22	5.41	1.96

Table 24. I/O Timing—DDR SDRAM T_{SD} and T_{HD}

Notes:

1. T_{SD} and T_{HD} are measured under worst case conditions.
2. Clock speed for the values in the table is 133MHz.
3. The time values in the table include 1/4 of a cycle at 133MHz ($7.5\text{ns} \times 0.25 = 1.875\text{ ns}$).
4. To obtain adjusted T_{SD} and T_{HD} values for lower clock frequencies, subtract 1.875 ns from the values in the table and add 1/4 of the cycle time for the lower clock frequency (e.g., $T_{SD} - 1.875 + 0.25T_{CYC}$).

Signal Names	Reference Signal	T_{SD} (ns)	T_{HD} (ns)
MemData00:07, DM0	DQS0	1.795	1.866
MemData08:15, DM1	DQS1	1.775	1.865
MemData16:23, DM2	DQS2	1.745	1.862
MemData24:31, DM3	DQS3	1.765	1.864
ECC0:7, DM8	DQS8	1.685	1.857

Data Sheet**DDR SDRAM Read Operation**

The following examples of timing for DDR SDRAM read operations are based on the relationship between the incoming data and the PLB clock signal. Since the PLB clock cannot be directly observed, the delay of MemClkOut(0) relative to the PLB clock (T_{MD}) is provided.

The internal Read Clock signal, like MemClkOut0, is derived from the PLB clock and can be delayed relative to the PLB clock by programming the RDCT and RDCD fields in the SDRAM0_TR1 register. The delay can be programmed from 0 to 1/2 cycle in steps using RDCT. Setting RDCD results in a 1/2 cycle delay plus the value set in RDCT. The delay of Read Clock relative to the PLB clock (T_{RD}) shown below assumes the programmable Read Clock delay is set to zero.

Figure 10. DDR SDRAM MemClkOut0 and Read Clock Delay

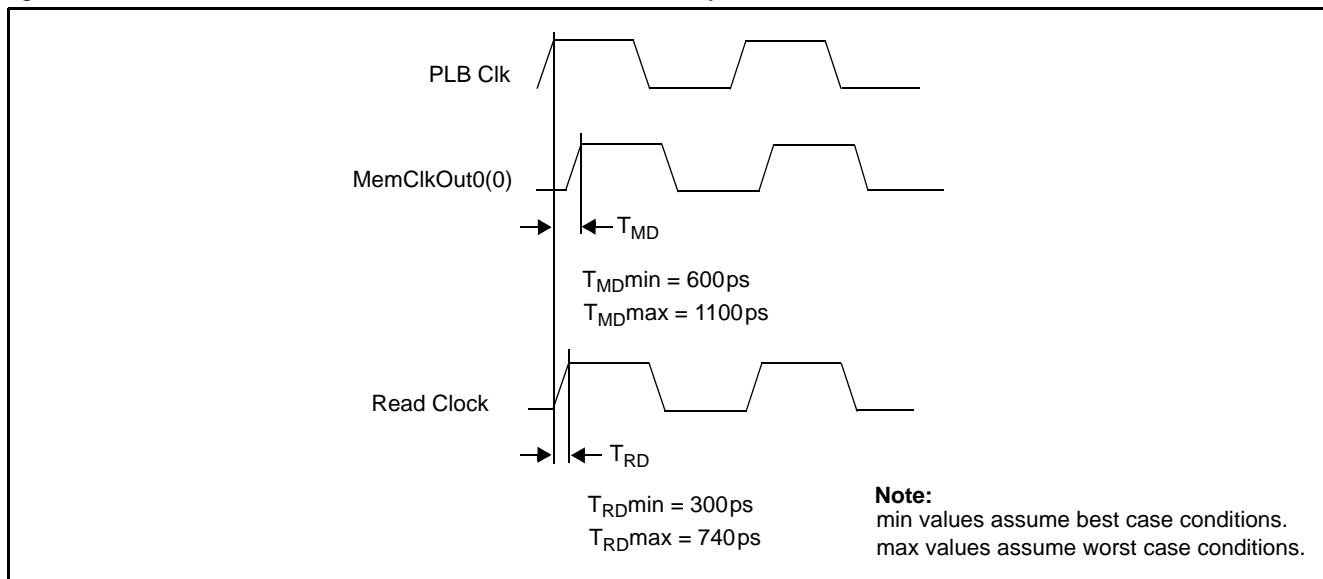

In operation, following the receipt of an address and read command from the PPC440EP, the SDRAM generates data and the DQS signals coincident with MemClkOut0. The data is latched into the PPC440EP using a DQS signal that is delayed 1/4 of a cycle. In order to accommodate timing variations introduced by the system designs using this chip, the three-stage data path shown below is used to eliminate metastability and allow data sampling to be adjusted for minimum latency. This adjustment requires programming the Read Clock delay and the selection of Stage 1, Stage 2, or Stage 3 data for sampling at Read Sample Point flipflop (RDSP).

Figure 11. DDR SDRAM Read Data Path

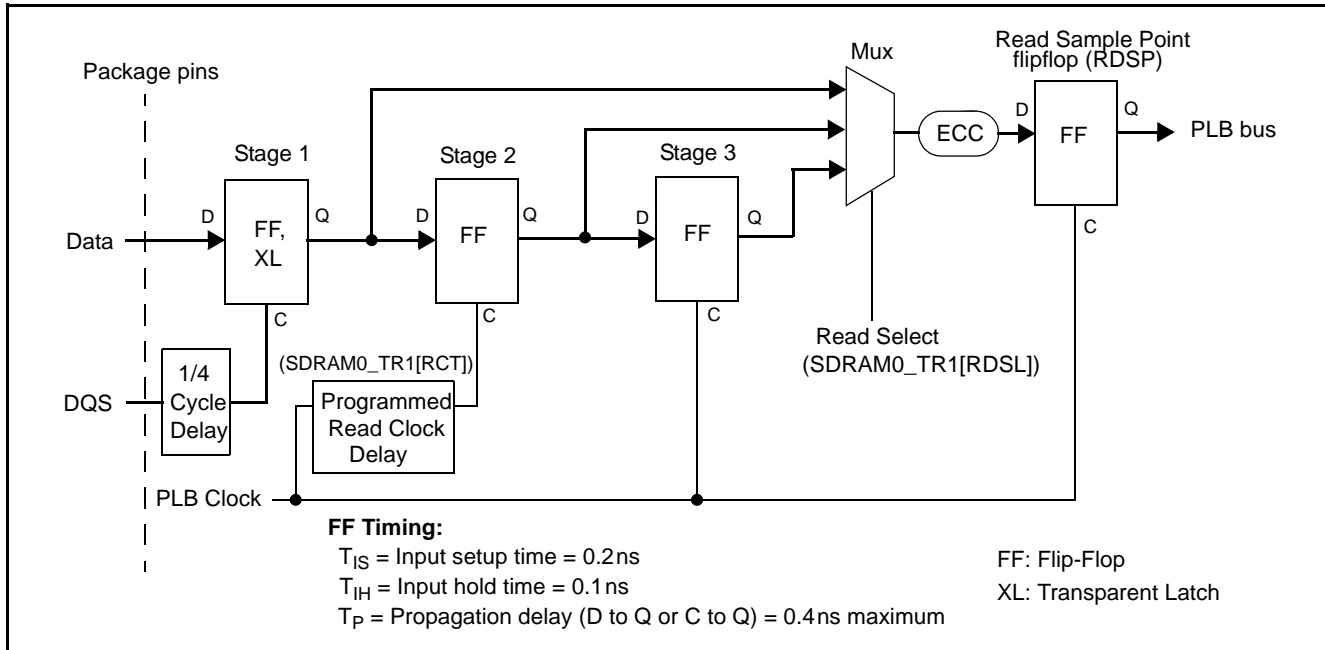

Table 25. I/O Timing—DDR SDRAM T_{SIN} and T_{DIN}

Notes:

1. T_{SIN} = Delay from DQS at package pin to C on Stage 1 FF.
2. T_{DIN} = Delay from data at package pin to D on Stage 1 FF.
3. Clock speed for the values in the table is 133MHz.
4. The time values for T_{SIN} include 1/4 of a cycle at 133MHz (7.5ns x 0.25 = 1.875 ns).

Signal Name	T_{SIN} (ns) minimum	T_{SIN} (ns) maximum	Signal Name	T_{DIN} (ns) minimum	T_{DIN} (ns) maximum
DQS0	2.74	3.70	MemData00:07	0.86	1.87
DQS1	2.75	3.69	MemData08:15	0.87	1.86
DQS2	2.74	3.69	MemData16:23	0.89	1.86
DQS3	2.76	3.69	MemData24:31	0.88	1.85
DQS8	2.77	3.68	ECC0:7	0.89	1.83

In the following examples, the data strobes (DQS) and the data are shown to be coincident. There is actually a slight skew as specified by the SDRAM specifications, and there can be additional skew due to loading and signal routing. It is recommended that the signal length for all of the eight DQS signals be matched.

Data Sheet

Example 1:

If the data-to-PLB clock timing is as shown in the example below, then the read clock is not delayed and the Stage 1 data is sampled at **(1)**. Except for small, low frequency memory systems with the memory located physically close to the PPC440EP, it is unlikely that Stage 1 data can be sampled. When the data comes later, it is necessary to sample Stage 2 or Stage 3 data. (see Examples 2 and 3). Another way to get the desired data-to-PLB timing to allow Stage 1 sampling is to buffer MemClkOut0 and skew it enough to guarantee the timing. In this example, T_T is system dependent and taken into account by controller initialization software.

Figure 12. DDR SDRAM Read Cycle Timing—Example 1

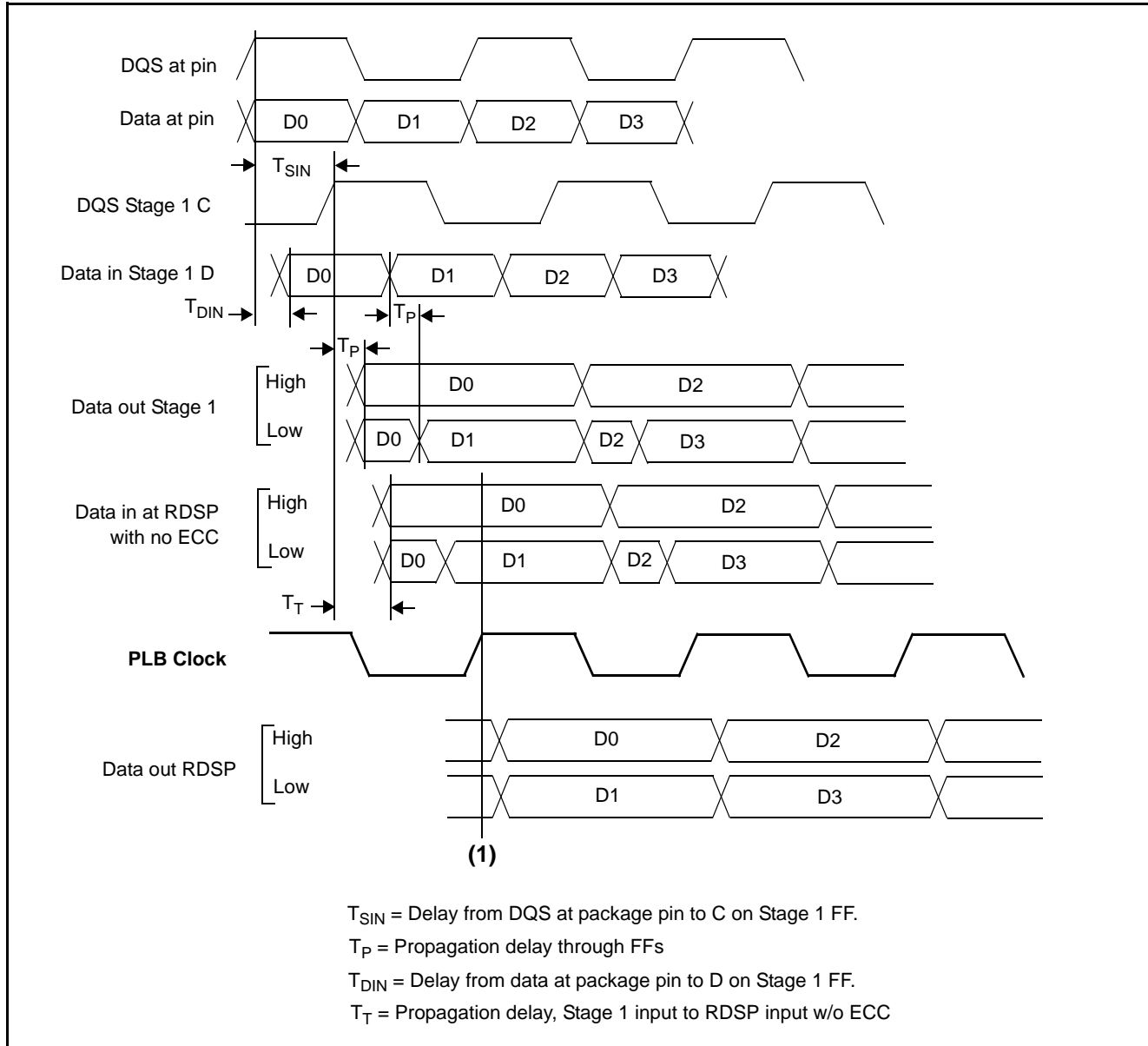

Example 2:

In this example Read Clock is delayed almost 1/2 cycle. Without ECC, Stage 2 data can be sampled at **(2)**. If ECC is enabled, Stage 3 data must be sampled (see Example 3). In this example, T_T and T_{TE} are system dependent and taken into account by controller initialization software.

Figure 13. DDR SDRAM Read Cycle Timing—Example 2

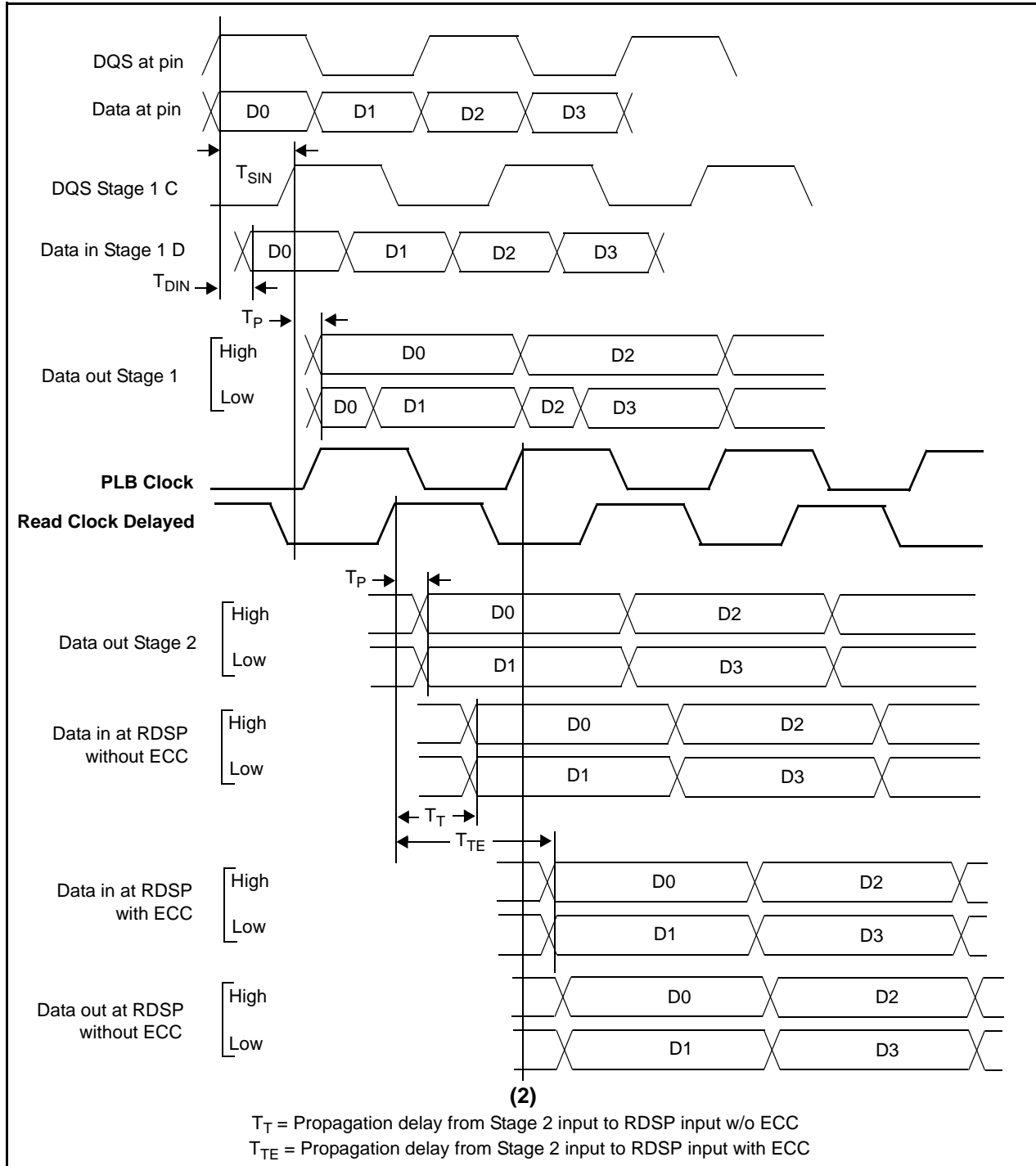

Data Sheet

Example 3:

In this example, ECC is enabled. This requires that Stage 3 data be sampled at **(3)**. If ECC is disabled, the system will still work, but there will be more latency before the data is sampled into RDSP. In this example, T_T and T_{TE} are system dependent and taken into account by controller initialization software.

Figure 14. DDR SDRAM Read Cycle Timing—Example 3

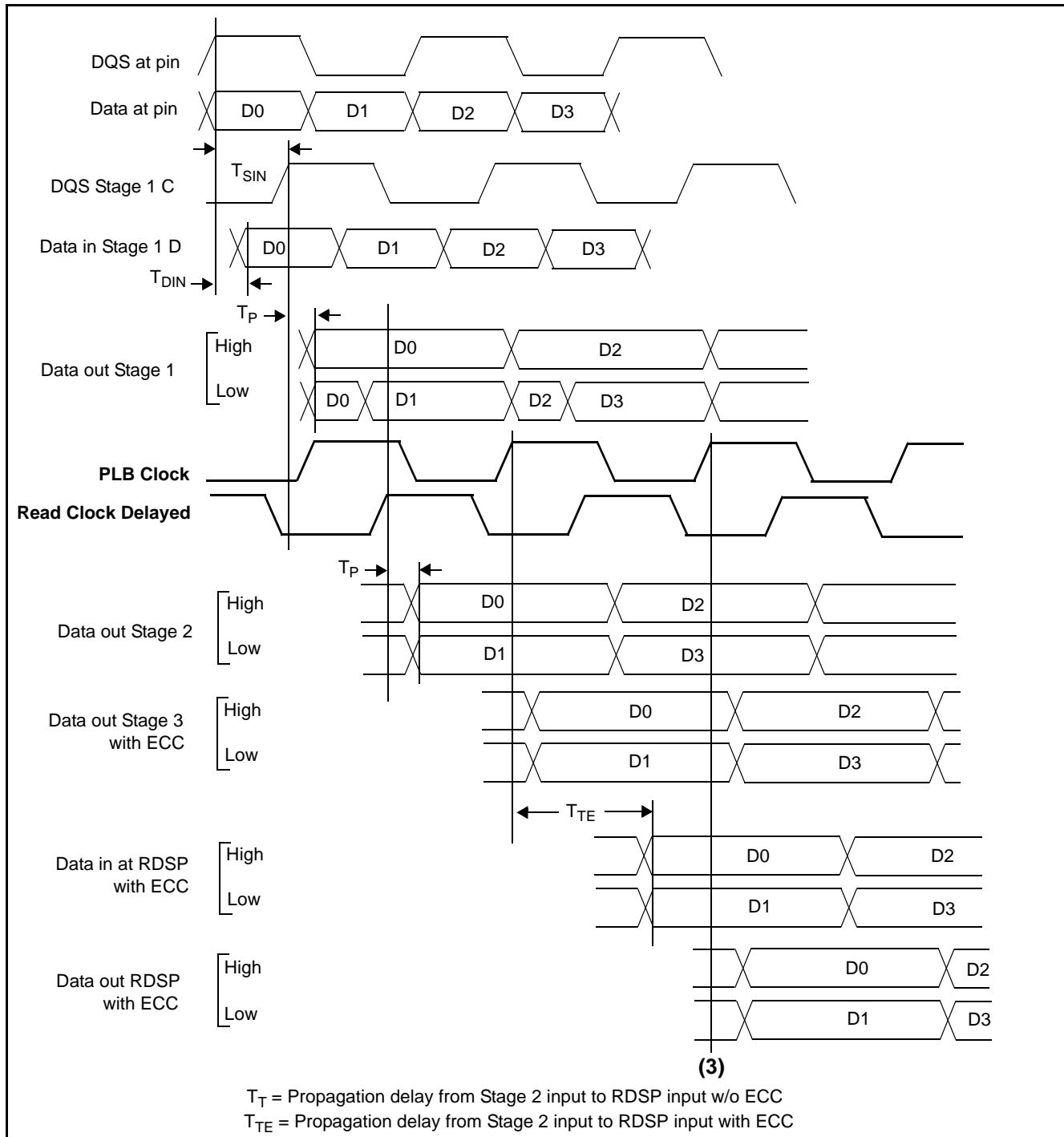

Boot Configuration

The PPC440EP has several configurable boot parameters that must be initialized prior to booting. These parameters are configured by one of several default boot options or programmed by data read from an IIC serial EEPROM (see “Serial EEPROM” below). Strap signals sampled during reset select which method is used to initialize the boot parameters (see “Strapping” below).

Strapping

The Bootstrap Controller selects the boot options based on the state of the strap signals during reset. The strap signals are sampled on the rising edge of SysClk while SysReset is driven low. They must not change state until after SysReset is driven high in order to guarantee the correct boot option is selected.

These pins are used for strap functions only during reset. Following reset, they are used as UART signals. The UART signal names are shown in parentheses following the pin number.

The following table lists the strapping pins along with their functions and boot strap options:

Table 26. Strapping Pin Assignments

Function	Option	Ball Strapping		
		R25 (UART0_DCD)	U26 (UART0_DSR)	V26 (UART0_CTS)
Serial device is disabled. Each of the six options (A–F) is a combination of boot source, boot-source width, and clock frequency specifications. Refer to the IIC Bootstrap Controller chapter in the <i>PPC440EP Embedded Processor User's Manual</i> for details.	A	0	0	0
	B	0	0	1
	C	0	1	0
	D	0	1	1
	E	1	0	0
	F	1	1	0
Serial device is enabled. Boot Option G and H enable the Bootstrap Controller to program boot parameters using data read from an IIC serial EEPROM. Option G and H support different IIC addresses. Option G - Address 0xA8 is left justified (0x1010100 + R/W bit). Option H - Address 0xA4 is left justified (0x1010010 + R/W bit). Note: If reading of configuration data from the serial device fails, the PPC440EP defaults to configuration X.	G (0xA8)	1	0	1
	H (0xA4)	1	1	1

Serial EEPROM

Boot Options G and H enable the Bootstrap Controller to read 16 bytes of configuration data from a serial EEPROM attached to the IIC0 bus after SysReset deasserts. The Bootstrap Controller stores the data in the SDR0_SDSTP0:3 registers.

Note: The IIC serial EEPROM must have a one-byte offset address. Multi-byte offset addresses are not supported.

The initialization settings and their default values are covered in detail in the *PowerPC 440EP User's Manual*.

Data Sheet**Revision Log**

Date	Version	Contents of Modification
08/21/2003		Initial creation of document.
09/22/2003		Misc. updates and corrections.
10/07/2003		Misc. updates and corrections.
10/13/2003		Add I/O timing.
10/31/2003		Miscellaneous updates.
11/03/2003		Correct initialization strapping pins and response IIC interface.
11/25/2003		Correct OV_{DD} and SV_{DD} pin assignments.
12/15/2003		Delete heat sink mounting information placeholders and remove Confidential status.
12/19/2003		Restore Confidential status.
01/12/2004		Update DDR SDRAM interface timing section.
03/15/2004		Correct MemClkOut0 pin assignment. Correct SDRAM PLL voltage. Add Note 6 to UARTn_CTS signal. Correct SDRAM I/O worst case spec temperature. Change 333MHz to 400MHz.
04/7/2004		Correct label on Ethernet transmit signals.
09/2/2004		Convert to AppliedMicro format.
09/8/2004		Modify headers to flip between left and right pages like the footers. Change part numbers to AppliedMicro part numbers. Remove Confidential status, again
09/28/2004		Add USB clock frequency numbers. Number table and figure captions.
10/06/2004		Correct USB block diagram and description. Update formatting and PDF book marking.
10/12/2004		Add missing DDR SDRAM timing data.
10/28/2004		Miscellaneous updates.
11/18/2004		Add RejectPkt signal to pin Y25. Issue 31 Corrected numbering on PCIReq signal. Issue 30 Added notes to USB signals to correctly define required pull-ups and pull-downs. Issue 20 Correct typo on voltage specification for SAV_{DD} in the DC Power Supply Loads table. Issue 9 Misc. typo corrections. Issue 29
11/19/2004		Change bootstrap option numbers to letters and add two options.
11/22/2004		Correct bootstrap pin settings to match new letter designations.
12/17/2004		Add Revision B part numbers for both leaded and lead-free packages and tape-and-reel shipping.
01/18/2005		Add input capacitance values. Update and add missing voltage supply currents.
01/31/2005		Update DDR SDRAM timing.
02/08/2005		Change circuit type info for some system interface signals and move RejectPkt to the Ethernet group.

Date	Version	Contents of Modification
02/15/2005		Miscellaneous updates
03/10/2005		Miscellaneous updates
03/25/2005		Correct I/O timing specs for ExtReq signal.
04/27/2005		USB 2.0 I/O and DDR SDRAM timing updates.
05/24/2005		Add RoHS compliance statement.
06/14/2005		Updates and additions to power and thermal specifications. Add new 667MHz PNs and remove old 466MHz PNs.
07/06/2005		Change maximum NAND Flash to 256MB.
08/08/2005		Change solder ball size specification and add thermally enhanced package specification.
10/05/2005	1.20	Miscellaneous updates
11/18/2005	1.21	Remove metal-layer specification from technology description. Change default configuration when bootstrap IIC read fails from option A to configuration X. Add package nomenclature. Correct MemClkOut duty cycle. Correct and move PerErr signal description from master to slave. Change maximum VCO frequency to 1334MHz.
02/16/2006	1.22	Add revision level 2.1 (C) part number and PVR number.
05/24/2006	1.23	Update power dissipation and add additional temperature data.
07/19/2006	1.24	Correct enable/disable specifications for PCI Gnt/Req signals.
12/18/2006	1.25	Change analog voltage filter circuit inductor part number. Change all multiplexed GPIO signal defaults to the GPIO signals. Change AC12 default from IRQ5 to DMAReq1. Correct descriptions of LeakTest, RcvrInh, ModeCtrl, RefEn, and DrvrInh1:2 signals Remove "Preliminary" status from header.
04/25/2007	1.26	Remove thermally enhanced package.
01/07/2008	1.27	Added Assembly Requirements section on page 17, added Unused I/Os section on page 50, place the analog filter diagram in its own section. Added changes to the Internal Buses, changes to Assembly Requirements, moved diagram from under Device Characteristics to Power Sequencing and added more information, added information to DDR SDRAM Read Data Path Diagram, added information to Test Condition and I/O Specifications diagrams. Changed the technical support telephone and fax number. Changed temperature rating for 333MHz and 400MHz parts on page 4 as per Product Change Notification: 091207-01. Added note for EMCSync signal to I/O Specification table. Added timing references to I/O Specification tables. Corrected setup and hold timing for RejectPK in I/O Specification table. Added definition for RDSP abbreviation to DDR SDRAM Read Data Path figure. Added notes 3 and 4 to Recommended DC Operating Conditions table. Added Overshoot/Undershoot specification. Removed references to PPC440EP Rev B part number since these parts are no longer available for ordering.
03/18/2008	1.28	Replaced 16750 compatible UART to 16550 Replaced NS16750 with NS16550.
05/07/2008	1.29	Deleted incorrect MDIO timing data from table 19.

Data Sheet

Date	Version	Contents of Modification
06/21/2012	1.30	Updated to new logos. Doc Issue 5632: Updated “Boot Configuration”, “Strapping”, and “Serial EEPROM” information on page 86. Doc Issue 5652: Corrected RMI write timing in Table 18. Updated PDF bookmarks. Updated SysErr description in Table 8. Doc Issue 5856: Added notes to Table 16 regarding Spread Spectrum, SysClk jitter, and slew rate. Doc Issue 7101: Corrected the Case Temperatures in Table 10.



Applied Micro Circuits Corporation
215 Moffett Park Drive, Sunnyvale, CA 94089

Phone: (408) 542-8600 — (800) 840-6055 — Fax: (408) 542-8601

<http://www.apm.com>

AppliedMicro reserves the right to make changes to its products, its data sheets, or related documentation, without notice and warrants its products solely pursuant to its terms and conditions of sale, only to substantially comply with the latest available data sheet. Please consult AppliedMicro's Term and Conditions of Sale for its warranties and other terms, conditions and limitations. AppliedMicro may discontinue any semiconductor product or service without notice, and advises its customers to obtain the latest version of relevant information to verify, before placing orders, that the information is current. AppliedMicro does not assume any liability arising out of the application or use of any product or circuit described herein, neither does it convey any license under its patent rights nor the rights of others. AppliedMicro reserves the right to ship devices of higher grade in place of those of lower grade.

APPLIEDMICRO SEMICONDUCTOR PRODUCTS ARE NOT DESIGNED, INTENDED, AUTHORIZED, OR WARRANTED TO BE SUITABLE FOR USE IN LIFE-SUPPORT APPLICATIONS, DEVICES OR SYSTEMS OR OTHER CRITICAL APPLICATIONS.

AppliedMicro and AMCC are Trademarks of Applied Micro Circuits Corporation. PowerPC and the PowerPC logo are registered trademarks of IBM Corporation. Power and the Power logo are registered trademarks of Power.org.

Copyright © 2007 Applied Micro Circuits Corporation.

All Rights Reserved.