

FF-SRS5925 Dual channel Emergency Stop Module

FF-SRS5925

FEATURES

- Complies with EU Directive for machines 98/37/EC, IEC 204, EN 60204, DIN VDE 0113
- Dual channel input
- Output: two NO contacts and one NC contact
- Switching current from 1 mA to 7 A (5 µm gold plated contacts allow low current)
- Automatic start or manual start modes
- Line fault detection and detection of blocked start push button
- Selectable cross fault detection in emergency stop control circuit
- LED indicates power and the status of both internal relays
- Mechanical life up to ten million operations
- Electrical life up to one million operations
- Voltage drop protection
- Removable terminal strips for ease of maintenance
- Slim housing 22,5 mm / 0.89 in width

TYPICAL APPLICATIONS

- Emergency-stop circuits on machines
- Door protection
- Conveyors/transfer lines
- Use with Type 3 or Type 4 Electro-sensitive Protective Equipment for:
 - Point-of operation protection
 - Perimeter/zone guarding protection



The FF-SRS5925 Emergency Stop modules are designed to be used in emergency stop circuits when danger to personnel or machinery is present. This slim housing device has two safety relays with positive-guided contacts to ensure redundancy.

In the **manual start mode**, the module accepts input from the safety device (light curtain, safety mat, safety switches, etc) between S11/S12 and S21/S22 after activation of the push-button between S33 and S34; then, the normally open safety contacts (13/14, 23/24) will close and the normally closed contact (31/32) will open.

In the **automatic start mode**, the module accepts immediate input from the safety device (light curtain, mat, safety switches, etc) between S11/S12 and S21/S22; if S33/S34 are jumpered, the normally open safety contacts (13/14, 23/24) will close and the normally closed contact (31/32) will open.

In either mode, if the safety device is actuated (emergency stop condition occurs), the normally open contact will open immediately and the normally closed contact will close. This emergency stop condition is relayed via the safety contacts of the module to the machine control circuitry to arrest dangerous motion and/or remove power.

Cross fault monitoring must be used when two independent safety inputs are provided to this module to increase the overall safety level of the solution (see typical application examples).

⚠ WARNING

MISUSE OF DOCUMENTATION

- The information presented in this product sheet (or catalogue) is for reference only. DO NOT USE this document as system installation information.
- Complete installation, operation and maintenance information is provided in the instructions supplied with each product.

Failure to comply with these instructions could result in death or serious injury.

FF-SRS5925 Dual channel Emergency Stop Module



FF-SRS5925

SPECIFICATIONS

- Dual channel Emergency Stop circuits

Input	
Nominal voltage	24 Vac/dc (-5 %, +10 %)
Nominal power consumption	Dc: 2 W (approximately)
Nominal frequency	50 to 60 Hz
Start time	Manual START function: 40 ms Automatic START function: 500 ms
Nominal voltage at S11	23 Vdc (provided by control module)
Input current between S11/S12 and S21/S22	40 mA
Minimum voltage at S12	21 Vdc when activated
Cable resistance between S11/S12 and S21/S22	68 Ω (max.)
Output	
Contact complement	2 NO contacts, 1 NC contact
Response time	Opening of inputs (S11/12; S21/22): 15 ms Opening in supply circuit (24 Vac/dc(+)/A1): 50 ms
Contact type	Safety relay, positive-guided
Current Range (min. to max.)	1 mA to 7 A (See Note 1)
Voltage Range (min. to max.)	0,1 to 250 Vac/dc
Switching Capability per ac15 (EN 60947-5-1)	NO contacts: 3 A / 230 V; NC contact: 2 A / 230 V
Typical Electrical Life Expectancy	Power factor = 1 at 230 Vac/dc (See Note 2)
2 A	1 000 000 operations
5 A	220 000 operations
7 A	110 000 operations
Typical Power Factor (cos φ)	Limitation Factor (See Note 3)
0,3	0,45
0,5	0,7
0,7	0,85
1	1
Operating frequency	1200 switching cycles/hour (max.)
Output contact fuse rating	Time delay 6 A (max.)
Mechanical life	Ten million switching operations
General	
Temperature range	-15 °C to +55 °C / 5 °F to 131 °F at 90% humidity (max.)
Sealing	Housing: IP 40 • Terminals: IP 20
Housing material	Thermoplastic
Vibration resistance	Amplitude 0,35 mm; Frequency 10 to 55 Hz
Wire/conductor connection	1 x 2,5 mm ² solid (max.) [14 AWG] or 2 x 1,5 mm ² (max.) [16 AWG] stranded wire with sleeve DIN 46288
Wire/conductor attachment	Removable block terminals with M 3,5 screws; wire contacts are enclosed to prevent electrical shock
Mounting	Quick install rail mounting EN 50022-35, width: 35 mm / 1.38 in
Weight	220 g / 0.49 lb

ORDERING INFORMATION

FF-SRS5925□
 □ = 2 = 24 Vdc (only)

Note 1: Contact damage

To ensure the 1 mA capability during the life-time of the contact, never exceed 300 mA or 60 V.

Note 2: Install arc suppression device across load to avoid module contact arcing and ensure specified relay life expectancy.

Note 3: Total operations = Operations at power factor 1 multiplied by the limitation factor. If the power factor is 0,5 at 230 Vac, 2 A (750 000 operations), the limitation factor is 0,70. 750 000 x 0,70 = 525 000 total operations.

CONTACT LIFE FOR 100% RESISTIVE LOAD (TYPICAL)

(Note 2) Power factor = 1 (cos φ)

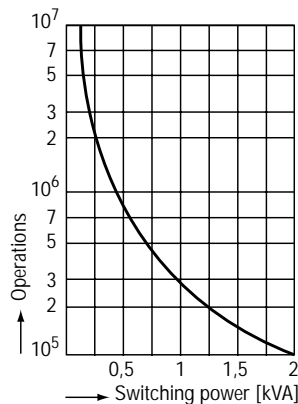

LIMITATION FACTOR FOR INDUCTIVE LOADS

(Note 3) Power factor < 1 (cos φ)

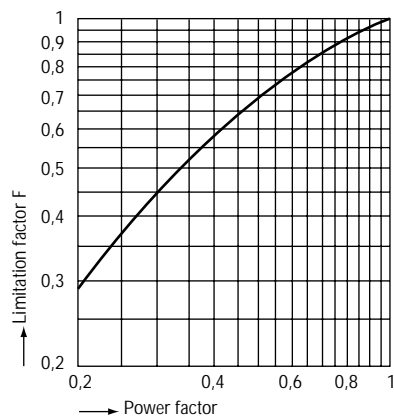

FF-SRS5925

INSTALLATION DIAGRAM

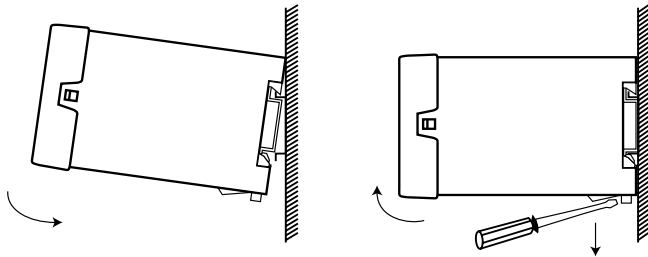

MOUNTING DIMENSIONS

Width: 22,5 mm / 0.89 in; Height: 74 mm / 2.91 in;
Depth: 118 mm / 4.65 in

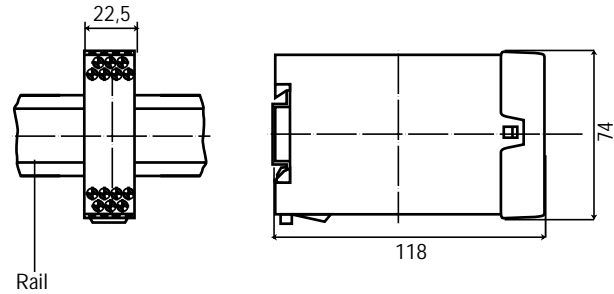

INTERNAL CIRCUITRY

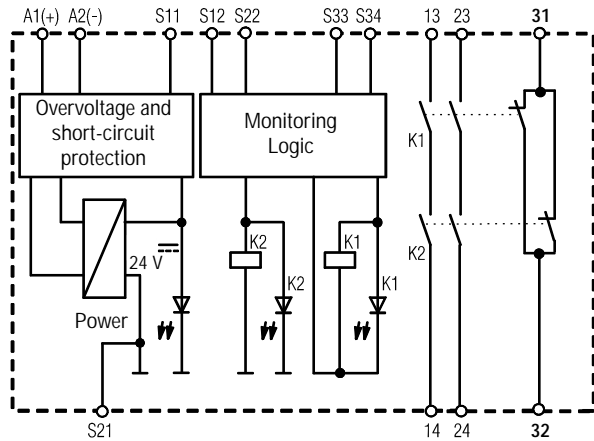

FRONT PANEL

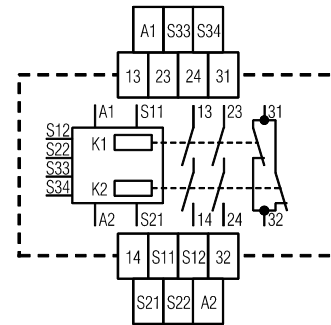

REMOVABLE TERMINAL BLOCKS

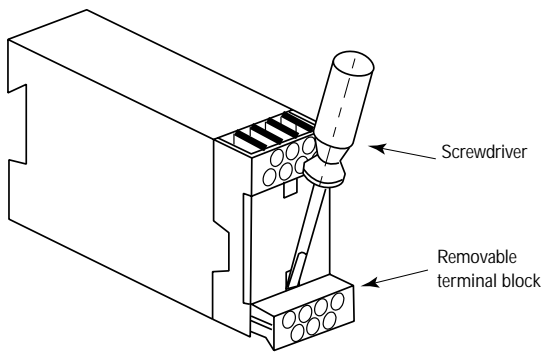

SWITCH SETTINGS (located behind front panel)

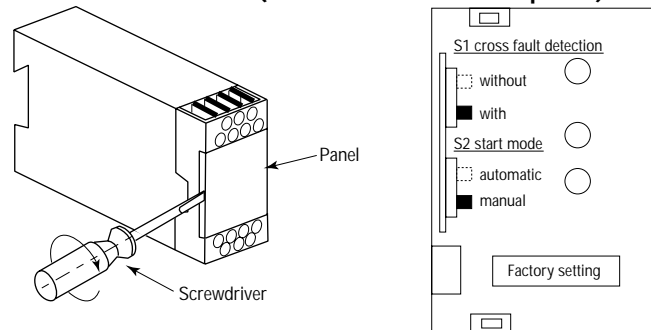

FUNCTIONAL DIAGRAM

Functional description

If the safety device is actuated (emergency stop condition occurs), the internal relays K1 and K2 de-energize, the normally open safety contacts 13/14..23/24 will open immediately and the normally closed safety contact 31/32 will close. This emergency stop condition is relayed via the contacts of the module (and optional external contactors K3/K4) to the machine control circuitry to arrest dangerous motion and/or remove power.

*Line fault Detection on Start push-button

If the start push button is closed before voltage is applied to S12 and S22 the safety contacts of the module cannot close. This additional feature ensures the detection of a line fault via the start push-button or a blocked start push button. In case of a push-button failure the module can not be restarted.

Two switches S1 and S2 are used to select the restart mode and the operating mode for cross fault detection. These switches are located behind the front panel.

Switch S1 is used to select an operating mode for cross fault detection between the two input channels (S11/S12 and S21/S22).

Switch S2 is used to select automatic or manual restart mode. In the automatic restart mode, an additional jumper must be set into the restart loop (S33/S34, see Application Examples).

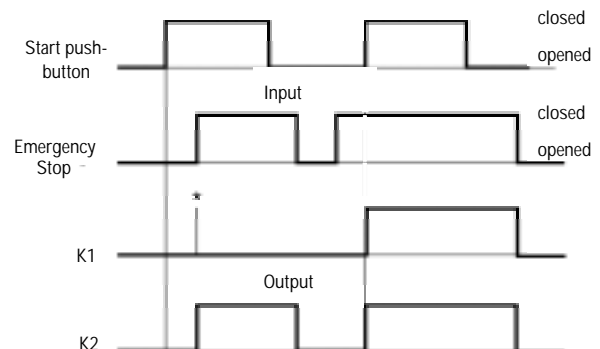

APPLICATION EXAMPLES

Dual-channel emergency stop circuitry (with cross fault monitoring, external contactors)

FF-SRS5925

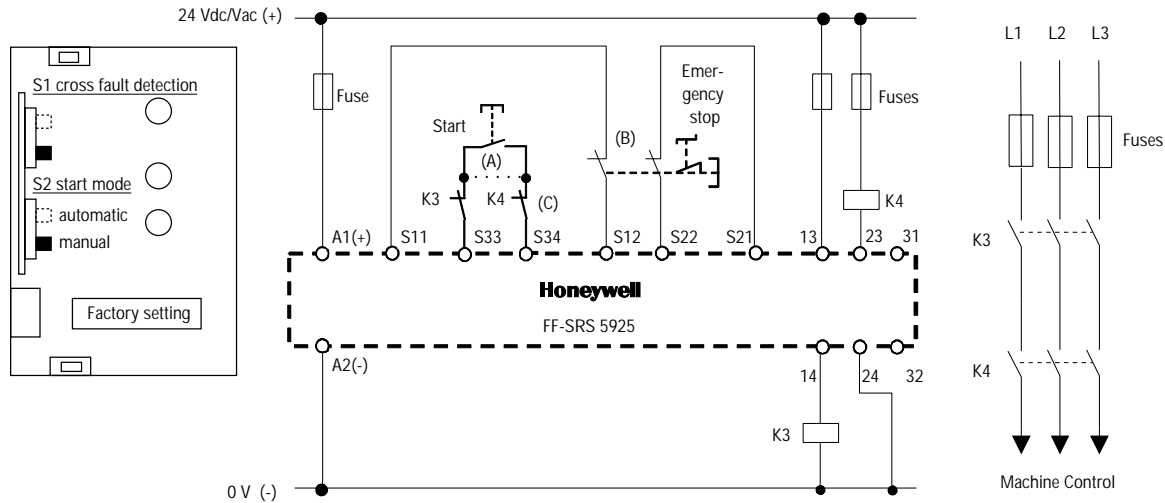

Dual-channel safety door monitoring (with cross fault monitoring, automatic start mode)

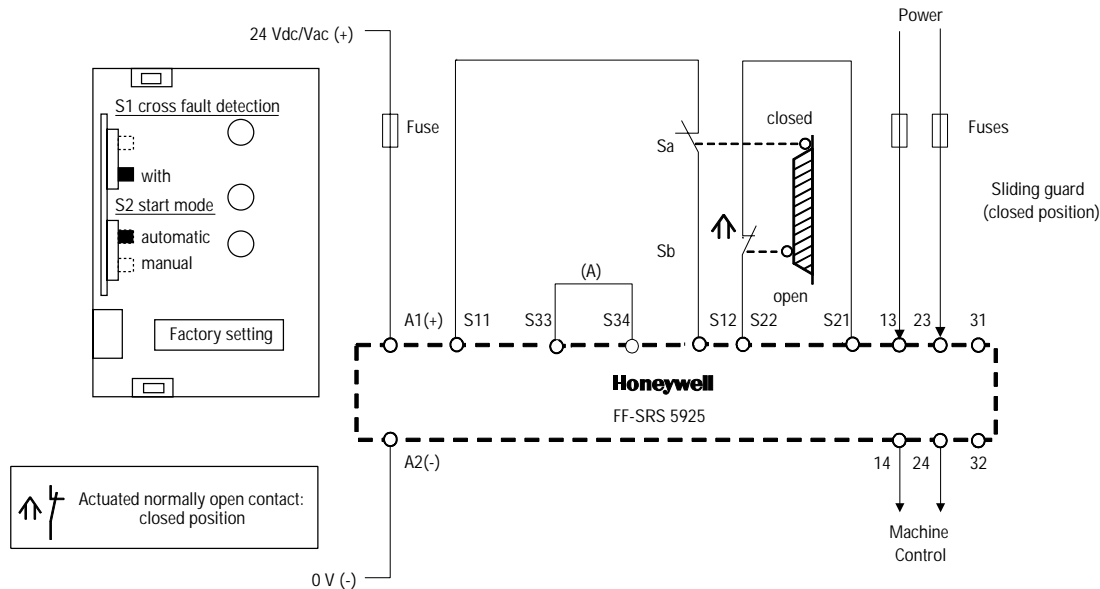

Protective gates are designed to limit or block access to the moving parts of dangerous machinery. These gates can be equipped with locking or interlocking devices, usually safety limit switches or any other safety sensors/switches.

The FF-SRS5925 Emergency Stop module monitors the status of these safety sensor positions. When the protective gate is open, the initiation of dangerous motion is prevented. When the door is closed again, the next machine cycle can start, but only after initiating an external manual restart sequence.

After opening the door, the two external safety switch contacts Sa and Sb will open and the two internal safety relays K1 and K2 will de-energize. The normally open safety outputs 13/14 and 23/24 will open relaying the stop condition to the machine control circuitry. After closing the door, Sa and Sb close and the internal relays K1 and K2 will energize automatically. The two normally open safety contacts will close and an external manual restart sequence may then be initiated (allowing the machine to operate).

Application notes:

Note (A): Start modes:

Manual start mode: Insert start push-button into the start loop S33/S34 and select internal switch to manual start mode

Automatic start mode: Insert jumper into the start loop S33/S34 and select internal switch S2 to automatic start mode

Note (B): Dual channel safety devices:

This may be an emergency stop push-button in series with dual output safety switching devices (OSSD) such as: safety light curtains (FF-SB, FF-LS), single beam (FF-SPS4), modular safety light curtains (FF-SCAN), safety laser scanner (FF-SE), safety mats (FF-SM), dual output safety limit or interlock switches (for example, CLS and GK).

Note (C): External contactors:

With switching currents higher than 7 A, the output contacts should be reinforced by external contactors with positive guided contacts (K3 and K4). The proper operation of the external contactors must be monitored by looping their normally closed contacts in series into the Start loop between S33/S34 (Final Switching Device (FSD) monitoring).