

TMCM-3230 Hardware Manual

Hardware Version V1.30 | Document Revision V1.31 • 2021-SEP-28

The TMCM-3230 is a compact and easy to use 3-axes stepper motor controller and driver unit for embedded applications. It offers CAN bus, UART and USB interfaces for communication and supports stand-alone operation, also. The TMCM-3230 features StealthChop™ for absolute silent motor control, SpreadCycle™ for high speed stepper motor commutation, a fully integrated hardware motion controller with SixPoint™ motion ramps, as well as StallGuard2™ and CoolStep™.

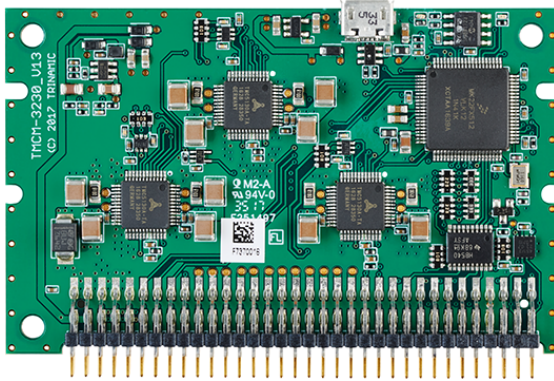

Features

- 3-axes stepper motor controller / driver
- Supply Voltage +12 to +24V DC (9V .. 28.5V max.)
- CAN, UART and USB interfaces
- TMCL or CANopen protocol
- Integrated **SixPoint™** ramp motion controller
- **StealthChop™** silent PWM mode
- **SpreadCycle™** smart mixed decay
- **StallGuard2™** load detection
- **CoolStep™** autom. current scaling

Applications

- Laboratory Automation
- Manufacturing
- Semiconductor Handling
- Robotics
- Factory Automation
- Test & Measurement
- Life Science
- Biotechnology
- Liquid Handling

Simplified Block Diagram

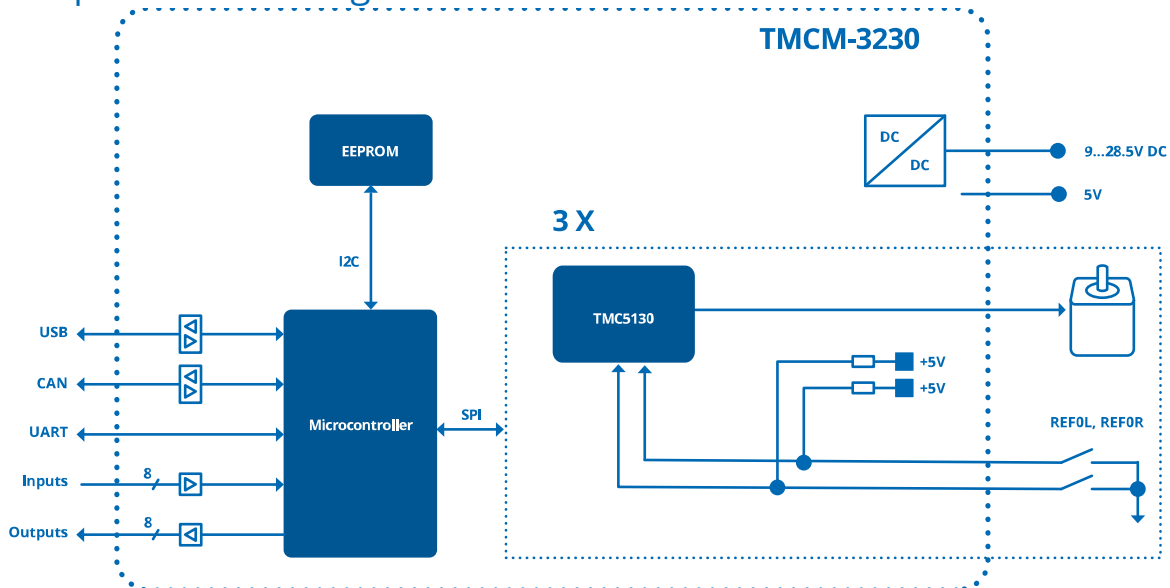

Contents

1	Features	3
1.1	General Features	3
1.2	TRINAMIC's Unique Features	4
1.2.1	stealthChop™	4
1.2.2	spreadCycle™	4
1.2.3	stallGuard2	4
1.2.4	coolStep	5
1.2.5	sixPoint Motion Controller	5
2	Order Codes	7
3	Mechanical and Electrical Interfacing	8
3.1	TMCM-3230 Dimensions	8
4	Connectors and LEDs	9
4.1	Main Connector	9
4.2	USB Connector	10
4.3	CAN Connection	11
4.4	RS232 Connection	12
4.5	RS485 Connection	13
4.6	LEDs	14
5	Motor driver current	15
6	Functional Description	17
7	Migration from TMCM-343 and TMCM-303	18
8	Operational Ratings and Characteristics	20
8.1	Absolute Maximum Ratings	20
8.2	Electrical Characteristics (Ambient Temperature 25° C)	20
8.3	I/O Ratings (Ambient Temperature 25° C)	20
8.4	Other Requirements	21
9	Abbreviations used in this Manual	21
10	Figures Index	22
11	Tables Index	23
12	Supplemental Directives	24
12.1	Producer Information	24
12.2	Copyright	24
12.3	Trademark Designations and Symbols	24
12.4	Target User	24
12.5	Disclaimer: Life Support Systems	24
12.6	Disclaimer: Intended Use	24
12.7	Collateral Documents & Tools	25
13	Revision History	26
13.1	Hardware Revision	26
13.2	Document Revision	26



1 Features

The TMCM-3230 is a compact three axes 2-phase stepper motor controller and driver module. It provides a complete motion control solution at a very small size for embedded applications. The board can be easily plugged into a customized baseboard offering a single 68pin connector.

Host communication is possible via the serial UART interface (e.g. using a standard RS232 or RS485 level shifter) or via CAN (CAN controller is already integrated on board). An additional USB interface (Micro-USB) may be used for firmware updates, download of TMCL programs or setting of parameters - either in system or stand-alone without any further connections.

The TMCM-3230 is supported by the integrated development environment TMCL-IDE v3.0. It supports stand-alone TMCL program execution (on-board EEPROM) and remote controlled operation.

The TMCM-3230 has been designed with compatibility in mind with previous generation TMCM-343/TMCM-303 modules - keeping similar mechanical and electrical characteristics (drop-in replacement for many applications) while offering advanced features.

1.1 General Features

Main Characteristics

- Supply Voltage +12V to +24V DC nom. (9V..28.5V abs. max.)
- 1A RMS phase current (approx. 1.4A peak phase current)
- Up to 256 micro steps per full step
- Permanent onboard parameter storage (EEPROM)
- Advanced SixPoint™ ramp hardware motion controller (for each axis)
- Noiseless StealthChop™ chopper mode for slow to medium velocities
- High performance SpreadCycle™ chopper mode
- High-precision sensorless load measurement with StallGuard2™
- Automatic current scaling algorithm CoolStep™ to save energy and keep your drive cool

I/Os

- 8 general purpose inputs (0..5V) - either analog or digital
- 8 general purpose outputs (+5V level)
- L+R reference switch inputs (for all three axes)
- Shutdown input to power-on/-off drivers
- Alarm output
- Reset input

Communication Interfaces

- Standard CAN Bus Interface for control and configuration
- UART interface supporting e.g. RS232, RS422 or RS485 with external transceiver
- SPI master interface



1.2 TRINAMIC's Unique Features

1.2.1 stealthChop™

stealthChop is an extremely quiet mode of operation for low and medium velocities. It is based on a voltage mode PWM. During standstill and at low velocities, the motor is absolutely noiseless. Thus, stealthChop operated stepper motor applications are very suitable for indoor or home use. The motor operates absolutely free of vibration at low velocities. With stealthChop, the motor current is applied by driving a certain effective voltage into the coil, using a voltage mode PWM. There are no more configurations required except for the regulation of the PWM voltage to yield the motor target current.

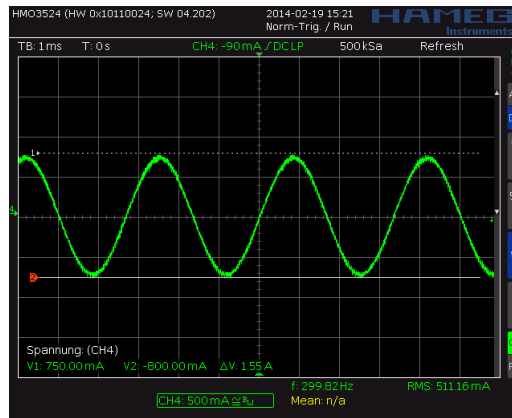

Figure 1: Motor coil sine wave current using stealthChop (measured with current probe)

1.2.2 spreadCycle™

The spreadCycle chopper is a high-precision, hysteresis-based, and simple to use chopper mode, which automatically determines the optimum length for the fast-decay phase. Several parameters are available to optimize the chopper to the application. spreadCycle offers optimal zero crossing performance compared to other current controlled chopper algorithms and thereby allows for highest smoothness. The true target current is powered into the motor coils.

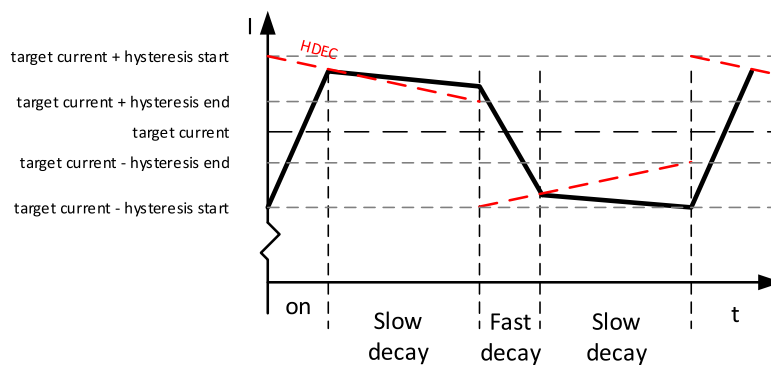

Figure 2: spreadCycle principle

1.2.3 stallGuard2

stallGuard2 is a high-precision sensorless load measurement using the back EMF of the motor coils. It can be used for stall detection as well as other uses at loads below those which stall the motor. The



stallGuard2 measurement value changes linearly over a wide range of load, velocity, and current settings. At maximum motor load, the value reaches zero or is near zero. This is the most energy-efficient point of operation for the motor.

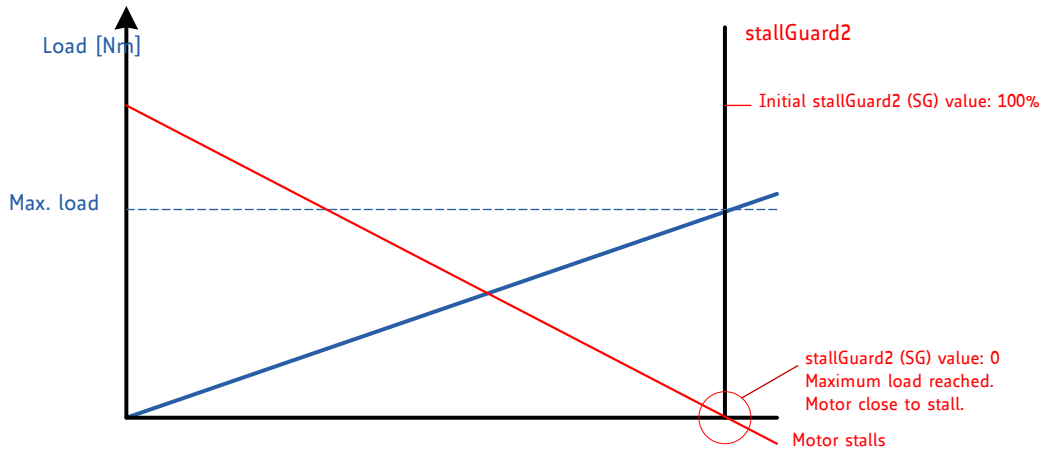

Figure 3: stallGuard2 Load Measurement as a Function of Load

1.2.4 coolStep

coolStep is a load-adaptive automatic current scaling based on the load measurement via stallGuard2. coolStep adapts the required current to the load. Energy consumption can be reduced by as much as 75%. coolStep allows substantial energy savings, especially for motors which see varying loads or operate at a high duty cycle. Because a stepper motor application needs to work with a torque reserve of 30% to 50%, even a constant-load application allows significant energy savings because coolStep automatically enables torque reserve when required. Reducing power consumption keeps the system cooler, increases motor life, and allows for cost reduction.

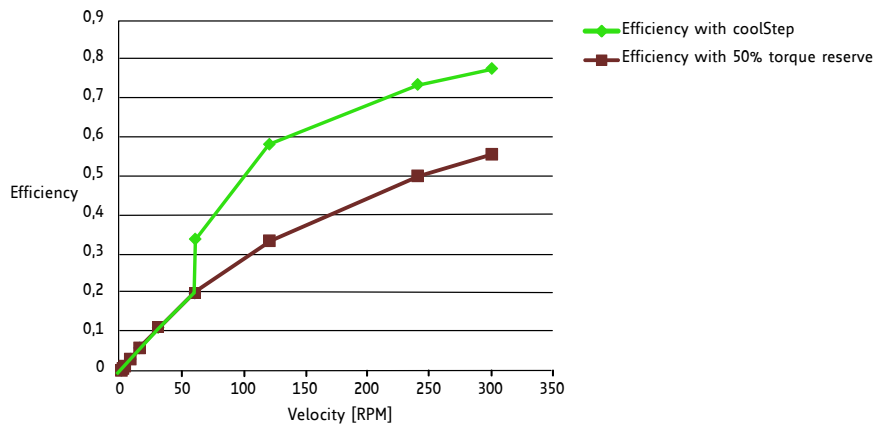

Figure 4: Energy Efficiency Example with coolStep

1.2.5 sixPoint Motion Controller

TRINAMIC's sixPoint motion controller is a new type of ramp generator, which offers faster machine operation compared to the classical linear acceleration ramps. The sixPoint ramp generator allows adapting the



acceleration ramps to the torque curves of a stepper motor and uses two different acceleration settings each for the acceleration phase and for the deceleration phase

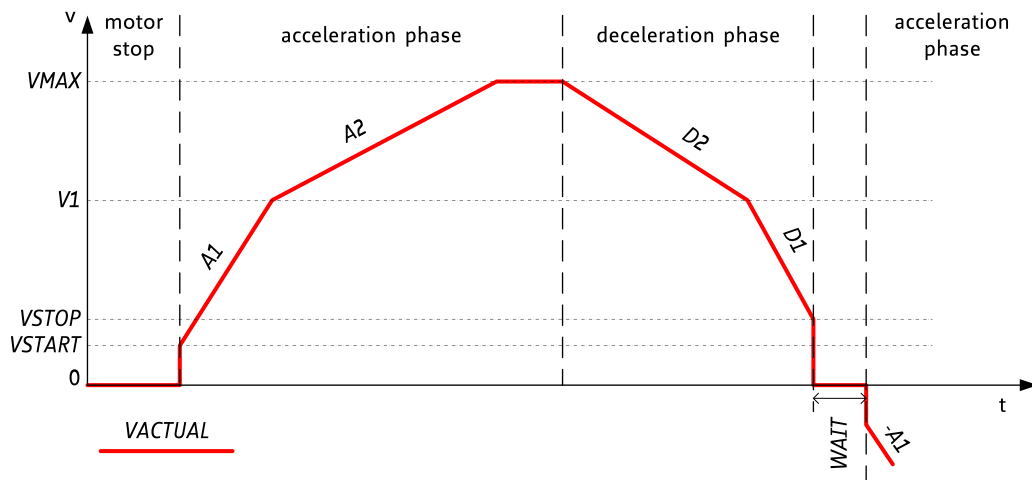

Figure 5: Typical motion profile with TRINAMIC's sixPoint motion controller



2 Order Codes

Order Code	Description	Size (LxWxH)
TMCM-3230-TMCL	3-axes stepper motor controller / driver +24V / 1A RMS TMCL firmware installed	80mm x 50mm x 6mm
TMCM-3230-CANopen	3-axes stepper motor controller / driver +24V / 1A RMS CANopen firmware installed	80mm x 50mm x 6mm

Table 1: Order Codes



3 Mechanical and Electrical Interfacing

3.1 TMCM-3230 Dimensions

The dimensions of the controller/driver unit are approx. 80mm x 50mm. There are three mounting holes for M3 screws and two slots on each side for optional card holders.

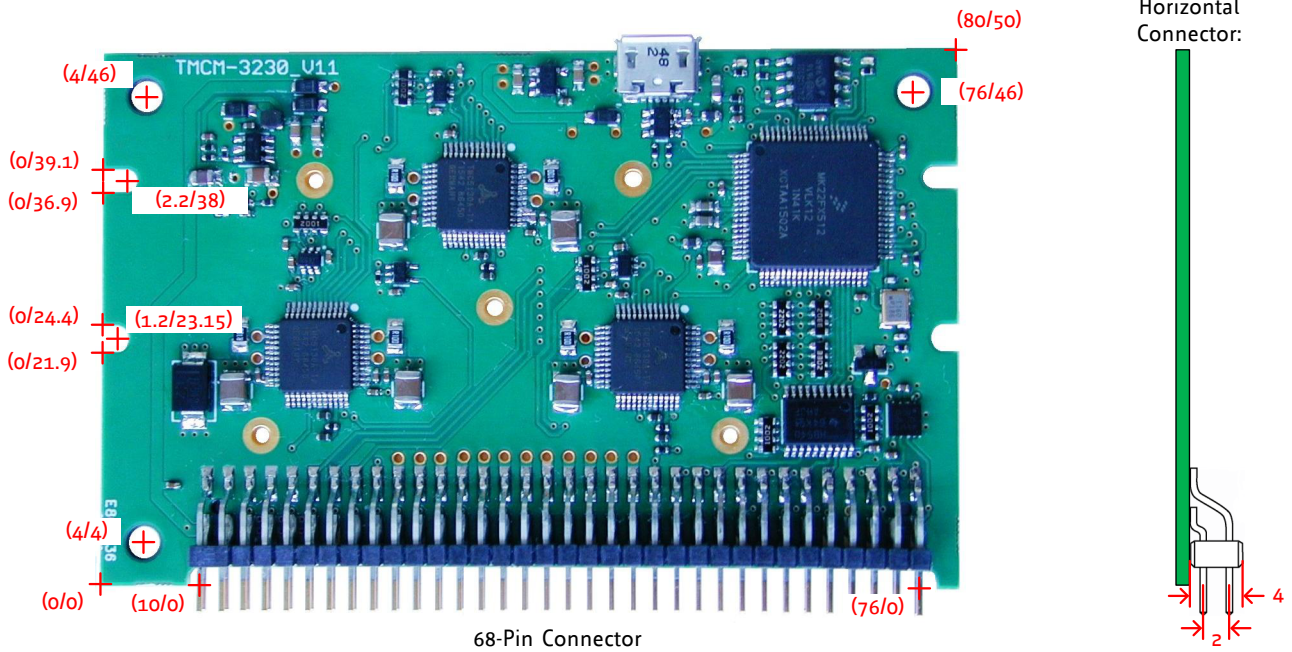

Figure 6: TMCM-3230 mechanical dimensions (all values in mm, (x/y))



4 Connectors and LEDs

4.1 Main Connector

The TMCM-3230 has been designed as plug-in module. It offers one 68pin connector with 2mm pitch for connection of supply (driver and optional +5V digital supply), communication interfaces (CAN, UART - e.g. RS232, RS422 or RS485 with external transceiver), up-to eight digital outputs (0..+5V), up-to eight analog or digital inputs (0..+5V), reference switch inputs for all three axes (may be used as Step/Direction inputs) and motor driver outputs for three axes.

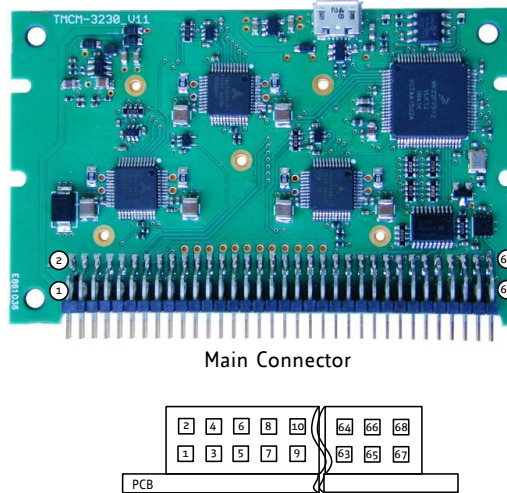

Figure 7: TMCM-3230 main connector

Main Connector Pin Assignment					
Pin	Direction	Description	Pin	Direction	Description
1	In	+5V DC digital supply in (optional)	2	In	GND
3	In	+5V DC digital supply in (optional)	4	In	GND
5	In	+12V..+24V driver supply in	6	In	GND
7	In	+12V..+24V driver supply in	8	In	GND
9	In	+12V..+24V driver supply in	10	In	GND
11	Out	SPI Select 0 (option)	12	Out	SPI Clock (option)
13	-	Reserved	14	In	SPI MISO (option)
15	In	SPI IRQ (option)	16	Out	SPI MOSI (option)
17	In	Reset, active low	18	Out	Alarm
19	In	Motor 0 REFR / DIR	20	Out	Motor 0 A0
21	In	Motor 0 REFL / STEP	22	Out	Motor 0 A1
23	In	Motor 1 REFR / DIR	24	Out	Motor 0 B0
25	In	Motor 1 REFL / STEP	26	Out	Motor 0 B1



Pin	Direction	Description	Pin	Direction	Description
27	In	Motor 2 REFR / DIR	28	Out	Motor 1 A0
29	In	Motor 2 REFL / STEP	30	Out	Motor 1 A1
31	-	Reserved	32	Out	Motor 1 B0
33	-	Reserved	34	Out	Motor 1 B1
35	-	Reserved	36	Out	Motor 2 A0
37	-	Reserved	38	Out	Motor 2 A1
39	-	Reserved	40	Out	Motor 2 B0
41	-	Reserved	42	Out	Motor 2 B1
43	-	Reserved	44	In	Shutdown (2k2 pull-up to +5V)
45	In	General purpose input 0	46	Out	General purpose output 0
47	In	General purpose input 1	48	Out	General purpose output 1
49	In	General purpose input 2	50	Out	General purpose output 2
51	In	General purpose input 3	52	Out	General purpose output 3
53	In	General purpose input 4	54	Out	General purpose output 4
55	In	General purpose input 5	56	Out	General purpose output 5
57	In	General purpose input 6	58	Out	General purpose output 6
59	In	General purpose input 7	60	Out	General purpose output 7
61	In	GND	62	In	GND
63	-	Reserved	64	Out	RS485 Direction
65	In and Out	CAN-	66	In	UART_RxD
67	In and Out	CAN+	68	Out	UART_TxD

Table 2: Main Connector Pin Assignment

NOTICE

Do not plug-in or remove TMCM-3230 during operation! Voltage spikes and / or partly connected supply pins might lead to permanent damage of the module.

4.2 USB Connector

The TMCM-3230 offers one Micro-USB connector. This connector is located at the upper end of the plug-in module. It has been integrated for quick and easy parameter setting and firmware updates of the module - either in-system or even while the main connector is un-plugged. The USB device interface (Full-speed) supports USB bus powered operation. During this mode the processor and the on-board non-volatile memory (EEPROM) are powered and firmware updates, download of TMCL programs and parameter setting is possible without any further connection - apart from USB. In addition, UART communication, the SPI interface, all general purpose inputs and outputs, Alarm output, the CAN interface and the dedicated Reset input are operational while motor driver outputs and motor controller / driver related REF / Step / Dir inputs are not operational.

In self powered mode when the TMCM-3230 is plugged into its mainboard and power via the 68pin connector is applied communication via USB is possible, also. In this configuration USB might be used as an



alternative to the other serial interfaces. Please note that the module might draw current via the USB connection in this mode, also.

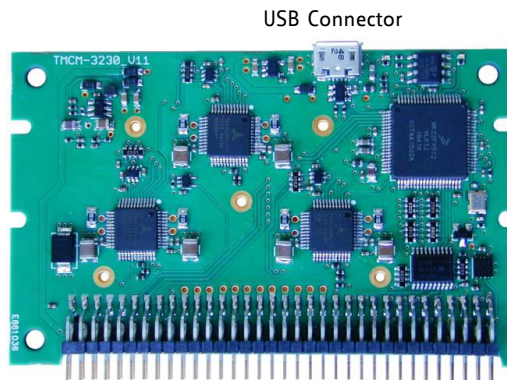

Figure 8: TMCM-3230 USB Connector

4.3 CAN Connection

For remote control and communication with a host system the TMCM-3230 provides a CAN bus interface with on-board CAN transceiver.

Main Connector Pin Assignment		
Pin	Direction	Description
65	In and Out	CAN-, CAN bus connection, inverting
67	In and Out	CAN+, CAN bus connection, non-inverting

Table 3: Main Connector CAN connection

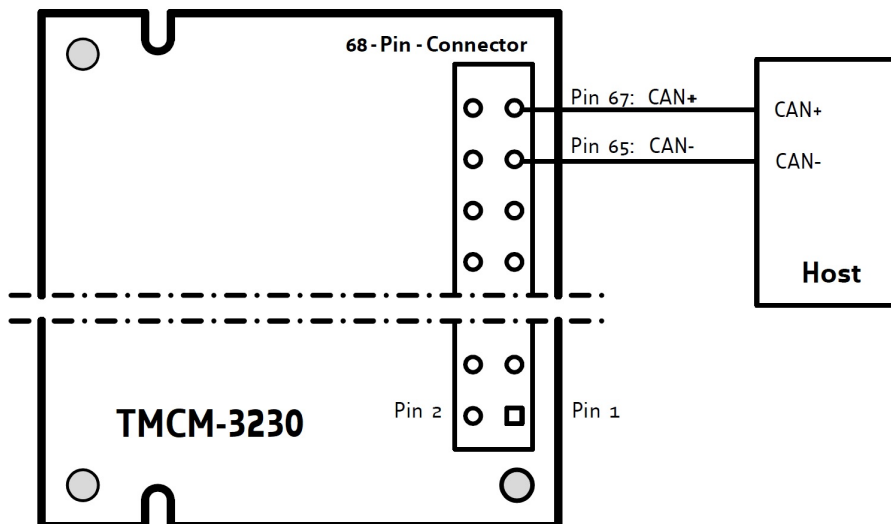

Figure 9: TMCM-3230 Connecting CAN



For proper operation the following items should be taken into account when setting up a CAN network:

Bus Structure The network topology should follow a bus structure as closely as possible. That is, the connection between each node and the bus itself should be as short as possible. Basically, it should be short compared to the length of the bus.

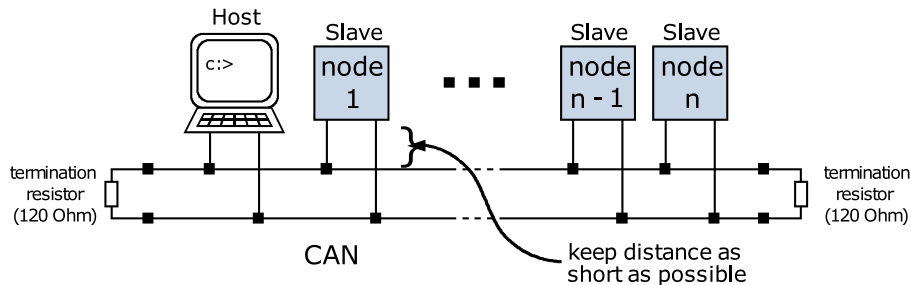

Figure 10: CAN Bus Structure

Bus Termination Especially for longer busses and/or multiple nodes connected to the bus and/or high communication speeds, the bus should be properly terminated at both ends. The TMCM-3230 does not integrate any termination resistor. Therefore, 120 Ohm termination resistors at both ends of the bus have to be added externally.

Number of Nodes The bus transceiver used on the TMCM-3230 (TJA1051) supports at least 100 nodes under optimum conditions. Practically achievable number of nodes per CAN bus highly depend on bus length (longer bus = less nodes) and communication speed (higher speed = less nodes).

4.4 RS232 Connection

For remote control and communication with a host system the TMCM-3230 provides a UART interface (+3V3 serial data output and +5V tolerant serial data input).

Main Connector Pin Assignment		
Pin	Direction	Description
66	In	UART_RxD, recieve data in (+5V tolerant)
68	Out	UART_TxD, transmit data out (+3V3 level)
2,4,6,8,10,61,62	GND	connect to GND

Table 4: Main Connector UART connection



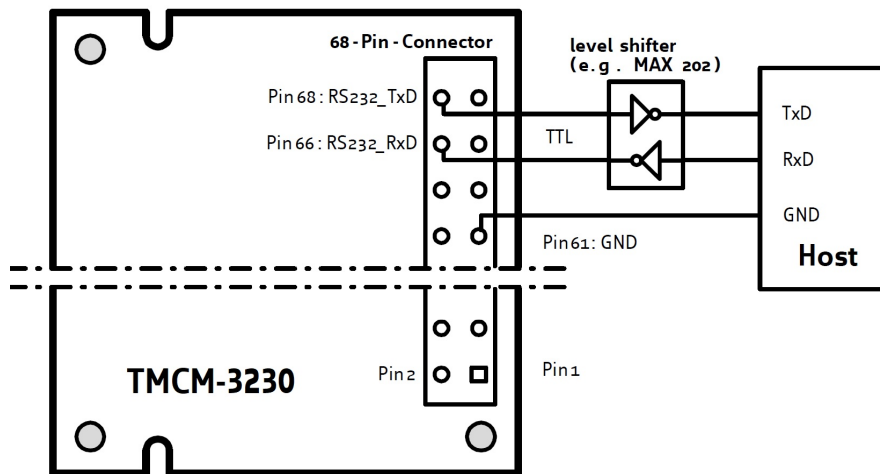

Figure 11: TMCM-3230 Connecting RS232

4.5 RS485 Connection

For remote control and communication with a host system the TMCM-3230 provides a UART interface (+3V3 serial data output and +5V tolerant serial data input).

Main Connector Pin Assignment		
Pin	Direction	Description
64	Out	RS485 Direction, Driver / receiver enable for RS485 transceiver (+3V3 level) 0: receiver enable 1: driver enable
66	In	UART_RxD, receive data in (+5V tolerant)
68	Out	UART_TxD, transmit data out (+3V3 level)
2,4,6,8,10,61,62	GND	connect to GND

Table 5: Main Connector UART connection



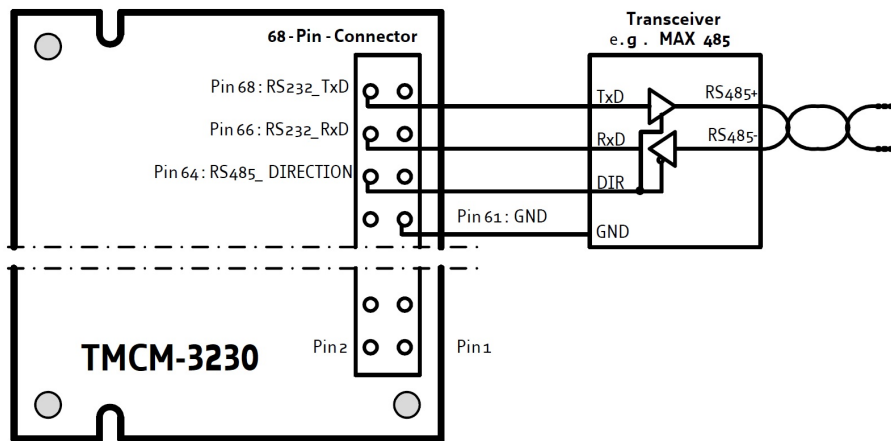

Figure 12: TMCM-3230 Connecting RS485

4.6 LEDs

The TMCM-3230 offers two LEDs: one green and one red LED. Both LEDs are connected to the processor. Function of the LEDs depends on the firmware version / type of firmware (e.g. TMCL / CANopen). See figure 13 for the LED location.

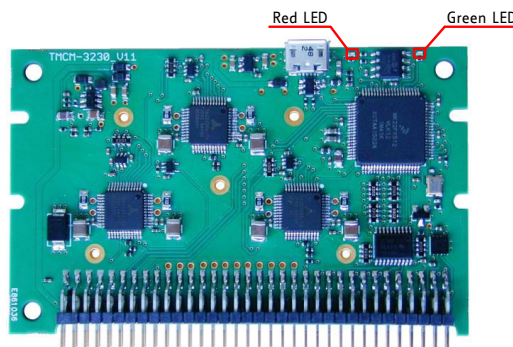

Figure 13: TMCM-3230 Location of LEDs

Status LEDs with TMCL Firmware		
Green LED	Red LED	TMCL Firmware
Blinking	Off	Operational, firmware is running.
On	On	Bootloader / firmware update mode.
Off	Off	Power Off

Table 6: Status LEDs with TMCL Firmware



5 Motor driver current

The on-board stepper motor driver operates current controlled. The driver current may be programmed in software with 32 effective current scaling steps (CS) in hardware.

Explanation of different columns in table below:

- Motor current setting in software (TMCL)** These are the values for TMCL axis parameter 6 (motor run current) and 7 (motor standby current). They are used to set the run / standby current using the following TMCL commands:

SAP 6, 0, <value> // set run current

SAP 7, 0, <value> // set standby current

(read-out value with GAP instead of SAP. Please see separate TMCM-3230 firmware manual for further information)
- Current scaling** This is the effective current scaling in hardware. 32 different scaling steps are available in hardware.
- Motor current** Resulting motor current based on motor current setting. Motor current is listed as peak (sine peak) value (I_{PEAK}) and RMS-value (I_{RMS}). For stepper motors rated current is usually listed as I_{RMS} value.

Motor current setting in software (TMCL)	Current scaling step in hardware (CS)	Motor current $I_{PEAK}[A]$	Motor current $I_{RMS}[A]$
0..7	0	0.047	0.033
8..15	1	0.094	0,066
16..23	2	0.141	0.099
24..31	3	0.188	0.133
32..39	4	0.234	0.166
40..47	5	0.281	0.199
48..55	6	0.328	0.232
56..63	7	0.375	0.265
64..71	8	0.422	0.298
72..79	9	0.469	0.331
80..87	10	0.516	0.365
88..95	11	0.563	0.398
96..103	12	0.609	0.431
104..111	13	0.656	0.464
112..119	14	0.703	0.497
120..127	15	0.750	0.530
128..135	16	0.797	0.563
136..143	17	0.844	0.597



Motor current setting in software (TMCL)	Current scaling step in hardware (CS)	Motor current $I_{PEAK}[A]$	Motor current $I_{RMS}[A]$
144..151	18	0.891	0.630
152..159	19	0.938	0.663
160..167	20	0.984	0.696
168..175	21	1.031	0.729
176..183	22	1.078	0.762
184..191	23	1.125	0.795
192..199	24	1.172	0.829
200..207	25	1.219	0.862
208..215	26	1.266	0.895
216..223	27	1.313	0.928
224..231	28	1.359	0.961
232..239	29	1.406	0.994
240..247	30	1.453	1.028
248..255	31	1.500	1.061

In addition to the settings in the table the motor current may be switched off completely (free-wheeling) using axis parameter 204 (see TMC3230 firmware manual).



6 Functional Description

The TMCM-3230 contains the following main parts:

- 3x TMC5130 combined stepper motor controller and driver
- processor running the TMCL interpreter or the CANopen stack (depending on firmware version)
- non-volatile memory for parameter and TMCL program storage (EEPROM)
- Input and output level shifter / buffer
- USB interface (with micro-USB connector), CAN interface with on-board transceiver and UART interface supporting external RS232, RS422 or RS485 connections
- SPI master interface

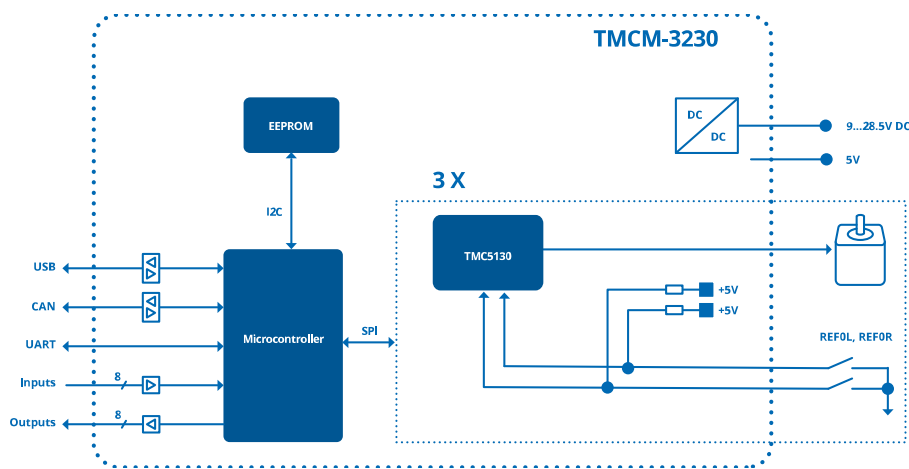

Figure 14: Typical application scenario



7 Migration from TMCM-343 and TMCM-303

The TMCM-3230 has been designed as an upgrade for the older TMCM-343 and TMCM-303 modules. It offers the same basic pcb dimensions and shape and the same main connector with the same pin assignment for all major pins. The TMCM-3230 supports three stepper motor axes as its predecessor with similar motor current and supply voltage range and functionality. Nevertheless, as this unit is based on our latest generation of stepper motor drivers with integrated motion controller and a more powerful main processor there are several enhancements included:

- driver with 256 microsteps: the higher microstep resolution leads to different settings for velocity and position. Please refer to the firmware manual for additional information
- integrated motion controller offering linear and 6-point ramps: In contrast to the TMCM-303 and TMCM-343 no pre-scaler for velocity and acceleration are required. Also, there are a number of additional configuration options for the advanced motion controller available. Please refer to firmware manual for more information.
- Speed of TMCL program execution: TMCL program execution is several times faster than on the original TMCM-303.
- CAN: the default CAN bit rate for the TMCM-3230 is 1Mbit/s. This is the same as for the TMCM-343 but, different from the 250kbit/s which has been default for the original TMCM-303. Please refer to the TMCM-3230 firmware manual for more details.
- Integrated USB: USB interface has been added in order to simplify firmware updates and parameter settings / read-out without any further connection or even when installed in the machine. This interface has been missing on the older versions.
- Integrated +5V switching regulator: the TMCM-3230 offers an integrated +5V switching regulator. While the separate +5V supply is still available on the main pin header the on-board digital logic is supplied / powered as soon as the main / driver supply is applied to the module. This ensures the digital logic will be working regardless of the +5V supply input and possible power-up delays etc. which sometimes proved to be difficult with previous designs.
- operating voltage range: the power supply voltage range has been adapted with respect to the driver stage and the integrated switching regulator. The typical supply voltage range remains the same as with the older board designs.
- Integrated pull-down on general purpose inputs (55k): the TMCM-3230 and its direct predecessor - the TMCM-343 - uses +3V3 I/O supply for its on-board digital logic. In order to remain compatible with the TMCM-303 with +5V general purpose input voltage levels a resistor voltage divider for the inputs has been integrated (same as for the TMCM-343).
- RS232_TTL / UART interface: In contrast to the CAN interface the TMCM-3230 misses a transceiver for RS232, RS422 or RS485 interface on-board. Nevertheless, it offers the necessary signals (UART_RXD, UART_TXD and RS485 Direction) in order to control an external transceiver of choice. This is the same design as for the previous TMCM-303 and TMCM-343. Nevertheless, please note: the signal levels for the UART_TXD and RS485 Direction output signals are +3V3 (same as for the TMCM-343) and not +5V as for the TMCM-303. The input signals UART_RXD remains +5V tolerant. This way it usually should be possible to connect standard transceiver ICs without any compatibility issues.
- integrated ADC resolution: the analog-to-digital converter integrated into the on-board processor offers up-to 16bit resolution. This is different from the TMCM-343 and TMCM-303 (10bit resolution) and results in different range of values.
- SPI interface: all SPI related output signals are +3V3 logic signals. All SPI related input signals are +5V tolerant. Support for external SPI devices depends on firmware version. Please refer to firmware manual for more information on standard firmware support.



While most parameters and commands for the TMCL version are similar to previous versions, parameter ranges have been adjusted in order to support the enhanced features (e.g. up-to 256 microsteps, ramp generator with linear and 6-point ramp etc.). Please refer to firmware manual for more details.



8 Operational Ratings and Characteristics

8.1 Absolute Maximum Ratings

Parameter	Min	Max	Unit
DC Power supply voltage for operation	9	28.5	V
+5V DC input (optional)	4.8	5.2	V
Motor coil current / sine wave peak		1.4	A
Continuous motor current (RMS)		1	A
Working / environmental temperature	-30 ^{*)}	+40 ^{**)}	° C

Table 8: Absolute Maximum Ratings

^{*)} limited by test equipment. Operation down to -40° C can be expected. Test included cold start at this temperature.

^{**)} constant air flow or heat sink (e.g. mounted to the backside of the pcb (Attention: please make sure to isolate heatsink from pcb)) may be required. All components are specified for operation up-to at least +85° C

NOTICE

Stresses above those listed under "Absolute Maximum Ratings" may cause permanent damage to the device. This is a stress rating only and functional operation of the device at those or any other conditions above those indicated in the operation listings of this specification is not implied. Exposure to maximum rating conditions for extended periods may affect device reliability.

8.2 Electrical Characteristics (Ambient Temperature 25° C)

Parameter	Symbol	Min	Typ	Max	Unit
DC Power supply voltage for operation	VDD	9	12..24	28	V
Motor coil current / sine wave peak (chopper regulated, adjustable in software)	I _{COIL peak}	0		1.4	A
Continuous motor current (RMS)	I _{COIL RMS}	0		1.0	A
Power supply current	I _{DD}		≪ I _{COIL}	1.4 * I _{COIL}	A

Table 9: Electrical Characteristics

8.3 I/O Ratings (Ambient Temperature 25° C)

Parameter	Symbol	Min	Typ	Max	Unit
Input voltage for general purpose inputs	V _{IN}	0	0..5	5.5	V
Output voltage for general purpose outputs	V _{OUT}	0	0..5	5.5	V



Parameter	Symbol	Min	Typ	Max	Unit
-----------	--------	-----	-----	-----	------

Table 10: I/O Ratings

8.4 Other Requirements

Specifications	Description or Value
Cooling	Free air
Working environment	Avoid dust, water, oil mist and corrosive gases, no condensation, no frosting
Working temperature	tbd

Table 11: Other Requirements and Characteristics

9 Abbreviations used in this Manual

Abbreviation	Description
CAN	Controller Area Network
COMM	Common Anode or common cathode
IDE	Integrated Development Environment
LED	Light Emmitting Diode
RMS	Root Mean Square value
TMCL	TRINAMIC Motion Control Language
TTL	Transistor Transistor Logic
UART	Universal Asynchronous Receiver Transmitter
USB	Universal Serial Bus

Table 12: Abbreviations used in this Manual



10 Figures Index

1	Motor coil sine wave current using stealthChop (measured with current probe)	4	6	TMCM-3230 mechanical dimensions (all values in mm, (x/y))	8
2	spreadCycle principle	4	7	TMCM-3230 main connector	9
3	stallGuard2 Load Measurement as a Function of Load	5	8	TMCM-3230 USB Connector	11
4	Energy Efficiency Example with coolStep	5	9	TMCM-3230 Connecting CAN	11
5	Typical motion profile with TRI-NAMIC's sixPoint motion controller	6	10	CAN Bus Structure	12
			11	TMCM-3230 Connecting RS232	13
			12	TMCM-3230 Connecting RS485	14
			13	TMCM-3230 Location of LEDs	14
			14	Typical application scenario	17



11 Tables Index

1	Order Codes	7	9	Electrical Characteristics	20
2	Main Connector Pin Assignment	10	10	I/O Ratings	21
3	Main Connector CAN connection	11	11	Other Requirements and Characteristics	21
4	Main Connector UART connection	12	12	Abbreviations used in this Manual	21
5	Main Connector UART connection	13	13	Hardware Revision	26
6	Status LEDs with TMCL Firmware	14	14	Document Revision	26
8	Absolute Maximum Ratings	20			



12 Supplemental Directives

12.1 Producer Information

12.2 Copyright

TRINAMIC owns the content of this user manual in its entirety, including but not limited to pictures, logos, trademarks, and resources. © Copyright 2021 TRINAMIC. All rights reserved. Electronically published by TRINAMIC, Germany.

Redistribution of sources or derived formats (for example, Portable Document Format or Hypertext Markup Language) must retain the above copyright notice, and the complete data sheet, user manual, and documentation of this product including associated application notes; and a reference to other available product-related documentation.

12.3 Trademark Designations and Symbols

Trademark designations and symbols used in this documentation indicate that a product or feature is owned and registered as trademark and/or patent either by TRINAMIC or by other manufacturers, whose products are used or referred to in combination with TRINAMIC's products and TRINAMIC's product documentation.

This Hardware Manual is a non-commercial publication that seeks to provide concise scientific and technical user information to the target user. Thus, trademark designations and symbols are only entered in the Short Spec of this document that introduces the product at a quick glance. The trademark designation /symbol is also entered when the product or feature name occurs for the first time in the document. All trademarks and brand names used are property of their respective owners.

12.4 Target User

The documentation provided here, is for programmers and engineers only, who are equipped with the necessary skills and have been trained to work with this type of product.

The Target User knows how to responsibly make use of this product without causing harm to himself or others, and without causing damage to systems or devices, in which the user incorporates the product.

12.5 Disclaimer: Life Support Systems

TRINAMIC Motion Control GmbH & Co. KG does not authorize or warrant any of its products for use in life support systems, without the specific written consent of TRINAMIC Motion Control GmbH & Co. KG.

Life support systems are equipment intended to support or sustain life, and whose failure to perform, when properly used in accordance with instructions provided, can be reasonably expected to result in personal injury or death.

Information given in this document is believed to be accurate and reliable. However, no responsibility is assumed for the consequences of its use nor for any infringement of patents or other rights of third parties which may result from its use. Specifications are subject to change without notice.

12.6 Disclaimer: Intended Use

The data specified in this user manual is intended solely for the purpose of product description. No representations or warranties, either express or implied, of merchantability, fitness for a particular purpose



or of any other nature are made hereunder with respect to information/specification or the products to which information refers and no guarantee with respect to compliance to the intended use is given.

In particular, this also applies to the stated possible applications or areas of applications of the product. TRINAMIC products are not designed for and must not be used in connection with any applications where the failure of such products would reasonably be expected to result in significant personal injury or death (safety-Critical Applications) without TRINAMIC's specific written consent.

TRINAMIC products are not designed nor intended for use in military or aerospace applications or environments or in automotive applications unless specifically designated for such use by TRINAMIC. TRINAMIC conveys no patent, copyright, mask work right or other trade mark right to this product. TRINAMIC assumes no liability for any patent and/or other trade mark rights of a third party resulting from processing or handling of the product and/or any other use of the product.

12.7 Collateral Documents & Tools

This product documentation is related and/or associated with additional tool kits, firmware and other items, as provided on the product page at: www.trinamic.com.



13 Revision History

13.1 Hardware Revision

Version	Date	Author	Description
1.00	2016-JUN-30	GE	Initial prototpyes.
1.10	2016-NOV-11	GE	Major redesign.
1.20	2107-FEB-28	GE	Minor corrections in order to improve compatibility with previous generation TMCM-343 / TMCM-303
1.30	2017-APR-12	GE	Power supply buffer capacitors added and mounting holes for heatsink removed. First series version.

Table 13: Hardware Revision

13.2 Document Revision

Version	Date	Author	Description
0.90	2016-DEC-12	GE	Initial release.
0.91	2017-JUL-12	GE	New hardware version added. Infos for series version added.
0.92	2017-SEP-05	GE	Minimum driver supply voltage adapted to series version.
1.00	2017-OCT-10	OK	Product picture on first page changed.
1.10	2017-NOV-02	GE	Size of module in order codes corrected.
1.20	2019-MAR-01	GE	USB powered mode description corrected.
1.30	2020-MAR-04	GE	CAN, RS232 and RS485 connection added. Board migration (TMCM-303, TMCM-343) information added.
1.31	2021-SEP-28	OK	New block diagram.

Table 14: Document Revision

