

General Description

The Himalaya series of voltage regulator ICs and power modules enable cooler, smaller, and simpler power supply solutions. The MAXM17502 is a high-voltage, step-down power module in a family of pin-to-pin compatible modules with built-in thermally efficient system-in-packages (SiPs). The device includes a switch mode power supply controller, MOSFETs, an inductor, as well as the compensation components. The device operates from a 4.5V to 60V input supply voltage and supports adjustable output voltage from 0.9V to 5.0V with an output current of 1A. The high level of integration significantly reduces design complexity, manufacturing risks, and offers a true plug-and-play power supply solution to reduce time to market.

The pin-to-pin compatibility within this family of modules allows design flexibility as the design requirements change. For sequencing purpose, the device features adjustable soft-start time, programmable EN/UVLO threshold, and a power-good indicator ($\overline{\text{RESET}}$ pin).

The MAXM17502 is available in a thermally enhanced, compact, 28-pin, 6.5mm x 10mm x 2.8mm SiP package. It operates over the -40°C to +125°C industrial temperature range.

Applications

- Industrial Sensors and Process Control
- High-Voltage LDO Replacement
- Battery-Powered Equipment
- HVAC and Building Control
- General-Purpose Point-of-Load

Benefits and Features

- Reduces Design Complexity, Manufacturing Risks, and Time to Market
 - Integrated Switching Power Supply Controller and Dual-MOSFET Power Switches
 - Integrated Inductor
 - Integrated Compensation Components
 - Integrated Thermal-Fault Protection
 - Integrated Peak Current Limit
- Saves Board Space in Space-Constrained Applications
 - Complete Integrated Step-Down Power Supply in a Single Package
 - Small Profile 6.5mm x 10mm x 2.8mm SiP Package
 - Simplified PCB Design with Minimal External BOM Components
- Offers Flexibility for Power-Design Optimization
 - Wide Input Voltage Range from 4.5V to 60V
 - Output Voltage Adjustable Range from 0.9V to 5.0V
 - Delivers up to 1A Current
 - Shutdown Current as Low as 0.9 μ A (typ)
 - $\pm 1.8\%$ System Accuracy
 - Fixed-Frequency PWM
 - Programmable Soft-Start and Prebias Startup
 - Optional Programmable EN/UVLO
 - Robust Operation
 - Open-Drain Power Good Output ($\overline{\text{RESET}}$ pin)
 - -40°C to +125°C Industrial/Automotive Temperature Range

Ordering Information appears at end of data sheet.

Absolute Maximum Ratings

V_{IN} to PGND	-0.3V to +70V	GND to PGND	-0.3V to +0.3V
EN to GND	-0.3V to ($V_{IN} + 0.3V$)	Operating Temperature Range	-40°C to +125°C
FB, $\overline{\text{RESET}}$, COMP, SS to GND	-0.3V to +6V	Junction Temperature	+125°C
V_{CC} to GND	-0.3V to 6V	Storage Temperature Range	-65°C to +125°C
OUT to PGND ($V_{IN} < 10V$)	-0.3V to ($V_{IN} + 0.3V$)	Lead Temperature (soldering, 10s)	+245°C
OUT to PGND ($V_{IN} > 10V$)	-0.3V to +10V		
LX to PGND	-0.3V to ($V_{IN} + 0.3V$)		

Stresses beyond those listed under "Absolute Maximum Ratings" may cause permanent damage to the device. These are stress ratings only; functional operation of the device at these or any other conditions beyond those indicated in the operational sections of the specifications is not implied. Exposure to absolute maximum rating conditions for extended periods may affect device reliability.

Package Information

PACKAGE TYPE: 28 SiP	
Package Code	L286510+2
Outline Number	21-1073
Land Pattern Number	90-100009
THERMAL RESISTANCE (Note 1)	
Junction to Ambient (θ_{JA})	30°C/W

Note 1: Package Thermal Resistance data taken using MAXM17502EVKIT# evaluation kit.

For the latest package outline information and land patterns (footprints), go to www.maximintegrated.com/packages. Note that a "+", "#", or "-" in the package code indicates RoHS status only. Package drawings may show a different suffix character, but the drawing pertains to the package regardless of RoHS status.

Electrical Characteristics

($V_{IN} = +24V$, $V_{GND} = V_{PGND} = 0V$, $C_{IN} = 2.2\mu F$, $V_{EN} = 1.5V$, $C_{OUT} = 22\mu F$, $V_{FB} = V_{OUT}$, $SS = COMP = \overline{RESET} = \text{unconnected}$. $T_A = T_J = -40^\circ C$ to $+125^\circ C$, unless otherwise noted. Typical values are at $T_A = +25^\circ C$. All voltages are referenced to GND, unless otherwise noted.) (Note 2)

PARAMETER	SYMBOL	CONDITIONS	MIN	TYP	MAX	UNITS
INPUT SUPPLY (V_{IN})						
IN Voltage Range	V_{IN}		4.5		60	V
IN Supply Current	I_{IN-SH}	$V_{EN} = 0V$, shutdown mode		0.9	3.5	μA
	I_{IN-SW}	Normal switching mode, no load, $V_{FB} = 0V$		5		mA
ENABLE (EN)						
EN Threshold	V_{ENR}	V_{EN} rising	1.18	1.218	1.25	V
	V_{ENF}	V_{EN} falling	1.105	1.135	1.165	
	$V_{EN-TRUESD}$	V_{EN} falling, true shutdown		0.7		
EN Input Leakage Current	I_{EN}	$V_{EN} = V_{IN} = 60V$; $T_A = +25^\circ C$		8	200	nA
INTERNAL LDO (V_{CC})						
V_{CC} Output Voltage Range	V_{CC}	$6V < V_{IN} < 12V$, $0mA < I_{VCC} < 10mA$	4.65	5	5.35	V
		$12V < V_{IN} < 60V$, $0mA < I_{VCC} < 2mA$				
V_{CC} Current Limit	$I_{VCC-MAX}$	$V_{CC} = 4.3V$, $V_{IN} = 12V$	15	40	80	mA
V_{CC} Dropout	V_{CC-DO}	$V_{IN} = 4.5V$, $I_{VCC} = 5mA$	4.1			V
V_{CC} UVLO	V_{CC-UVR}	V_{CC} rising	3.85	4	4.15	V
	V_{CC-UVF}	V_{CC} falling	3.55	3.7	3.85	
SOFT-START (SS)						
Charging Current	I_{SS}	$V_{SS} = 0.5V$	4.7	5	5.3	μA
Soft-Start Time	t_{SS}			1.8		ms
FEEDBACK (FB)						
FB Regulation Voltage	V_{FB_REG}		0.884	0.9	0.916	V
FB Input Bias Current	I_{FB}	$T_A = +25^\circ C$			100	nA
OUTPUT VOLTAGE (V_{OUT})						
Line Regulation Accuracy		$V_{IN} = 4.5V$ to $60V$, no load and PWM operation		0.2		mV/V
Load Regulation Accuracy		$0 < I_{OUT} < 1A$; $V_{OUT} = 3.3V$		8		mV/A
V_{OUT} Undervoltage Trip Level to Cause HICCUP	$V_{OUT-HICF}$	$V_{SS} > 0.95V$ (soft-start is done)	68.5	71.14	73.5	%
HICCUP Timeout				32768		Cycles

Electrical Characteristics (continued)

($V_{IN} = +24V$, $V_{GND} = V_{PGND} = 0V$, $C_{IN} = 2.2\mu F$, $V_{EN} = 1.5V$, $C_{OUT} = 22\mu F$, $V_{FB} = V_{OUT}$, $SS = COMP = \overline{RESET} =$ unconnected. $T_A = T_J = -40^\circ C$ to $+125^\circ C$, unless otherwise noted. Typical values are at $T_A = +25^\circ C$. All voltages are referenced to GND, unless otherwise noted.) (Note 2)

PARAMETER	SYMBOL	CONDITIONS	MIN	TYP	MAX	UNITS
CURRENT LIMIT						
Average Current-Limit Threshold	$I_{AVG-LIMIT}$			1.5		A
Valley Current-Limit Threshold	$I_{VALLEY-LIMIT}$		0.56	0.65	0.74	
OSCILLATOR						
Switching Frequency	f_{SW}	$V_{FB} > V_{OUT-HICF}$	500	540	580	kHz
		$V_{FB} < V_{OUT-HICF}$	250	270	290	
Minimum On-Time	t_{ON_MIN}			75	120	ns
RESET (\overline{RESET})						
\overline{RESET} Output Level Low		$I_{\overline{RESET}} = 1mA$			0.04	V
\overline{RESET} Output Leakage Current High		$V_{FB} = 1V$			0.45	μA
V_{OUT} Threshold for \overline{RESET} Assertion	$V_{OUT-OKF}$	V_{FB} falling	90.5	92.5	94.5	%
V_{OUT} Threshold for \overline{RESET} De-assertion	$V_{OUT-OKR}$	V_{FB} rising	93.5	95.5	97.5	%
\overline{RESET} Deassertion Delay after FB Reaches 95% Regulation				1024		Cycles
THERMAL SHUTDOWN						
Thermal-Shutdown Threshold		Temperature rising		165		$^\circ C$
Thermal-Shutdown Hysteresis				10		$^\circ C$

Note 2: All limits are 100% tested at $T_A = +25^\circ C$. Maximum and minimum limits are guaranteed by design and characterization over temperature.

Typical Operating Characteristics

($V_{IN} = 4.5V$ to $60V$, $V_{OUT} = 0.9$ to $5.0V$, $I_{OUT} = 0A$ to $1A$, $T_A = +25^\circ C$, unless otherwise noted.)

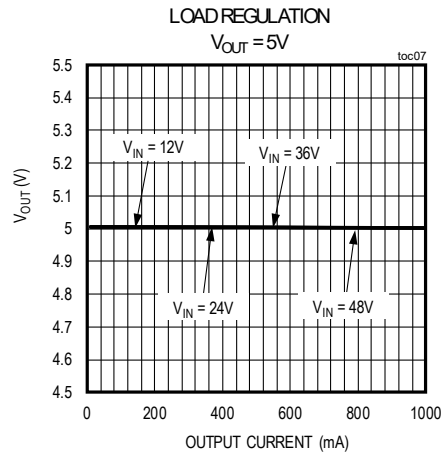
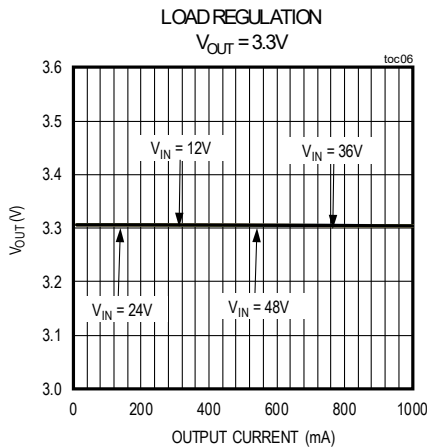
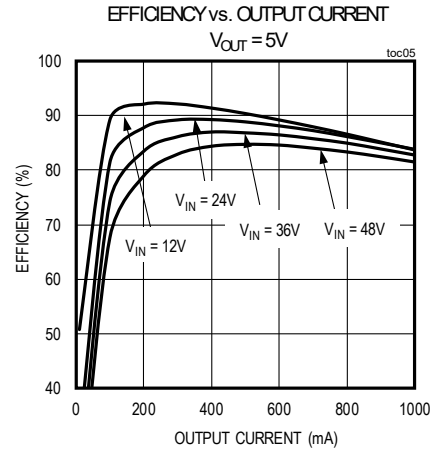
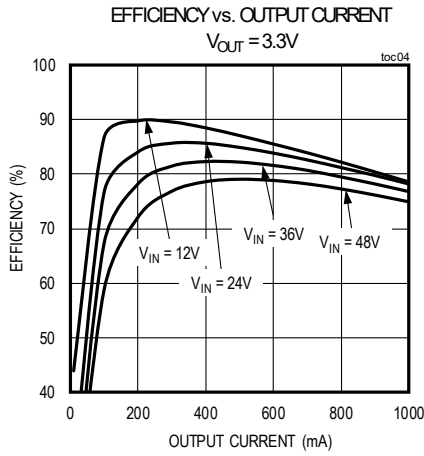
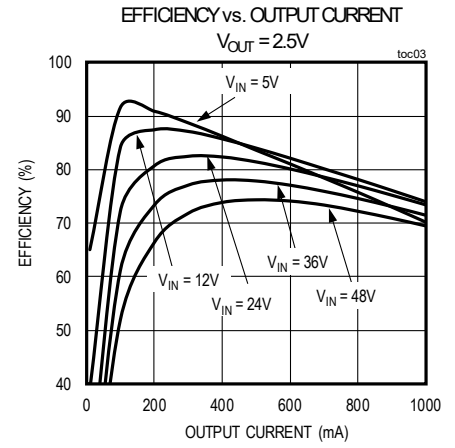
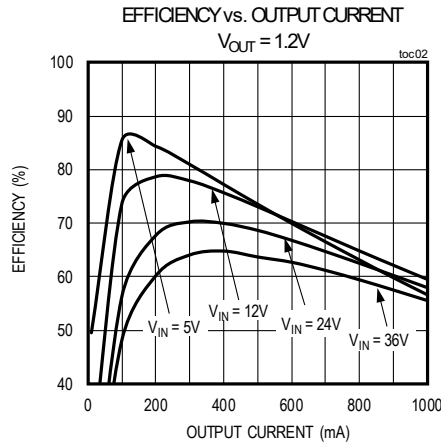
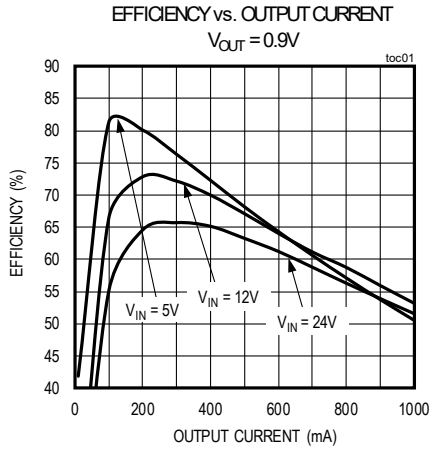

Typical Operating Characteristics (continued)

(V_{IN} = 4.5V to 60V, V_{OUT} = 0.9 to 5.0V, I_{OUT} = 0A to 1A, T_A = +25°C, unless otherwise noted.)

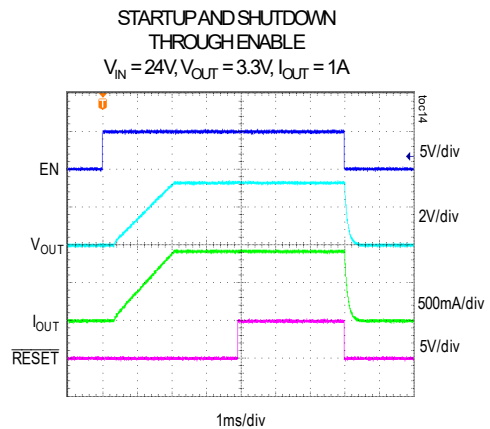
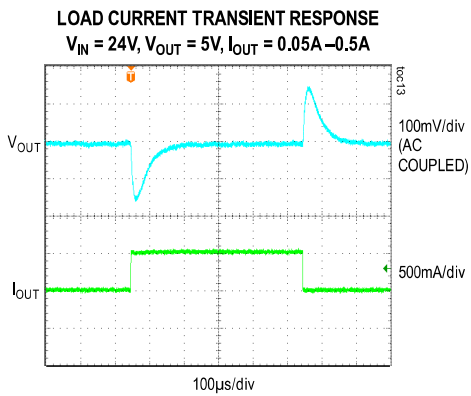
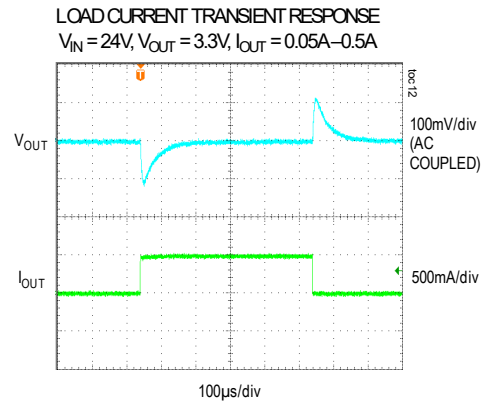
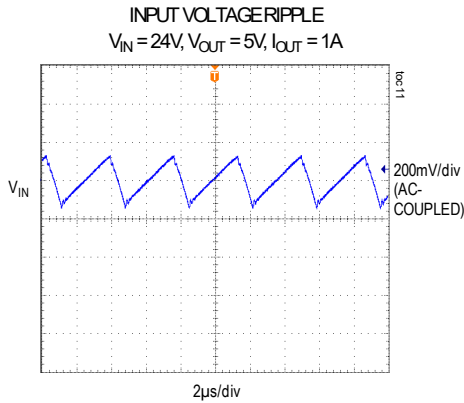
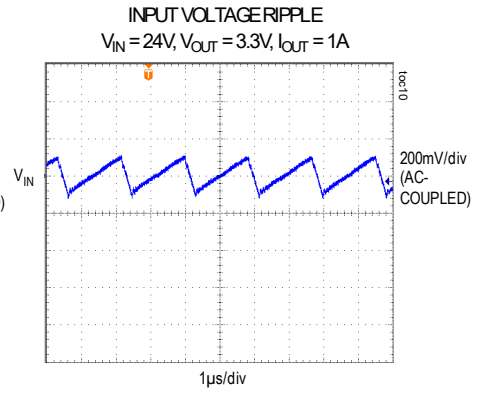
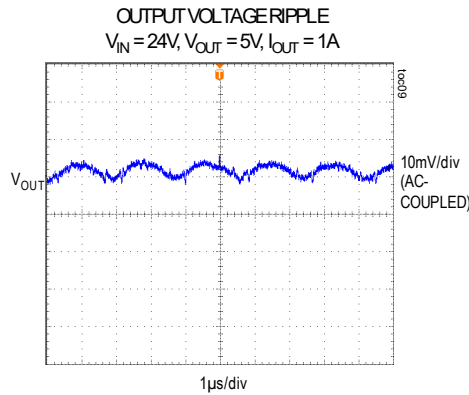
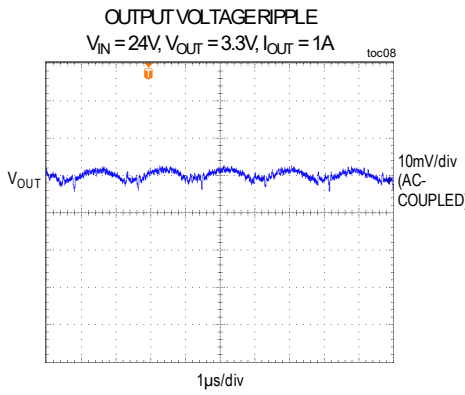

Typical Operating Characteristics (continued)

($V_{IN} = 4.5V$ to $60V$, $V_{OUT} = 0.9$ to $5.0V$, $I_{OUT} = 0A$ to $1A$, $T_A = +25^\circ C$, unless otherwise noted.)

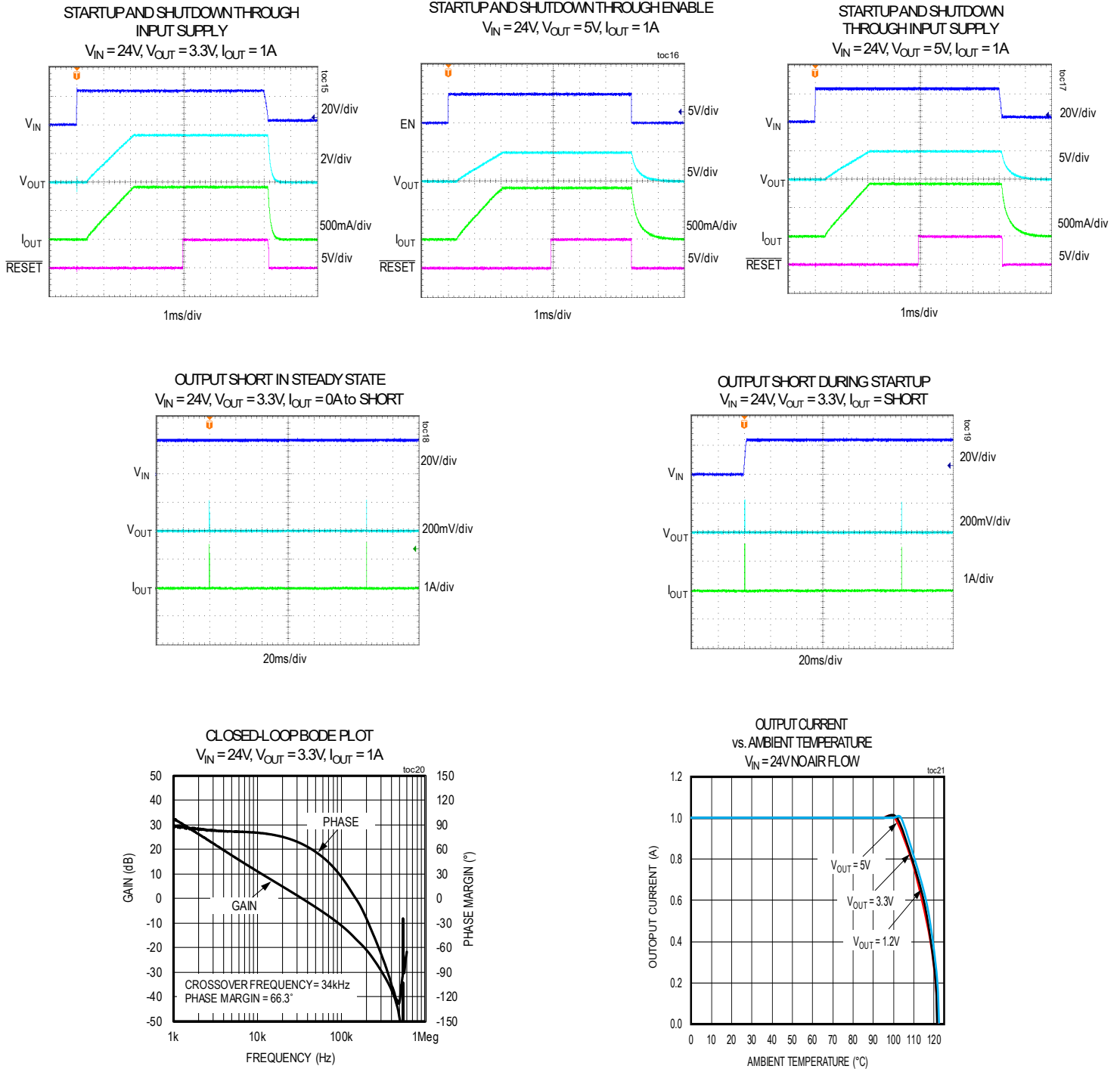

Pin Configuration

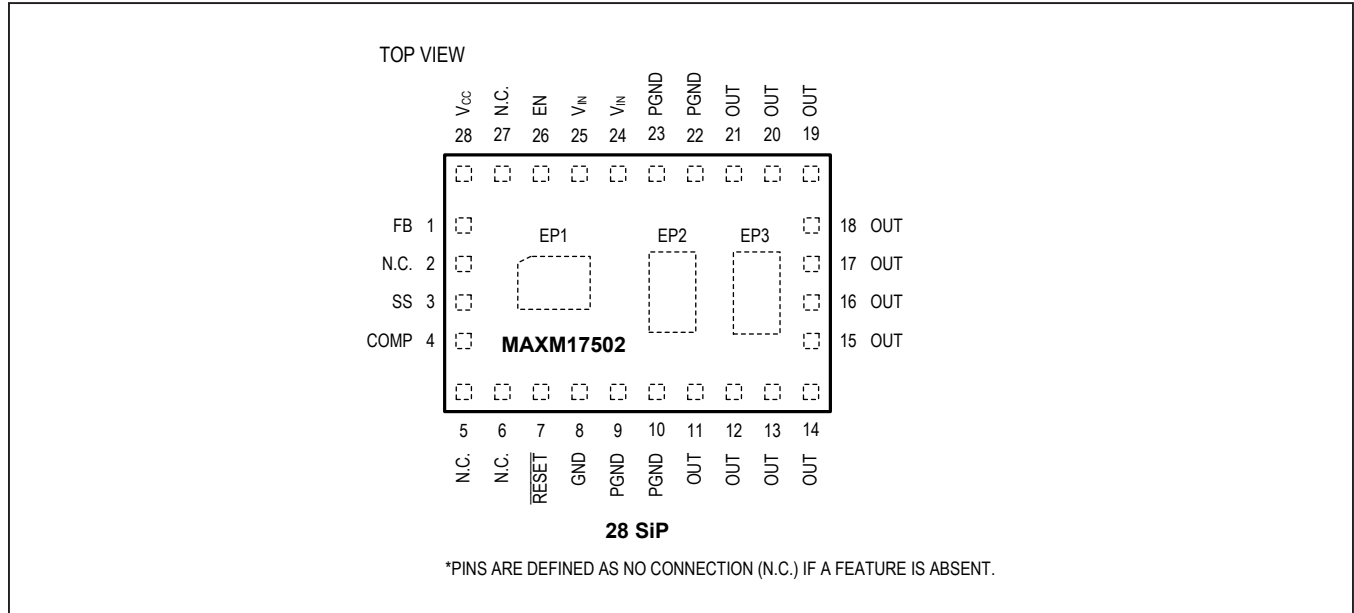

Pin Description

PIN	NAME	FUNCTION
1	FB	Feedback Input. Connect FB to the center of the resistive divider between OUT and GND.
2, 5, 6, 27	N.C.	No Connection. Leave this pin unconnected.
3	SS	Soft-Start Input. Default soft-start time is 1.8ms with internal soft-start capacitance of 10nF. Connect additional capacitor from SS to GND to increase the soft-start time.
4	COMP	Leave Unconnected.
7	RESET	Open-Drain RESET Output. It is driven low if FB drops below 92.5% of its set value. RESET goes high 1024 clock cycles after FB rises above 95.5% of its set value. RESET is valid when the device is enabled and VIN is above 4.5V.
8	GND	Analog Ground. Connect to PGND at a single point.
9, 10, 22, 23	PGND	Power Ground. Connect PGND externally to the power ground plane.
11–21	OUT	Regulator Output Pin. Connect a capacitor from OUT to PGND. See PCB Layout Guidelines section for more connection details.
24, 25	VIN	Power-Supply Input. The input supply range is from 4.5V to 60V.
26	EN	Enable/Undervoltage Lockout Input. Drive EN high to enable the output voltage. Connect to the center of the resistive divider between VIN and GND to set the input voltage (undervoltage threshold) at which the device turns on. Pull up to VIN for always on.
28	VCC	5V LDO Output
EP1	GND	Exposed Pad 1. Connect this pad to the GND plane and copper area of 1in x 1in for cooling.
EP2	LX	Exposed Pad 2. Connect this pad to the PCB for better thermal performance, but do not connect to any other node. Minimize area of copper island
EP3	OUT	Exposed Pad 3. Connect this pad to the OUT pins and copper area of 1in x 1in.

Functional Diagram

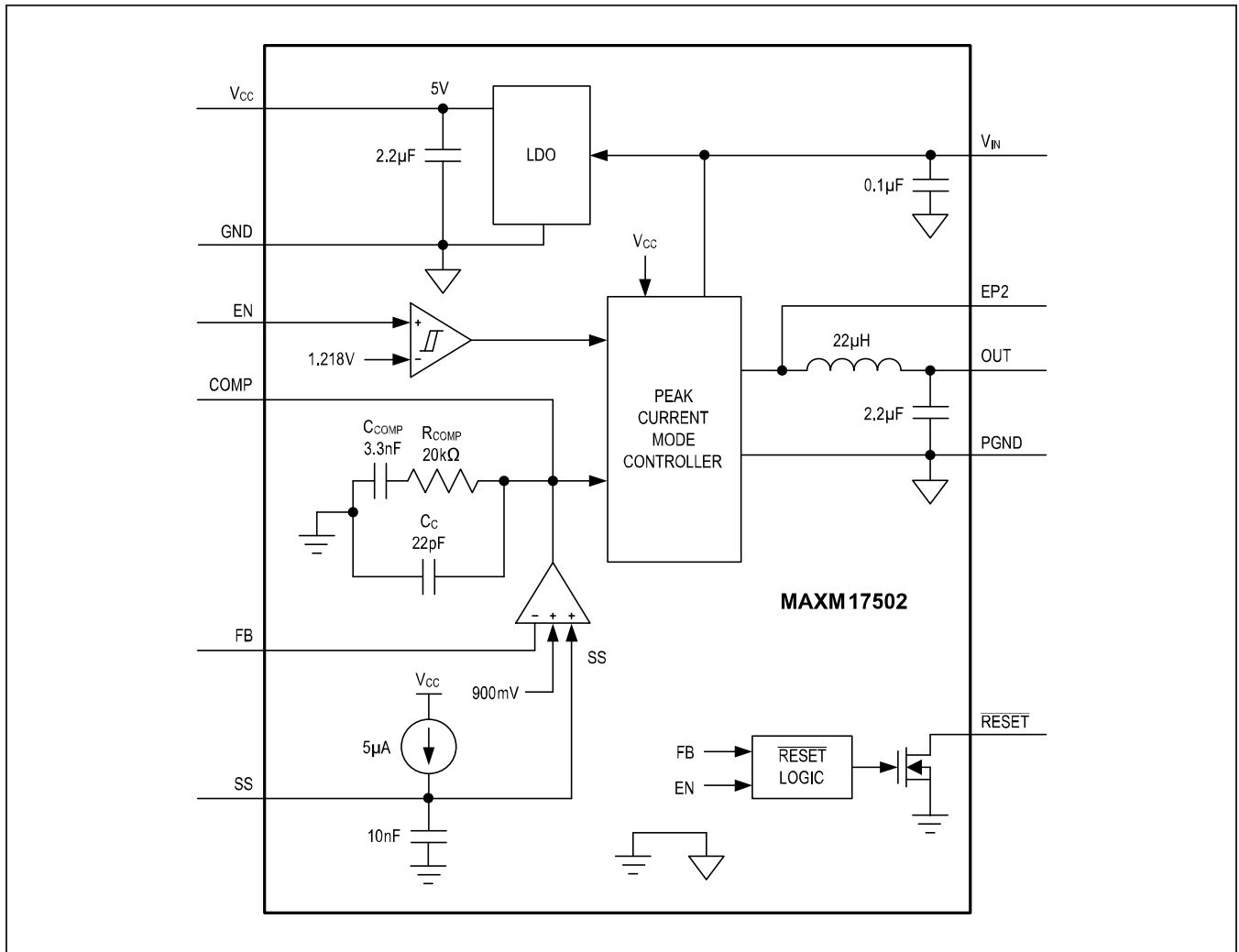

Design Procedure

Setting the Output Voltage

The MAXM17502 supports an adjustable output voltage range of 0.9V to 5.0V by using a resistive feedback divider from OUT to FB. The adjustable output voltages can be calculated by following the procedure to choose the resistive voltage-divider values:

Select the parallel combination of R1 and R2, R_P to be less than 15k Ω . Once R_P is selected, calculate R1 as:

$$R1 = \frac{R_P \times V_{OUT}}{0.9}$$

Calculate resistor R2 FB to GND as follows:

$$R2 = \frac{R1 \times 0.9}{(V_{OUT} - 0.9)}$$

where R2 is in k Ω .

Input Voltage Range

The maximum operating input voltage is determined by the minimum controllable on-time and the minimum operating input voltage is determined by the maximum duty cycle and circuit voltage drops. The minimum and maximum operating input voltages for a given output voltage should be calculated as:

$$V_{IN(MIN)} = \frac{V_{OUT} + (I_{OUT(MAX)} \times 1.013)}{D_{MAX}} + (I_{OUT(MAX)} \times 0.73)$$

$$V_{IN(MAX)} = \frac{V_{OUT}}{f_{SW(MAX)} \times t_{ON(MIN)}}$$

where V_{OUT} is the steady-state output voltage, $I_{OUT(MAX)}$ is the maximum load current, $f_{SW(MAX)}$ is the switching frequency (maximum), and $t_{ON(MIN)}$ is the worst-case minimum switch on-time.

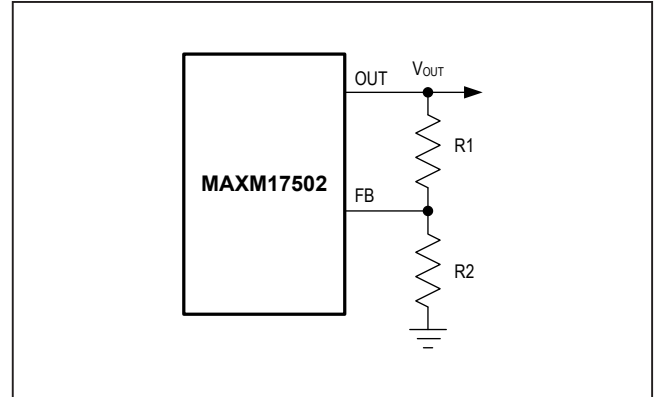

Figure 1: Adjusting Output Voltage

Input Capacitor Selection

The input capacitor serves to reduce the current peaks drawn from the input power supply and reducing switching noise to the IC. The input capacitor values in [Table 1](#) are the minimum recommended values for desired input and output voltages. Applying capacitor values larger than those indicated in [Table 1](#) are acceptable. For further operating conditions, the total input capacitance must be equal to or greater than the value given by the following equation to keep the input-voltage ripple within specifications and minimize the high-frequency ripple current being fed back to the input source:

$$C_{IN} = \frac{(I_{IN_AVG}) \times (1-D)}{(\Delta V_{IN}) \times f_{SW}}$$

where:

I_{IN_AVG} is the average input current given by:

$$I_{IN_AVG} = \frac{P_{OUT}}{\eta \times V_{IN}}$$

D is the operating duty cycle, which is approximately equal to V_{OUT}/V_{IN}

ΔV_{IN} is the required input voltage ripple

f_{SW} is the operating switching frequency

P_{OUT} is the output power, which is equal to $V_{OUT} \times I_{OUT}$

η is the efficiency

The input capacitor must meet the ripple current requirement imposed by the switching currents. The RMS input ripple current is given by:

$$I_{RMS} = I_{OUT} \times \sqrt{D \times (1-D)}$$

The worst-case RMS current requirement occurs when operating with $D = 0.5$. At this point, the above equation simplifies to $I_{RMS} = 0.5 \times I_{OUT}$.

For the MAXM17502 system (IN) supply, ceramic capacitors are preferred due to their resilience to inrush surge currents typical of systems and their low parasitic inductance. These attributes help reduce the high-frequency ringing on the IN supply when the internal MOSFETs are turned off. Choose an input capacitor that exhibits less than +10°C temperature rise at the RMS input current for optimal circuit longevity.

Output Capacitor Selection

The X7R ceramic output capacitors are preferred due to their stability over temperature in industrial applications. The output capacitor is usually sized to support a step load of 50% of the maximum output current in the application, so the output voltage deviation is contained to $\pm 3\%$ of the output voltage change. For adjustable output voltages, the output capacitance value is given by the following equation:

$$C_{OUT} = \frac{1}{2} \times \frac{I_{STEP} \times t_{RESPONSE}}{\Delta V_{OUT}}$$

$$t_{RESPONSE} \cong \frac{0.33}{f_C} + \frac{1}{f_{SW}}$$

where I_{STEP} is the load current step, $t_{RESPONSE}$ is the response time of the controller, ΔV_{OUT} is the allowable output voltage deviation during load transient, f_C is the target closed-loop crossover frequency, and f_{SW} is the switching frequency. Select f_C to be 1/12th of f_{SW} . Consider DC bias and aging effects while selecting the output capacitor.

Table 1. Component Selection Table

V_{IN} (V)	V_{OUT} (V)	C_{IN}	C_{OUT}	R_U (k Ω)	R_B (k Ω)
4.5 to 13	0.9	1 x 2.2 μ F 1206 100V	2 x 47 μ F 1210 6.3V	13	Open
4.5 to 15	1	1 x 2.2 μ F 1206 100V	2 x 47 μ F 1210 6.3V	14.3	130
4.5 to 18	1.2	1 x 2.2 μ F 1206 100V	3 x 22 μ F 1206 6.3V	17.4	52.3
4.5 to 23	1.5	1 x 2.2 μ F 1206 100V	3 x 22 μ F 1206 6.3V	21.5	32.4
4.5 to 27	1.8	1 x 2.2 μ F 1206 100V	3 x 22 μ F 1206 6.3V	26.1	26.1
6 to 38	2.5	1 x 2.2 μ F 1206 100V	1 x 47 μ F 1210 6.3V	36.5	20.5
8 to 50	3.3	1 x 2.2 μ F 1206 100V	1 x 22 μ F 1206 6.3V	47.5	17.8
12 to 60	5	1 x 2.2 μ F 1206 100V	1 x 22 μ F 1206 6.3V	75	16.5

Soft-Start Capacitor Selection

The device provides a default 1.8ms soft-start time to reduce inrush current during start-up. The soft-start time can be increased by connecting an external capacitor (C_{SS}) from the SS pin to GND. The value of the additional soft-start capacitor is calculated from the desired soft-start time as follows:

$$C_{SS} = (5.55 \times t_{SS} - 10)$$

where t_{SS} is in ms and C_{SS} is in nF.

Detailed Description

The MAXM17502 is a complete step-down DC-DC power supply to deliver up to 1000mA output current. The device contains switch mode power supply controller, dual n-channel MOSFET power switches and a fully shielded inductor as well as internal compensation. The device provides a programmable output voltage to regulate up to 5V through external resistor dividers from an input voltage range of 4.5V to 60V. The device uses a 540kHz switching frequency to reduce sizes of input and output capacitors. The [Functional Diagram](#) illustrates the complete internal block diagram of the MAXM17502 power module.

Input Undervoltage-Lockout Level

The device offers an adjustable input undervoltage-lockout level to set the voltage at which the device turns on by a resistive divider R_3 and R_4 connecting from IN to GND. With R_3 selected as 3.3M Ω , R_4 can be calculated as:

$$R_4 \approx \frac{3.3 \times 1218}{(V_{INU} - 1.218)}$$

where R_4 is in k Ω and V_{INU} is the voltage at which the device is required to turn on the device. Ensure that V_{INU} is high enough to support the V_{OUT} .

RESET Output

The device includes a $\overline{\text{RESET}}$ comparator to monitor the output for undervoltage and overvoltage conditions. The open-drain $\overline{\text{RESET}}$ output requires an external pull up resistor from 10k Ω to 100k Ω to V_{CC} pin or a voltage source not to exceed absolute maximum rating of 6V. $\overline{\text{RESET}}$ goes high impedance after the regulator output increases above 95.5% of the designed nominal regulated voltage. $\overline{\text{RESET}}$ goes low when the regulator output voltage drops below 92.5% of the nominal regulated voltage. $\overline{\text{RESET}}$ also goes low during thermal shutdown.

Thermal Fault Protection

The device features a thermal-fault protection circuit. When the junction temperature rises above +165°C (typ), a thermal sensor activates the fault latch, pulls down the $\overline{\text{RESET}}$ output, and shuts down the regulator. The thermal sensor restarts the controllers after the junction temperature cools by 10°C (typ). The soft-start resets during thermal shutdown.

Power Dissipation

The MAXM17502 output current needs to be derated if the module needs to be operated in high ambient temperature. The derating curves given in the [Typical Operating Characteristics](#) can be used as a guide.

The maximum allowable power losses can be calculated using the following equation:

$$P_{\text{DMAX}} = \frac{T_{\text{JMAX}} - T_{\text{A}}}{\theta_{\text{JA}}}$$

where:

P_{DMAX} is the maximum allowed power losses with maximum allowed Junction temperature

T_{JMAX} is the maximum allowed junction temperature (+125°C)

T_{A} is operating ambient temperature

θ_{JA} is the junction to ambient thermal resistance

PCB Layout Guidelines

For a sample layout, refer to the MAXM17502 evaluation kit layouts available at www.maximintegrated.com. Use the following guidelines for good PCB layout:

- All connections carrying pulsed currents must be very short and as wide as possible. The loop area of these connections must be made very small to reduce stray inductance and radiated EMI.
- Keep the input capacitors as close as possible to the IN and PGND pins.
- Keep the output capacitors as close as possible to the OUT and PGND pins.
- Keep the resistive feedback dividers as close as possible to the FB pin.
- Connect all of the PGND connections to as large as copper plane area as possible on the top layer.
- Connect EP1 to PGND and GND planes on top layer.
- Use multiple vias to connect internal PGND planes to the top layer PGND plane.
- Do not keep any solder mask on EP1, EP2, and EP3 on bottom layer. Keeping a solder mask on exposed pads decreases the heat dissipating capability.
- Keep the power traces and load connections short. This practice is essential for high efficiency.
- Using thick copper PCBs (2oz vs. 1oz) can enhance full load efficiency. Correctly routing PCB traces is a difficult task that must be approached in terms of fractions of centimeters, where a single m Ω of excess trace resistance causes a measurable efficiency penalty.

Layout Recommendation

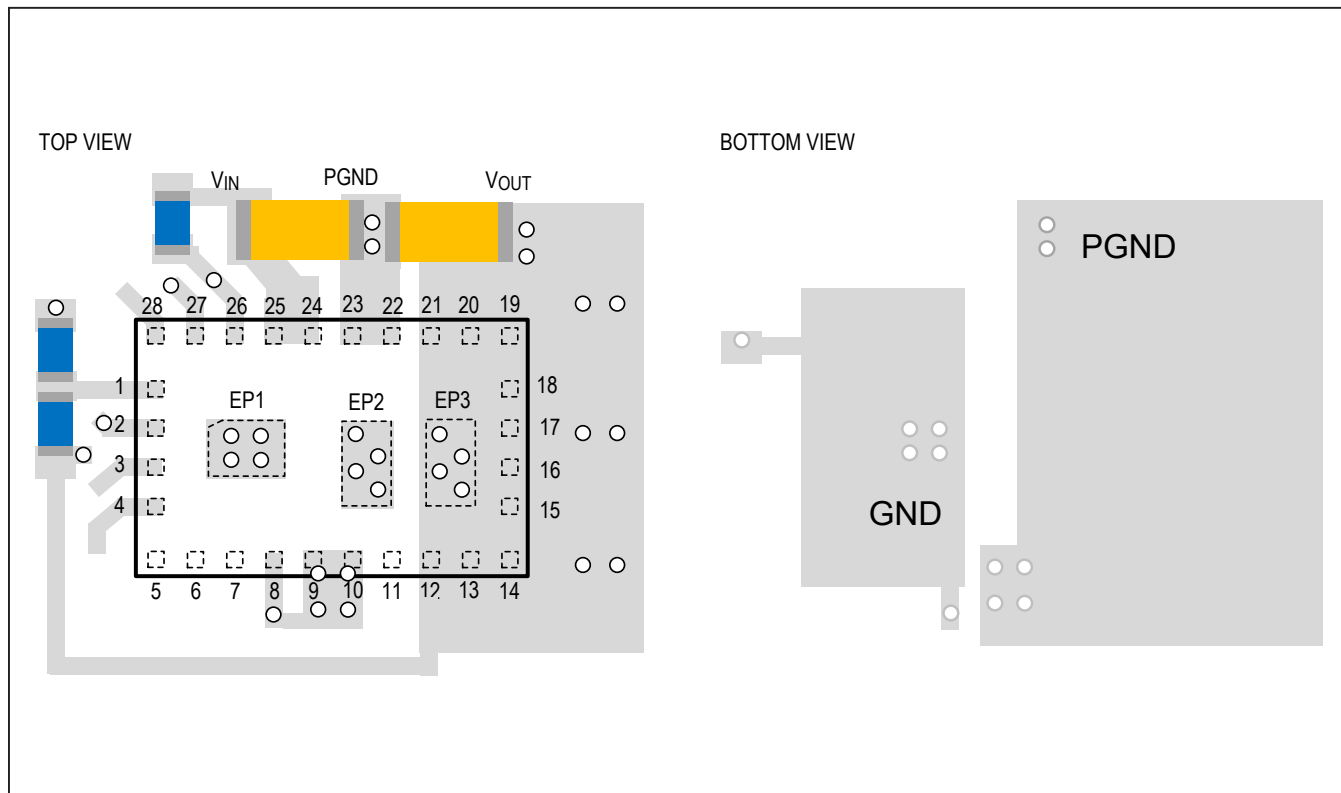

Typical Application Circuit

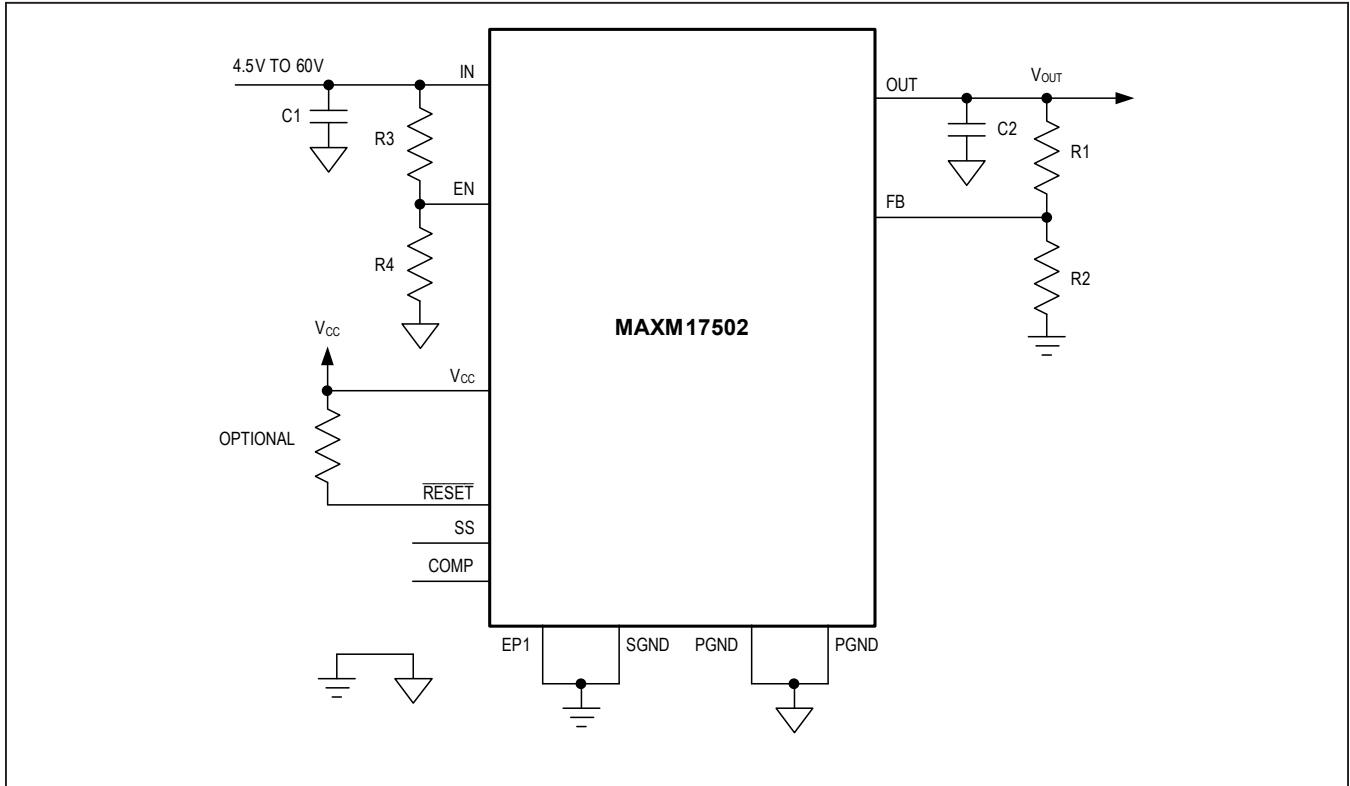

Ordering Information

PART	TEMP RANGE	PIN-PACKAGE
MAXM17502ALI#	-40°C to +125°C	28 SiP
MAXM17502ALI#T	-40°C to +125°C	28 SiP

#Denotes a RoHS-compliant device that may include lead(Pb) that is exempt under the RoHS requirements.

T = Tape and reel.

Chip Information

PROCESS: BiCMOS

MAXM17502

1A, 60V High-Efficiency, DC-DC Step-Down
Power Module with Integrated Inductor

Revision History

REVISION NUMBER	REVISION DATE	DESCRIPTION	PAGES CHANGED
0	5/17	Initial release	—
1	11/17	Updated <i>Absolute Maximum Ratings</i> section, Table 1, and <i>Layout Recommendation</i> diagram	2, 11, 13
2	5/19	Updated the part number to MAXM17502ALI# and MAXM17502ALI#T in the <i>Ordering Information</i> table	14

For pricing, delivery, and ordering information, please contact Maxim Direct at 1-888-629-4642, or visit Maxim Integrated's website at www.maximintegrated.com.

Maxim Integrated cannot assume responsibility for use of any circuitry other than circuitry entirely embodied in a Maxim Integrated product. No circuit patent licenses are implied. Maxim Integrated reserves the right to change the circuitry and specifications without notice at any time. The parametric values (min and max limits) shown in the *Electrical Characteristics* table are guaranteed. Other parametric values quoted in this data sheet are provided for guidance.