

EVAL-FFXMR20KM1HDR

Evaluation board description and getting started guide

User guide

UG-2022-14

About this document

The purpose of this board is to enable the evaluation of the FF6MR20KM1H, FF4MR20KM1H and FF3MR20KM1H CoolSiC™ MOSFET modules. The evaluation board allows users to evaluate the device performance via double-pulse measurements.

Scope and purpose

The properties of this board are described in the design features' chapter of this document. The remaining sections provide information to enable designers to copy, modify and qualify the design for production, according to the customer-specific requirements.

Environmental regulations have been considered in the design of the EVAL-FFXMR20KM1HDR board. Components qualified for a lead-free, reflow soldering process have been selected. The design has been tested as described in this document, but not qualified regarding manufacturing and operation over the whole operating temperature range or lifetime.

Intended audience

This document is intended for engineers who want to document and evaluate the switching performance of Infineon CoolSiC™ 62 mm 2kV modules.

Evaluation board

This board will be used during design-in, for evaluation and measurement of characteristics, and proof of data sheet specifications.

Note: PCB and auxiliary circuits are NOT optimized for final customer design.



Important notice

Important notice

“Evaluation Boards and Reference Boards” shall mean products embedded on a printed circuit board (PCB) for demonstration and/or evaluation purposes, which include, without limitation, demonstration, reference and evaluation boards, kits and design (collectively referred to as “Reference Board”).

Environmental conditions have been considered in the design of the Evaluation Boards and Reference Boards provided by Infineon Technologies. The design of the Evaluation Boards and Reference Boards has been tested by Infineon Technologies only as described in this document. The design is not qualified in terms of safety requirements, manufacturing and operation over the entire operating temperature range or lifetime.

The Evaluation Boards and Reference Boards provided by Infineon Technologies are subject to functional testing only under typical load conditions. Evaluation Boards and Reference Boards are not subject to the same procedures as regular products regarding returned material analysis (RMA), process change notification (PCN) and product discontinuation (PD).

Evaluation Boards and Reference Boards are not commercialized products, and are solely intended for evaluation and testing purposes. In particular, they shall not be used for reliability testing or production. The Evaluation Boards and Reference Boards may therefore not comply with CE or similar standards (including but not limited to the EMC Directive 2004/EC/108 and the EMC Act) and may not fulfill other requirements of the country in which they are operated by the customer. The customer shall ensure that all Evaluation Boards and Reference Boards will be handled in a way which is compliant with the relevant requirements and standards of the country in which they are operated.

The Evaluation Boards and Reference Boards as well as the information provided in this document are addressed only to qualified and skilled technical staff, for laboratory usage, and shall be used and managed according to the terms and conditions set forth in this document and in other related documentation supplied with the respective Evaluation Board or Reference Board.

It is the responsibility of the customer’s technical departments to evaluate the suitability of the Evaluation Boards and Reference Boards for the intended application, and to evaluate the completeness and correctness of the information provided in this document with respect to such application.

The customer is obliged to ensure that the use of the Evaluation Boards and Reference Boards does not cause any harm to persons or third party property.

The Evaluation Boards and Reference Boards and any information in this document is provided "as is" and Infineon Technologies disclaims any warranties, express or implied, including but not limited to warranties of non-infringement of third party rights and implied warranties of fitness for any purpose, or for merchantability.

Infineon Technologies shall not be responsible for any damages resulting from the use of the Evaluation Boards and Reference Boards and/or from any information provided in this document. The customer is obliged to defend, indemnify and hold Infineon Technologies harmless from and against any claims or damages arising out of or resulting from any use thereof.

Infineon Technologies reserves the right to modify this document and/or any information provided herein at any time without further notice.

Safety precautions

Safety precautions

Please note the following warnings regarding the hazards associated with development systems.

Table 1 Safety precautions





	<p>Warning: The DC link potential of this board is up to 1500 VDC. When measuring voltage waveforms by oscilloscope, high voltage differential probes must be used. Failure to do so may result in personal injury or death.</p>
	<p>Warning: The evaluation or reference board is connected to the grid input during testing. Hence, high-voltage differential probes must be used when measuring voltage waveforms by oscilloscope. Failure to do so may result in personal injury or death. Darkened display LEDs are not an indication that capacitors have discharged to safe voltage levels.</p>
	<p>Caution: Only personnel familiar with the drive, power electronics and associated machinery should plan, install, commission and subsequently service the system. Failure to comply may result in personal injury and/or equipment damage.</p>
	<p>Caution: The evaluation or reference board contains parts and assemblies sensitive to electrostatic discharge (ESD). Electrostatic control precautions are required when installing, testing, servicing or repairing the assembly. Component damage may result if ESD control procedures are not followed. If you are not familiar with electrostatic control procedures, refer to the applicable ESD protection handbooks and guidelines.</p>
	<p>Caution: The evaluation or reference board is shipped with packing materials that need to be removed prior to installation. Failure to remove all packing materials that are unnecessary for system installation may result in overheating or abnormal operating conditions.</p>

Table of contents

Table of contents

About this document	1
Important notice	2
Safety precautions	3
Table of contents	4
1 The evaluation board at a glance	5
1.1 Delivery content	6
1.2 Block diagram.....	6
1.3 Main features	7
1.4 Typical applications	8
1.5 Board parameters and technical data.....	8
2 System and functional description	9
2.1 Commissioning.....	9
2.2 Description of the functional blocks.....	10
2.2.1 Prerequisites	11
2.2.2 2.1.2 EiceDRIVER™ 1ED38x0 DCT software installation process.....	11
2.2.3 Evaluation of the EVAL-FFXMR20KM1HDR board with another microcontroller	11
2.2.4 Power-up sequence	11
2.3 Introduction to EiceDRIVER™ 1ED38x0 DCT	13
3 System design	15
3.1 Schematics	15
3.2 Layout	15
3.3 Bill of material	18
3.4 Connector details	18
4 System performance	19
4.1 Test setup	19
4.2 Switching performance.....	20
4.2.1 MOSFET switch-on behavior.....	20
4.2.2 MOSFET switch-off behavior.....	21
5 References and appendices	22
5.1 References	22
5.2 Additional information.....	22
Revision history	23

1 The evaluation board at a glance

The evaluation board EVAL-FFXMR20KM1HDR allows the customer to begin initial characterization measurements very quickly. Due to the usage of the EiceDRIVER™ 1ED38x0Mc12M and its flexible parameter setting options via I2C-BUS the EVAL-FFXMR20KM1HDR can be quickly adapted to different applications (like DC/DC-converter, Solar applications, UPS systems, Solid state transformer, Drives and others) without changing the hardware. This flexible parameter settings are provided by 27 configuration registers accessible via I2C. These configuration options influence many threshold and timing parameters to optimize the circuit for its intended application. In addition to the flexible parameter setting options via I2C-BUS, the EiceDRIVER™ 1ED38x0Mc12M contains 16 status registers. These can also be read out via the I2C-BUS and can therefore provide information about various states of the driver stage. This is the so-called condition monitoring and can serve as enabler, if wanted, for predictive maintenance. For more information we refer to the EiceDRIVER™ 1ED38x0Mc12M reference manual here.

Without the need to modify external components during evaluation, the whole process becomes much faster than before and enables, what we call, rapid-prototyping.

Another important feature of the EiceDRIVER™ 1ED38x0Mc12M is the soft-off behavior in the event of a worst case error, the short circuit. The driver has an integrated DESAT module which switches off the driver in a short circuit event. Due to the high currents that occur in these event and a simultaneous hard switch-off, very high peak voltages can occur due to parasitic inductances. These can reduce the life-time of the power switch or can destroy the whole application. With soft-off behavior, only a part of the maximum gate current is used for switch-off. As a result, the power switch turns off more slowly and the peak voltage can be limited significantly. Both the soft-off behavior and the permitted current levels (within certain limits) can be set via a configuration register.

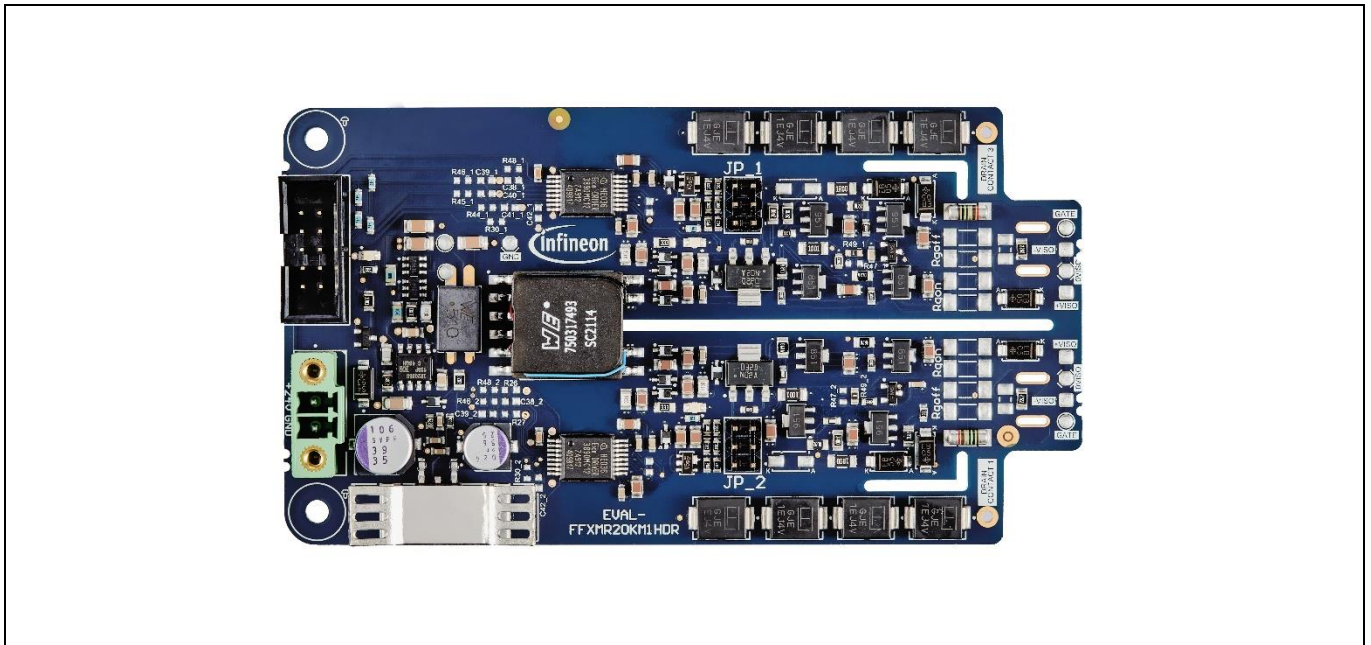

Figure 1 Realistic view of the EVAL-FFXMR20KM1HDR

The evaluation board at a glance

1.1 Delivery content

The board appears as shown in Figure 1. For a complete testing of the board some components must be ordered in addition as shown in Figure 2. The Infineon EVAL-1ED38X0DCT microcontroller board ideally be used in order to be able to configure all the parameters in an easy and fast manner. On the power side, any 62mm 2kV half bridge module can be used for evaluation purpose.

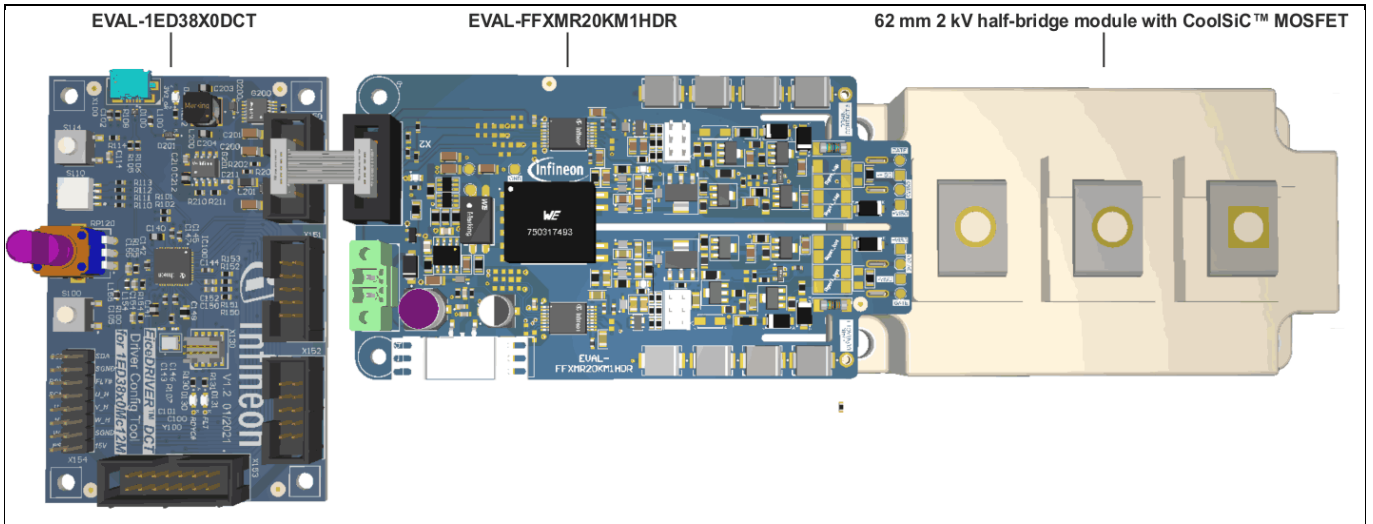

Figure 2 Complete evaluation system consisting of the 62mm module, the EVAL-FFXMR20KM1HDR as the driver stage and the EVAL-1ED38X0DCT as the control and configuration stage.

1.2 Block diagram

The block diagram of the complete evaluation system is shown in Figure 3. Please note the individual building blocks as mentioned in chapter 1.1.

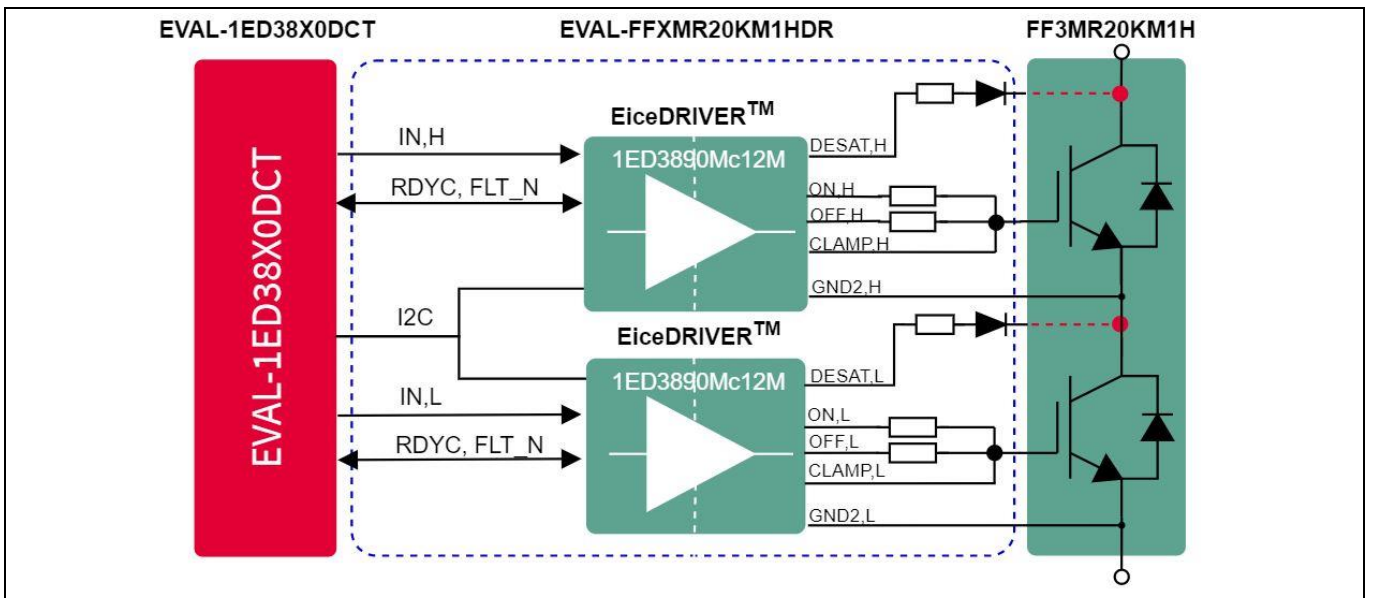

Figure 3 Block diagram of the EVAL-FFXMR20KM1HDR

The evaluation board at a glance

1.3 Main features

The EVAL-FFXMR20KM1HDR is an evaluation board for the EiceDRIVER™ 1ED38x0Mc12M gate drivers ICs to be used together with our 62 mm 2 kV half-bridge module with CoolSiC™ MOSFET. The board is designed for easy measurement and configuration of the gate driver and module parameters.

The main features of the board and gate driver include:

- Half-bridge driver for 62 mm, 2kV modules with CoolSiC™ Trench MOSFET technology
- Driver IC 1ED3890MC12M or 1ED3890MU12M (X3 digital) with I²C bus for parameter adjustment
- Electrically and mechanically suitable for 62 mm, 2kV modules with CoolSiC™ Trench MOSFET technology
- Negative voltage adjustment from -5 V to 0 V
- Positive voltage adjustment for high switching frequencies
- Proper PCB design to limit the PCB heating during operation
- 40 V absolute maximum output supply voltage
- Booster stage to increase the sourcing and sinking gate current capability
- Separate source and sink output for optimized gate driving
- Adjustable clamp/clamp driver/ADC pin
- I²C bus for parameter adjustment, state and fault feedback, ADC measurements, and condition monitoring
- Two precise $V_{CE(sat)}$ detection (DESAT²) circuits with fault output, adjustable leading-edge blanking time and individually adjustable trigger voltages, filter times
- Two-level turn-off (TLTO) with adjustable slopes, plateau time, and plateau level
- Selectable turn-off: hard turn-off and two-level turn-off
- Adjustable soft turn-off after desaturation detection
- Adjustable input filter
- Hardware undervoltage lockout (UVLO) protection with hysteresis for the input side
- Adjustable hardware UVLO with hysteresis for IGBTs and MOSFETs on both VCC2 and VEE2 rails with active shutdown
- Adjustable software UVLO for accurate supply voltage monitoring on both VCC2 and VEE2 rails
- ADC measurement of internal parameters: supply voltages and internal temperature
- Pin state reporting via I²C and fault
- Internal counters for DESAT or UVLO events
- Gate driver operation at high ambient temperature up to 125°C with over-temperature shutdown at 160°C ($\pm 10^\circ\text{C}$)
- Tight IC-to-IC propagation delay matching ($t_{PDD,max} = 30 \text{ ns}$)
- Undervoltage lockout protection with hysteresis for input and output side with active shutdown
- High common-mode transient immunity CMTI = 200 kV/ μs
- Small space-saving DSO-16 fine-pitch package with large creepage distance (>8 mm)
- Gate driver safety certification:
 - UL 1577 recognized (planned) with $V_{ISO,test} = 6840 \text{ V (rms)}$ for 1 s, $V_{ISO} = 5700 \text{ V (rms)}$ for 60 s
 - IEC 60747-17/VDE 0884-11 approval (planned) with $V_{IORM} = 1.767 \text{ kV (peak, reinforced)}$

The evaluation board at a glance

1.4 Typical applications

- High frequency switching applications
- DC/DC converter
- Solar application
- UPS systems
- Solid-state transformer

1.5 Board parameters and technical data

The EVAL-FFXMR20KM1HDR is a gate driver board for driving 62 mm, 2kV modules with our latest CoolSiC™ Trench MOSFET technology in a half-bridge configuration. It shows the reliable and fast controllability of such devices using the 1ED3890MC12M or 1ED3890MU12M (X3 digital) enhanced driver together with a booster stage to increase the driver output power.

The EVAL-FFXMR20KM1HDR operates with a supply voltage of up to 24 V. It generates an output voltage of up to 18 V at the gate terminals, depending on the load conditions. To switch the device, a pulse width modulation (PWM) for both, the top and the bottom side need to be applied at the connector input. A negative signal at the enable pin turns off the device. A detailed description of the functional blocks is shown in the next chapter.

Table 2 Parameter

Parameter	Symbol	Conditions	Value	Unit
Power supply input voltage	V _{in}	Referenced to SGND	+24	V
Primary side supply voltage	VCC1	Referenced to SGND. Not to be used with EiceDRIVER™ Eval-1ED38x0DCT	-0.3 ... 6.5	V
I ² C Serial Clock Line	SCL	Referenced to SGND	-0.3 ... 6.5	V
I ² C Serial Data Line	SDA	Referenced to SGND	-0.3 ... 6.5	V
Ready state output/ fault-clear input and fault-off input	RDYC	Input/Output digital signal. Referenced to SGND	-0.3 ... 6.5	V
Fault output/ fault-off input	FLT#	Input/Output Digital signal. Referenced to SGND	-0.3 ... 6.5	V
PWM input for the high-side gate driver	IN_HS	Referenced to SGND	-0.3 ... 6.5	V
PWM input for the low-side gate driver	IN_LS	Referenced to SGND	-0.3 ... 6.5	V
Secondary side positive supply voltages	VCC2H/ VCC2L	Referenced to VEE2H/VEE2L. Not to be used with power supply circuit enabled	-0.3 ... 40	V
Secondary side negative supply voltages	VEE2H/ VEE2L	Referenced to GND2H/GND2L. Not to be used with power supply circuit enabled	-40 ... 0.3	V

2 System and functional description

2.1 Commissioning

The EVAL-FFXMR12KM1DR is powered up at the phoenix-MCV, a two-pin connector that goes together with the control and configuration board EVAL-1ED38X0DCT as shown in Figure 4. The EVAL-1ED38X0DCT comes along with a ribbon cable that can be used for connecting it to the 62mm driver board. Further details about the connectors are shown in Chapter 3.4.

Figure 4 shows the functional blocks of the 62mm evaluation board. Proper gate resistors need to be soldered onto the board, based on the customer switching conditions. A detailed explanation for selecting suitable resistors is explained in the next chapter. The module is soldered onto the gate terminals of the 62 mm module. A suited probe tip adaptor can be soldered next to the gate terminals to measure the gate source voltage (V_{GS}).

A suitable connection of the active-clamp solder pins (6) has to be established to use this function and make the device safe in case of an overvoltage event at turn-off. The DESAT pin of the gate drivers is also connected via the individual drain contact.

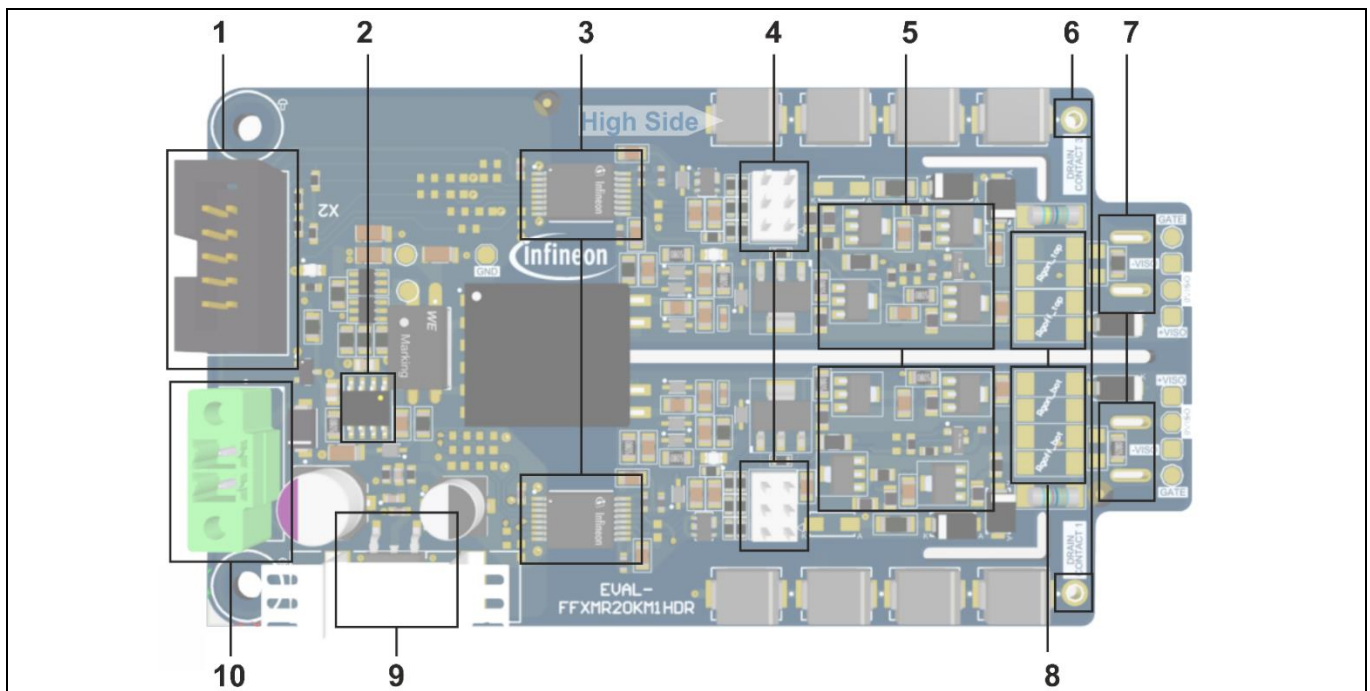

Figure 4 Overview of the functional blocks of the EVAL-FFXMR20KM1HDR

1. Connector for input signals (find the pin assignment in Table 4)
2. Infineon self-oscillating half-bridge driver IC IR2085S
3. Infineon 1ED3890MU12M single-channel 5.7 kV (rms) isolated gate driver IC with I2C configurability
4. Negative gate-source voltage adjustment
5. Booster stage
6. Drain contact to be connected to the power terminals of the individual drain of the MOSFET.
7. Gate resistor solder pads
8. Connector for gate and source terminals
9. Infineon NPN type voltage regulator TLE4284DV
10. Power supply for +24 V (find the pin assignment in Table 3)

System and functional description

2.2 Description of the functional blocks

The most important functional blocks are shown in Figure 4 and will be explained further in the following chapter.

The on-board isolated DC/DC converter generates an output voltage of up to 18 V depending on the load conditions. The positive voltage is fed to the secondary side of the driver circuit directly, whereas the negative voltage is adjustable from -5.9 V to -0.4 V by using the jumper settings shown in Figure 6.









								
Rfb	3.5 kOhm	3 kOhm	2.5 kOhm	2 kOhm	1.5 kOhm	1 kOhm	0.5 kOhm	0 Ohm
Vneg	-5.9 V	-5.1 V	-4.3 V	-3.5 V	-2.8 V	-2 V	-1.2 V	-0.37 V

Figure 5 Jumper settings for the negative voltage adjustment V_{neg}

The adjustable output voltage (V_{neg}) can be calculated by the equation given in Figure 6.

$$V_{neg} = -1.25V * \left(1 + \frac{R2'}{R1'} \right) - 65e^{-6}A * R2 + 5V, \text{ where } R2' = 2.2k\Omega + 390\Omega + Rfb$$

Figure 6 Equation to calculate V_{neg} for the negative gate voltage adjustments

The EVAL-FFXMR20KM1HDR is equipped with the EiceDRIVER™ Enhanced single-channel isolated gate driver 1ED3890MC12M. The 1ED3890MC12M belongs to the EiceDRIVER™ Enhanced 1ED38xx family (X3 digital family) and has a I²C bus for parameter adjustment.

The output of the driver is connected to a push-pull booster stage to increase the output power of the driver stage. Further details about the design of booster stages can be found in *External Booster for Driver IC* [1].

The gate resistors are not included and need to be soldered on the board according to customer needs. Metal electrode leadless faces (MELF) packages are recommended, since they are very robust in terms of impulse currents, and offer a long-term reliability under thermal stress. Two resistors can be attached in parallel for both the external gate turn-on resistance ($R_{G,on}$) and the external gate turn-off resistance ($R_{G,off}$) signal path.

System and functional description

2.2.1 Prerequisites

- PC with Windows 7 or higher with Infineon XMC USB driver installed
- [EiceDRIVER™ 1ED38x0 DCT software](#) installed
- USB A to micro-USB cable
- [EiceDRIVER™ Eval-1ED38x0DCT](#) microcontroller board
- Board EVAL-FFXMR20KM1HDR
- 62mm module attached to the gate pins of the driver board
- Low-voltage power supply for supplying primary-side power supply circuit, capable of supplying 24 V
- High-voltage power supply for supplying the power stage
- A suitable inductive load for double-pulse testing

2.2.2 2.1.2 EiceDRIVER™ 1ED38x0 DCT software installation process

The following steps are required in order to install the EiceDRIVER™ 1ED38x0 DCT software. The same process should be used for downloading future software updates.

If the Infineon toolbox is already installed, please jump to step 3.

1. Visit www.infineon.com/toolbox and download the latest version
2. Start the toolbox
3. Search for “EiceDRIVER 1ED38x0 DCT”
4. Install the software
5. Locate the installation directory and find the USB device drivers
6. Install the XMC USB drivers

2.2.3 Evaluation of the EVAL-FFXMR20KM1HDR with another microcontroller

While not recommended to new users or for fast evaluation, the EVAL-FFXMR20KM1HDR can be used with any microcontroller capable of communicating over I²C and generating PWM signals. For this, it is important to read the documentation, especially the reference manual, of the gate drivers. Special care should be taken when reviewing the I²C section, where the byte format, read/write operation and initial addressing are described. The EiceDRIVER™ 1ED38x0 DCT can be used to configure the registers and export them.

2.2.4 Power-up sequence

Attention: Be very careful when connecting and disconnecting the Eval-1ED38x0DCT board and the EVAL-FFXMR20KM1HDR. This should be done without power being supplied to any of the boards.

1. Connect the EiceDRIVER™ 1ED38x0 DCT (connector X150) to the connector X1 of the EVAL-FFXMR20KM1HDR via the ribbon cable.
2. Connect the EiceDRIVER™ 1ED38x0 DCT via the USB cable to the computer used for configuration.
3. Make sure that your test setup, e.g. DC-Link, or inductive load is connected properly.
4. Supply the input side power supply according to Table 3.
5. The green LEDs will turn on to signal that the voltages are present.
6. Start the GUI-software for the EiceDRIVER™ 1ED38x0 DCT.exe.
7. Press the “Quick-Start” button (Comes up if everething works correct – see Figure 7)
8. If the GUI is connected correctly with the [EiceDRIVER™ Eval-1ED38x0DCT](#) microcontroller board and the EVAL-FFXMR20KM1HDR, the landing page will change as shown in Figure 8.
9. Use the GUI to configure the gate drivers corresponding to your requirements, example see Figure 9.

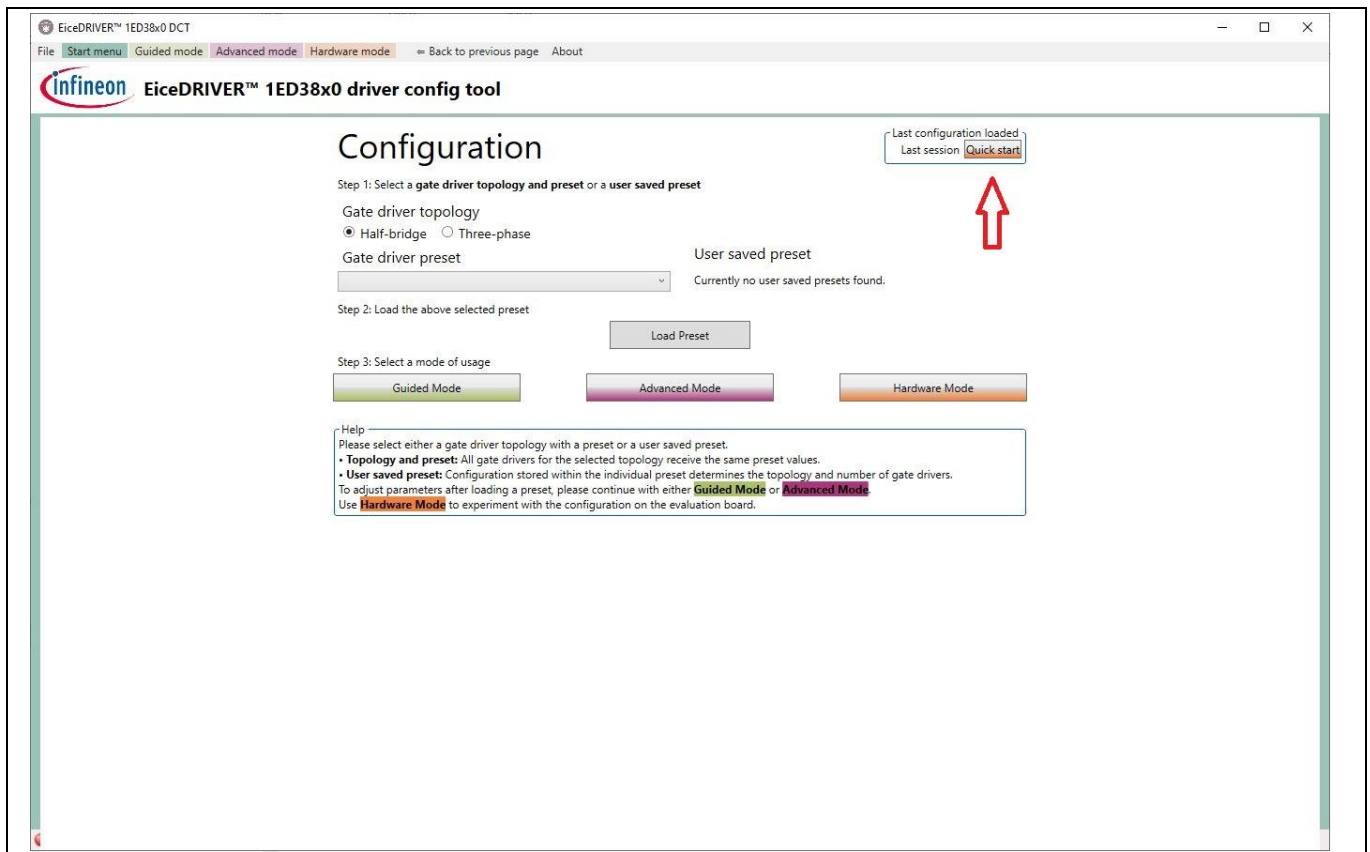

Figure 7 Landing page after starting the GUI 1ED38x0_DCT.exe

Figure 8 shows the landing page that is available once the communication between the computer, the [EiceDRIVER™ Eval-1ED38x0DCT](#) and the EVAL-FFXMR20KM1HDR is working. Please click on the quick start button for that.

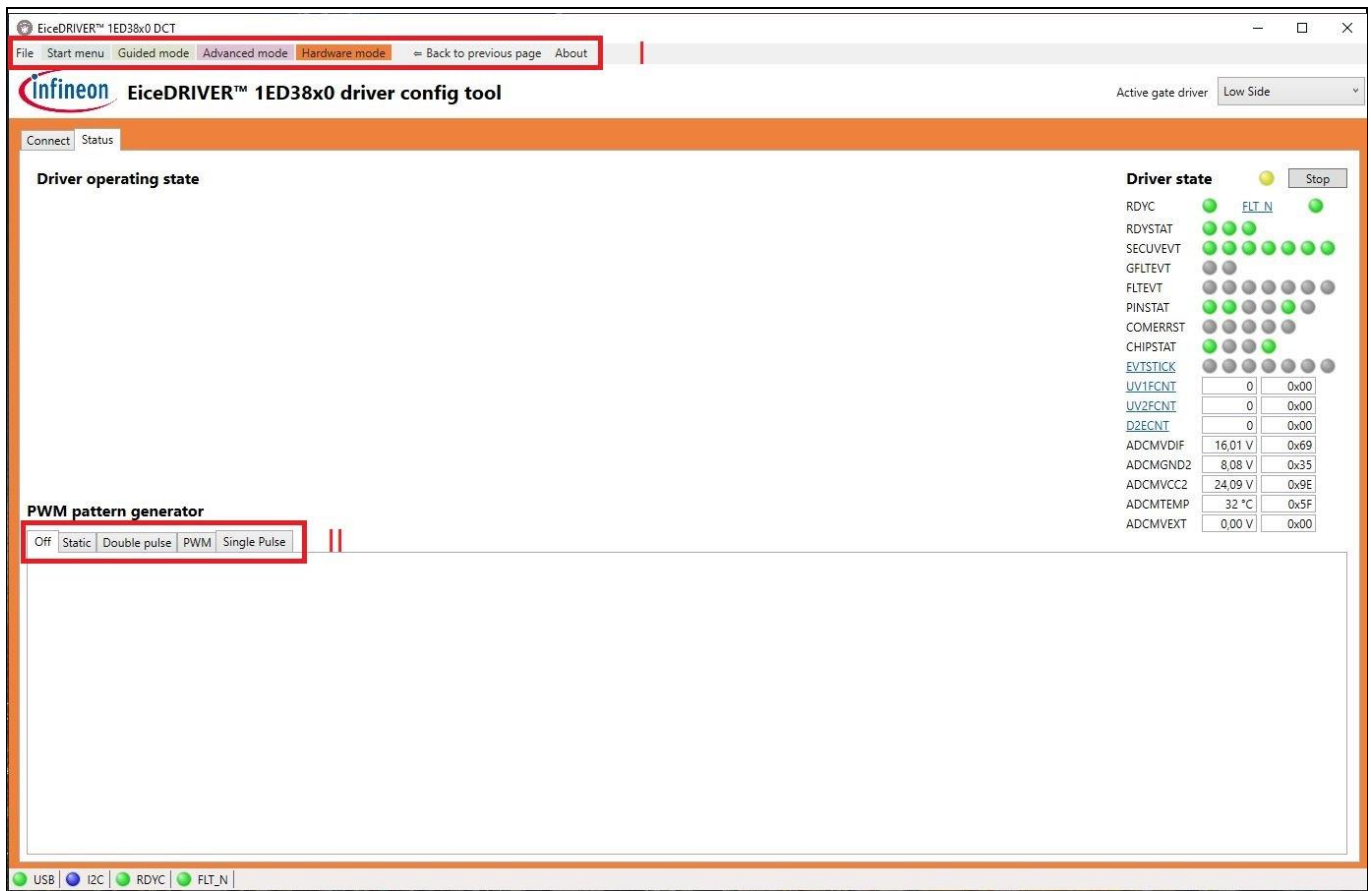

Figure 8 Landing page if GUI is connected with the DCT-board and the EVAL-FFXMR20KM1HDR

The landing page as shown in Figure 8 can be separated into two sections. The top bar that is used to set up the registers of the gate driver via the I²C bus.

The bottom section of the page offers the user various control functions. Either the static switching, double pulse or the PWM signals can be used, whereby the frequencies and the duty cycle can be freely selected within certain limits.

The display on the right shows status signals and registers contents. If you move the PC mouse over the names of the corresponding registers, the contents are briefly explained.

2.3 Introduction to EiceDRIVER™ 1ED38x0 DCT

This chapter will provide a short overview of the EiceDRIVER™ 1ED38x0 DCT, for a detailed explanation of the software please read the EiceDRIVER™ 1ED38x0 DCT user guide.

The EiceDRIVER™ 1ED38x0 DCT driver IC is highly configurable via I²C. In order to familiarize yourself with it, and to easily evaluate its performance, the EiceDRIVER™ 1ED38x0 DCT microcontroller board can be used with the EVAL-FFXMR20KM1HDR. It is recommended that first-time users select the guided mode, as this also provides a detailed explanation of each configurable parameter as shown in Figure 9.

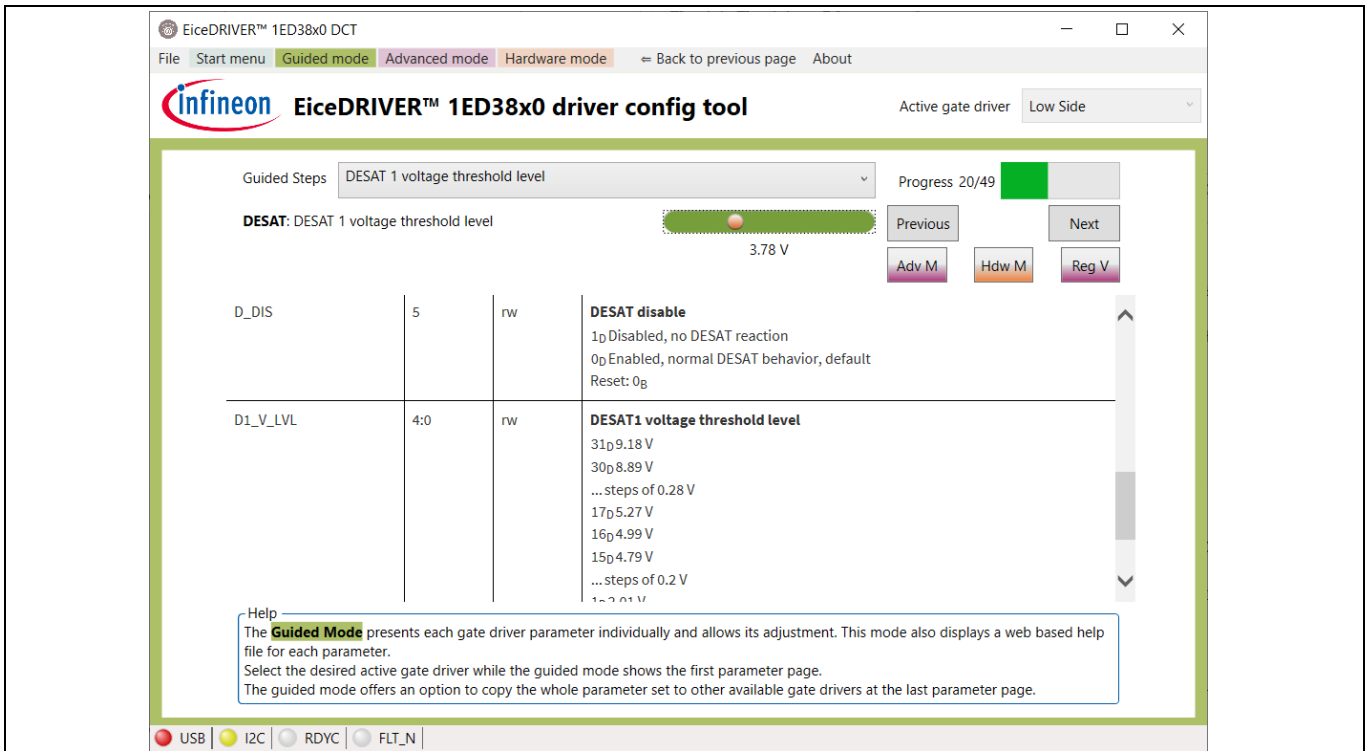

Figure 9 Example: DESAT 1 voltage threshold level of the guided mode

Figure 9 shows the guided mode with more details on how to configure the threshold level of the DESAT 1 function for example. Beside that, the advanced mode can be used as shown in Figure 10.

Please read the reference manual of the EiceDRIVER™ 1ED38x0Mc12M to get detailed information on the various functions of the X3 digital gate driver.

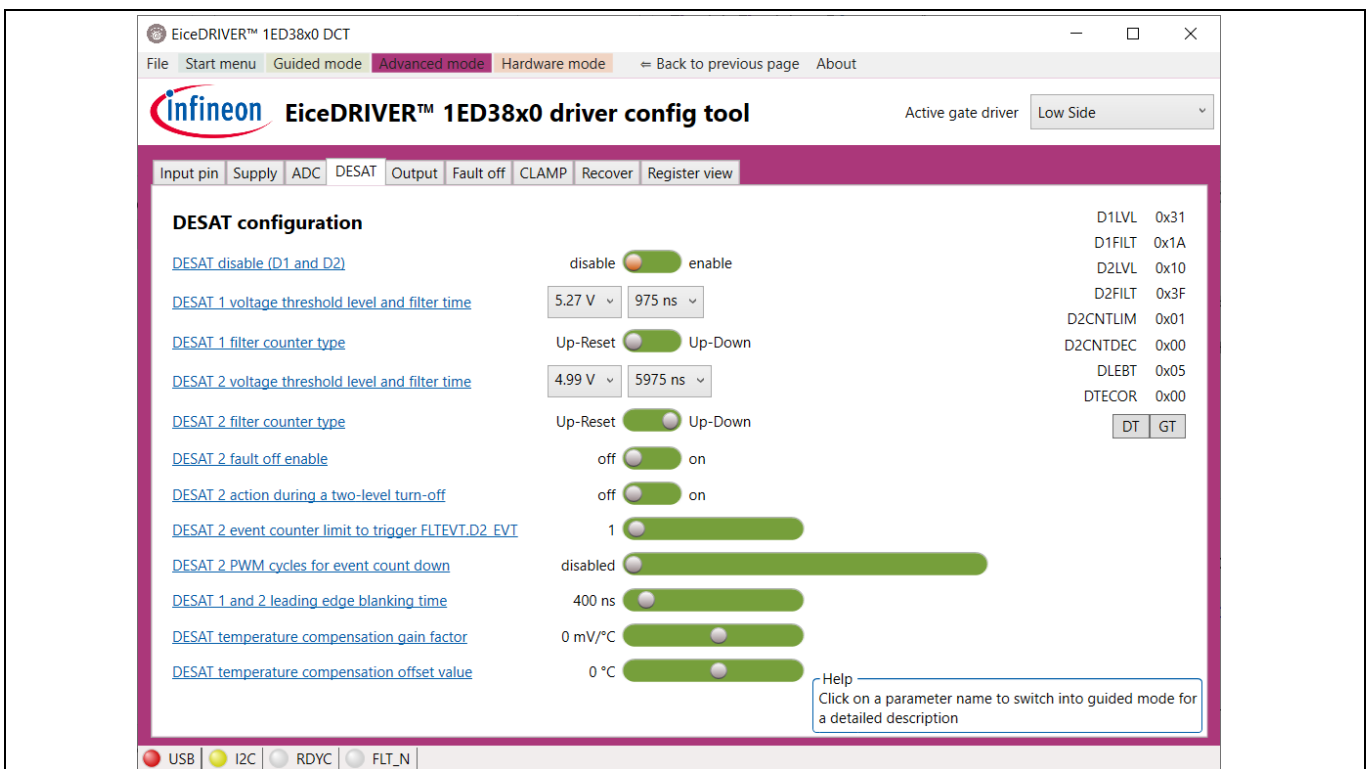

Figure 10 Example: DESAT configuration table of the advanced mode

System design

3 System design

The EVAL-FFXMR20KM1HDR is a simple driver board for evaluating the switching performance of our 62 mm module including our new 2kV CoolSiC™ Trench MOSFET technology. All functional blocks are designed to show a simple circuit approach to accommodate the best performance of our new SiC devices.

3.1 Schematics

The schematics that are shown here are just an excerpt from the entire documentation that can be found in the PCB design data of the EVAL-FFXMR20KM1HDR board homepage at www.infineon.com.

The linear voltage regulator TLE4284DV in a DPAK package is used to deliver an accurate supply voltage (VDRV), which is used as supply voltage of the push-pull stage at the isolated DC-DC converter. The widely-known IR2085s is used as half-bridge driver as shown in Figure 11. This approach can also be used to generate a galvanic isolation of two independent driver stages, e.g. of a full bridge or a 3-phase topology as shown in the CoolSiC™ MOSFET motor drives evaluation board for 7.5 kW [2].

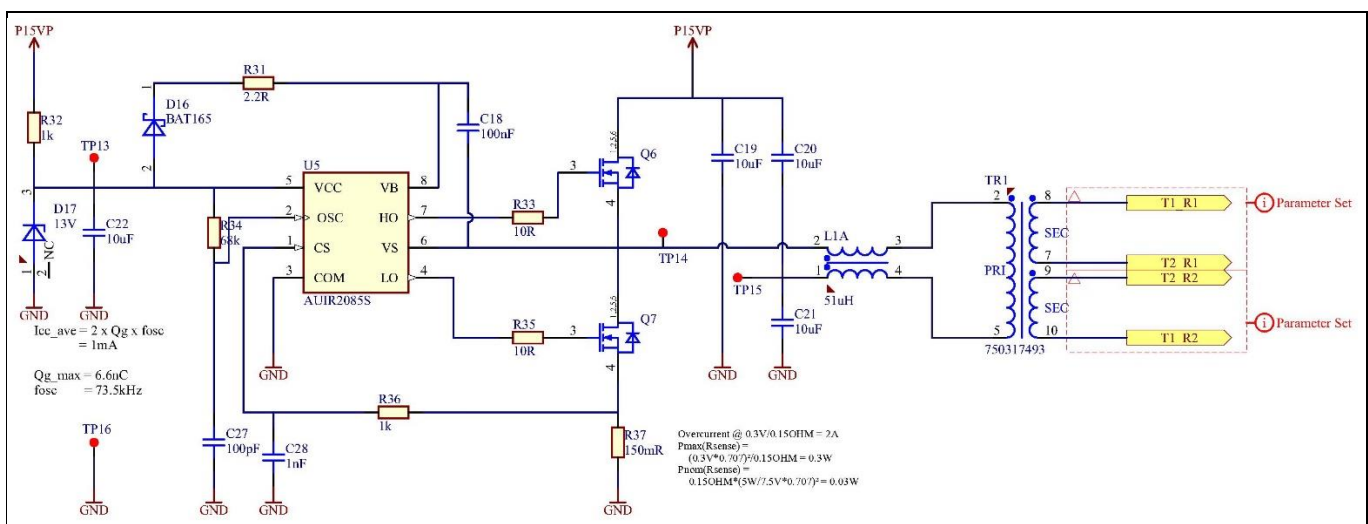

Figure 11 Schematics of the power supply of the driver stage

3.2 Layout

The layer stack of the board consists of four layers, including the top, bottom and two internal layers. The top layer is used for the direct connection of signals of most of the components as shown in Figure 12. The bottom layer is used to feed in the negative output signals –VISO on the secondary side that is the driver output side of the board. The internal layers 1 and 2 are used to improve the driver output signals against noise as shown in Figure 14 and Figure 15. The internal layer 1 is used for the ground signal of the secondary side and to route the signals of the driver output to the booster stage. The Gerber and ODB++ files can also be accessed via the PCB design data tab of the EVAL-FFXMR20KM1HDR board homepage at www.infineon.com.

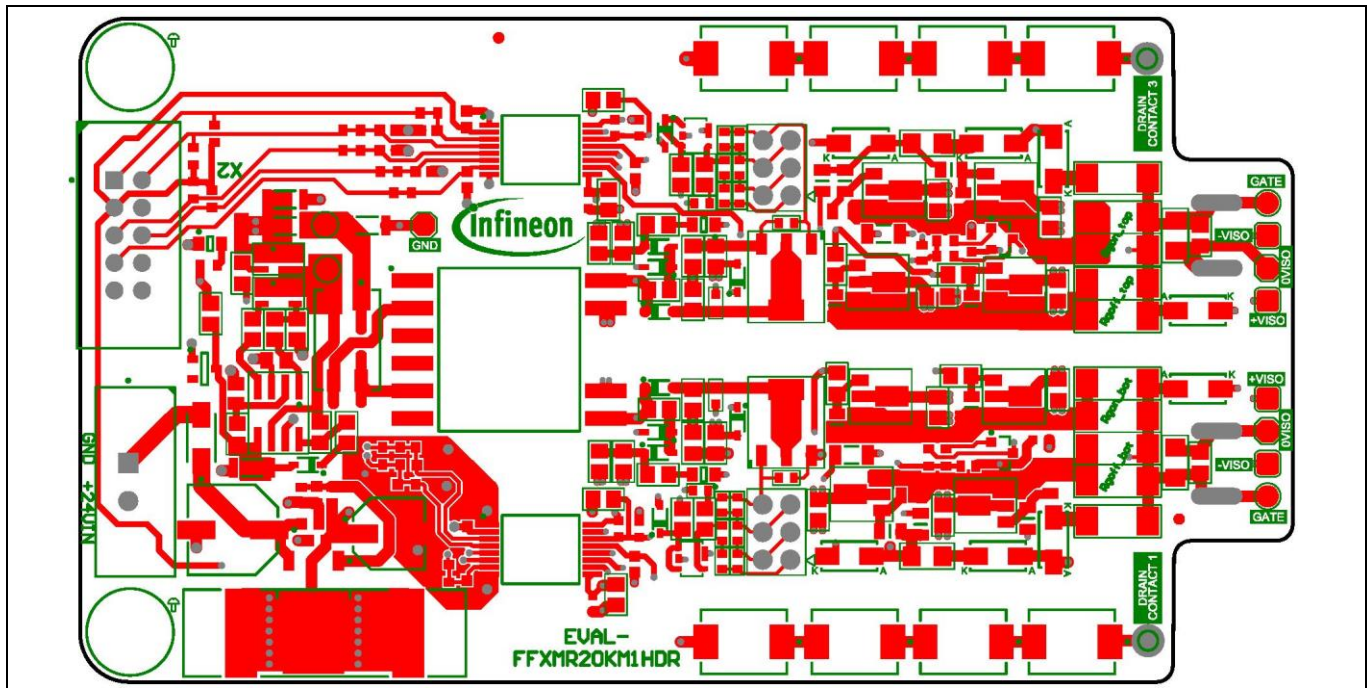

Figure 12 FFXMR12KM1DR with the top layer highlighted

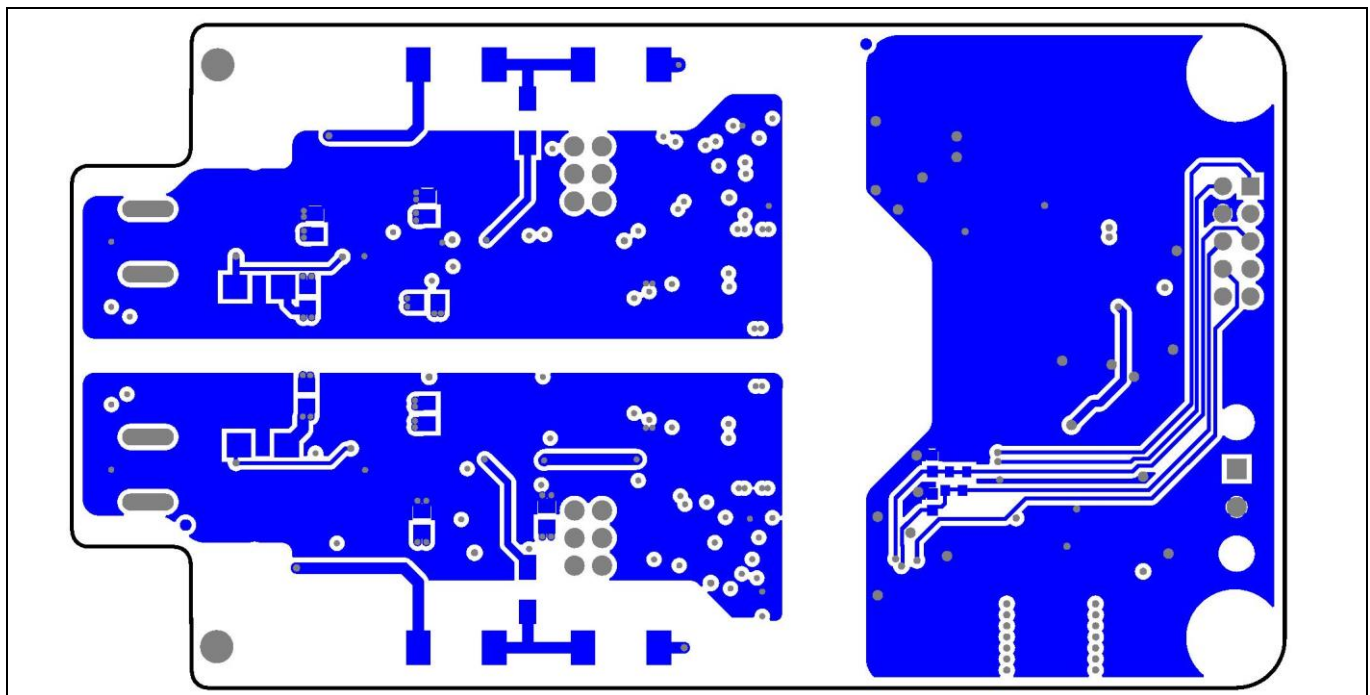

Figure 13 FFXMR12KM1DR with the bottom layer highlighted

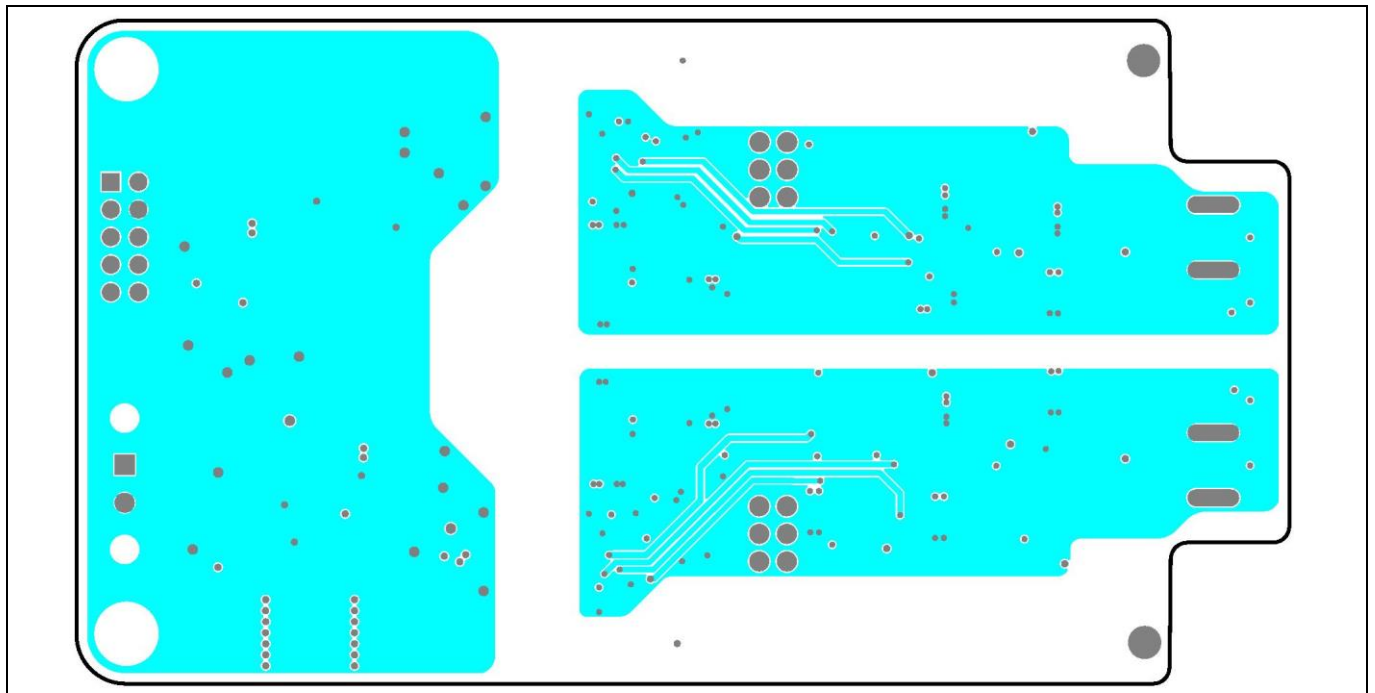

Figure 14 FFXMR12KM1DR with the internal layer 1 highlighted

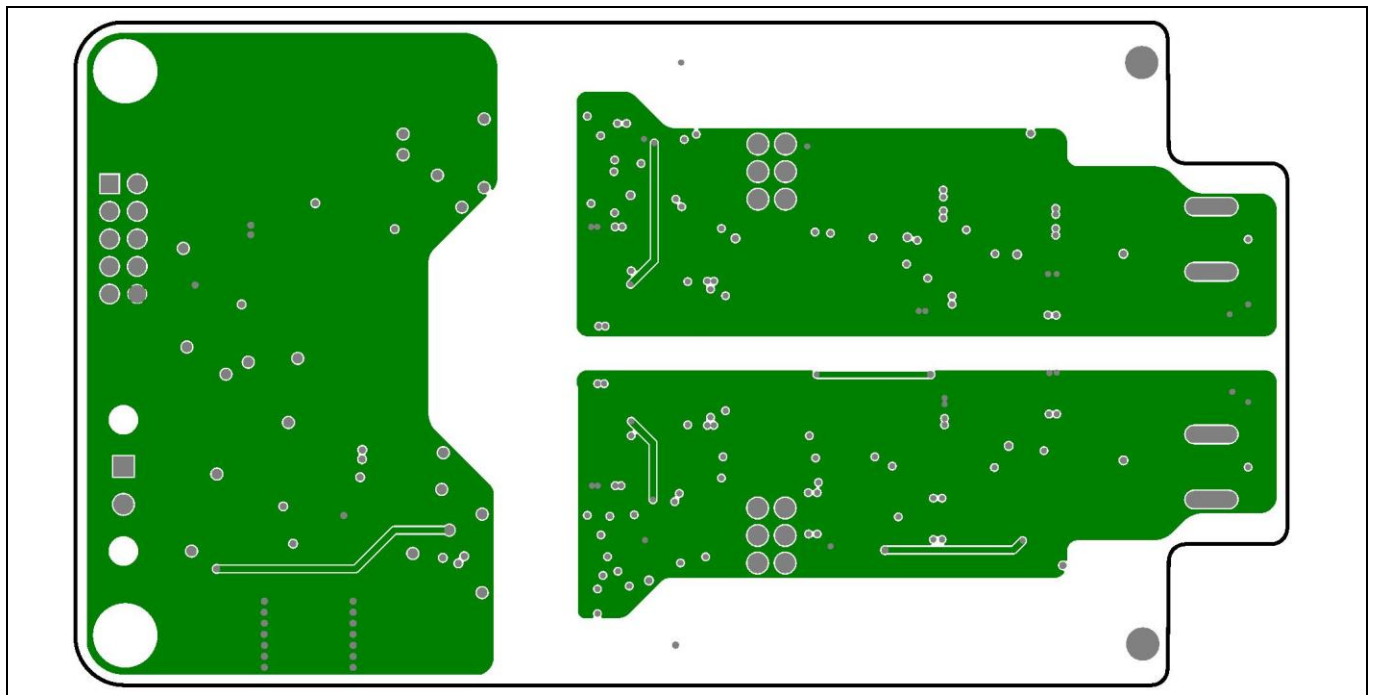

Figure 15 FFXMR12KM1DR with the internal layer 2 highlighted

System design

3.3 Bill of material

Please note that the detailed BOM of the EVAL-FFXMR20KM1HDR is available at www.infineon.com.

3.4 Connector details

Table 3 Connector X1

PIN	Label	Function
X1.1	+24VIN	24 V input
X1.2	GND	Input ground

Table 4 Connector X2

PIN	Label	Function
X2.1	SCL	I ² C clock line
X2.2	SDA	I ² C data line
X2.3	P3VP	Supply voltage for gate driver ICs primary side supply (shorted to VCC1)
X2.4	SGND	Ground for primary side
X2.5	RDYC	Connection to both RDYC pins of the gate driver ICs
X2.6	FLT#	Connection to both FLT# pins of the gate driver ICs
X2.7	res.	Not used
X2.8	P15VP	Supply voltage for the isolated power supply
X2.9	VCC1	Supply voltage for gate driver ICs primary side supply (shorted to P3VP)
X2.10	SGND	Ground for primary side

System performance

4 System performance

4.1 Test setup

Figure 16 captures the test setup and voltage measurement techniques for double-pulse testing. The first turn-on pulse of the low-side device (S2) establishes the desired current value (e.g. nominal data sheet current in this case) in the inductive load, and the turn-off pulse makes the current flow in the freewheeling diode (e.g. body diode of the top device S1 in this case). An external inductance value was used in the actual test setup.

The second turn-on pulse measures the low-side device turn-on characteristics, which also include the reverse recovery of the freewheeling body diode.

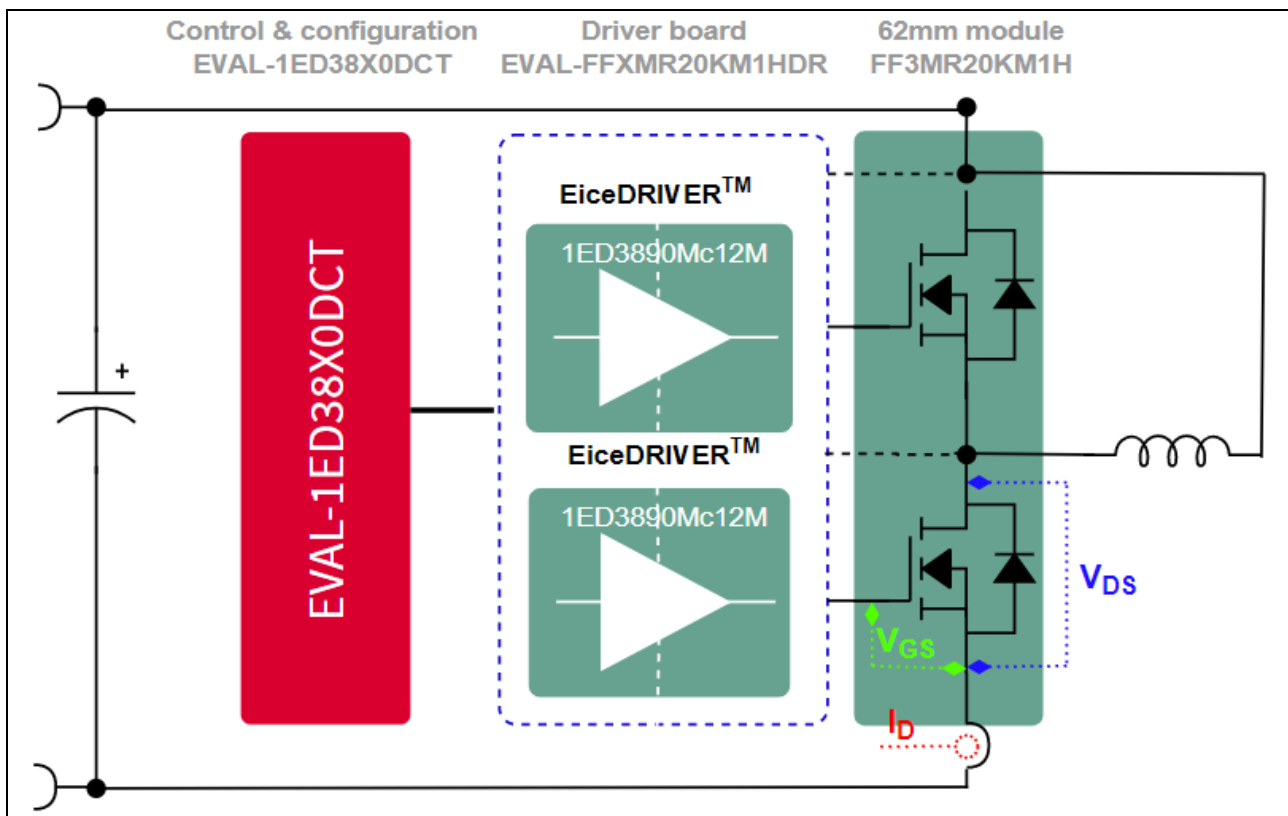

Figure 16 Test setup and voltage measurement techniques

System performance

4.2 Switching performance

This chapter presents some examples of extracted waveforms of the module FF6MR20KM1H, which has been characterized with the help of the evaluation board.

One key aspect in designing half-bridge topologies with SiC MOSFET devices is to investigate the parasitic turn-on of the upper switch during switching of the lower switch, and vice versa. This effect may be caused by a high dv/dt of a SiC MOSFET, which can exceed $50 \text{ kV}/\mu\text{s}$ for a CoolSiC™ MOSFET.

To mitigate the situation, two approaches have been considered here.

As a first approach, different gate source voltages ($V_{GS} = -5 \dots 0 \text{ V} / +15 \dots 18 \text{ V}$) are used to drive the gate of the device. In the case of unipolar switching, the dv/dt can be reduced by using larger gate resistance to mitigate the parasitic turn-on events. This is a significant advantage demonstrating the simple gate controllability of CoolSiC™ MOSFET devices.

4.2.1 MOSFET switch-on behavior

The negative output voltage of the board was adjusted from -3 V to 0 V as shown in the upper graph of Figure 17.

The overall switching behavior is independent of the negative gate-source voltage (V_{GS}).

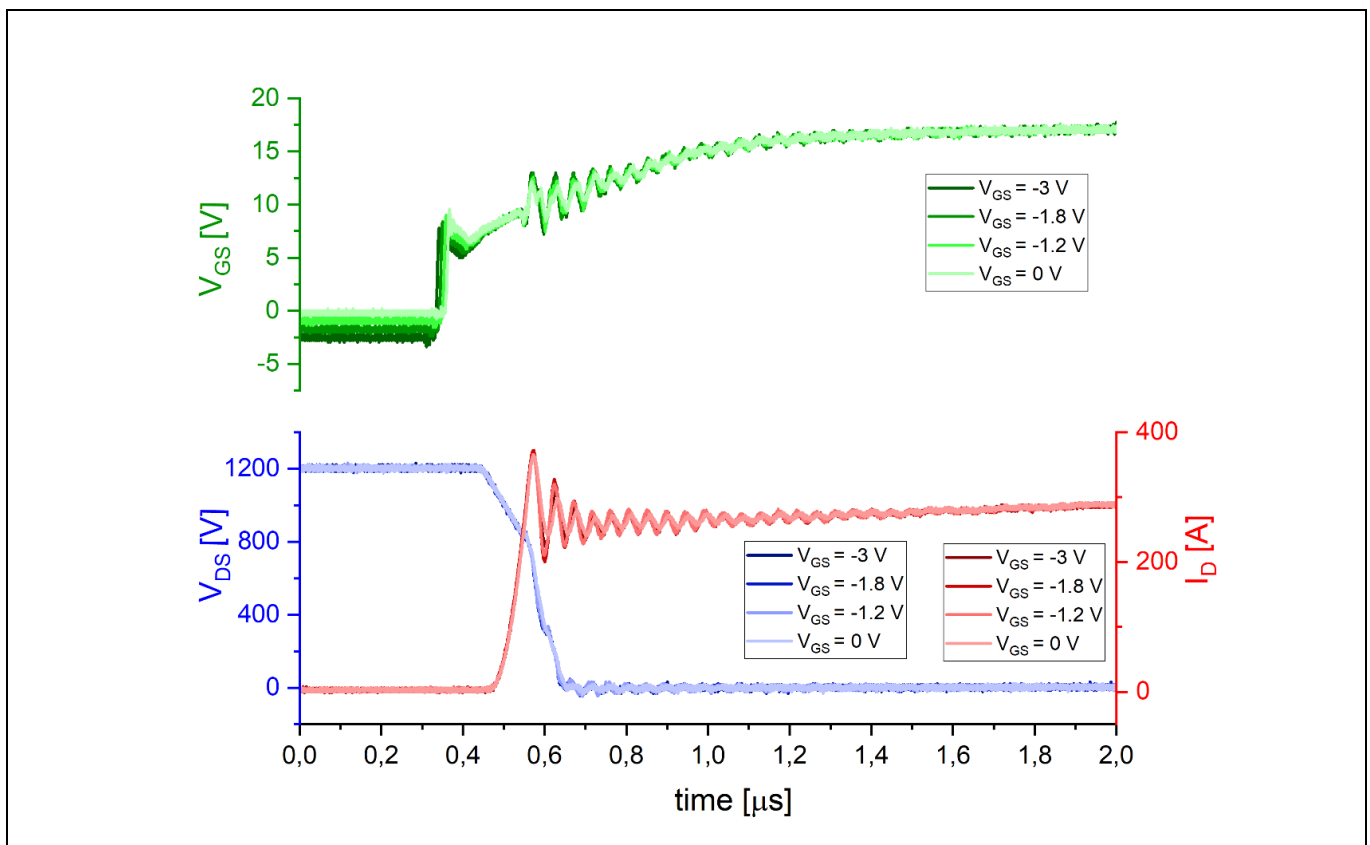

Figure 17 Turn-on waveforms with different gate source voltages ($V_{GS} = -3 \dots 0 \text{ V} / +18 \text{ V}$)

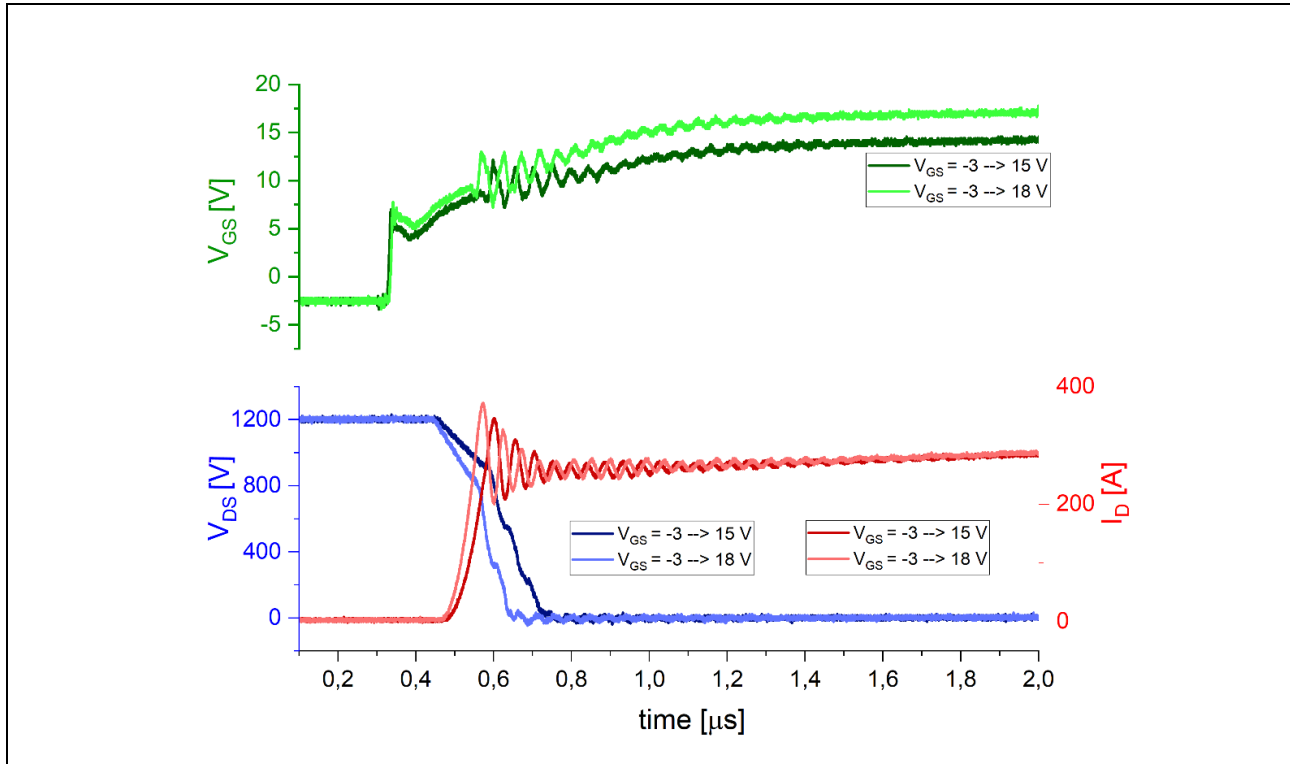

Figure 18 Turn on waveforms of typical bipolar voltage values with $V_{GS} = -3...+15 V / ...+18 V$.

4.2.2 MOSFET switch-off behavior

The turn-off switching with different bipolar voltage levels was observed by changing the $R_{G,off}$ in a way that the gate current stays the same for each testing sequence. The waveforms during turn-off are shown in Figure 19 showing the same course of the current and voltage curves for the different negative values of V_{GS} .

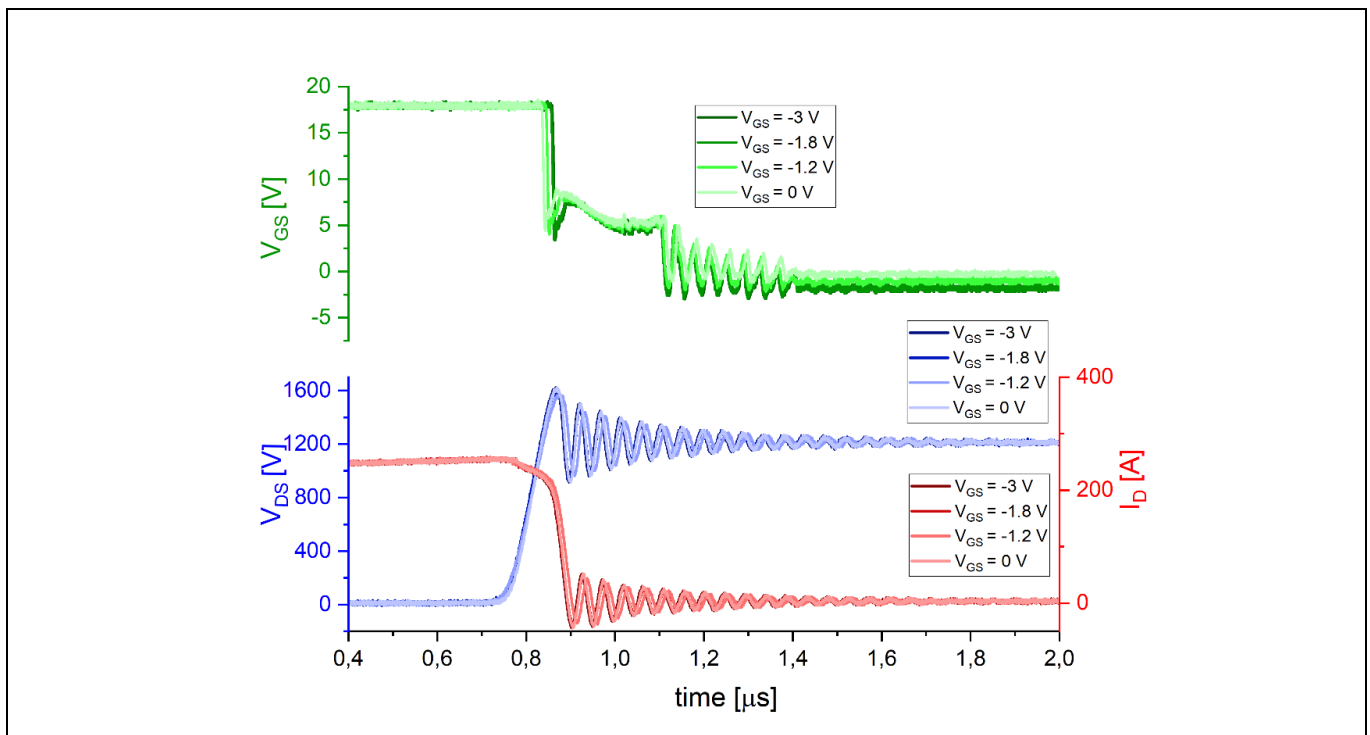

Figure 19 Turn-off waveforms with different ($V_{GS} = -3... 0 V / +18 V$)

5 References and appendices

5.1 References

- [1] Infineon Technologies AG. AN2013-10 (Rev. 2014): *External Booster for Driver IC V 1.6* www.infineon.com
- [2] Infineon Technologies AG. AN2019-25: *CoolSiC™ MOSFET motor drives evaluation board for 7.5 kW - Eval-M5-E1B1245N-SiC* www.infineon.com

5.2 Additional information

This is a preliminary version of the user guide before the final release of the board.



Revision history

Document version	Date of release	Description of changes
0.2	2023-03-27	Preliminary version

Trademarks

All referenced product or service names and trademarks are the property of their respective owners.

Edition 2023-02-27

Published by

Infineon Technologies AG

81726 Munich, Germany

© 2024 Infineon Technologies AG.

All Rights Reserved.

Do you have a question about this document?

Email: erratum@infineon.com

Document reference

UG-2022-14

For further information on the product, technology, delivery terms and conditions and prices please contact your nearest Infineon Technologies office (www.infineon.com).

WARNINGS

Due to technical requirements products may contain dangerous substances. For information on the types in question please contact your nearest Infineon Technologies office.

Except as otherwise explicitly approved by Infineon Technologies in a written document signed by authorized representatives of Infineon Technologies, Infineon Technologies' products may not be used in any applications where a failure of the product or any consequences of the use thereof can reasonably be expected to result in personal injury.