

All rights strictly reserved. Reproduction or use in any form without written authority from the proprietor.
 Tous droits strictement réservés. Reproduction ou utilisation sans autorisation écrite du propriétaire.
 Propriété de F.C.I. NV.
 © F.C.I. NV.

PC BOARD VERSIONS		
PRODUCTNR:	PCB THICKNESS	DIM*A"
70227-X01/X01LF	1.6	2.90
70227-X11/X11LF	2.4	3.53

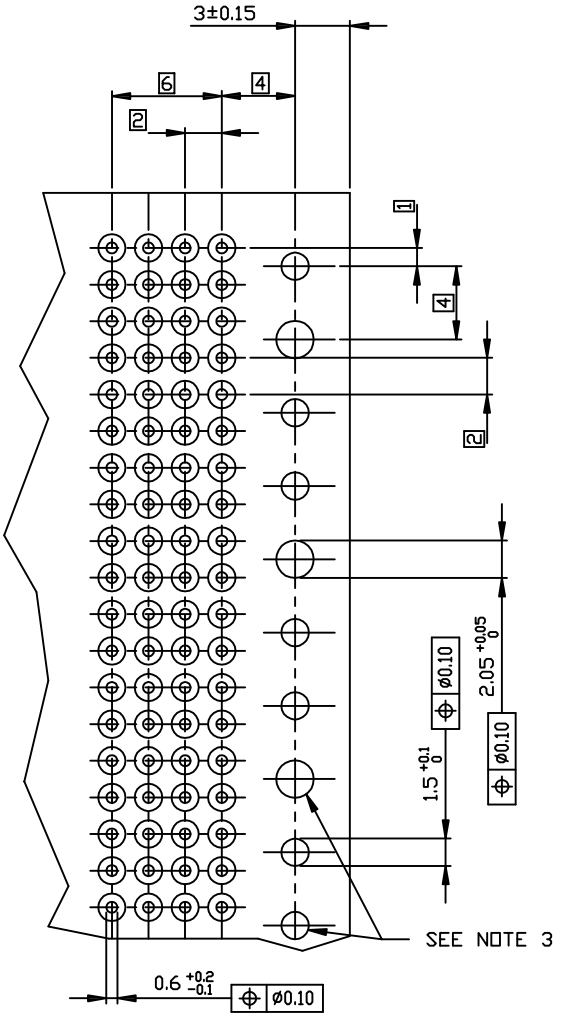
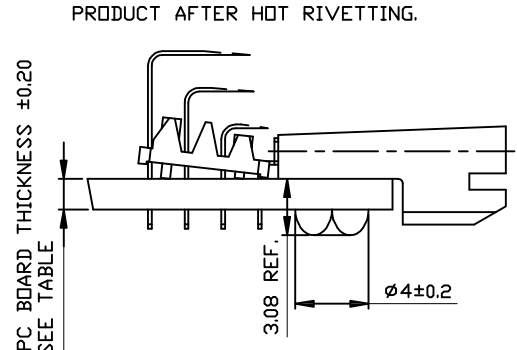
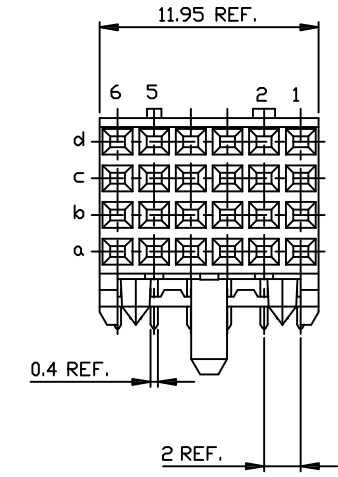
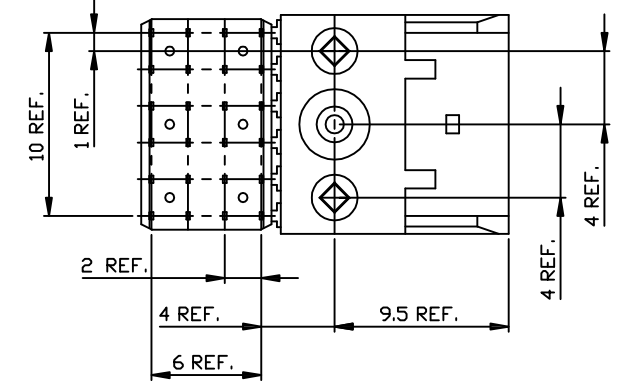
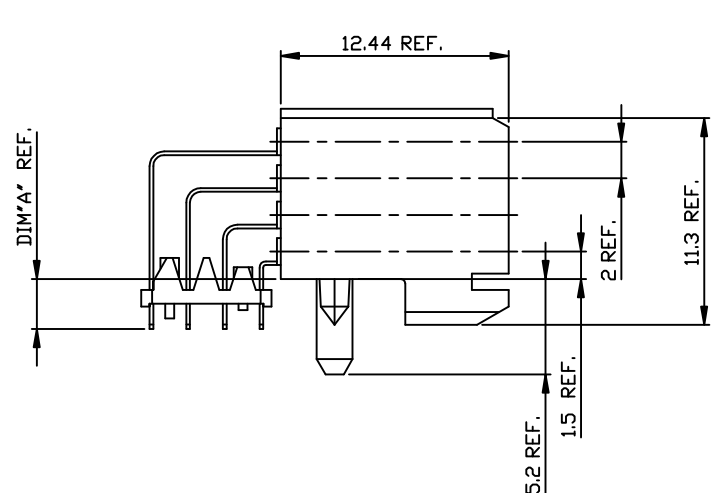

- NOTES:**
- 1 BODY MAT'L: LIQUID CRYSTAL POLYMER 30% GLASS
FLAME RETARDANT ACC. UL 94-V0
 - 2 TERMINAL MATERIAL: PHOSPHOR BRONZE.
 - 3 INDICATED HOLES ARE UNPLATED.
 - 4 For PLATING SPEC, REFER TO DRAWING 10097866.
 - 5 PRODUCT MARKING: PARTNUMBER & BATCH ID.
 - 6 THIS PRODUCT MEETS EUROPEAN UNION DIRECTIVES AND OTHER COUNTRY REGULATIONS AS DESCRIBED IN GS-22-008 .
 - 7 THE HOUSING WILL WITHSTAND EXPOSURE TO 260DEGREE PEAK TEMPERATURE FOR 10 SECONDS IN A WAVE SOLDER APPLICATION.

PLATING CONTACT AREA:

DASH NR:	PERFORMANCE LEVEL
-1YY/1YYLF	TELCORDIA CO
-2YY/2YYLF	CUSTOMER SPECIAL
-3YY/3YYLF	CUSTOMER SPECIAL

mat'l. code		tolerances unless otherwise specified		CUSTOMER CDPY		FCI	
ltr	ecnr	no	dr	date	linear	projection	title
K	DG04-004	CLU		041221			RA FEMALE SIGNAL
L	DG06-9477	Cmh		11/17/06			STB 12 mm VERSION
M	DG07-0168	Cmh		05/10/07	angles		
N	DG09-0068	Cmh	03/03/09	dir	R.Trippe	900918	product family METRAL(tm)
					engr	H. Bouknecht	940308
H	V00578	LLA	000316	chr	A van Zanten	900918	scale
J	V00847	LLA	000530	appd	H v Woensel	900918	5d
sheet	revision	N	N	N			
Index	sheet	1	2	3			
							product family METRAL(tm)
							code
							213
							sheet
							1 of 3
							70227

PC BOARD VERSIONS		
PRODUCTNR:	PCB THICKNESS	DIM'A"
70227-X02/X02LF	1.6	2.90
70227-X12/X12LF	2.4	3.53

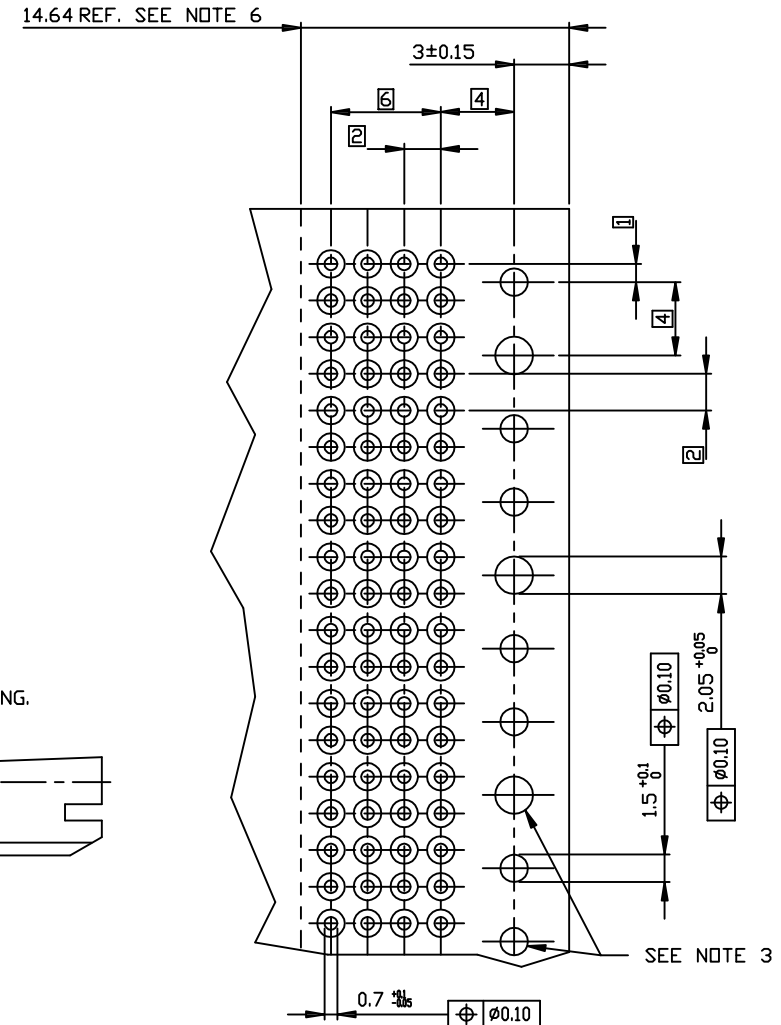
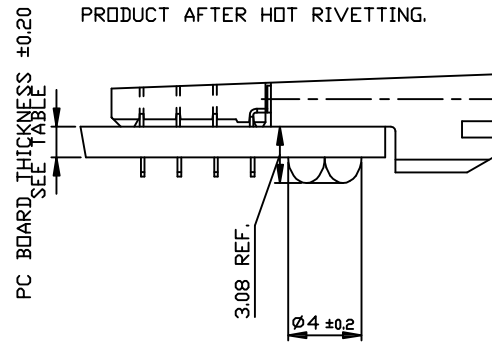
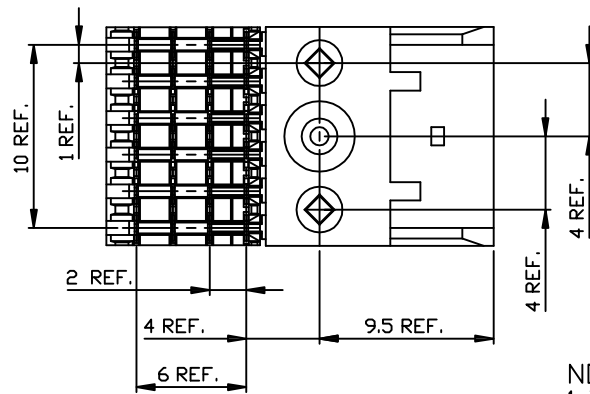
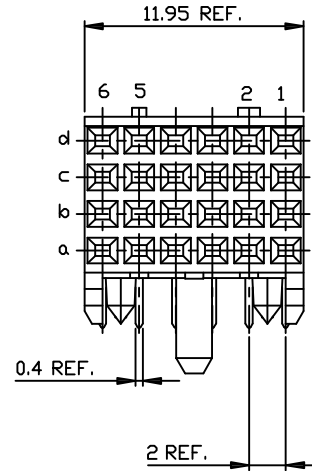
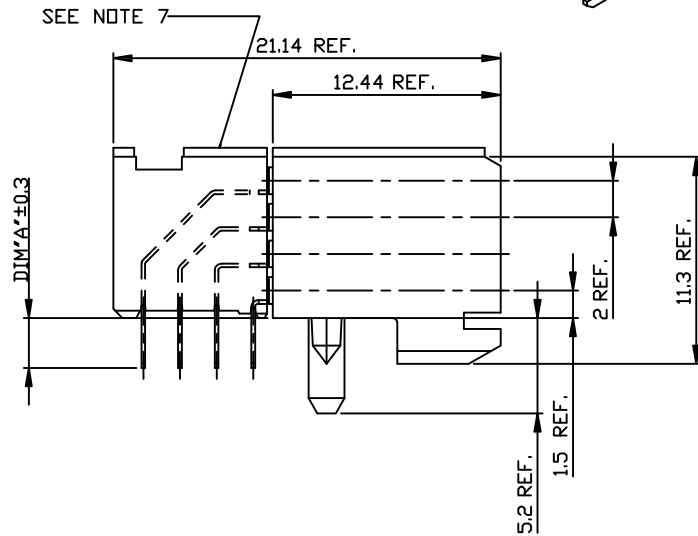
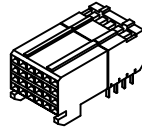

- NOTES:
- BODY MAT'L: LIQUID CRYSTAL POLYMER 30% GLASS FLAME RETARDANT ACC. UL 94-V0
 - TERMINAL MATERIAL: PHOSPHOR BRONZE.
 - INDICATED HOLES ARE UNPLATED.
 - For PLATING SPEC, REFER TO DRAWING 10097866.
 - PRODUCT MARKING: PARTNUMBER & BATCH ID.
 - SET BACK FOR PRESS BLOCK.
 - TOP SURFACE OF PRESS BLOCK MAY EXTEND UP TO 0.4MM HIGHER THAN HOUSING. THIS MAY AFFECT THE TAIL LENGTH BEFORE APPLICATION TO A BOARD
 - THIS PRODUCT MEETS EUROPEAN UNION DIRECTIVES AND OTHER COUNTRY REGULATIONS AS DESCRIBED IN GS-22-008
 - THE HOUSING WILL WITHSTAND EXPOSURE TO 260DEGREE PEAK TEMPERATURE FOR 10 SECONDS IN A WAVE SOLDER APPLICATION.

PLATING CONTACT AREA:

DASH NR:	PERFORMANCE LEVEL
-1YY/1YYLF	TELCORDIA CO
-2YY/2YYLF	CUSTOMER SPECIAL
-3YY/3YYLF	CUSTOMER SPECIAL

mat'l. code		tolerances unless otherwise specified		CUSTOMER CDPY		FCJ	
l	tr	ec	n	no	dr	date	www.fcjconnection.com
				linear			title RA FEMALE SIGNAL
				projection			STB 12 mm VERSION
				angles			product family METRAL(tn)
				dir	Dr de Bil	970529	code 213
				engr	P. Schalk	970529	sheet 2 of 2
				chr	P. Schalk	970529	
				appdr	Coelmans	970529	
sheet	revision			scale	5:1		
Index	sheet						

All rights strictly reserved. Reproduction or use in any form without written authority from the proprietor. Property of FCI NV. © FCI NV.

PC BOARD VERSIONS		
PRODUCTNR:	PCB THICKNESS	DIM"A"
70227-X03/X03LF	1.6	2.90
70227-X13/X13LF	2.4	3.53

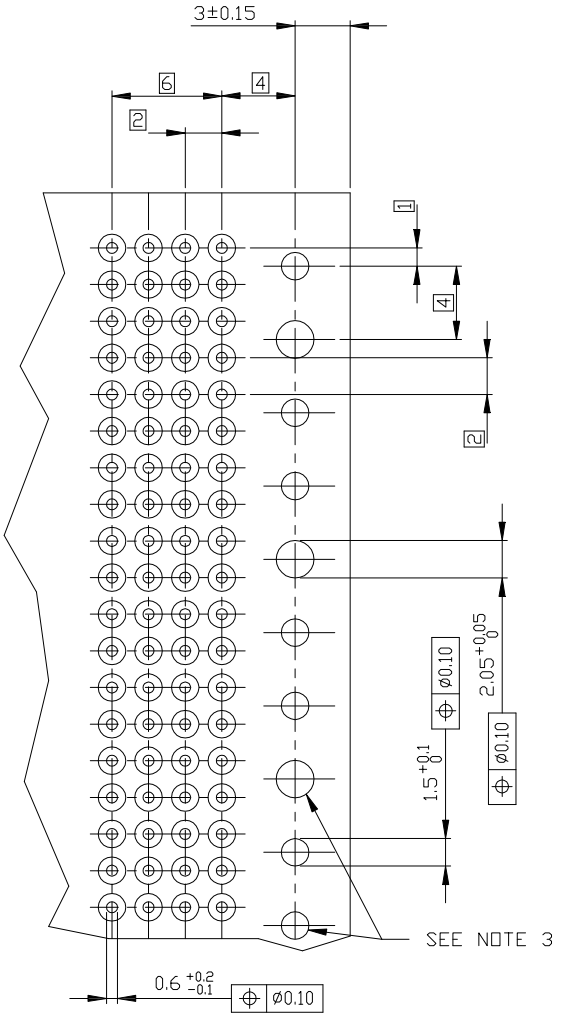
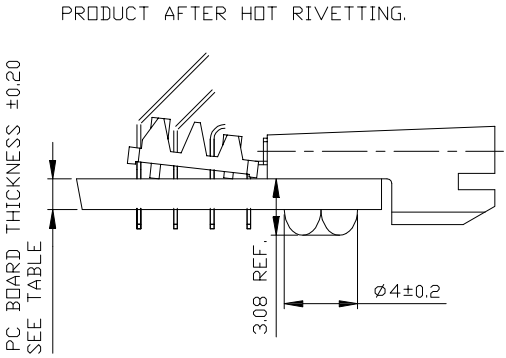
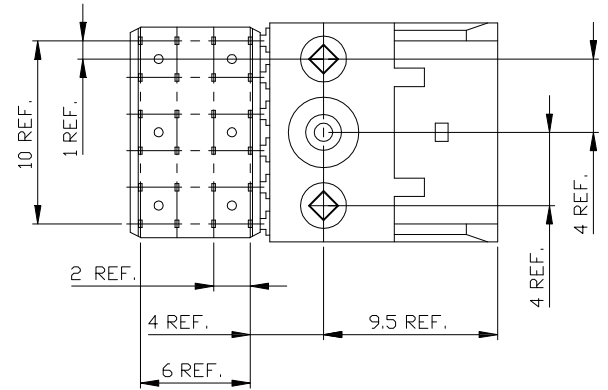
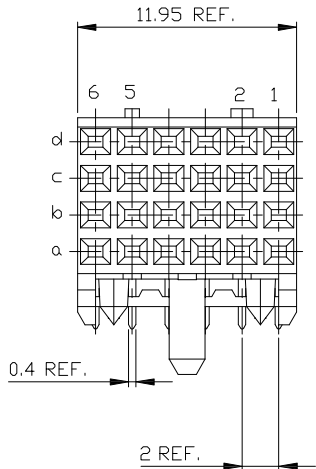
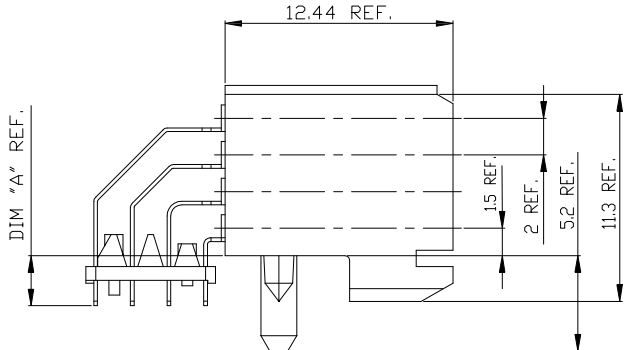

PRODUCT AFTER HOT RIVETTING.

RECOMMENDED HOLE PATTERN, COMPONENT SIDE.

- NOTES:
- 1 BODY MAT'L: LIQUID CRYSTAL POLYMER 30% GLASS FLAME RETARDANT ACC. UL 94-V0
 - 2 TERMINAL MATERIAL: PHOSPHOR BRONZE.
 - 3 INDICATED HOLES ARE UNPLATED.
 - 4 For PLATING SPEC, REFER TO DRAWING 10097866.
 - 5 PRODUCT MARKING: PARTNUMBER & BATCH ID.
 - 6 THIS PRODUCT MEETS EUROPEAN UNION DIRECTIVES AND OTHER COUNTRY REGULATIONS AS DESCRIBED IN GS-22-008 .
 - 7 THE HOUSING WILL WITHSTAND EXPOSURE TO 260DEGREE PEAK TEMPERATURE FOR 10 SECONDS IN A WAVE SOLDER APPLICATION.

PLATING CONTACT AREA:

DASH NR:	PERFORMANCE LEVEL
-1YY/1YYLF	TELCORDIA CO
-2YY/2YYLF	CUSTOMER SPECIAL
-3YY/3YYLF	CUSTOMER SPECIAL

mat'l. code		tolerances unless otherwise specified		CUSTOMER CDPY		FCJ	
ltr	ecn	nodr	date	linear	projection	title RA FEMALE SIGNAL STB 12 mm VERSION	
N				angles	mm	product family	METRAL(tm)
				dir	Heaven Cen	11/17/06	code
				enr	Collins Lu	11/17/06	213
				chr	Beer Fu	11/17/06	sheet
				appd	Joseph Hsla	11/17/06	3 of
sheet	revision			scale	5:1	size	A2
index	sheet					dwg no	70227

All rights strictly reserved. Reproduction or use in any form without written authority from the proprietor. Property of F.C.I. Inc. © F.C.I. Inc.

