



# GainSpan GS1011M Low Power Wi-Fi® Module Family



## PRODUCT OVERVIEW

The GS1011M family of fully certified modules offers a quick, easy and cost effective way for device and appliances manufacturers to add Wi-Fi capabilities to their products. The module provides multiple serial UART or SPI interfaces, enabling connection to any embedded design utilizing a 8/16/32-bit microcontroller via simple commands. The GS1011M is an ideal solution for organizations with limited or no Wi-Fi or RF expertise, as it not only dramatically reduces RF design time but also removes the burden of testing and certification, allowing customers to focus on their core application, product or expertise. The module supports data rates up to 11 Mbps, is compliant with 802.11b and meets regulatory and Wi-Fi Alliance requirements.

Multiple software configurations are available for the stack running on the module. For applications utilizing a small 8 bit microcontroller host, the module supports a serial to Wi-Fi function and runs the full Wi-Fi and TCP/IP networking stacks, completely offloading the host. For applications utilizing more powerful microcontrollers, the networking stack and services can reside on the host while the module provides the IP to Wi-Fi functionality. In addition, it supports WEP/WPA/WPA2 security, Adhoc as well as Wi-Fi Protected Setup (WPS) for ease of provisioning.

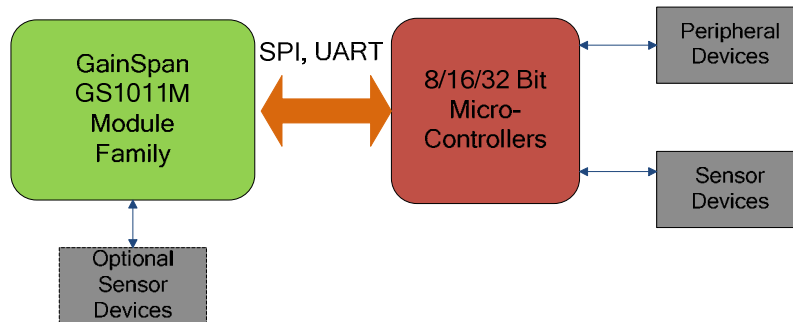

**GS1011M based Embedded Design**

The module family consists of four different SKU's for antenna configuration and output power. The module SKU's are single sided, pin compatible with castellation on the edges for I/O connection so module can be soldered down on customer application base-board.

SKUs	Power Amplifier	Antenna Option
GS1011MIP	Internal PA	PCB Trace Antenna
GS1011MIE	Internal PA	External Antenna (u.FL)
GS1011MEP	External PA	PCB Trace Antenna
GS1011MEE	External PA	External Antenna (u.FL)

## BENEFITS:

- Brings Wi-Fi and web connectivity to any device with a microcontroller and serial HOST interface (UART or SPI)
- Reduces development time, testing and certification burden, accelerating time to market
- Fully contained solution minimizes host processor loading when needed
- Easy device provisioning through Limited AP (embedded web pages) or Wi-Fi Protected Set-up (WPS)
- Ultra low power consumption through dynamic power management
  - Sleep, Deep Sleep, Standby

## FEATURES:

- Operates with standard 802.11 b/g/n access points at speed up to 11 Mbps (802.11b)
  - Infrastructure, Limited AP or Adhoc
- Two serial UART ports
  - Data rates of up to 921.6kbps
- Two SPI ports
  - Supports SPI Master/Slave modes
  - Data rate of up to 3Mbps
- Firmware provides full Wi-Fi and networking stack services including TCP/UDP/IP, HTTP, DNS, DHCP and SSL
- 802.11i Security
  - WEP, WPA/WPA2 Personal
  - WPA/WPA2 Enterprise

## MODULE HIGHLIGHTS

- Single power source of 3.3V
- FCC/IC/ETSI, Wi-Fi Alliance Certified
- Rich I/O interfaces : SPI, UART, GPIO, I2C, ADC, JTAG



**GS1011M MODULE SPECIFICATIONS**

<b>Radio Protocol</b>	IEEE 802.11b (IEEE 802.11b/g/n Compatible)
<b>RF Output Power (Typical)</b>	8 dBm (GS1011Mlx) 18 dBm (GS1011MEx)
<b>RF Operating Frequency</b>	2.4 - 2.497 GHz
<b>Supported Data Rates</b>	11, 5.5, 2, 1 Mbps (802.11b)
<b>Antenna Options</b>	PCB Trace and u.FL connector for external antenna
<b>Operating Temperature</b>	Industrial (-40° to +85°C)
<b>Security Protocols</b>	WEP, WPA/WPA2 Personal WPA/WPA2 Enterprise (EAP-FAST, EAP-TLS, EAP-TTLS, PEAP v0/1)
<b>Networking Protocols</b>	UDP, TCP/IP (IPv4), DHCP, ARP, DNS, HTTP/HTTPS Client and Server
<b>Certifications and Compliance</b>	Wi-Fi, FCC, IC, ETSI, RoHS, Japan Pre-Scan
<b>I/O Interface</b>	UART (2), SPI (2), I2C, ADC (2), WAKE, ALARM (2), GPIOs, PWM, JTAG
<b>Dimensions</b>	GS1011Mlx = 1.28 in X 0.9 in (32.51 mm x 22.86 mm) GS1011MEx = 1.45 in X 0.9 in (36.83 mm x 22.86 mm)
<b>Power Source</b>	3.3V
<b>Standby Power (Typical)</b>	< 7uA * Lowest power state (RTC Active)

**GS1011M BLOCK DIAGRAM**

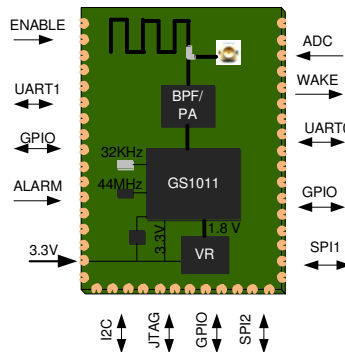

**TARGET APPLICATIONS**

GainSpan's GS1011 module is easily designed into embedded systems, allowing customers to develop a broad array of devices and appliances that will connect to the Internet. In applications such as healthcare and fitness, smart energy, industrial controls, commercial/building automation and consumer electronics.

