

CMD CONNECTOR SERIES

PCB Connectors



HYPERBOLOID TECHNOLOGY

Smiths Connectors offers an extensive range of superior contact technologies suitable for standard and custom solutions. Hypertac® (HYPERboloid CONTACT) is the original superior performing hyperboloid contact technology designed for use in all applications and in harsh and demanding environments where high reliability and safety are critical. The inherent electrical and mechanical characteristics of the Hypertac hyperboloid contact ensures unrivalled performance in terms of reliability, number of mating cycles, low contact force and minimal contact resistance. The shape of the contact sleeve is formed by hyperbolically arranged contact wires, which align themselves elastically as contact lines around the pin, providing a number of linear contact paths.

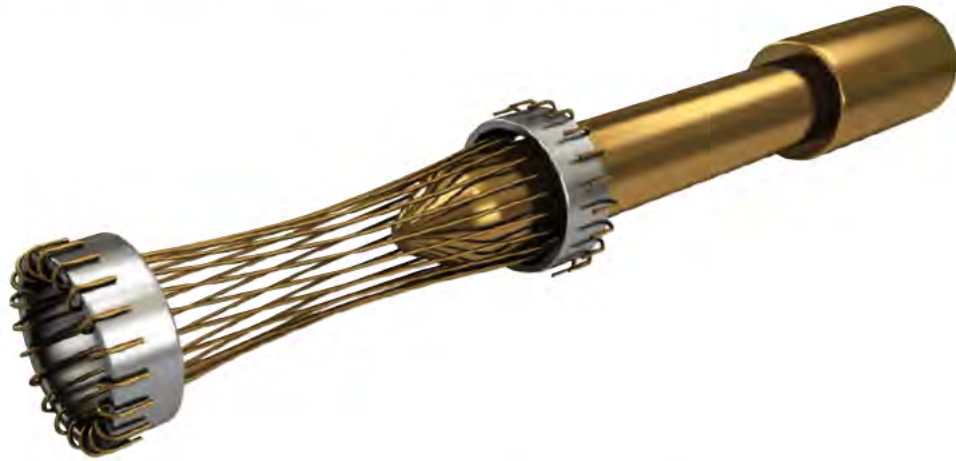

FEATURE

LOW INSERTION/EXTRACTION FORCES

The angle of the socket wires allows tight control of the pin insertion and extraction forces. The spring wires are smoothly deflected to make line contact with the pin.

LONG CONTACT LIFE

The smooth and light wiping action minimizes wear on the contact surfaces. Contacts perform up to 100,000 insertion/extraction cycles with minimal degradation in performance.

LOWER CONTACT RESISTANCE

The design provides a far greater contact area and the wiping action of the wires insures a clean and polished contact surface. Our contact technology has about half the resistance of conventional contact designs.

HIGHER CURRENT RATINGS

The design parameters of the contact (e.g., the number, diameter and angle of the wires) may be modified for any requirement. The number of wires can be increased so the contact area is distributed over a larger surface. Thus, the high current carried by each wire because of its intimate line contact, can be multiplied many times.

IMMUNITY TO SHOCK & VIBRATION

The low mass and resultant low inertia of the wires enable them to follow the most abrupt or extreme excursions of the pin without loss of contact. The contact area extends 360° around the pin and is uniform over its entire length. The 3 dimensional symmetry of the Hypertac contact design guarantees electrical continuity in all circumstances.

BENEFIT

HIGH DENSITY INTERCONNECT SYSTEMS

Significant reductions in size and weight of sub-system designs. No additional hardware is required to overcome mating and un-mating forces.

LOW COST OF OWNERSHIP

The Hypertac contact technology will surpass most product requirements, thus eliminating the burden and cost of having to replace the connector or the entire subsystem.

LOW POWER CONSUMPTION

The lower contact resistance of our technology results in a lower voltage drop across the connector reducing the power consumption and heat generation within the system.

MAXIMUM CONTACT PERFORMANCE

The lower contact resistance of the Hypertac contact reduces heat build-up; therefore Hypertac contacts are able to handle far greater current in smaller contact assemblies without the detrimental effects of high temperature.

RELIABILITY UNDER HARSH ENVIRONMENTS

Harsh environmental conditions require connectors that will sustain their electrical integrity even under the most demanding conditions such as shock and vibration. The Hypertac contact provides unmatched stability in demanding environments when failure is not an option.

TABLE OF CONTENTS

CMD SERIES

| | |
|---|----|
| ▶ Scope | 2 |
| ▶ Applied documents..... | 3 |
| ▶ Requirements..... | 3 |
| ▶ Quality assurance provisions..... | 5 |
| ▶ Packaging..... | 5 |
| ▶ Notes..... | 5 |
| ▶ Selection chart..... | 6 |
| ▶ Plug connector: 42, 82, 110, 126, 158 and 174 pin contact positions | 8 |
| ▶ Receptacle connector: 42, 82, 110, 126, 158 and 174 socket contact positions .. | 17 |
| ▶ Plug connector: 220, 236 and 316 pin contact positions | 26 |
| ▶ Receptacle connector: 220, 236 and 316 socket contact positions | 35 |
| ▶ Polarization configuration chart..... | 44 |
| ▶ Maximum dimensions of mated connectors | 45 |
| ▶ The connector halves mating..... | 50 |
| ▶ Connectors for measuring and yesy..... | 53 |
| ▶ Flex circuit soldering | 59 |

1. SCOPE

1.1 Scope

This Design covers CMD Connectors Family, plug and receptacle style, with 42, 82, 110, 126, 158, 174, 220, 236 and 316 pin or socket contact positions, conforming to MIL-C-55302. Contact arrangement is offset-grid pattern within dielectric connector body with four rows, .075 in (1.905 mm) center-to-center contact spacing in each row, and .075 in (1.905 mm) row-to-row spacing. Contact size is 0.6 mm nominal pin DIA. Polarization feature is incorporated in each connector assembly to assure correct insertion. Coding key system provides 36 possible keying combinations. There are available, moreover, suitable dielectric connector body cavities aimed at ground contacts, shielded contacts, co-axial contacts, databus contacts, fiber optic termini, etc.

1.2 Contact terminal types

1.2.1 Plug connector, pin contacts equipped, contact terminal types available are:

- a. solder post, thru hole, as dip solder right angle contact terminal for rigid PCB, (daughterboard application, or in line arrangement board-to-board connection);
- b. solder post, thru hole, as dip solder straight contact terminal for rigid PCB, (in parallel arrangement board-to-board connection);
- c. solder tail, as surface mount contact terminal for rigid PWB, when plug connector is assembled with proper flex-circuit conforming to MIL-P-50884, and its surface mount tails are the contact terminals for straddle mount, (daughterboard application, or in line arrangement board-to-board connection).

1.2.2 Receptacle connector, socket contact equipped, contact terminal types available are:

- a. solder post, thru hole, as dip solder straight contact terminal for rigid PWB, (motherboard application, or in parallel arrangement board-to-board connection);
- b. solder post, thru hole, as dip solder right angle contact terminal for rigid PCB, (in line arrangement board-to-board connection);
- c. wire wrap post, as solderless contact terminal in accordance with MIL-STD-1130, (backplane attachment);
- d. solder tail, as surface mount contact terminal for rigid PCB, when receptacle connector is assembled with proper flex-circuit conforming to MIL-P-50884, and its surface mount tails are the contact terminals for straddle mount, (in line arrangement board-to-board connection).

1.3 Plug and receptacle connectors for measuring and test devices available are:

- a. plug and receptacle connector for extender board, (as rigid vehicle for measuring and test devices);
- b. plug and receptacle connector for cable assembly, (as flexible vehicle for measuring and test devices);
- c. card edge receptacle test connector and its proper plug connector, (for measuring and test devices).

2. APPLIED DOCUMENTS

2.1 Applied documents

CMD Connectors Family is designed, manufactured, tested and delivered in accordance with the documents listed below. The latest issue of the following documents, documents amendments and notices, in being on 30 June 1994 are used unless otherwise specified in this Design.

| | |
|--------------|--|
| MIL-C-26074 | Coatings, electroless nickel requirement for. |
| MIL-I-46058 | Insulating compound, electrical (for coating printed circuit assemblies). |
| MIL-P-50884 | Printed-wiring, flexible and rigid-flex. |
| MIL-C-55302 | Connectors, printed circuit subassembly and accessories. |
| MIL-I-81550 | Insulating compound electrical, embedding, reversion resistant silicone. |
| MIL-STD-1130 | Connections, electrical, solderless wrapped. |
| MIL-STD-2118 | Flexible and rigid-flex printed-wiring for electronic equipment design requirements for. |
| MS21209 | Insert, screw thread, coarse and fine, screw locking, helical coil, cres. |

3. REQUIREMENTS

3.1 Connector body is an insulator body of molded one-piece construction.

3.1.1 Connector body material is injection molded from glass reinforced polyphenylene sulfide (PPS) type GST-40F per MIL-M-24519 and in accordance with MIL-C-55302. This thermoplastic compound is flame resistant, having flammability rating V-O/5VA, without additives, per UL94.

3.2 Pin contact and contact terminal

3.2.1 Pin contact and dip solder, (right angle and straight), contact terminal are screw machined, and one-piece construction.

3.2.1.1 Pin contact and dip solder, (right angle and straight), contact terminal materials are beryllium-copper alloy per QQ-C-530, (ASTM B197), with protective finishing of gold plate, over suitable underplate, as specified in MIL-C-55302.

3.2.2 Pin contact and crimp contact terminal are screw machined, one-piece construction.

3.2.2.1 Pin contact and crimp contact terminal materials are copper-alloy per QQ-B-626, (ASTM B16), with protective finishing of gold plate, over suitable underplate, as specified in MIL-C-55302.

3.2.3 Pin contact and its surface mount tail terminal are two-pieces construction type. These two-parts are assembled in one-piece construction using a suitable tin-lead soldering.

3.2.3.1 Pin contact and its surface mount tail terminal materials. Pin contact screw machined from copper-alloy per QQ-B-626, (ASTM B16), with protective finishing of gold plate, over suitable underplate, as specified in MIL-C-55302. The surface mount tail terminal is the part of a proper flex-circuit conforming to MIL-P-50884 with tail finishing of tin-lead (50÷70%) composition, .50 to .80 mil (12 to 20 µm) thick, per MIL-P-81728. Pin contact is soldered with flex-circuit, as its contact terminal, using solder alloy composition Sn63 conforming to QQ-S-571.

3.3 Socket contact and contact terminal

Socket contact is HYPERTAC and contact terminal types are: dip solder, (straight and right angle), wire wrappost, surface mount tail, and crimp.

3.3.1 Socket contact materials

HYPERTAC springs are wiredrawn from beryllium-copper alloy per QQ-C-530, (ASTM B197). Socket contact body is screw machined from copper-alloy per QQ-B-626, (ASTM B16). Protective finishing is gold plate, over suitable underplate, as specified in MIL-C-55302.

3.3.2 Dip solder, (straight and right angle), wire wrappost, and crimp socket contact terminals are screw machined, one-piece construction.

3.3.2.1 Dip solder, (straight and right angle), wire wrappost, and crimp socket contact terminal materials are proper copper-alloys in accordance with MIL-C-55302, with protective finishing of gold plate, over suitable underplate, as specified in MIL-C-55302.

3.3.3 Socket contact surface mount tail terminal is two-pieces construction type. These two-parts are assembled in one-piece construction using a suitable tin-lead soldering.

3.3.3.1 Socket contact end and its surface mount tail terminal materials.

Socket contact end is screw machined from copper-alloy per QQ-B-626, (ASTM B16), with finishing of tin-lead (50÷70%) composition per MIL-P-81728 over nickel underplate per QQ-N-290. The surface mount tail terminal is the part of a proper flex-circuit conforming to MIL-P-50884 with tail finishing of tin-lead (50÷70%) composition, .50 to .80 mil (12 to 20 µmm) thick, per MIL-P-81728. Socket contact end is soldered with flex-circuit, as its contact terminal, using solder alloy composition Sn63 conforming to QQ-S-571.

3.4 Connector hardware is formed by male guide pins plus female guide sockets (polarized, unpolarized and omnipolarized types), mounting hardware, and joining devices.

3.4.1 Connector hardware materials

Male guide pins are screw machined from stainless steel per ASTM A582, (AISI 303), and passivated per QQ-P-35. Female guide sockets, (polarized, unpolarized and omnipolarized types), are screw machined from beryllium-copper alloy per QQ-C-530, (ASTM B196), and nickel plated per QQ-N-290. Mounting hardware is machined from aluminum alloy per QQ-A-250/4 and finished with electroless nickel coating per MIL-C-26074. Joining devices are machined from corrosion-resistant steel per QQ-S-766, (ASTM A666), and passivated per QQ-P-35. Threaded inserts, self-locking type, are conforming to MS21209.

3.4.2 Polarization guide set provides 36 possible polarized position combinations; plus unpolarized male guide pins on plug connector, and omnipolarized female guide sockets on receptacle connector for measuring and test devices, (i.e. extender board applications), as shown on page 44 of this catalog.

3.5 Design and construction of CMD Connectors Family are in accordance with MIL-C-55302 requirements.

3.6 CMD Connectors Family requirements are:

- contact engagement and separation forces: maximum engagement force =100 g (3.53 oz); minimum separation force =14 g (.49 oz);
- connector mating and unmating forces: maximum mating force =60 g (2.12 oz) multiplied by number of contacts; minimum unmating force =20 g (.71 oz) multiplied by number of contacts;
- contact current rating: the connector may have any combination of current flow and ambient temperature provided the contact or connector temperature does not exceed 125 °C. If mated plug and receptacle connectors are both equipped with dip solder, or wire wrappost, or crimp as contact terminals, the test current is 3.0 A for individually connected contact, and 2.0 A for series wired contacts; if mated plug and receptacle connectors are, one of them or both of them, assembled with flex-circuit as surface mount tail contact terminals, test current is 1.5 A for individually connected contact, and 1.0 A for series wired contacts, in accordance with MIL-STD-2118.
- mated contact resistance: 5.0 mΩ maximum individual, if pin and socket contacts have dip solder, or wire wrappost, or crimp as contact terminals; the flex-circuit resistance plus the soldering resistance, (namely surface mount tail terminal resistance), is 4.0 mΩ maximum individual; the total resistance equals the surface mount tail terminal resistance plus the mated contact resistance;
- temperature range: normal operating temperature is between -65 °C and +125 °C;
- dielectric withstanding voltage: 750 VRMS, 60 Hz at sea level, 250 VRMS, 60 Hz at 70,000 feet (21,336 m), when flex-circuit and its surface mount tails are conformally coated of a suitable electrical insulating compound as specified in MIL-I-46058;
- insulation resistance is $\geq 5000 \text{ M}\Omega$ at 500 VDC;
- contact life: 30,000 insertion and withdrawal cycles, with minimum wear;
- vibration: when tested in accordance with MIL-C-55302, and MIL-STD-1344 method 2005, 10-2000 Hz, 15 G peak, 4 h per axis, 100 mA, there are no interruption in continuity greater than 2 ns of the test circuit which incorporates mated contacts;
- shock: when tested in accordance with MIL-C-55302, and MIL-STD-1344 method 2004, 6 ms, 100 G sawtooth, six shocks, 100 mA, there are no interruption in continuity greater than 2 ns of the test circuit which incorporates mated contacts;
- solderability: in accordance with MIL-STD-202 method 208 at a uniform temperature of 245 °C for 5 s;
- resistance to soldering heat: in accordance with MIL-STD-202 method 210 condition C, 260 °C for 10 s;
- capacitance: contact to contact maximum 2.0 pF;
- calculated inductance: maximum 15 nH

4. QUALITY ASSURANCE PROVISIONS

CMD Connectors Family is inspected using data values of Section 3 of this Design, and examinations and test methods in accordance with MIL-C-55302.

5. PACKAGING

5.1 Packaging requirements are in accordance with “CONNEI ‘s Packaging Procedures”, and then packaging is adequate to provide protection against any damage, breakage, or loss during shipment from the supply source to the ultimate using activity.

6. NOTES

6.1 Intended use

CMD Connectors Family is designed for printed wiring board-to-printed wiring board, or printed wiring board-to-cable interconnection, of high density electronic packaging equipment subassemblies with low-power requirements.

▶ SELECTION CHART

BODY CONNECTOR DIMENSIONS

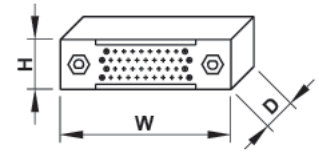

| Connector figure (mating face) | W max (mm) | H max (mm) | D max (mm) |
|-----------------------------------|---------------|---------------|--|
| | 37.210 | 10.90 | 10.61 ⁽¹⁾ 19.40 ⁽²⁾ |
| | | | 8.00 |
| | 56.260 | 10.90 | 10.61 ⁽¹⁾ 19.40 ⁽²⁾ |
| | | | 8.00 |
| | 69.595 | 10.90 | 10.61 ⁽¹⁾ 19.40 ⁽²⁾ |
| | | | 8.00 |
| | 77.215 | 10.90 | 10.61 ⁽¹⁾ 19.40 ⁽²⁾ |
| | | | 8.00 |
| | 92.455 | 10.90 | 10.61 ⁽¹⁾ 19.40 ⁽²⁾ |
| | | | 8.00 |
| | 100.075 | 10.90 | 10.61 ⁽¹⁾ 19.40 ⁽²⁾ |
| | | | 8.00 |
| | 128.650 | 10.90 | 10.61 ⁽¹⁾ 19.40 ⁽²⁾ |
| | | | 8.00 |
| | 136.270 | 10.90 | 10.61 ⁽¹⁾ 19.40 ⁽²⁾ |
| | | | 8.00 |
| | 174.370 | 10.90 | 10.61 ⁽¹⁾ 19.40 ⁽²⁾ |
| | | | 8.00 |

⁽¹⁾ Applicable to plug connector body equipped with dip solder, straight thru, contact terminal.

⁽²⁾ Applicable to plug connector body equipped with all the other contact terminal styles.

| Contact positions | Connector style | Contact terminal types available are: | | | | See pages |
|-------------------|---|---------------------------------------|---------------|--------------------|----------------|-----------|
| | | Dip solder | | Surface mount tail | Wire wrap post | |
| | | (Straight thru) | (Right angle) | | | |
| 42 | Plug connector pin contacts equipped | Yes | Yes | Check Firm | No | 10 to 17 |
| | Receptacle connector socket contacts equipped | Yes | Yes | Check Firm | Yes | 18 to 27 |
| 82 | Plug connector pin contacts equipped | Yes | Yes | Check Firm | No | 10 to 17 |
| | Receptacle connector socket contacts equipped | Yes | Yes | Check Firm | Yes | 18 to 27 |
| 110 | Plug connector pin contacts equipped | Yes | Yes | Yes | No | 10 to 17 |
| | Receptacle connector socket contacts equipped | Yes | Yes | Yes | Yes | 18 to 27 |
| 126 | Plug connector pin contacts equipped | Yes | Yes | Check Firm | No | 10 to 17 |
| | Receptacle connector socket contacts equipped | Yes | Yes | Check Firm | Yes | 18 to 27 |
| 158 | Plug connector pin contacts equipped | Yes | Yes | Yes | No | 10 to 17 |
| | Receptacle connector socket contacts equipped | Yes | Yes | Yes | Yes | 18 to 27 |
| 174 | Plug connector pin contacts equipped | Yes | Yes | Yes | No | 10 to 17 |
| | Receptacle connector socket contacts equipped | Yes | Yes | Yes | Yes | 18 to 27 |
| 220 | Plug connector pin contacts equipped | Check Firm | Yes | Check Firm | No | 28 to 36 |
| | Receptacle connector socket contacts equipped | Yes | Yes | Check Firm | Yes | 37 to 45 |
| 236 | Plug connector pin contacts equipped | Check Firm | Yes | Yes | No | 28 to 36 |
| | Receptacle connector socket contacts equipped | Yes | Yes | Yes | Yes | 37 to 45 |
| 316 | Plug connector pin contacts equipped | Check Firm | Yes | Yes | No | 28 to 36 |
| | Receptacle connector socket contacts equipped | Yes | Yes | Yes | Yes | 37 to 45 |

► **PLUG CONNECTOR:
42, 82, 110, 126, 158 AND 174 PIN CONTACT POSITIONS**

TABLE I

| Dimensions in width | | | |
|---------------------|---------|--------|--------|
| Contact positions | A (mm) | B (mm) | C (mm) |
| 42 | 37.210 | 29.210 | 19.050 |
| 82 | 56.260 | 48.260 | 38.100 |
| 110 | 69.595 | 61.595 | 51.435 |
| 126 | 77.215 | 69.215 | 59.055 |
| 158 | 92.455 | 84.455 | 74.295 |
| 174 | 100.075 | 92.075 | 81.915 |

TABLE II

| Contact positions | Weight* in grams (with g=9.81 m/s ²) | | * According to contacts terminal length, and with D-shaped guide pins installed |
|-------------------|---|------|---|
| | from | to | |
| 42 | 7.5 | 8.0 | |
| 82 | 11.0 | 11.5 | |
| 110 | 13.5 | 14.0 | |
| 126 | 15.5 | 16.0 | |
| 158 | 17.5 | 18.0 | |
| 174 | 19.0 | 20.0 | |

NOTES

1. Dimensions for user installation purpose only.
2. Dimensions are in millimeters.
3. Dimensions in width of these connectors are specified in the table I of this page.
4. Materials, finishes and connectors requirements are described into this catalog. Hot solder dipping, as dip solder terminal end finishing, is available at Customer request, (please consult the Factory).
5. These plug connectors are conforming to MIL-C-55302.
6. These plug connectors mate CMD***EF***H receptacle connectors, (see pages 17 to 24), when both of them, (plug and receptacle), are equipped with the same contact positions number, appropriate hardware, and identical polarizing combination.
7. Weights of these connectors are specified in the table II of this page.
8. Connectors for measuring and test devices, (i.e. extender board applications), are indicated on pages 53 to 58.

▶ HOW TO ORDER

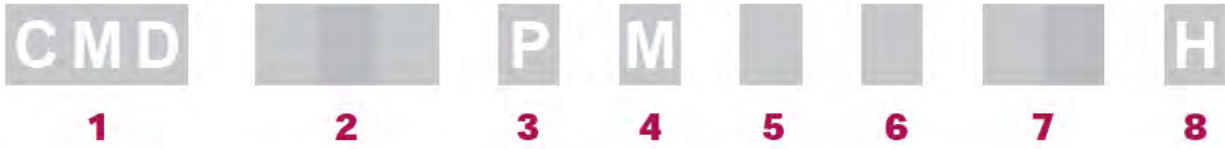

1 ▶ CONNECTOR FAMILY

2 ▶ CONNECTOR SIZE

- 0 4 2** 42 CONTACT POSITIONS **0 8 2** 82 CONTACT POSITIONS **1 1 0** 110 CONTACT POSITIONS
- 1 2 6** 126 CONTACT POSITIONS **1 5 8** 158 CONTACT POSITIONS **1 7 4** 174 CONTACT POSITIONS

3 ▶ CONNECTOR STYLE

- P** PLUG CONNECTOR

4 ▶ CONTACT STYLE

- M** PIN CONTACT

5 ▶ CONTACT TERMINAL STYLE *Dip solder, right angle, with:*

- A** .109 INCH (2.76 MM) LONG DIP **B** .140 INCH (3.55 MM) LONG DIP **C** .172 INCH (4.37 MM) LONG DIP

6 ▶ HARDWARE CODE

- Y** D-SHAPED GUIDE PINS **P** UNIVERSAL COUPLING GUIDE PINS *(for test type connectors)*

7 ▶ HARDWARE POLARIZATION

- 0 0** WHEN D-SHAPED GUIDE PINS ARE INSTALLED IN THE 01 POLARIZED POSITION, *(see polarization configuration chart on page 44)*, WITHOUT LOCTITE 242 APPLIED.
- 0 1** TO **3 6** WHEN D-SHAPED GUIDE PINS ARE INSTALLED IN THE PROPER POLARIZED POSITION AND LOCTITE 242 IS APPLIED TO THE THREADS, *(see polarization configuration chart on page 44)*.
- 3 7** WHEN UNIVERSAL COUPLING GUIDE PINS, *(for test type connectors)*, ARE INSTALLED.
- 3 8** WHEN D-SHAPED GUIDE PINS OR UNIVERSAL COUPLING GUIDE PINS *(for test type connectors)*, ARE SHIPPED LOOSE IN A PLASTIC BAG.

8 ▶ CONTACT FINISHING

- H** CONTACTS WITH PLATING AND UNDERPLATING CONFORMING TO MIL-C-55302

► **PLUG CONNECTOR:**
42, 82, 110, 126, 158 AND 174 PIN CONTACT POSITIONS

**PLUG CONNECTOR: 42, 82, 110, 126, 158 AND 174 PIN CONTACT POSITIONS,
 .075 INCH SPACING (1.905 MM), DIP SOLDER (STRAIGHT) TERMINAL STYLE**

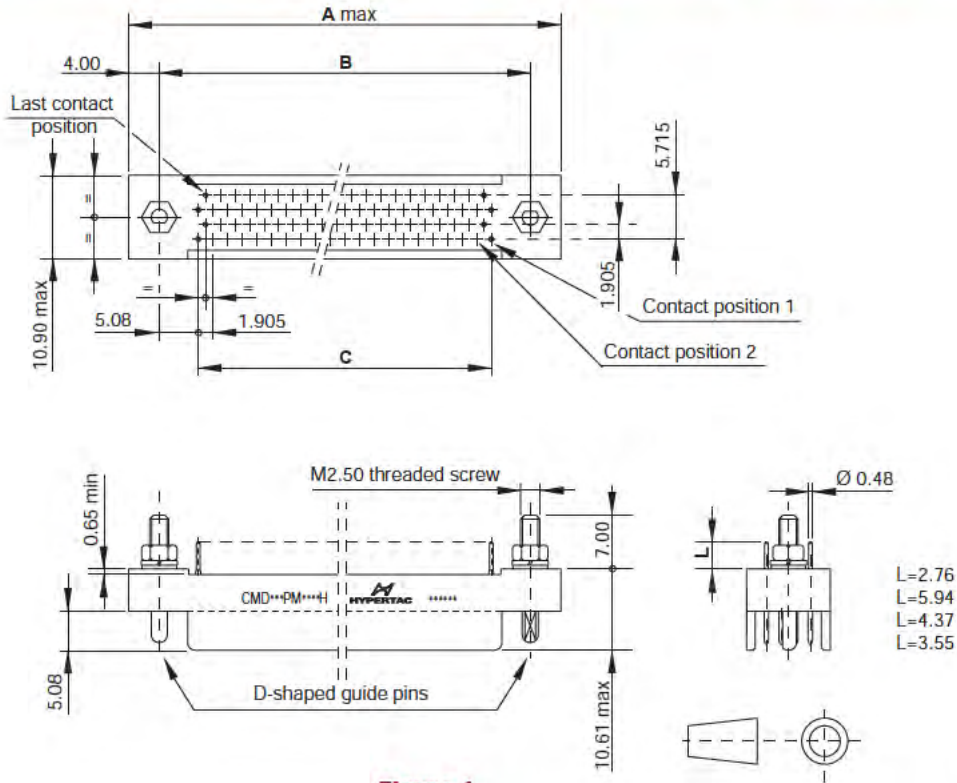

Figure 4

**MOUNTING PATTERN, IN PARALLEL ARRANGEMENT BOARD-TO-BOARD CONNECTION,
 (RECOMMENDED PCB HOLE CONFIGURATION)**

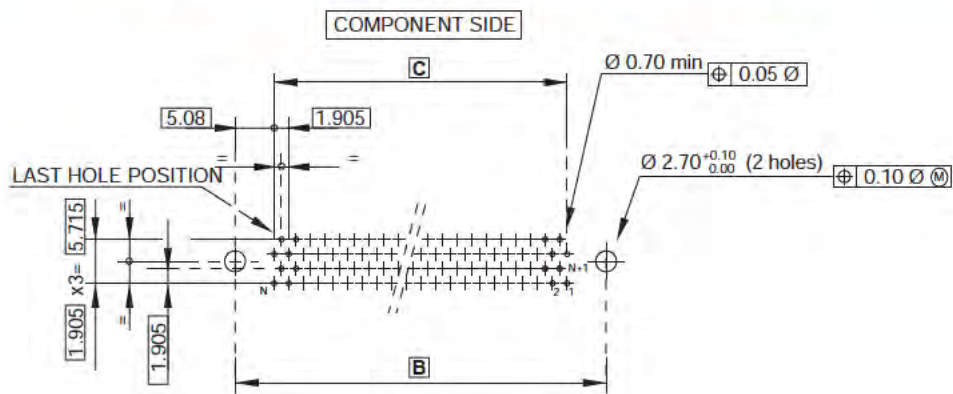

Figure 5

► **PLUG CONNECTOR:
42, 82, 110, 126, 158 AND 174 CONTACT POSITIONS**

TABLE I

| Dimensions in width | | | |
|---------------------|---------|--------|--------|
| Contact positions | A (mm) | B (mm) | C (mm) |
| 42 | 37.210 | 29.210 | 19.050 |
| 82 | 56.260 | 48.260 | 38.100 |
| 110 | 69.595 | 61.595 | 51.435 |
| 126 | 77.215 | 69.215 | 59.055 |
| 158 | 92.455 | 84.455 | 74.295 |
| 174 | 100.075 | 92.075 | 81.915 |

TABLE II

| Contact positions | Weight* in grams (with g=9.81 m/s ²) | | * According to contacts terminal length, and with D-shaped guide pins installed |
|-------------------|---|------|---|
| | from | to | |
| 42 | 5.5 | 6.5 | |
| 82 | 8.0 | 9.0 | |
| 110 | 9.5 | 10.5 | |
| 126 | 10.5 | 11.5 | |
| 158 | 12.0 | 13.0 | |
| 174 | 13.0 | 14.0 | |

NOTES

1. Dimensions for User installation purpose only.
2. Dimensions are in millimeters.
3. Dimensions in width of these connectors are specified in the table I of this page.
4. Materials, finishes and connectors requirements are described into this catalog. Hot solder dipping, as dip solder terminal end finishing, is available at Customer request, (please consult the Factory).
5. These plug connectors are conforming to MIL-C-55302.
6. These plug connectors mate CMD***EF****H receptacle connectors, (see pages 17 to 24), when both of them, (plug and receptacle), are equipped with the same contact positions number, appropriate hardware, and identical polarizing combination.
7. Weights of these connectors are specified in the table II of this page.
8. Connectors for measuring and test devices, (i.e. extender board applications), are indicated on pages 53 to 58.

▶ HOW TO ORDER



1 ▶ CONNECTOR FAMILY

2 ▶ CONNECTOR SIZE

0 4 2 42 CONTACT POSITIONS 0 8 2 82 CONTACT POSITIONS 1 1 0 110 CONTACT POSITIONS
 1 2 6 126 CONTACT POSITIONS 1 5 8 158 CONTACT POSITIONS 1 7 4 174 CONTACT POSITIONS

3 ▶ CONNECTOR STYLE

P PLUG CONNECTOR

4 ▶ CONTACT STYLE

M PIN CONTACT

5 ▶ CONTACT TERMINAL STYLE *Dip solder, straight thru, with:*

D .109 INCH (2.76 MM) LONG DIP E .140 INCH (3.55 MM) LONG DIP
 G .172 INCH (4.37 MM) LONG DIP L .234 INCH (5.94 MM) LONG DIP

6 ▶ HARDWARE CODE

Y D-SHAPED GUIDE PINS P UNIVERSAL COUPLING GUIDE PINS *(for test type connectors)*

7 ▶ HARDWARE POLARIZATION

0 1 TO 3 6 WHEN D-SHAPED GUIDE PINS ARE INSTALLED IN THE PROPER POLARIZED POSITION
(see polarization configuration chart on page 44).

3 7 WHEN UNIVERSAL COUPLING GUIDE PINS, *(for test type connectors)*, ARE INSTALLED.

3 8 WHEN D-SHAPED GUIDE PINS OR UNIVERSAL COUPLING GUIDE PINS *(for test type connectors)*, ARE SHIPPED LOOSE
 IN A PLASTIC BAG.

8 ▶ CONTACT FINISHING

H CONTACTS WITH PLATING AND UNDERPLATING CONFORMING TO MIL-C-55302

► **PLUG CONNECTOR:**
42, 82, 110, 126, 158 AND 174 PIN CONTACT POSITIONS

**PLUG CONNECTOR: 42, 82, 110, 126, 158 AND 174 CONTACT POSITIONS,
 .075 INCH SPACING (1.905 MM), BOARD PACKAGE THICKNESS FROM 1.00 TO 4.20 MM**

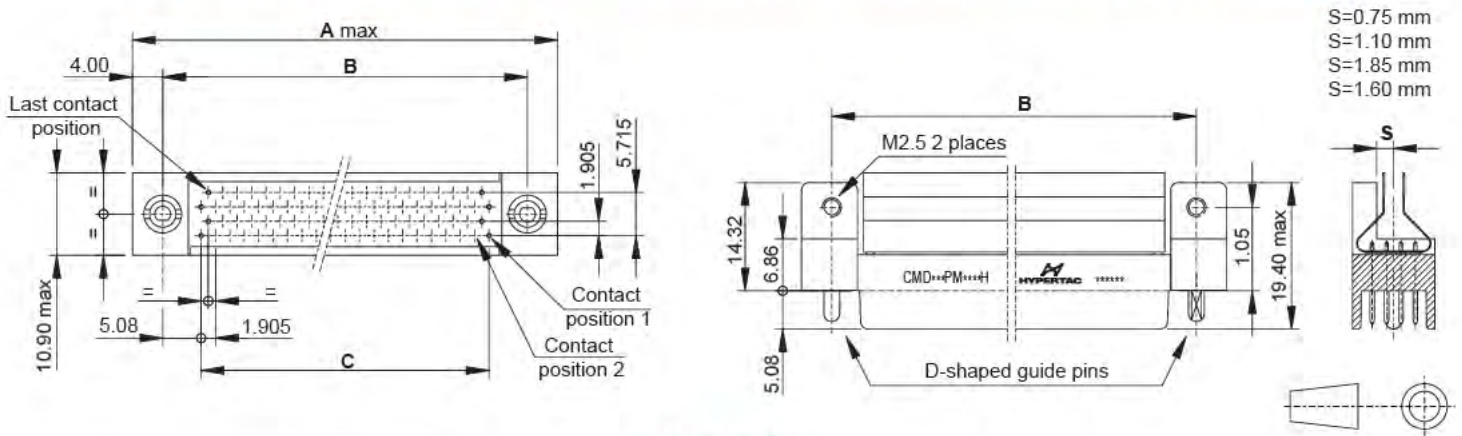

Figure 6

CONTACT PATTERN NUMBERING

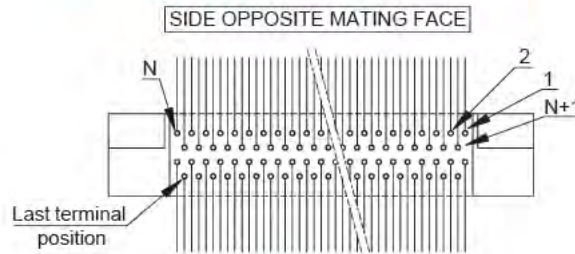

Figure 7

TABLE I

| Dimensions in width | | | |
|---------------------|---------|--------|--------|
| Contact positions | A (mm) | B (mm) | C (mm) |
| 42 | 37.210 | 29.210 | 19.050 |
| 82 | 56.260 | 48.260 | 38.100 |
| 110 | 69.595 | 61.595 | 51.435 |
| 126 | 77.215 | 69.215 | 59.055 |
| 158 | 92.455 | 84.455 | 74.295 |
| 174 | 100.075 | 92.075 | 81.915 |

TABLE II

| Contact positions | Weight* in grams (with g=9.81 m/s ²) | | * According to variations of soldering and insulating compound weight, and with D-shaped guide pins installed |
|-------------------|---|------|---|
| | from | to | |
| 42 | 8.0 | 9.0 | |
| 82 | 11.5 | 12.5 | |
| 110 | 13.5 | 14.5 | |
| 126 | 15.0 | 16.0 | |
| 158 | 17.5 | 18.5 | |
| 174 | 18.5 | 19.5 | |

► **PLUG CONNECTOR:
42, 82, 110, 126, 158 AND 174 PIN CONTACT POSITIONS**

MOUNTING PATTERN, DAUGHTERBOARD APPLICATION

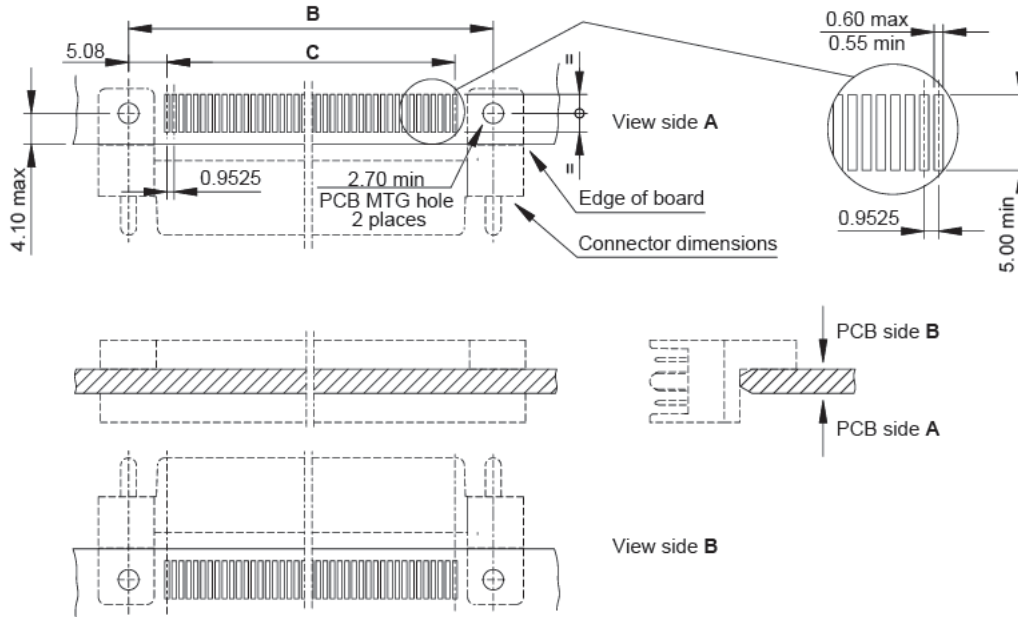

Figure 8

NOTES

1. Dimensions for User installation purpose only.
2. Dimensions are in millimeters.
3. Dimensions in width of these connectors are specified in the table I of the previous page.
4. Materials, finishes and connectors requirements are described into this catalog.
5. These plug connectors are conforming to MIL-C-55302, and their flex circuits, as surfacemount tail terminals, are in accordance with MIL-P-50884.
6. These plug connectors mate CMD***EF****H receptacle connectors, (see pages 17 to 24), when both of them, (plug and receptacle), are equipped with the same contact positions number, appropriate hardware, and identical polarizing combination.
7. Weights of these connectors are specified in the table II of the previous page.
8. Connectors for measuring and test devices, (i.e. extender board applications), are indicated on pages 53 to 58.

▶ HOW TO ORDER



1 ▶ CONNECTOR FAMILY

2 ▶ CONNECTOR SIZE

CHECK FIRM 42 CONTACT POSITIONS CHECK FIRM 82 CONTACT POSITIONS **110** 110 CONTACT POSITIONS
 CHECK FIRM 126 CONTACT POSITIONS **158** 158 CONTACT POSITIONS **174** 174 CONTACT POSITIONS

3 ▶ CONNECTOR STYLE

P PLUG CONNECTOR

4 ▶ CONTACT STYLE

M PIN CONTACT

5 ▶ CONTACT TERMINAL STYLE *Flex circuit for straddle mount, with board package thickness:*

N FROM .039 TO 0.79 INCH (FROM 1.00 TO 2.00 MM) **R** FROM .067 TO .106 INCH (FROM 1.70 TO 2.70 MM)
T FROM .106 TO .146 INCH (FROM 2.70 TO 3.70 MM) **V** FROM .126 TO .165 INCH (FROM 3.20 TO 4.20 MM)

6 ▶ HARDWARE CODE

Y D-SHAPED GUIDE PINS **P** UNIVERSAL COUPLING GUIDE PINS (*for test type connectors*)

7 ▶ HARDWARE POLARIZATION

- 00** WHEN D-SHAPED GUIDE PINS ARE INSTALLED IN THE 01 POLARIZED POSITION, (*see polarization configuration chart on page 44*), WITHOUT LOCTITE 242 APPLIED.
- 01** TO **36** WHEN D-SHAPED GUIDE PINS ARE INSTALLED IN THE PROPER POLARIZED POSITION AND LOCTITE 242 IS APPLIED TO THE THREADS, (*see polarization configuration chart on page 44*).
- 37** WHEN UNIVERSAL COUPLING GUIDE PINS, (*for test type connectors*), ARE INSTALLED.
- 38** WHEN D-SHAPED GUIDE PINS OR UNIVERSAL COUPLING GUIDE PINS (*for test type connectors*), ARE SHIPPED LOOSE IN A PLASTIC BAG.

8 ▶ CONTACT FINISHING

H CONTACTS WITH PLATING AND UNDERPLATING CONFORMING TO MIL-C-55302

► **RECEPTACLE CONNECTOR:
42, 82, 110, 126, 158 AND 174 SOCKET CONTACT POSITIONS**

TABLE I

| Dimensions in width | | | | |
|---------------------|---------|--------|--------|--------|
| Contact positions | A (mm) | B (mm) | C (mm) | D (mm) |
| 42 | 37.210 | 29.210 | 19.050 | 22.50 |
| 82 | 56.260 | 48.260 | 38.100 | 41.60 |
| 110 | 69.595 | 61.595 | 51.435 | 54.90 |
| 126 | 77.215 | 69.215 | 59.055 | 62.50 |
| 158 | 92.455 | 84.455 | 74.295 | 77.90 |
| 174 | 100.075 | 92.075 | 81.915 | 85.40 |

TABLE II

| Contact positions | Weight* in grams (with g=9.81 m/s ²) | | * According to contacts terminal length (straight type), and with D-shaped guide socket installed |
|-------------------|---|------|---|
| | from | to | |
| 42 | 7.5 | 8.0 | |
| 82 | 11.0 | 11.5 | |
| 110 | 13.5 | 14.0 | |
| 126 | 15.5 | 16.0 | |
| 158 | 17.5 | 18.0 | |
| 174 | 19.0 | 20.0 | |

NOTES

1. Dimensions for user installation purpose only.
2. Dimensions are in millimeters.
3. Dimensions in width of these connectors are specified in the table I of this page.
4. Materials, finishes and connectors requirements are described into this catalog. Hot solder dipping, as dip solder terminal end finishing, is available at Customer request, (please consult the Factory).
5. These receptacle connectors are conforming to MIL-C-55302.
6. These receptacle connectors mate CMD***PM***H plug connectors, (see pages 8 to 16), when both of them, (receptacle and plug), are equipped with the same contact positions number, appropriate hardware, and identical polarizing combination.
7. Weights of these connectors are specified in the table II of this page.
8. Connectors for measuring and test devices, (i.e. extender board applications), are indicated on pages 53 to 58.

▶ HOW TO ORDER



1 ▶ CONNECTOR FAMILY

2 ▶ CONNECTOR SIZE

0 4 2 42 CONTACT POSITIONS
 0 8 2 82 CONTACT POSITIONS
 1 1 0 110 CONTACT POSITIONS
1 2 6 126 CONTACT POSITIONS
 1 5 8 158 CONTACT POSITIONS
 1 7 4 174 CONTACT POSITIONS

3 ▶ CONNECTOR STYLE

E RECEPTACLE CONNECTOR

4 ▶ CONTACT STYLE

F SOCKET CONTACT

5 ▶ CONTACT TERMINAL STYLE *Dip solder, straight thru, with:*

D .109 INCH (2.76 MM) LONG DIP
 E .140 INCH (3.55 MM) LONG DIP
G .172 INCH (4.37 MM) LONG DIP
 L .234 INCH (5.94 MM) LONG DIP

Wire wrap with:

Y .625 INCH (15.875 MM) LONG POST

6 ▶ HARDWARE CODE

Y D-SHAPED GUIDE SOCKETS
 P UNIVERSAL COUPLING GUIDE SOCKETS *(for test type connectors)*

7 ▶ HARDWARE POLARIZATION

0 1 TO 3 6 WHEN D-SHAPED GUIDE SOCKETS ARE INSTALLED IN THE PROPER POLARIZED POSITION
(see polarization configuration chart on page 44).

3 7 WHEN UNIVERSAL COUPLING GUIDE SOCKETS, *(for test type connectors)*, ARE INSTALLED.

3 8 WHEN D-SHAPED GUIDE SOCKETS OR UNIVERSAL COUPLING GUIDE SOCKETS *(for test type connectors)*, ARE SHIPPED LOOSE IN A PLASTIC BAG.

8 ▶ CONTACT FINISHING

H CONTACTS WITH PLATING AND UNDERPLATING CONFORMING TO MIL-C-55302

▶ **RECEPTACLE CONNECTOR:
42, 82, 110, 126, 158 AND 174 SOCKET CONTACT POSITIONS**

**RECEPTACLE CONNECTOR: 42, 82, 110, 126, 158 AND 174 SOCKET CONTACT POSITIONS,
.075 INCH SPACING (1.905 MM), BOARD PACKAGE THICKNESS FROM 1.00 TO 4.20 MM**

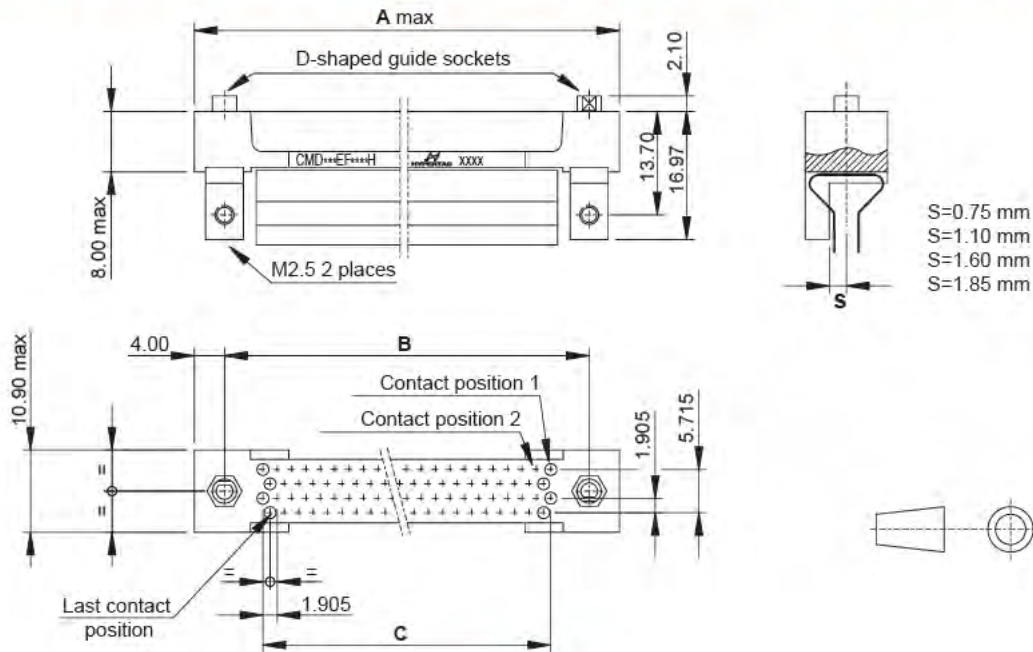

Figure 12

CONTACT PATTERN NUMBERING

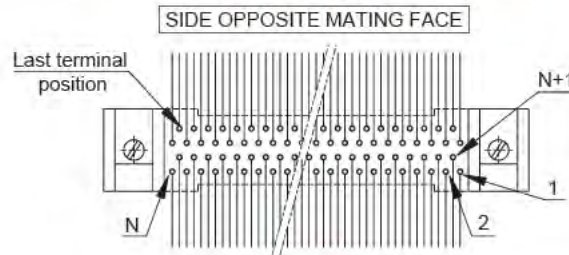

Figure 13

TABLE I

| Dimensions in width | | | |
|---------------------|---------|--------|--------|
| Contact positions | A (mm) | B (mm) | C (mm) |
| 42 | 37.210 | 29.210 | 19.050 |
| 82 | 56.260 | 48.260 | 38.100 |
| 110 | 69.595 | 61.595 | 51.435 |
| 126 | 77.215 | 69.215 | 59.055 |
| 158 | 92.455 | 84.455 | 74.295 |
| 174 | 100.075 | 92.075 | 81.915 |

TABLE II

| Contact positions | Weight* in grams (with g=9.81 m/s ²) | | * According to variations of soldering and insulating compound weight, and with D-shaped guide sockets installed |
|-------------------|---|------|--|
| | from | to | |
| 42 | 10.5 | 11.5 | |
| 82 | 14.0 | 15.0 | |
| 110 | 16.5 | 17.5 | |
| 126 | 18.5 | 19.5 | |
| 158 | 20.5 | 21.5 | |
| 174 | 22.0 | 23.0 | |

► **RECEPTACLE CONNECTOR:
42, 82, 110, 126, 158 AND 174 SOCKET CONTACT POSITIONS**

MOUNTING PATTERN, DAUGHTERBOARD APPLICATION

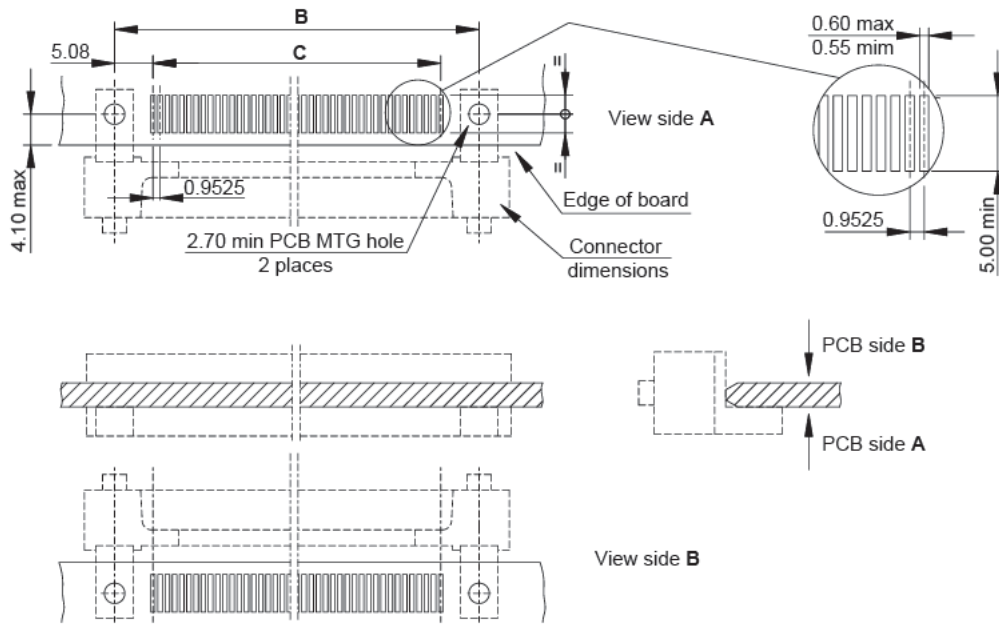

Figure 14

NOTES

1. Dimensions for user installation purpose only.
2. Dimensions are in millimeters.
3. Dimensions in width of these connectors are specified in the table I of the previous page.
4. Materials, finishes and connectors requirements are described into this catalog.
5. These receptacle connectors are conforming to MIL-C-55302, and their flex-circuits, as surface mount tail terminals, are in accordance with MIL-P-50884.
6. These receptacle connectors mate CMD***PM****H plug connectors, (see pages 8 to 16), when both of them, (receptacle and plug), are equipped with the same contact positions number, appropriate hardware, and identical polarizing combination.
7. Weights of these connectors are specified in the table II of the previous page.
8. Connectors for measuring and test devices, (i.e. extender board applications), are indicated on pages 53 to 58.

▶ HOW TO ORDER



1 ▶ CONNECTOR FAMILY

2 ▶ CONNECTOR SIZE

CHECK FIRM 42 CONTACT POSITIONS
CHECK FIRM 126 CONTACT POSITIONS

CHECK FIRM 82 CONTACT POSITIONS
1 5 8 158 CONTACT POSITIONS

1 1 0 110 CONTACT POSITIONS
1 7 4 174 CONTACT POSITIONS

3 ▶ CONNECTOR STYLE

E RECEPTACLE CONNECTOR

4 ▶ CONTACT STYLE

F SOCKET CONTACT

5 ▶ CONTACT TERMINAL STYLE *Flex circuit for straddle mount, with board package thickness:*

N FROM .039 TO .079 INCH (FROM 1.00 TO 2.00 MM)

R FROM .067 TO .106 INCH (FROM 1.70 TO 2.70 MM)

T FROM .106 TO .146 INCH (FROM 2.70 TO 3.70 MM)

V FROM .126 TO .165 INCH (FROM 3.20 TO 4.20 MM)

6 ▶ HARDWARE CODE

Y D-SHAPED GUIDE SOCKETS

P UNIVERSAL COUPLING GUIDE SOCKETS (*for test type connectors*)

7 ▶ HARDWARE POLARIZATION

0 0 WHEN D-SHAPED GUIDE SOCKETS ARE INSTALLED IN THE 01 POLARIZED POSITION, (*see polarization configurations chart on page 44*), WITHOUT LOCTITE 242 APPLIED.

0 1 TO **3 6** WHEN D-SHAPED GUIDE SOCKETS ARE INSTALLED IN THE PROPER POLARIZED POSITION AND LOCTITE 242 IS APPLIED TO THE THREADS, (*see polarization configuration chart on page 44*).

3 7 WHEN UNIVERSAL COUPLING GUIDE SOCKETS, (*for test type connectors*), ARE INSTALLED.

3 8 WHEN D-SHAPED GUIDE SOCKETS OR UNIVERSAL COUPLING GUIDE SOCKETS (*for test type connectors*), ARE SHIPPED LOOSE IN A PLASTIC BAG.

8 ▶ CONTACT FINISHING

H CONTACTS WITH PLATING AND UNDERPLATING CONFORMING TO MIL-C-55302

▶ **RECEPTACLE CONNECTOR:
42, 82, 110, 126, 158 AND 174 SOCKET CONTACT POSITIONS**

**RECEPTACLE CONNECTOR: 42, 82, 110, 126, 158 AND 174 SOCKET CONTACT POSITIONS,
.075 INCH SPACING (1.905 MM), DIP SOLDER (RIGHT ANGLE) TERMINAL STYLE**

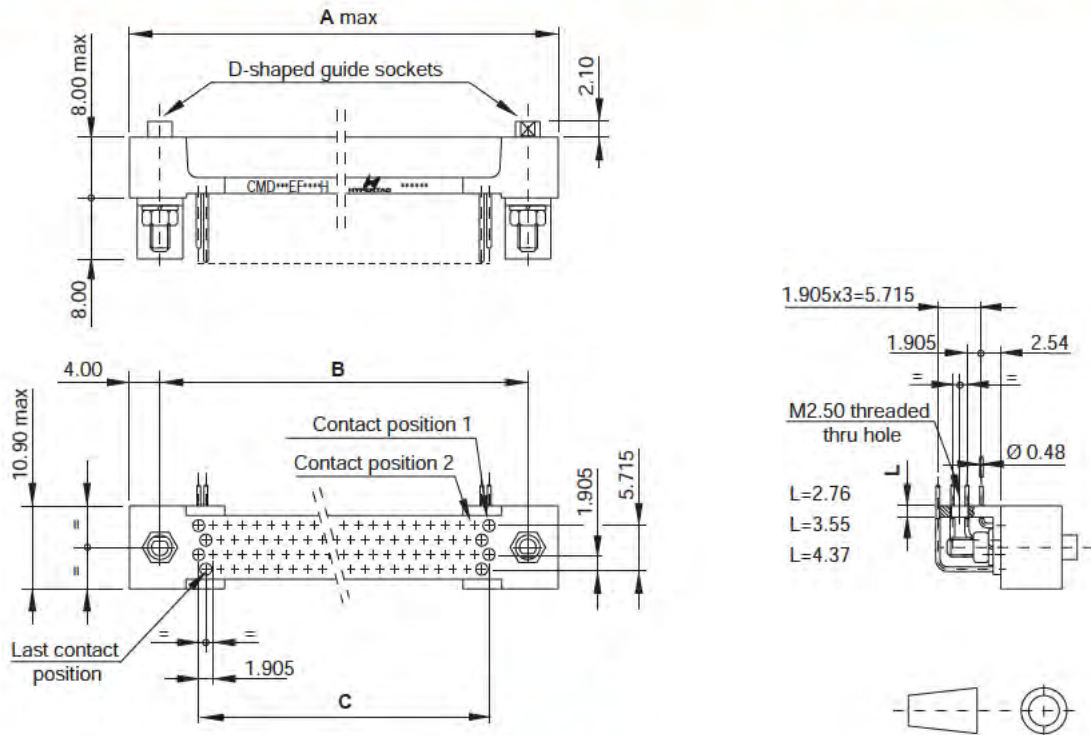

Figure 15

**MOUNTING PATTERN, EXTENDER BOARD AND IN LINE BOARD-TO-BOARD APPLICATIONS,
(RECOMMENDED PCB HOLE CONFIGURATION)**

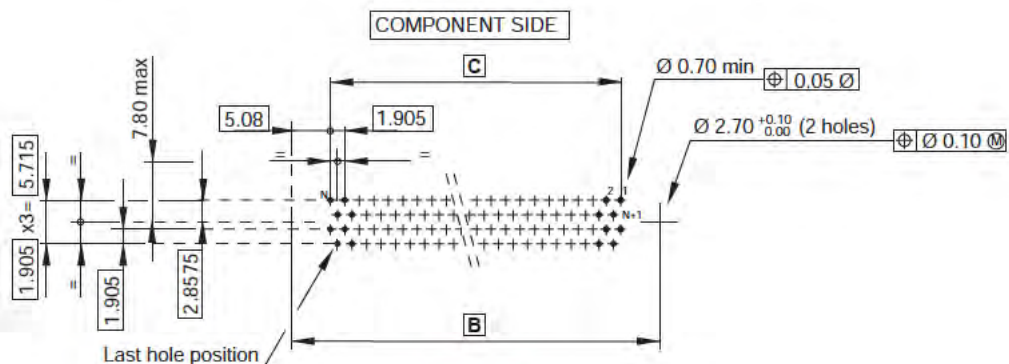

Figure 16

► **RECEPTACLE CONNECTOR:
42, 82, 110, 126, 158 AND 174 SOCKET CONTACT POSITIONS**

TABLE I

| Dimensions in width | | | | |
|---------------------|---------|--------|--------|--------|
| Contact positions | A (mm) | B (mm) | C (mm) | D (mm) |
| 42 | 37.210 | 29.210 | 19.050 | 22.50 |
| 82 | 56.260 | 48.260 | 38.100 | 41.60 |
| 110 | 69.595 | 61.595 | 51.435 | 54.90 |
| 126 | 77.215 | 69.215 | 59.055 | 62.50 |
| 158 | 92.455 | 84.455 | 74.295 | 77.90 |
| 174 | 100.075 | 92.075 | 81.915 | 85.40 |

TABLE II

| Contact positions | Weight* in grams (with g=9.81 m/s ²) | | * According to contacts terminal length and with D-shaped guide sockets installed |
|-------------------|---|------|---|
| | from | to | |
| 42 | 10.0 | 11.0 | |
| 82 | 14.0 | 15.0 | |
| 110 | 17.0 | 18.0 | |
| 126 | 19.0 | 20.0 | |
| 158 | 23.0 | 24.5 | |
| 174 | 24.0 | 25.5 | |

NOTES

1. Dimensions for user installation purpose only.
2. Dimensions are in millimeters.
3. Dimensions in width of these connectors are specified in the table I of this page.
4. Materials, finishes and connectors requirements are described into this catalog. Hot solder dipping, as dip solder terminal end finishing, is available at Customer request, (please consult the Factory).
5. These receptacle connectors are conforming to MIL-C-55302.
6. These receptacle connectors mate CMD***PM***H plug connectors, (see pages 8 to 16), when both of them, (receptacle and plug), are equipped with the same contact positions number, appropriate hardware, and identical polarizing combination.
7. Weights of these connectors are specified in the table II of this page.
8. Connectors for measuring and test devices, (i.e. extender board applications), are indicated on pages 53 to 58.

▶ HOW TO ORDER



1 ▶ CONNECTOR FAMILY

2 ▶ CONNECTOR SIZE

0 4 2 42 CONTACT POSITIONS

0 8 2 82 CONTACT POSITIONS

1 1 0 110 CONTACT POSITIONS

1 2 6 126 CONTACT POSITIONS

1 5 8 158 CONTACT POSITIONS

1 7 4 174 CONTACT POSITIONS

3 ▶ CONNECTOR STYLE

E RECEPTACLE CONNECTOR

4 ▶ CONTACT STYLE

F SOCKET CONTACT

5 ▶ CONTACT TERMINAL STYLE *Dip solder, right angle, with:*

A .109 INCH (2.76 MM) LONG DIP

B .140 INCH (3.55 MM) LONG DIP

C .172 INCH (4.37 MM) LONG DIP

6 ▶ HARDWARE CODE

Y D-SHAPED GUIDE SOCKETS

P UNIVERSAL COUPLING GUIDE SOCKETS (*for test type connectors*)

7 ▶ HARDWARE POLARIZATION

0 0 WHEN D-SHAPED GUIDE SOCKETS ARE INSTALLED IN THE 01 POLARIZED POSITION, (*see polarization configurations chart on page 44*), WITHOUT LOCTITE 242 APPLIED.

0 1 TO **3 6** WHEN D-SHAPED GUIDE SOCKETS ARE INSTALLED IN THE PROPER POLARIZED POSITION AND LOCTITE 242 IS APPLIED TO THE THREADS, (*see polarization configuration chart on page 44*).

3 7 WHEN UNIVERSAL COUPLING GUIDE SOCKETS, (*for test type connectors*), ARE INSTALLED.

3 8 WHEN D-SHAPED GUIDE SOCKETS OR UNIVERSAL COUPLING GUIDE SOCKETS, (*for test type connectors*), ARE SHIPPED LOOSE IN A PLASTIC BAG.

8 ▶ CONTACT FINISHING

H CONTACTS WITH PLATING AND UNDERPLATING CONFORMING TO MIL-C-55302

► **PLUG CONNECTOR:
220, 236 AND 316 PIN CONTACT POSITIONS**

**PLUG CONNECTOR: 220, 236 AND 316 PIN CONTACT POSITIONS,
.075 INCH SPACING (1.905 MM), DIP SOLDER (RIGHT ANGLE) TERMINAL STYLE**

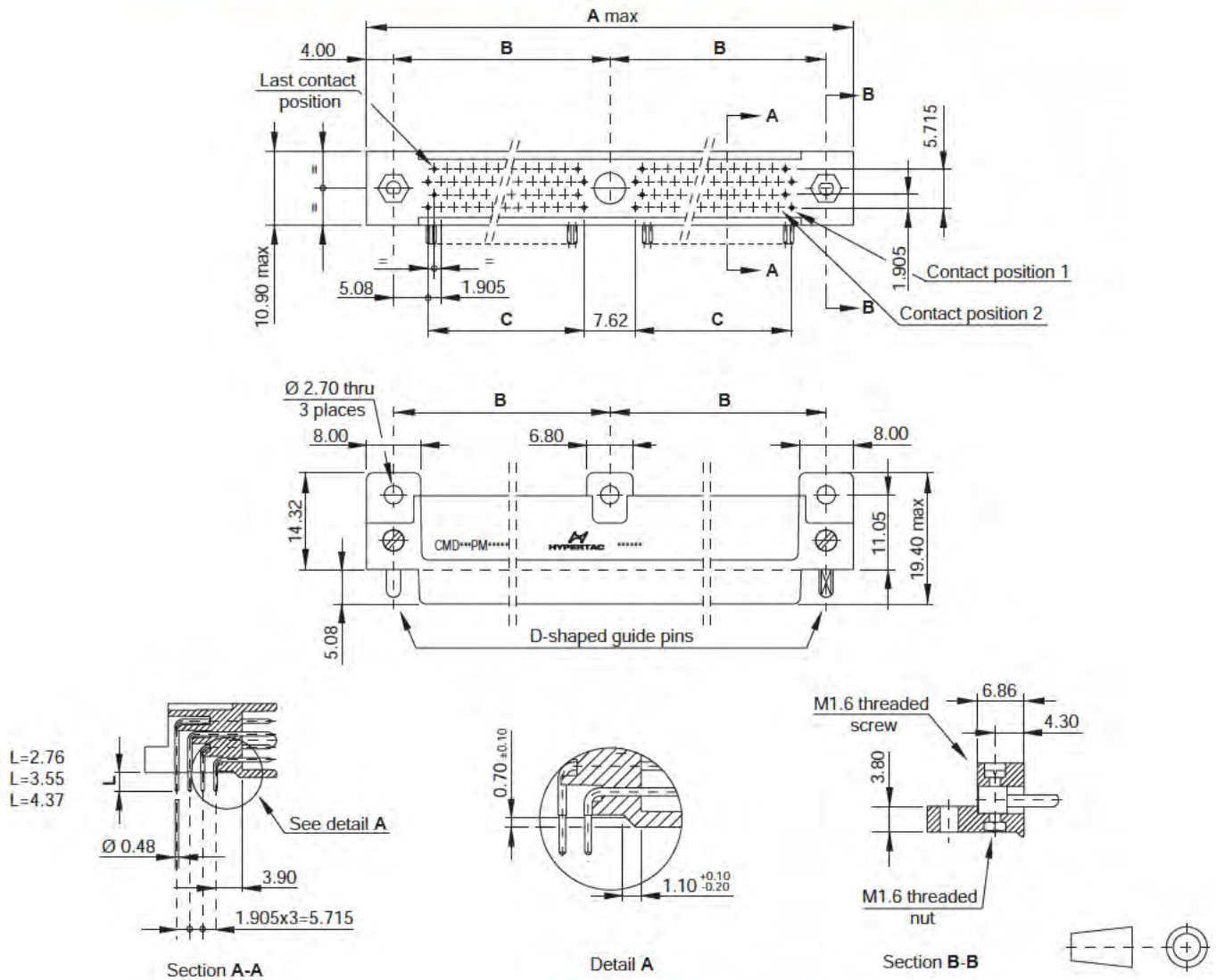

Figure 17

**MOUNTING PATTERN, DAUGHTERBOARD APPLICATION,
(RECOMMENDED PCB HOLE CONFIGURATION)**

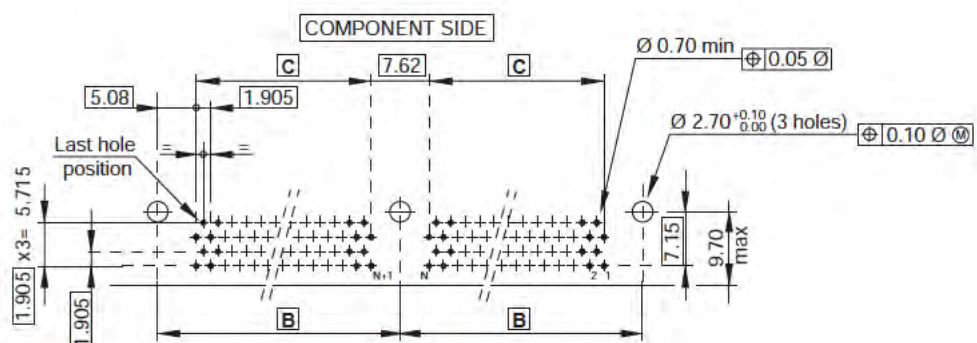

Figure 18

► **PLUG CONNECTOR:
220, 236 AND 316 PIN CONTACT POSITIONS**

TABLE I

| Dimensions in width | | | |
|---------------------|---------|--------|--------|
| Contact positions | A (mm) | B (mm) | C (mm) |
| 220 | 128.650 | 60.325 | 51.435 |
| 236 | 136.270 | 64.135 | 55.245 |
| 316 | 174.370 | 83.185 | 74.295 |

TABLE II

| Contact positions | Weight* in grams (with $g=9.81 \text{ m/s}^2$) | | * According to contacts terminal length and with D-shaped guide pins installed |
|-------------------|--|------|--|
| | from | to | |
| 220 | 25.0 | 26.0 | |
| 236 | 26.5 | 28.0 | |
| 316 | 33.5 | 36.0 | |

NOTES

1. Dimensions for user installation purpose only.
2. Dimensions are in millimeters.
3. Dimensions in width of these connectors are specified in the table I of this page.
4. Materials, finishes and connectors requirements are described into this catalog. Hot solder dipping, as dip solder terminal end finishing, is available at Customer request, (please consult the Factory).
5. These plug connectors are conforming to MIL-C-55302.
6. These plug connectors mate CMD***EF****H receptacle connectors, (see pages 35 to 43), when both of them, (plug and receptacle), are equipped with the same contact positions number, appropriate hardware, and identical polarizing combination.
7. Weights of these connectors are specified in the table II of this page.
8. Connectors for measuring and test devices, (i.e. extender board applications), are indicated on pages 53 to 58.

▶ HOW TO ORDER



1 ▶ CONNECTOR FAMILY

2 ▶ CONNECTOR SIZE

2 2 0 220 CONTACT POSITIONS

2 3 6 236 CONTACT POSITIONS

3 1 6 316 CONTACT POSITIONS

3 ▶ CONNECTOR STYLE

P PLUG CONNECTOR

4 ▶ CONTACT STYLE

M PIN CONTACT

5 ▶ CONTACT TERMINAL STYLE *Dip solder, right angle, with:*

A .109 INCH (2.76 MM) LONG DIP

B .140 INCH (3.55 MM) LONG DIP

C .172 INCH (4.37 MM) LONG DIP

6 ▶ HARDWARE CODE

Y D-SHAPED GUIDE PINS

P UNIVERSAL COUPLING GUIDE PINS (*for test type connectors*)

7 ▶ HARDWARE POLARIZATION

0 0 WHEN D-SHAPED GUIDE PINS ARE INSTALLED IN THE 01 POLARIZED POSITION, (*see polarization configurations chart on page 44*), WITHOUT LOCTITE 242 APPLIED.

0 1 TO **3 6** WHEN D-SHAPED GUIDE PINS ARE INSTALLED IN THE PROPER POLARIZED POSITION AND LOCTITE 242 IS APPLIED TO THE THREADS, (*see polarization configuration chart on page 44*).

3 7 WHEN UNIVERSAL COUPLING GUIDE PINS, (*for test type connectors*), ARE INSTALLED.

3 8 WHEN D-SHAPED GUIDE PINS OR UNIVERSAL COUPLING GUIDE PINS, (*for test type connectors*), ARE SHIPPED LOOSE IN A PLASTIC BAG.

8 ▶ CONTACT FINISHING

H CONTACTS WITH PLATING AND UNDERPLATING CONFORMING TO MIL-C-55302

► **PLUG CONNECTOR:
220, 236 AND 316 PIN CONTACT POSITIONS**

**PLUG CONNECTOR: 220, 236 AND 316 PIN CONTACT POSITIONS,
.075 INCH SPACING (1.905 MM), DIP SOLDER (STRAIGHT) TERMINAL STYLE**

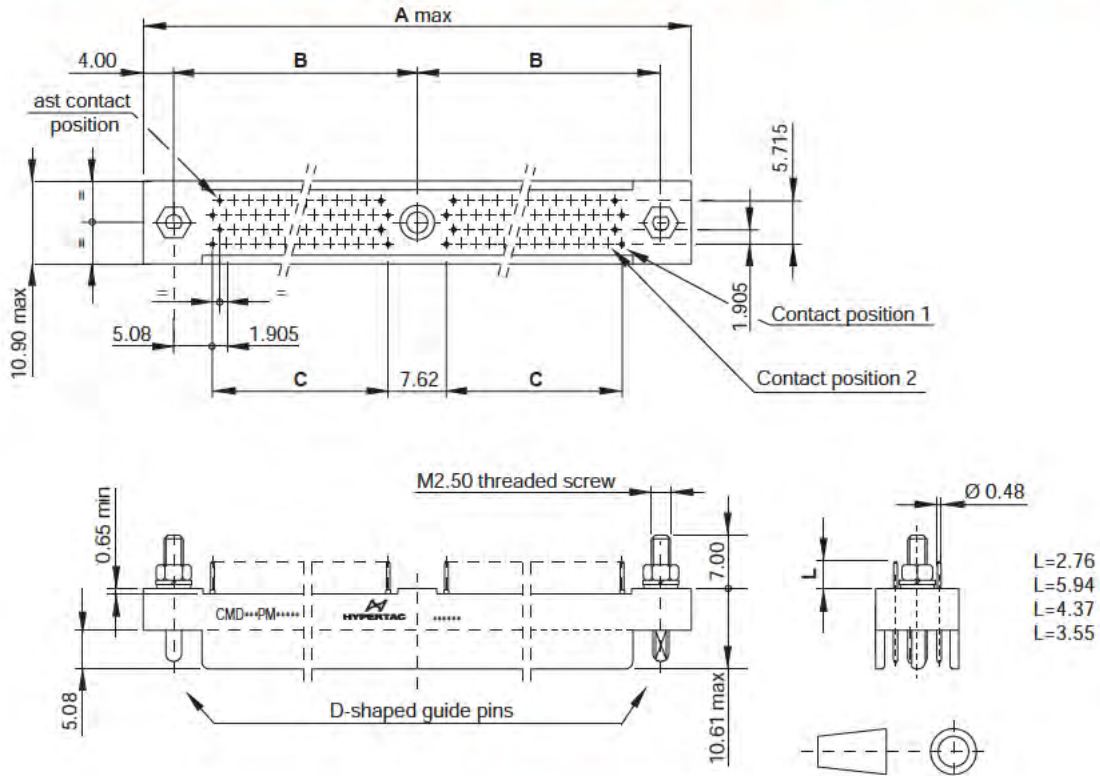

Figure 19

**MOUNTING PATTERN, IN PARALLEL ARRANGEMENT BOARD-TO-BOARD CONNECTION,
(RECOMMENDED PCB HOLE CONFIGURATION)**

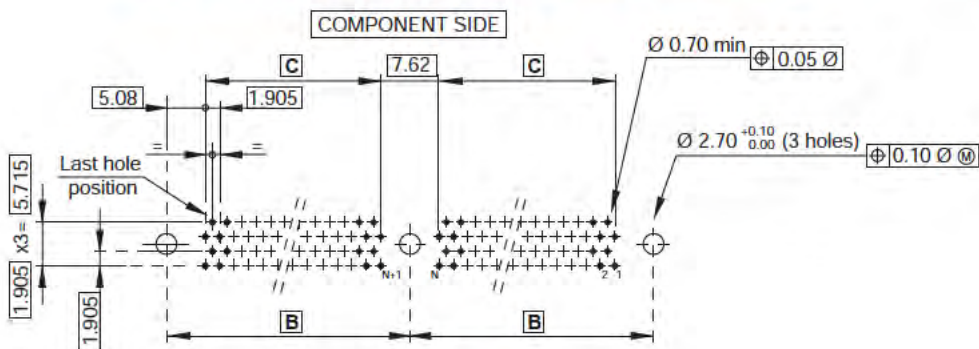

Figure 20

► **PLUG CONNECTOR:
220, 236 AND 316 PIN CONTACT POSITIONS**

TABLE I

| Dimensions in width | | | |
|---------------------|---------|--------|--------|
| Contact positions | A (mm) | B (mm) | C (mm) |
| 220 | 128.650 | 60.325 | 51.435 |
| 236 | 136.270 | 64.135 | 55.245 |
| 316 | 174.370 | 83.185 | 74.295 |

TABLE II

| Contact positions | Weight* in grams (with $g=9.81 \text{ m/s}^2$) | | * According to contacts terminal length and with D-shaped guide pins installed |
|-------------------|--|------|--|
| | from | to | |
| 220 | 17.5 | 18.5 | |
| 236 | 18.5 | 19.5 | |
| 316 | 23.5 | 24.5 | |

NOTES

1. Dimensions for User installation purpose only.
2. Dimensions are in millimeters.
3. Dimensions in width of these connectors are specified in the table I of this page.
4. Materials, finishes and connectors requirements are described into this catalog. Hot solder dipping, as dip solder terminal end finishing, is available at Customer request, (please consult the Factory).
5. These plug connectors are conforming to MIL-C-55302.
6. These plug connectors mate CMD***EF****H receptacle connectors, (see pages 35 to 43), when both of them, (plug and receptacle), are equipped with the same contact positions number, appropriate hardware, and identical polarizing combination.
7. Weights of these connectors are specified in the table II of this page.
8. Connectors for measuring and test devices, (i.e. extender board applications), are indicated on pages 53 to 58.

▶ HOW TO ORDER



1 ▶ CONNECTOR FAMILY

2 ▶ CONNECTOR SIZE

CHECK FIRM 220 CONTACT POSITIONS **CHECK FIRM** 236 CONTACT POSITIONS
CHECK FIRM 316 CONTACT POSITIONS

3 ▶ CONNECTOR STYLE

P PLUG CONNECTOR

4 ▶ CONTACT STYLE

M PIN CONTACT

5 ▶ CONTACT TERMINAL STYLE *Dip solder, straight thru, with:*

D .109 INCH (2.76 MM) LONG DIP **E** .140 INCH (3.55 MM) LONG DIP
G .172 INCH (4.37 MM) LONG DIP **L** .234 INCH (5.94 MM) LONG DIP

6 ▶ HARDWARE CODE

Y D-SHAPED GUIDE PINS **P** UNIVERSAL COUPLING GUIDE PINS *(for test type connectors)*

7 ▶ HARDWARE POLARIZATION

01 TO **36** WHEN D-SHAPED GUIDE PINS ARE INSTALLED IN THE PROPER POLARIZED POSITION,
(see polarization configuration chart on page 44).

37 WHEN UNIVERSAL COUPLING GUIDE PINS, *(for test type connectors)*, ARE INSTALLED.

38 WHEN D-SHAPED GUIDE PINS OR UNIVERSAL COUPLING GUIDE PINS, *(for test type connectors)*, ARE SHIPPED
 LOOSE IN A PLASTIC BAG.

8 ▶ CONTACT FINISHING

H CONTACTS WITH PLATING AND UNDERPLATING CONFORMING TO MIL-C-55302

► **PLUG CONNECTOR:
220, 236 AND 316 PIN CONTACT POSITIONS**

**PLUG CONNECTOR: 220, 236 AND 316 PIN CONTACT POSITIONS,
.075 INCH SPACING (1.905 MM), BOARD PACKAGE THICKNESS FROM 1.00 TO 4.20 MM**

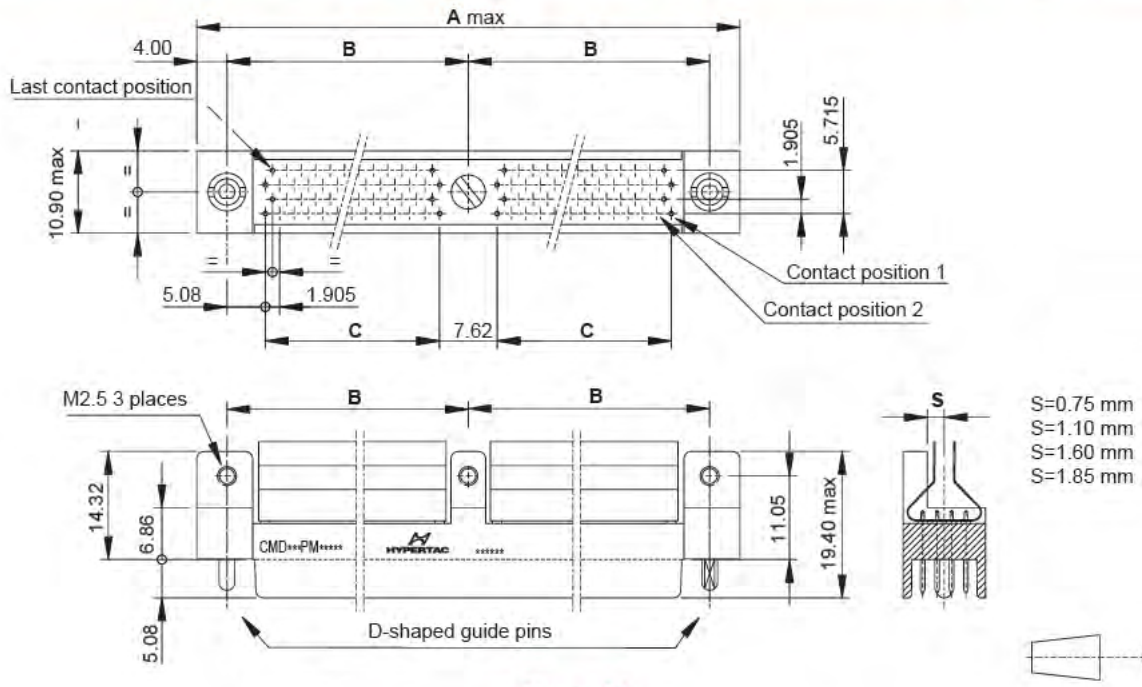

Figure 21

CONTACT PATTERN NUMBERING

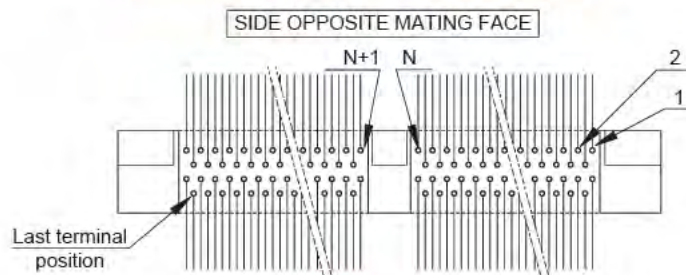

Figure 22

TABLE I

| Dimensions in width | | | |
|---------------------|---------|--------|--------|
| Contact positions | A (mm) | B (mm) | C (mm) |
| 220 | 128.650 | 60.325 | 51.435 |
| 236 | 136.270 | 64.135 | 55.245 |
| 316 | 174.370 | 83.185 | 74.295 |

TABLE II

| Contact positions | Weight* in grams (with g=9.81 m/s ²) | | * According to variations of soldering and insulating compound weight, and with D-shaped guide pins installed |
|-------------------|---|------|---|
| | from | to | |
| 220 | 25.5 | 26.5 | |
| 236 | 27.0 | 28.0 | |
| 316 | 35.0 | 36.0 | |

► **PLUG CONNECTOR:
220, 236 AND 316 PIN CONTACT POSITIONS**

MOUNTING PATTERN, DAUGHTERBOARD APPLICATION

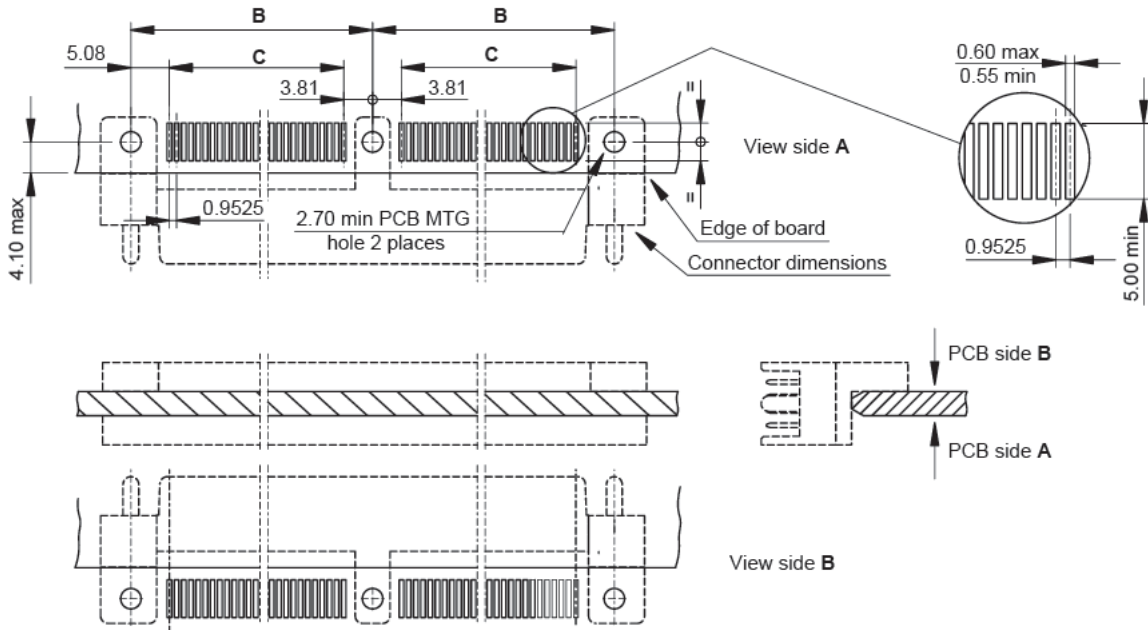

Figure 23

NOTES

1. Dimensions for user installation purpose only.
2. Dimensions are in millimeters.
3. Dimensions in width of these connectors are specified in the table I of the previous page.
4. Materials, finishes and connectors requirements are described into this catalog.
5. These plug connectors are conforming to MIL-C-55302, and their flex circuits, as surface mount tail terminals, are in accordance with MIL-P-50884.
6. These plug connectors mate CMD***EF***H receptacle connectors, (see pages 35 to 43), when both of them, (plug and receptacle), are equipped with the same contact positions number, appropriate hardware, and identical polarizing combination.
7. Weights of these connectors are specified in the table II of the previous page.
8. Connectors for measuring and test devices, (i.e. extender board applications), are indicated on pages 53 to 58.

▶ HOW TO ORDER



1 ▶ CONNECTOR FAMILY

2 ▶ CONNECTOR SIZE

CHECK FIRM 220 CONTACT POSITIONS **2 3 6** 236 CONTACT POSITIONS **3 1 6** 316 CONTACT POSITIONS

3 ▶ CONNECTOR STYLE

P PLUG CONNECTOR

4 ▶ CONTACT STYLE

M PIN CONTACT

5 ▶ CONTACT TERMINAL STYLE *Flex circuit straddle mount, with board package thickness:*

N FROM .039 TO .079 INCH (FROM 1.00 TO 2.00 MM) **R** FROM .067 TO .106 INCH (FROM 1.70 TO 2.70 MM)
T FROM .106 TO .146 INCH (FROM 2.70 TO 3.70 MM) **V** FROM .126 TO .165 INCH (FROM 3.20 TO 4.20 MM)

6 ▶ HARDWARE CODE

Y D-SHAPED GUIDE PINS **P** UNIVERSAL COUPLING GUIDE PINS (*for test type connectors*)

7 ▶ HARDWARE POLARIZATION

- 0 0** WHEN D-SHAPED GUIDE PINS ARE INSTALLED IN THE 01 POLARIZED POSITION, (*see polarization configurations chart on page 44*), WITHOUT LOCTITE 242 APPLIED.
- 0 1** TO **3 6** WHEN D-SHAPED GUIDE PINS ARE INSTALLED IN THE PROPER POLARIZED POSITION AND LOCTITE 242 IS APPLIED TO THE THREADS, (*see polarization configuration chart on page 44*).
- 3 7** WHEN UNIVERSAL COUPLING GUIDE PINS, (*for test type connectors*), ARE INSTALLED.
- 3 8** WHEN D-SHAPED GUIDE PINS OR UNIVERSAL COUPLING GUIDE PINS, (*for test type connectors*), ARE SHIPPED LOOSE IN A PLASTIC BAG.

8 ▶ CONTACT FINISHING

H CONTACTS WITH PLATING AND UNDERPLATING CONFORMING TO MIL-C-55302

RECEPTACLE CONNECTOR:
220, 236 AND 316 SOCKET CONTACT POSITIONS

RECEPTACLE CONNECTOR: 220, 236 AND 316 SOCKET CONTACT POSITIONS,
.075 INCH SPACING (1.905 MM), DIP SOLDER (STRAIGHT) AND WIRE WRAP POST TERMINAL STYLE

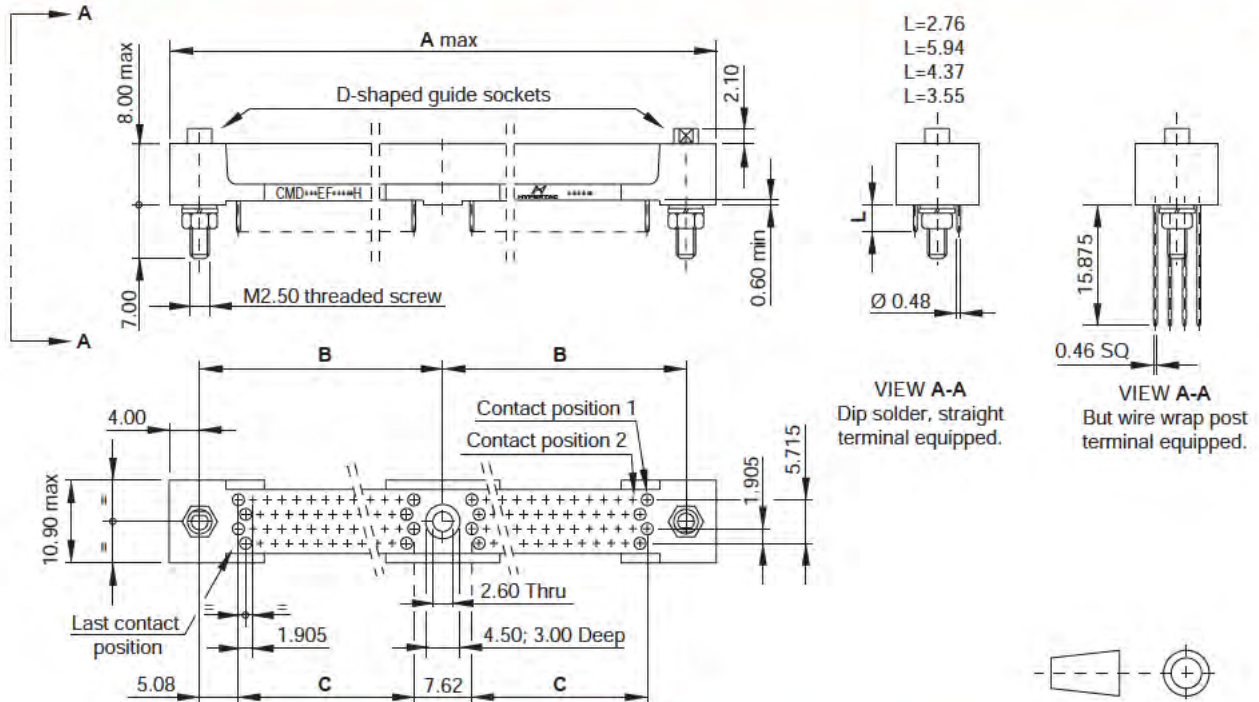

Figure 24

MOUNTING PATTERN, MOTHERBOARD APPLICATION,
(RECOMMENDED PWB HOLE CONFIGURATION)

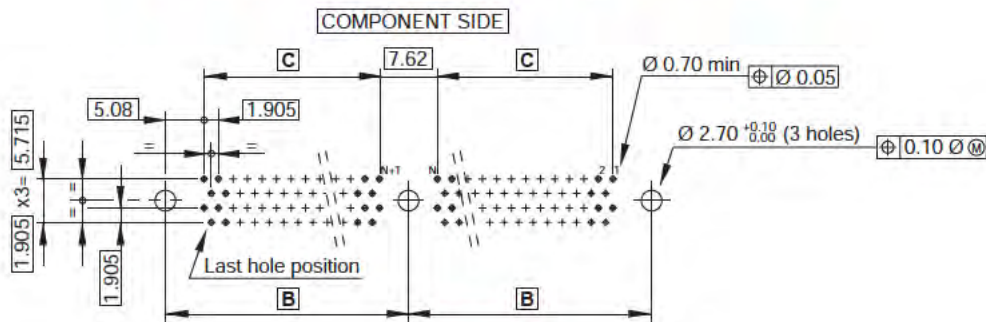

Figure 25

RECOMMENDED PANEL CUT-OUT

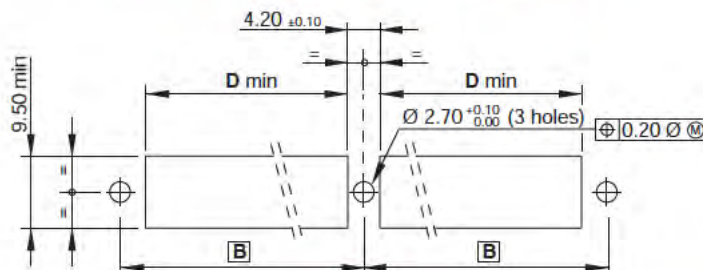

Figure 26

▶ **RECEPTACLE CONNECTOR:
220, 236 AND 316 SOCKET CONTACT POSITIONS**

TABLE I

| Dimensions in width | | | | |
|---------------------|---------|--------|--------|--------|
| Contact positions | A (mm) | B (mm) | C (mm) | D (mm) |
| 220 | 128.650 | 60.325 | 51.435 | 54.90 |
| 236 | 136.270 | 64.135 | 55.245 | 58.70 |
| 316 | 174.370 | 83.185 | 74.295 | 77.70 |

TABLE II

| Contact positions | Weight* in grams (with $g=9.81 \text{ m/s}^2$) | | * According to contacts terminal length (straight type), and with D-shaped guide sockets installed |
|-------------------|--|------|--|
| | from | to | |
| 220 | 24.0 | 26.0 | |
| 236 | 25.5 | 27.5 | |
| 316 | 33.5 | 36.0 | |

NOTES

1. Dimensions for user installation purpose only.
2. Dimensions are in millimeters.
3. Dimensions in width of these connectors are specified in the table I of this page.
4. Materials, finishes and connectors requirements are described into this catalog. Hot solder dipping, as dip solder terminal end finishing, is available at Customer request, (please consult the Factory).
5. These receptacle connectors are conforming to MIL-C-55302.
6. These receptacle connectors mate CMD***PM****H plug connectors, (see pages 26 to 34), when both of them, (receptacle and plug), are equipped with the same contact positions number, appropriate hardware, and identical polarizing combination.
7. Weights of these connectors are specified in the table II of this page.
8. Connectors for measuring and test devices, (i.e. extender board applications), are indicated on pages 53 to 58.

▶ HOW TO ORDER



1 ▶ CONNECTOR FAMILY

2 ▶ CONNECTOR SIZE

2 2 0 220 CONTACT POSITIONS

2 3 6 236 CONTACT POSITIONS

3 1 6 316 CONTACT POSITIONS

3 ▶ CONNECTOR STYLE

E RECEPTACLE CONNECTOR

4 ▶ CONTACT STYLE

F SOCKET CONTACT

5 ▶ CONTACT TERMINAL STYLE *Dip solder, straight thru, with:*

D .109 INCH (2.76 MM) LONG DIP

E .140 INCH (3.55 MM) LONG DIP

G .172 INCH (4.37 MM) LONG DIP

L .234 INCH (5.94 MM) LONG DIP

Wire wrap with:

Y .625 INCH (15.875 MM) LONG POST

6 ▶ HARDWARE CODE

Y D-SHAPED GUIDE SOCKET

P UNIVERSAL COUPLING GUIDE SOCKET (*for test type connectors*)

7 ▶ HARDWARE POLARIZATION

0 1 TO **3 6** WHEN D-SHAPED GUIDE SOCKETS ARE INSTALLED IN THE PROPER POLARIZED POSITION (*see polarization configuration chart on page 44*).

3 7 WHEN UNIVERSAL COUPLING GUIDE SOCKETS, (*for test type connectors*), ARE INSTALLED.

3 8 WHEN D-SHAPED GUIDE SOCKETS OR UNIVERSAL COUPLING GUIDE SOCKETS (*for test type connectors*), ARE SHIPPED LOOSE IN A PLASTIC BAG.

8 ▶ CONTACT FINISHING

H CONTACTS WITH PLATING AND UNDERPLATING CONFORMING TO MIL-C-55302

RECEPTACLE CONNECTOR:
220, 236 AND 316 SOCKET CONTACT POSITIONS

RECEPTACLE CONNECTOR: 220, 236 AND 316 SOCKET CONTACT POSITIONS,
.075 INCH SPACING (1.905 MM), BOARD PACKAGE THICKNESS FROM 1.00 TO 4.20 MM

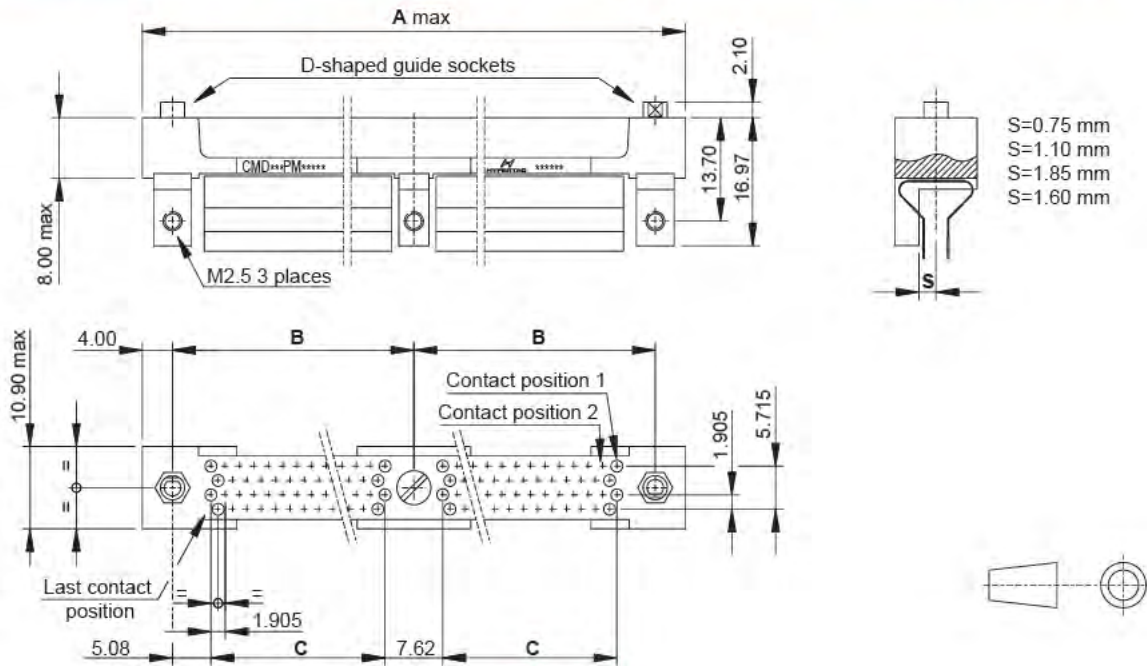

Figure 27

CONTACT PATTERN NUMBERING

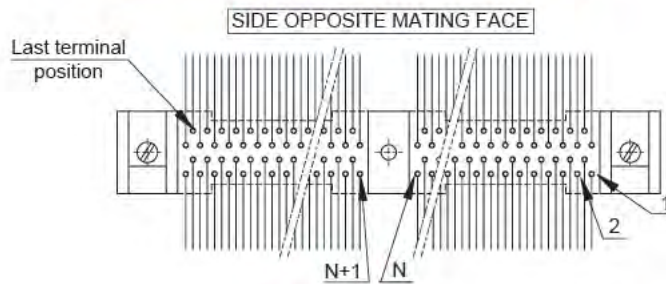

Figure 28

TABLE I

| Dimensions in width | | | |
|---------------------|---------|--------|--------|
| Contact positions | A (mm) | B (mm) | C (mm) |
| 220 | 128.650 | 60.325 | 51.435 |
| 236 | 136.270 | 64.135 | 55.245 |
| 316 | 174.370 | 83.185 | 74.295 |

TABLE II

| Contact positions | Weight* in grams (with $g=9.81 \text{ m/s}^2$) | | * According to variations of soldering and insulating compound weight, and with D-shaped guide sockets installed |
|-------------------|--|------|--|
| | from | to | |
| 220 | 30.5 | 31.5 | |
| 236 | 32.0 | 33.0 | |
| 316 | 40.5 | 41.5 | |

► **RECEPTACLE CONNECTOR:
220, 236 AND 316 SOCKET CONTACT POSITIONS**

MOUNTING PATTERN, DAUGHTERBOARD APPLICATION

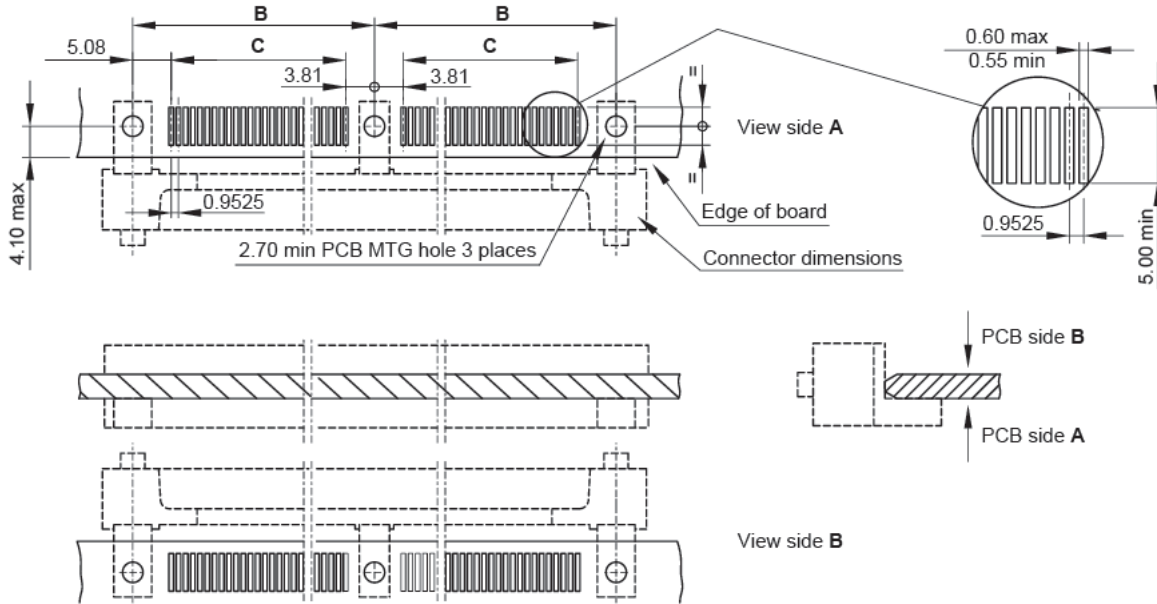

Figure 29

NOTES

1. Dimensions for user installation purpose only .
2. Dimensions are in millimeters.
3. Dimensions in width of these connectors are specified in the table I of the previous page.
4. Materials, finishes and connectors requirements are described into this catalog.
5. These receptacle connectors are conforming to MIL-C-55302, and their flex-circuits, as surface mount tail terminals, are in accordance with MIL-P-50884.
6. These receptacle connectors mate CMD***PM****H plug connectors, (see pages 26 to 34), when both of them, (receptacle and plug), are equipped with the same contact positions number, appropriate hardware, and identical polarizing combination.
7. Weights of these connectors are specified in the table II of the previous page.
8. Connectors for measuring and test devices, (i.e. extender board applications), are indicated on pages 53 to 58.

▶ HOW TO ORDER



1 ▶ CONNECTOR FAMILY

2 ▶ CONNECTOR SIZE

CHECK FIRM 220 CONTACT POSITIONS

2 3 6 236 CONTACT POSITIONS

3 1 6 316 CONTACT POSITIONS

3 ▶ CONNECTOR STYLE

E RECEPTACLE CONNECTOR

4 ▶ CONTACT STYLE

F SOCKET CONTACT

5 ▶ CONTACT TERMINAL STYLE *Flex circuit for straddle mount, with board package thickness:*

N FROM .004 TO .008 INCH (FROM 1.00 TO 2.00 MM)

R FROM .007 TO .106 INCH (FROM 1.70 TO 2.70 MM)

T FROM .106 TO .146 INCH (FROM 2.70 TO 3.70 MM)

V FROM .126 TO .165 INCH (FROM 3.20 TO 4.20 MM)

6 ▶ HARDWARE CODE

Y D-SHAPED GUIDE PINS

P UNIVERSAL COUPLING GUIDE PINS (*for test type connectors*)

7 ▶ HARDWARE POLARIZATION

0 0 WHEN D-SHAPED GUIDE SOCKETS ARE INSTALLED IN THE 01 POLARIZED POSITION, (*see polarization configurations chart on page 44*), WITHOUT LOCTITE 242 APPLIED.

0 1 TO **3 6** WHEN D-SHAPED GUIDE SOCKETS ARE INSTALLED IN THE PROPER POLARIZED POSITION AND LOCTITE 242 IS APPLIED TO THE THREADS, (*see polarization configuration chart on page 44*).

3 7 WHEN UNIVERSAL COUPLING GUIDE SOCKETS, (*for test type connectors*), ARE INSTALLED.

3 8 WHEN D-SHAPED GUIDE SOCKETS OR UNIVERSAL COUPLING GUIDE SOCKETS (*for test type connectors*), ARE SHIPPED LOOSE IN A PLASTIC BAG.

8 ▶ CONTACT FINISHING

H CONTACTS WITH PLATING AND UNDERPLATING CONFORMING TO MIL-C-55302

RECEPTACLE CONNECTOR:
220, 236 AND 316 SOCKET CONTACT POSITIONS

RECEPTACLE CONNECTOR: 220, 236 AND 316 SOCKET CONTACT POSITIONS,
.075 INCH SPACING (1.905 MM), DIP SOLDER (RIGHT ANGLE) TERMINAL STYLE

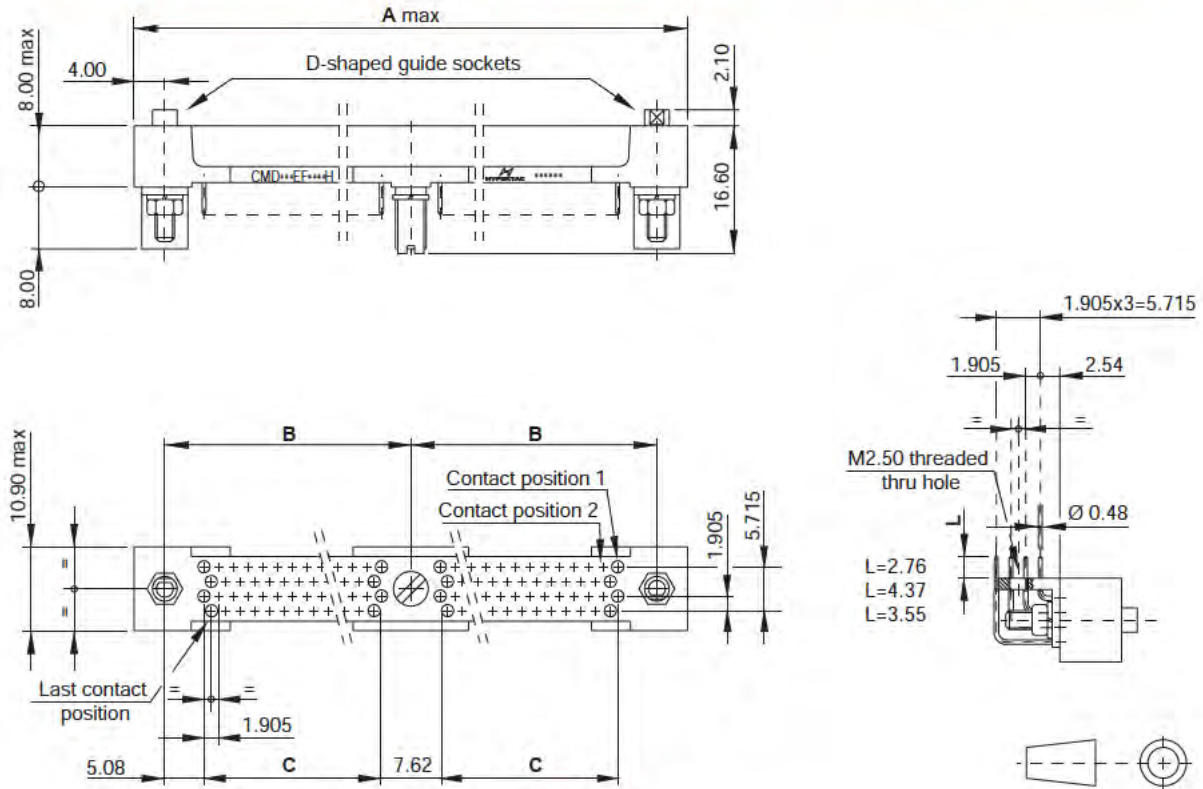

Figure 30

MOUNTING PATTERN, EXTENDER BOARD AND INLINE BOARD-TO-BOARD APPLICATIONS,
(RECOMMENDED PCB HOLE CONFIGURATION)

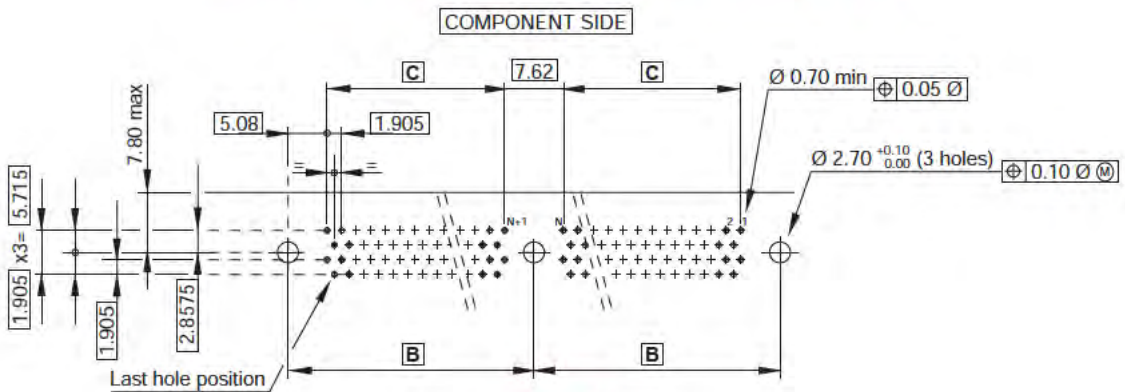

Figure 31

► **RECEPTACLE CONNECTOR:
220, 236 AND 316 SOCKET CONTACT POSITIONS**

TABLE I

| Dimensions in width | | | |
|---------------------|---------|--------|--------|
| Contact position | A (mm) | B (mm) | C (mm) |
| 220 | 128.650 | 60.325 | 51.435 |
| 236 | 136.270 | 64.135 | 55.245 |
| 316 | 174.370 | 83.185 | 74.295 |

TABLE II

| Contact position | Weight* in grams (with g=9.81 m/s ²) | | * According to contacts terminal length, and with D-shaped guide sockets installed |
|------------------|---|------|--|
| | from | to | |
| 220 | 31.5 | 33.0 | |
| 236 | 33.5 | 35.0 | |
| 316 | 42.0 | 44.0 | |

NOTES

1. Dimensions for user installation purpose only.
2. Dimensions are in millimeters.
3. Dimensions in width of these connectors are specified in the table I of this page.
4. Materials, finishes and connectors requirements are described into this catalog. Hot solder dipping, as dip solder terminal end finishing, is available at Customer request, (please consult the Factory).
5. These receptacle connectors are conforming to MIL-C-55302.
6. These receptacle connectors mate CMD***PM****H plug connectors, (see pages 26 to 34), when both of them, (receptacle and plug), are equipped with the same contact positions number, appropriate hardware, and identical polarizing combination.
7. Weights of these connectors are specified in the table II of this page.
8. Connectors for measuring and test devices, (i.e. extender board applications), are indicated on pages 53 to 58.

▶ HOW TO ORDER



1 ▶ CONNECTOR FAMILY

2 ▶ CONNECTOR SIZE

2 2 0 220 CONTACT POSITIONS **2 3 6** 236 CONTACT POSITIONS **3 1 6** 316 CONTACT POSITIONS

3 ▶ CONNECTOR STYLE

E RECEPTACLE CONNECTOR

4 ▶ CONTACT STYLE

F SOCKET CONTACT

5 ▶ CONTACT TERMINAL STYLE *Dip solder, right angle, with:*

A .109 INCH (2.76 MM) LONG DIP **B** .140 INCH (3.55 MM) LONG DIP **C** .172 INCH (4.37 MM) LONG DIP

6 ▶ HARDWARE CODE

Y D-SHAPED GUIDE SOCKET **P** UNIVERSAL COUPLING GUIDE SOCKET (*for test type connectors*)

7 ▶ HARDWARE POLARIZATION

0 0 WHEN D-SHAPED GUIDE SOCKETS ARE INSTALLED IN THE 01 POLARIZED POSITION, (*see polarization configurations chart on page 44*), WITHOUT LOCTITE 242 APPLIED.

0 1 TO **3 6** WHEN D-SHAPED GUIDE SOCKETS ARE INSTALLED IN THE PROPER POLARIZED POSITION AND LOCTITE 242 IS APPLIED TO THE THREADS, (*see polarization configuration chart on page 44*).

3 7 WHEN UNIVERSAL COUPLING GUIDE SOCKETS, (*for test type connectors*), ARE INSTALLED.

3 8 WHEN D-SHAPED GUIDE SOCKETS OR UNIVERSAL COUPLING GUIDE SOCKETS (*for test type connectors*), ARE SHIPPED LOOSE IN A PLASTIC BAG.

8 ▶ CONTACT FINISHING

H CONTACTS WITH PLATING AND UNDERPLATING CONFORMING TO MIL-C-55302

► POLARIZATION CONFIGURATION CHART

D-SHAPED GUIDE SETS

When connector is equipped with D-shaped guide hardware, any of the following polarization numbers are used, polarizing hardware will be oriented per this chart. Use appropriate number as shown, (designation 01 to 36 incl).

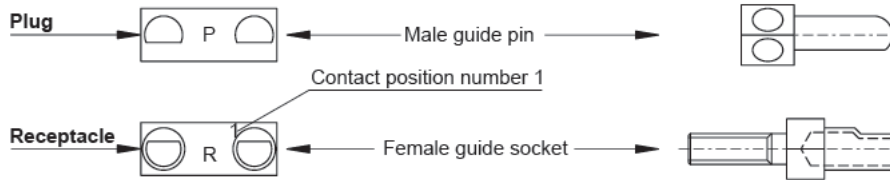

| | | | | | | | | | | | |
|----|--|----|--|----|--|----|--|----|--|----|--|
| 01 | | 07 | | 13 | | 19 | | 25 | | 31 | |
| 02 | | 08 | | 14 | | 20 | | 26 | | 32 | |
| 03 | | 09 | | 15 | | 21 | | 27 | | 33 | |
| 04 | | 10 | | 16 | | 22 | | 28 | | 34 | |
| 05 | | 11 | | 17 | | 23 | | 29 | | 35 | |
| 06 | | 12 | | 18 | | 24 | | 30 | | 36 | |

NOTES

1. It is recommended that the following polarization positions be chosen first: 01, 08, 15, 22, 29, and 36.
2. Universal coupling guide sets, (designation 37)

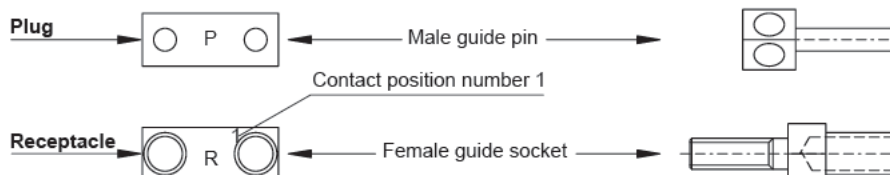

▶ **MAXIMUM DIMENSIONS OF MATED CONNECTORS**

MAXIMUM DIMENSIONS OF MATED CONNECTORS. PLUG CONNECTOR DIP SOLDER (RIGHT ANGLE) TERMINALS SEQUIPPED, AND RECEPTACLE CONNECTOR DIP SOLDER (STRAIGHT), OR WIRE WRAP POST TERMINALS EQUIPPED

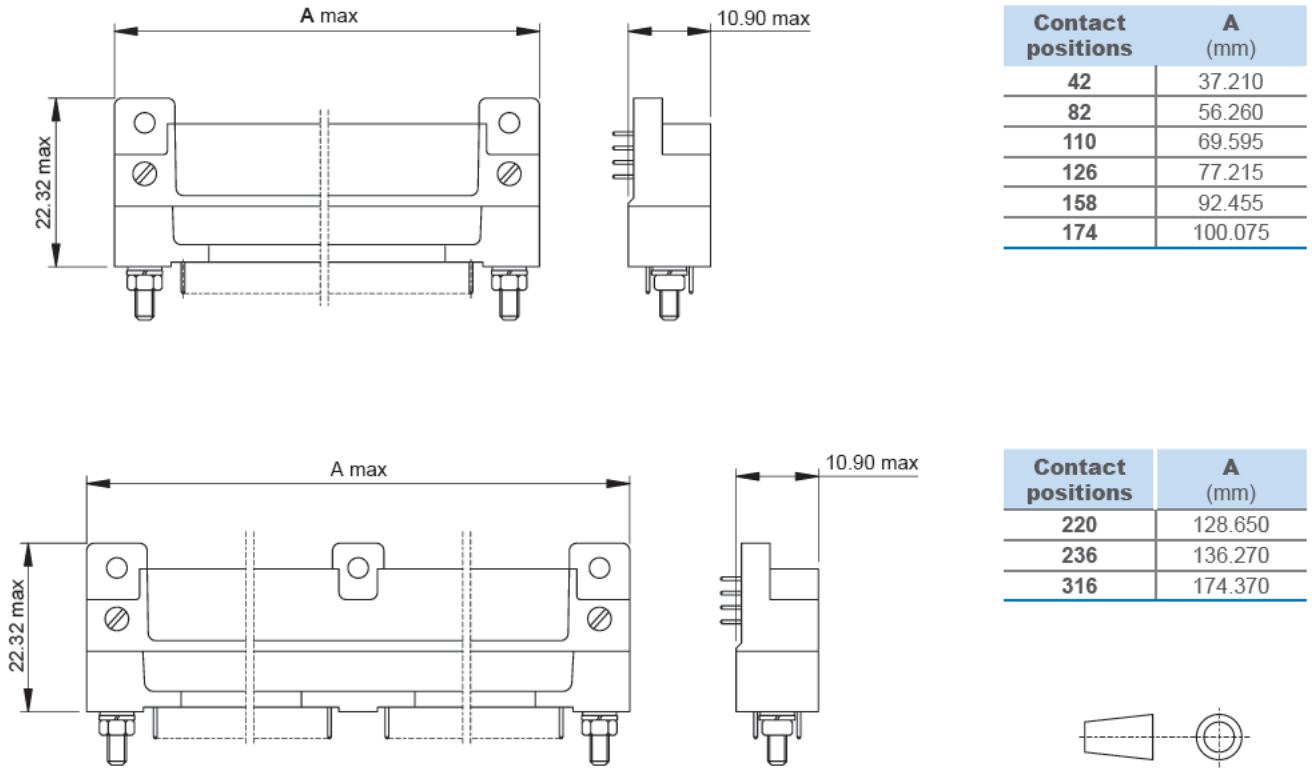

Figure 32

▶ **MAXIMUM DIMENSIONS OF MATED CONNECTORS**

**MAXIMUM DIMENSIONS OF MATED CONNECTORS.
PLUG AND RECEPTACLE CONNECTORS DIP SOLDER (RIGHT ANGLE), TERMINALS EQUIPPED**

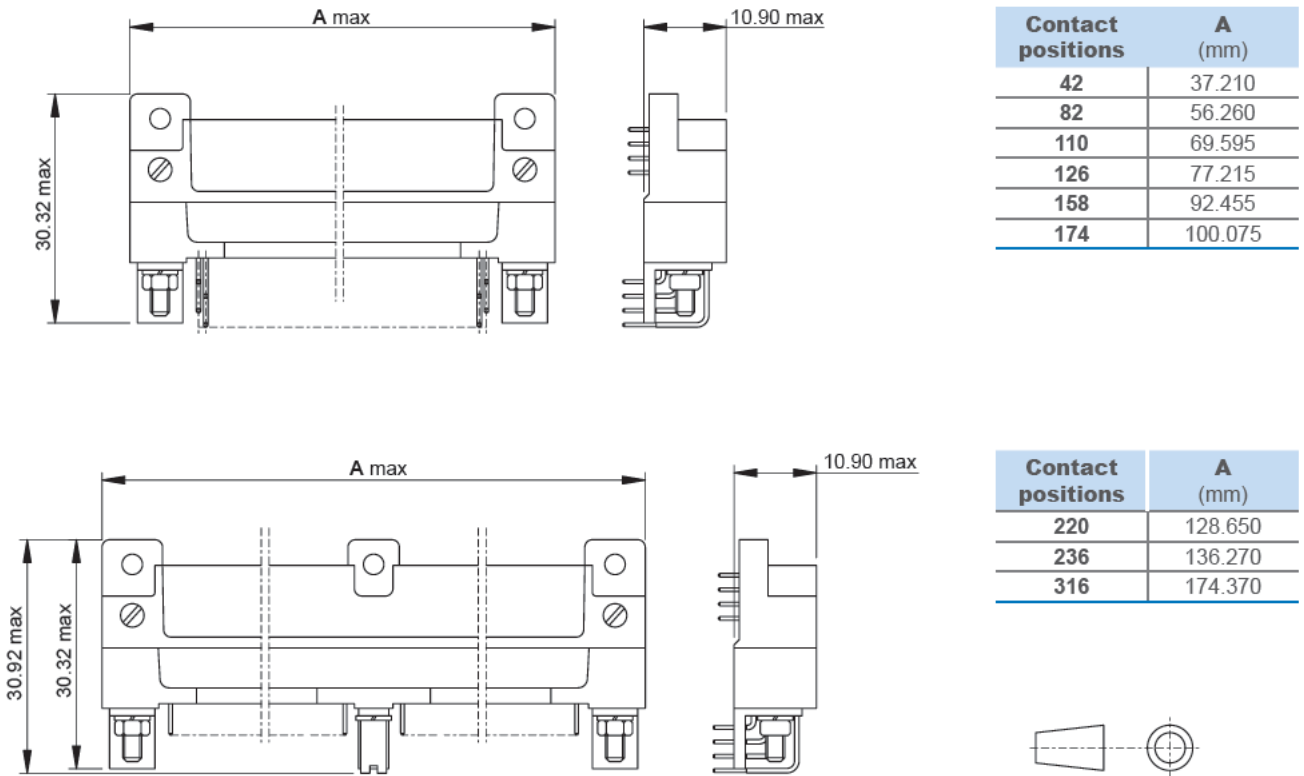
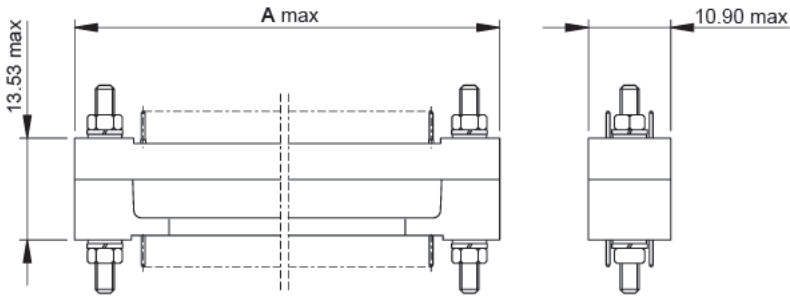

Figure 33

▶ MAXIMUM DIMENSIONS OF MATED CONNECTORS

**MAXIMUM DIMENSIONS OF MATED CONNECTORS.
PLUG AND RECEPTACLE CONNECTORS DIP SOLDER (STRAIGHT), TERMINALS EQUIPPED**



| Contact positions | A (mm) |
|-------------------|---------|
| 42 | 37.210 |
| 82 | 56.260 |
| 110 | 69.595 |
| 126 | 77.215 |
| 158 | 92.455 |
| 174 | 100.075 |

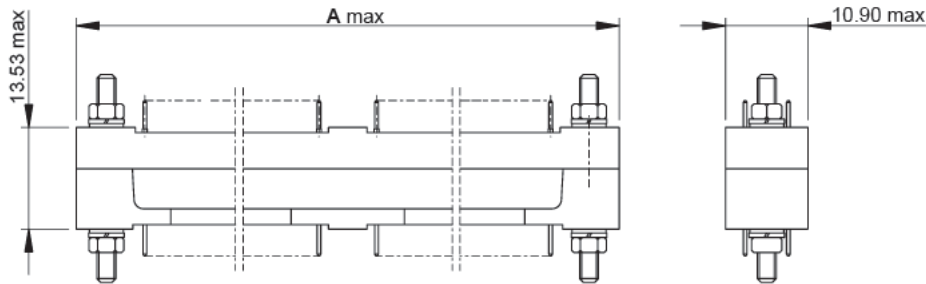

| Contact positions | A (mm) |
|-------------------|---------|
| 220 | 128.650 |
| 236 | 136.270 |
| 316 | 174.370 |

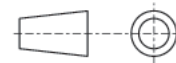
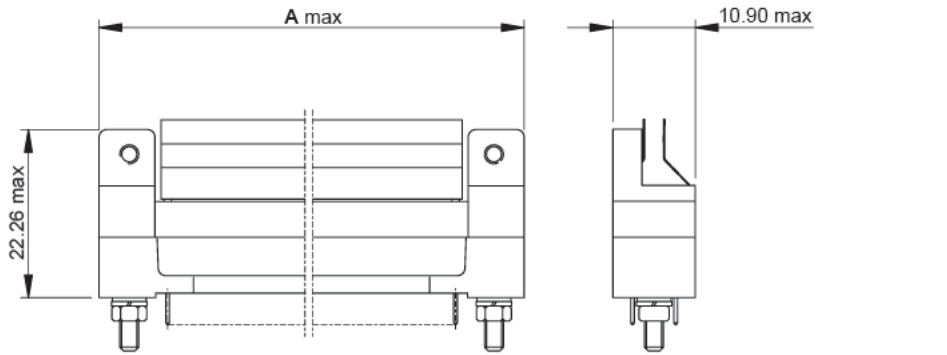

Figure 34

▶ **MAXIMUM DIMENSIONS OF MATED CONNECTORS**

**MAXIMUM DIMENSIONS OF MATED CONNECTORS.
PLUG CONNECTOR SURFACE MOUNT TAIL TERMINALS EQUIPPED
AND RECEPTACLE CONNECTOR DIP SOLDER (STRAIGHT), TERMINALS EQUIPPED**



| Contact positions | A (mm) |
|-------------------|---------|
| 42 | 37.210 |
| 82 | 56.260 |
| 110 | 69.595 |
| 126 | 77.215 |
| 158 | 92.455 |
| 174 | 100.075 |

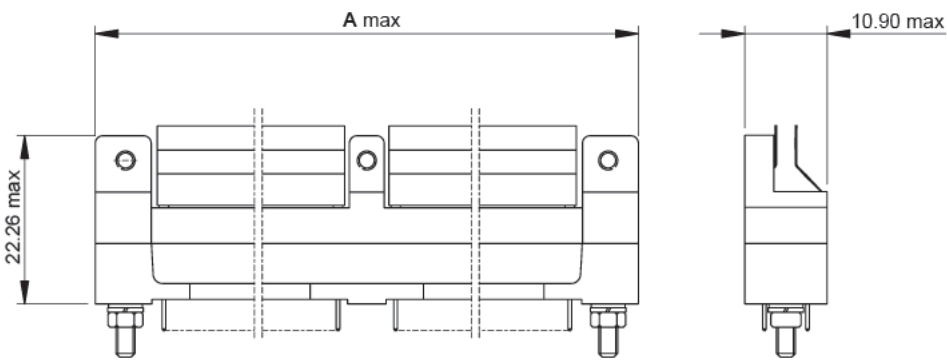

| Contact positions | A (mm) |
|-------------------|---------|
| 220 | 128.650 |
| 236 | 136.270 |
| 316 | 174.370 |

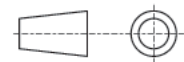

Figure 35

▶ **MAXIMUM DIMENSIONS OF MATED CONNECTORS**

**MAXIMUM DIMENSIONS OF MATED CONNECTORS.
PLUG AND RECEPTACLE CONNECTORS SURFACE MOUNT TAIL TERMINALS EQUIPPED**

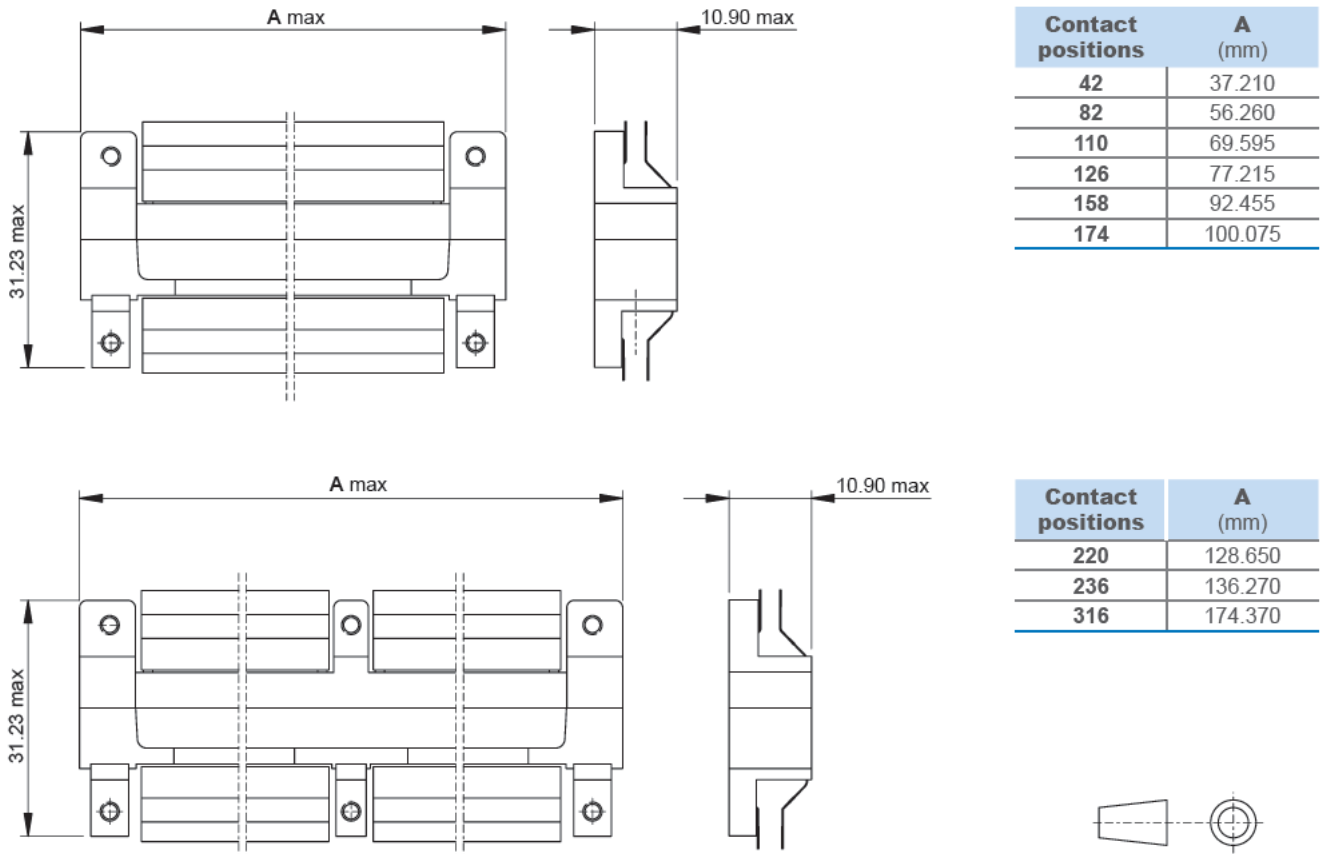
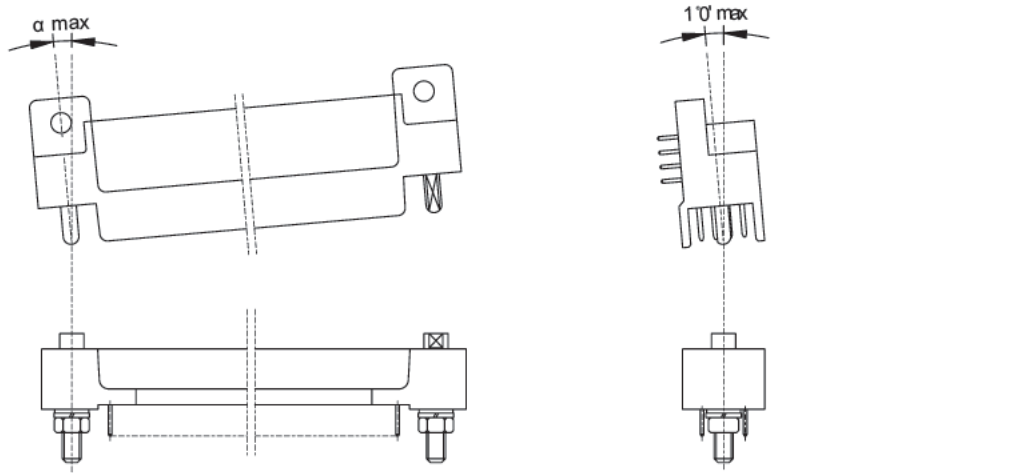

Figure 36

▶ THE CONNECTOR HALVES MATING

MAXIMUM PERMISSIBLE INCLINATION, IN LONGITUDINAL AND IN TRANSVERSAL AXIS, OF THE CONNECTOR HALVES, IN ORDER TO ENSURE THE ACCEPTABLE ELECTRICAL ENGAGEMENT MADE BY ALL CONTACTS



$\alpha = 0^{\circ} 25'$ for connectors equipped with 42, 82, 110, 126, 158 or 174 contact positions.

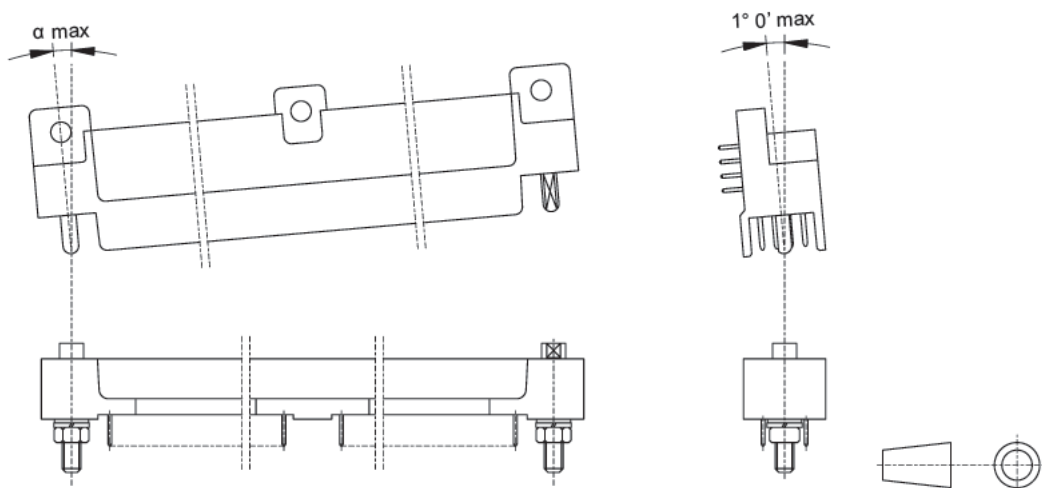

$\alpha = 0^{\circ} 11'$ for connectors equipped with 220 or 236 contact positions.
 $\alpha = 0^{\circ} 07'$ for connectors equipped with 316 contact positions.

Figure 37

▶ THE CONNECTOR HALVES MATING

MAXIMUM PERMISSIBLE DISPLACEMENT IN ORDER TO ENSURE THE SUITABLE FULLY INSERTION OF THE CONNECTOR HALVES

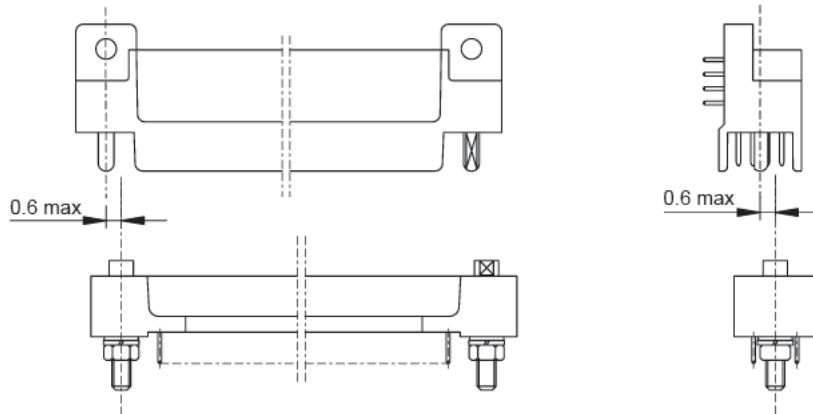

for connectors equipped with 42, 82, 110, 126, 158 or 174 contact positions.

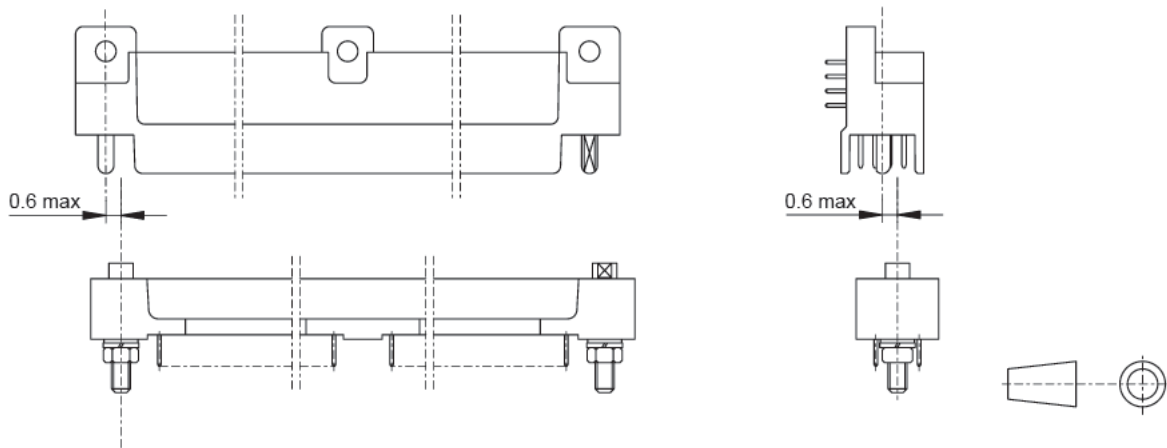

for connectors equipped with 220, 236 or 316 contact positions.

Figure 38

► THE CONNECTOR HALVES MATING

**MAXIMUM PERMISSIBLE DISTANCE OF THE CONNECTOR HALVES,
IN ORDER TO ENSURE THE ACCEPTABLE ELECTRICAL ENGAGEMENT MADE BY ALL CONTACTS**

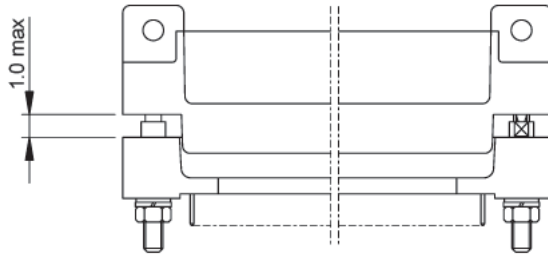

for connectors equipped with 42, 82, 110, 126, 158 or 174 contact positions.

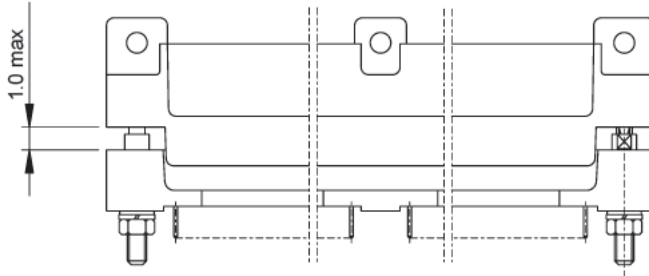

for connectors equipped with 220, 236 or 316 contact positions.

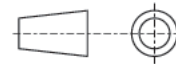

Figure 39

► CONNECTORS FOR MEASURING AND TEST

CONNECTORS FOR MEASURING AND TEST

Devices for measuring and test equipments are:

1. extender board, (as rigid vehicle);
2. cable assembly, (as flexible vehicle).

Connector for measuring and test inspection is:

3. card edge test connector, (as added connector wired on the PCB).

EXTENDER BOARD CONNECTORS

Extender board device is a rigid printed-wiring board with plug connector wired on one side, and receptacle connector wired on the other side of the board. Extender board device is a rigid vehicle for measuring and test equipments. Connectors for extender board device are equipped with unpolarized male guide pins, installed on plug connector, and omnipolarized female guide sockets, installed on receptacle connector, in such a manner that every mating, with any of several connectors having different polarization positions, becomes possible.

Connectors for extender board devices are:

- a. connectors with dip solder as contacts terminal, (thru hole solder connections); right angle mounting style;
- b. Connectors with surface mount tail as contacts terminal, (surface mount solder connections); straddle mounting style.

CABLE ASSEMBLY CONNECTORS

Cable assembly device is a cable with plug connector wired on one end, and receptacle connector wired on the other end. Cable assembly device is a flexible vehicle for measuring and test equipments. Connectors for cable assembly device are equipped with unpolarized male guide pins, installed on plug connector, and omnipolarized female guide sockets, installed on receptacle connector, in such a manner that every mating, with any of several connector having different polarization positions, becomes possible. Connectors for cable assembly device are connectors with hand solder, (solder cup), as contacts terminal. Maximum allowable wire size into solder cup terminal is AWG 26.

▶ HOW TO ORDER

a. connectors with dip solder as contacts terminal, (thru hole solder connections); right angle mounting style



1 ▶ CONNECTOR FAMILY

2 ▶ CONNECTOR SIZE

| | | |
|------------------------------------|------------------------------------|------------------------------------|
| 0 4 2 42 CONTACT POSITIONS | 0 8 2 82 CONTACT POSITIONS | 1 1 0 110 CONTACT POSITIONS |
| 1 2 6 126 CONTACT POSITIONS | 1 5 8 158 CONTACT POSITIONS | 1 7 4 174 CONTACT POSITIONS |
| 2 2 0 220 CONTACT POSITIONS | 2 3 6 236 CONTACT POSITIONS | |
| 3 1 6 316 CONTACT POSITIONS | | |

3 ▶ CONNECTOR AND CONTACTS STYLE

PM PLUG CONNECTOR PIN CONTACTS EQUIPPED **EF** RECEPTACLE CONNECTOR SOCKET CONTACTS EQUIPPED

4 ▶ CONTACT TERMINAL STYLE *Dip solder, right angle, with:*

A .109 INCH (2.76 MM) LONG DIP **B** .140 INCH (3.55 MM) LONG DIP **C** .172 INCH (4.37 MM) LONG DIP

5 ▶ HARDWARE CODE

P UNIVERSAL COUPLING GUIDE PINS ON PLUG CONNECTOR, OR UNIVERSAL COUPLING GUIDE SOCKETS ON RECEPTACLE CONNECTOR.

6 ▶ HARDWARE POLARIZATION

3 7 WHEN UNIVERSAL COUPLING GUIDE PINS ARE INSTALLED ON PLUG CONNECTOR, OR UNIVERSAL COUPLING GUIDE SOCKETS ARE INSTALLED ON RECEPTACLE CONNECTOR.

3 8 WHEN UNIVERSAL COUPLING GUIDE PINS, FOR PLUG CONNECTOR, OR UNIVERSAL COUPLING GUIDE SOCKETS, FOR RECEPTACLE CONNECTOR, ARE SHIPPED LOOSE IN A PLASTIC BAG.

7 ▶ CONTACT FINISHING

H CONTACTS WITH PLATING AND UNDERPLATING CONFORMING TO MIL-C-55302

NOTE

See figures 2, 3, 15, 16, 17, 18, 30 and 31 of this catalog.

▶ HOW TO ORDER

b. Connectors with surface mount tail as contacts terminal, (surface mount solder connections); straddle mounting style



1 ▶ CONNECTOR FAMILY

2 ▶ CONNECTOR SIZE

| | | |
|---|--|------------------------------------|
| CHECK FIRM 42 CONTACT POSITIONS | CHECK FIRM 82 CONTACT POSITIONS | 1 1 0 110 CONTACT POSITIONS |
| CHECK FIRM 126 CONTACT POSITIONS | 1 5 8 158 CONTACT POSITIONS | 1 7 4 174 CONTACT POSITIONS |
| CHECK FIRM 220 CONTACT POSITIONS | 2 3 6 236 CONTACT POSITIONS | 3 1 6 316 CONTACT POSITIONS |

3 ▶ CONNECTOR AND CONTACTS STYLE

PM PLUG CONNECTOR PIN CONTACTS EQUIPPED **EF** RECEPTACLE CONNECTOR SOCKETS CONTACTS EQUIPPED

4 ▶ CONTACT TERMINAL STYLE *Flex circuit for straddle mount, with board package thickness:*

| | |
|--|--|
| N FROM .039 TO .079 INCH (FROM 1.00 TO 2.00 MM) | R FROM .067 TO .106 INCH (FROM 1.70 TO 2.70 MM) |
| T FROM .106 TO .146 INCH (FROM 2.70 TO 3.70 MM) | V FROM .126 TO .165 INCH (FROM 3.20 TO 4.20 MM) |

5 ▶ HARDWARE CODE

P UNIVERSAL COUPLING GUIDE PINS ON PLUG CONNECTOR, OR UNIVERSAL COUPLING GUIDE SOCKETS ON RECEPTACLE CONNECTOR.

6 ▶ HARDWARE POLARIZATION

3 7 WHEN UNIVERSAL COUPLING GUIDE PINS ARE INSTALLED ON PLUG CONNECTOR, OR UNIVERSAL COUPLING GUIDE SOCKETS ARE INSTALLED ON RECEPTACLE CONNECTOR.

3 8 WHEN UNIVERSAL COUPLING GUIDE PINS, FOR PLUG CONNECTOR, OR UNIVERSAL COUPLING GUIDE SOCKETS, FOR RECEPTACLE CONNECTOR, ARE SHIPPED LOOSE IN A PLASTIC BAG.

7 ▶ CONTACT FINISHING

H CONTACTS WITH PLATING AND UNDERPLATING CONFORMING TO MIL-C-55302

NOTE

See figures 6, 7, 8, 12, 13, 14, 21, 22, 23, 27, 28 and 29 of this catalog.

CONNECTORS FOR MEASURING AND TEST

PLUG CONNECTOR: 42, 82, 110, 126, 158 AND 174 PIN CONTACT POSITIONS, .075 INCH SPACING, (1.905 MM), SOLDER CUP PIN CONTACT TERMINALS, FOR CABLE ASSEMBLY APPLICATIONS

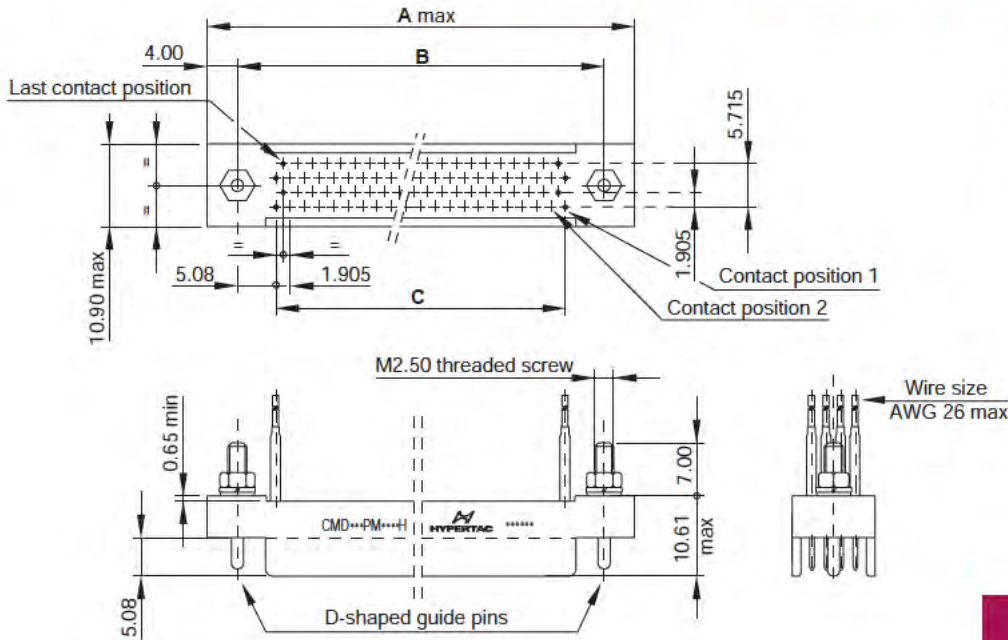

NOTES:
 1. see dimensions in width in the table on this page.
 2. lead length = 2ft

Figure 40

RECEPTACLE CONNECTOR: 42, 82, 110, 126, 158 AND 174 SOCKET CONTACT POSITIONS, .075 INCH SPACING (1.905 MM), SOLDER CUP SOCKET CONTACT TERMINALS, FOR CABLE ASSEMBLY APPLICATIONS

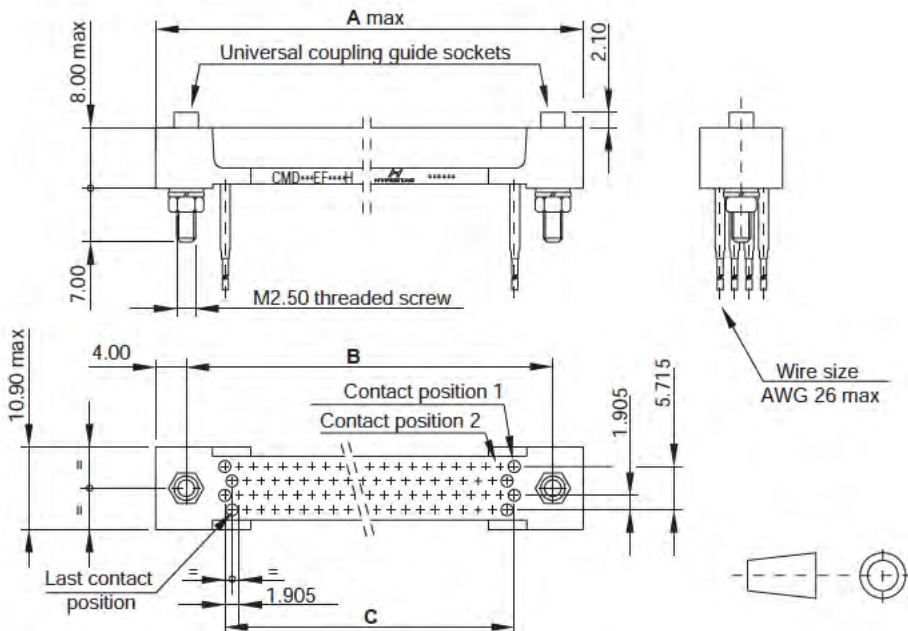

NOTES:
 1. see dimensions in width in the table on this page.
 2. lead length = 2ft.

Figure 41

| Dimensions in width | | | |
|---------------------|---------|--------|--------|
| Contact positions | A (mm) | B (mm) | C (mm) |
| 42 | 37.210 | 29.210 | 19.050 |
| 82 | 56.260 | 48.260 | 38.100 |
| 110 | 69.595 | 61.595 | 51.435 |
| 126 | 77.215 | 69.215 | 59.055 |
| 158 | 92.455 | 84.455 | 74.295 |
| 174 | 100.075 | 92.075 | 81.915 |

CONNECTORS FOR MEASURING AND TEST

PLUG CONNECTOR: 220, 236 AND 316 PIN CONTACT POSITIONS, .075 INCH SPACING (1.905 MM), SOLDER CUP PIN CONTACT TERMINALS, FOR CABLE ASSEMBLY APPLICATIONS

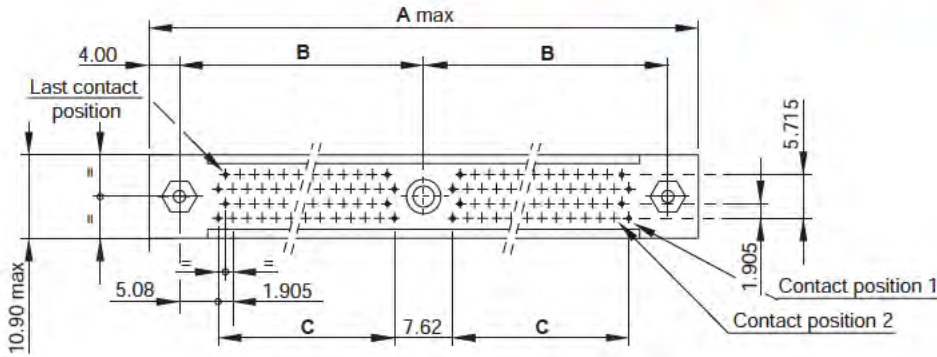

- NOTES:**
 1. see dimensions in width in the table on this page.
 2. lead length = ft.

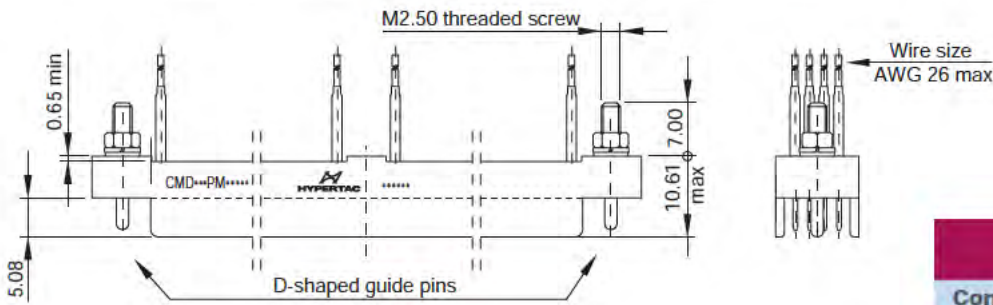
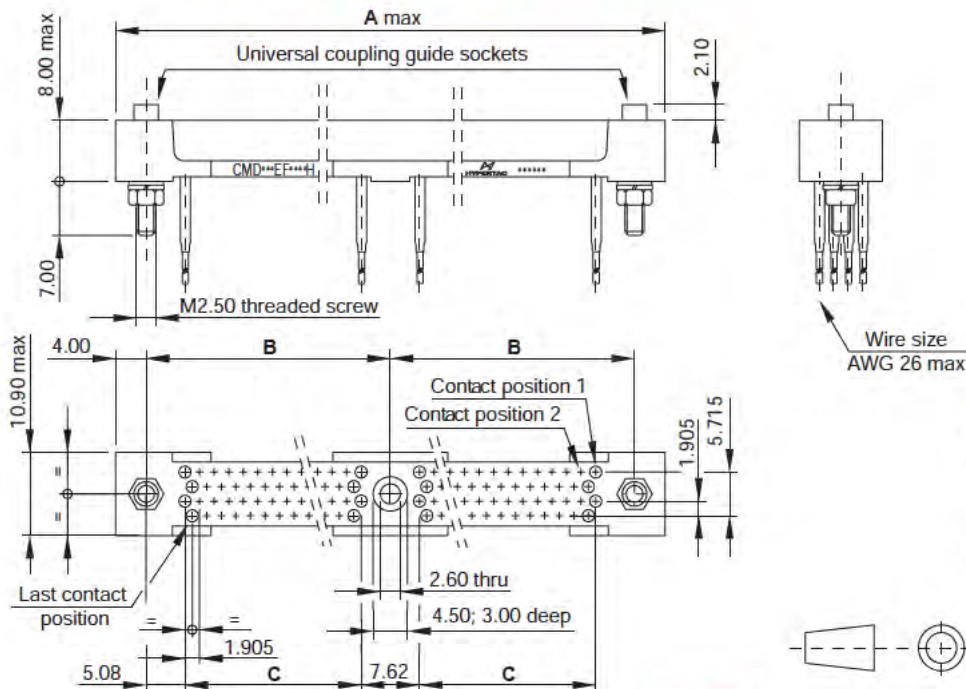

Figure 42

| Dimensions in width | | | |
|---------------------|---------|--------|--------|
| Contact positions | A (mm) | B (mm) | C (mm) |
| 220 | 128.650 | 60.325 | 51.435 |
| 236 | 136.270 | 64.135 | 55.245 |
| 316 | 174.370 | 83.185 | 74.295 |

RECEPTACLE CONNECTOR: 220, 236 AND 316 SOCKET CONTACT POSITIONS, .075 INCH SPACING (1.905 MM), SOLDER CUP SOCKET CONTACT TERMINALS, FOR CABLE ASSEMBLY APPLICATIONS



- NOTES:**
 1. see dimensions in width in the table on this page.
 2. lead length = 2ft.

Figure 43

▶ HOW TO ORDER



1 ▶ CONNECTOR FAMILY

2 ▶ CONNECTOR SIZE - All sizes are available for receptacle connectors, for plug connectors check firm

| | | |
|------------------------------------|------------------------------------|------------------------------------|
| 0 4 2 42 CONTACT POSITIONS | 0 8 2 82 CONTACT POSITIONS | 1 1 0 110 CONTACT POSITIONS |
| 1 2 6 126 CONTACT POSITIONS | 1 5 8 158 CONTACT POSITIONS | 1 7 4 174 CONTACT POSITIONS |
| 2 2 0 220 CONTACT POSITIONS | 2 3 6 236 CONTACT POSITIONS | 3 1 6 316 CONTACT POSITIONS |

3 ▶ CONNECTOR AND CONTACTS STYLE

PM PLUG CONNECTOR PIN CONTACTS EQUIPPED **EF** RECEPTACLE CONNECTOR SOCKETS CONTACT EQUIPPED

4 ▶ CONTACT TERMINAL STYLE

W CRIMP TERMINAL STYLE, LEAD ATTACHED (*wire size AWG 26 max*)

5 ▶ HARDWARE CODE

P UNIVERSAL COUPLING GUIDE PINS ON PLUG CONNECTOR, OR UNIVERSAL COUPLING GUIDE SOCKETS ON RECEPTACLE CONNECTOR.

6 ▶ HARDWARE POLARIZATION

3 7 WHEN UNIVERSAL COUPLING GUIDE PINS ARE INSTALLED ON PLUG CONNECTOR, OR UNIVERSAL COUPLING GUIDE SOCKETS ARE INSTALLED ON RECEPTACLE CONNECTOR.

3 8 WHEN UNIVERSAL COUPLING GUIDE PINS, FOR PLUG CONNECTOR, OR UNIVERSAL COUPLING GUIDE SOCKETS, FOR RECEPTACLE CONNECTOR, ARE SHIPPED LOOSE IN A PLASTIC BAG.

7 ▶ CONTACT FINISHING

H CONTACTS WITH PLATING AND UNDERPLATING CONFORMING TO MIL-C-55302

CARD EDGE TEST CONNECTOR

Card edge test connector is a special connector, added and wired on the PCB for test and measuring "in line" of microelectronic devices. Card edge test connector allows to have special points of access to an electrical circuit used for testing purposes.

Card edge test connector assembly consist of:

1. plug connector, socket contacts equipped, "free to move";
2. receptacle connector, pin contacts equipped, fixed and soldered to the PCB. Card edge test connector assembly features:
 - contact positions are 49 in all;
 - contact arrangement is offset grid pattern within dielectric connector body;

- contact spacing in each row is .075 INCH (1.905 mm), center-to-center;
- row-to-row spacing is 0.75 INCH (1.905 mm), center-to-center;
- contact size 0.6 mm nominal pin DIA;
- polarization feature is incorporated in each connector assembly to assure correct insertion;
- turn locking hardware retains plug connector in the mating position;
- every other requirement is specified on **pages 4 and 5** of this catalog.

► FLEX CIRCUIT SOLDERING

SUGGESTED TEMPERATURE VARIATION IN HOT BAR SOLDERING PROCESS

Graphical representation of hot bar suggested temperature variation, during flex circuit tails, and rigid printed wiring lands contacts, soldering

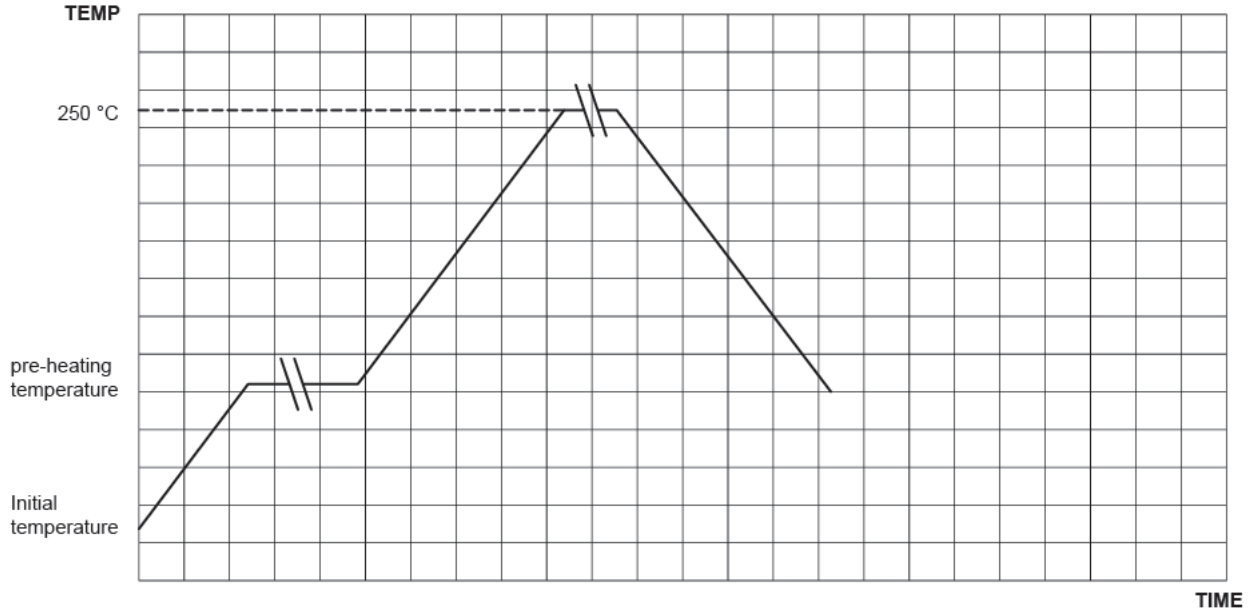

Figure 44

Soldering profile shall be defined and optimized in relation with the characteristics of the soldering equipment and of the daughterboard features (i.e. board package thickness, composite board type, heat sink thickness, microelectronic device density etc.).

CONFORMAL COATING AFTER SOLDERING

Surface mount flex circuit tails, and rigid printed wiring land contacts, must be conformally coated, after soldering and cleaning, of a suitable electrical insulating compound as specified in MIL-I-46058 document (latest issue).

Disclaimer 2014

All of the information included in this catalogue is believed to be accurate at the time of printing. It is recommended, however, that users should independently evaluate the suitability of each product for their intended application and be sure that each product is properly installed, used and maintained to achieve desired results.

Smiths Connectors makes no warranties as to the accuracy or completeness of the information, and disclaims any liability regarding its use.

Smiths Connectors reserves the right to modify design and specifications, in order to improve quality, keep pace with technological development or meet specific production requirements.

No reproduction or use without express permission of editorial and pictorial content, in any manner.

SMITHS CONNECTORS PRODUCT LINES

Circular



- ▶ Metal and plastic
- ▶ Industrial M12, M23, M40, M58
- ▶ Crimp and solder terminations
- ▶ Push/pull latch mechanism
- ▶ Color coding

EMI / EMP Filter



- ▶ EMI/RFI filtering and transient protection
- ▶ RoHS compliant solderless filter connectors available
- ▶ Filtered adapter for "bolt on" EMI/EMP solutions
- ▶ Filter hybrid capability
- ▶ Circular, ARINC, D-Subminiature, Micro-D

Heavy Duty



- ▶ Modular solution: signal, power, data contacts and fiber optics
- ▶ EMC shielding
- ▶ High pressure up to 35K PSI, 250°C
- ▶ High temperature up to 440°C

High Power



- ▶ Single and multi-way
- ▶ Circular and configurable rectangular
- ▶ Power contact up to 1,200 Amps
- ▶ Excellent performance in harsh environments

High Speed Copper / Fiber



- ▶ Quadrax and Twinax connectors
- ▶ Fiber Optic Butt Joint, Expanded Beam and Floating Fiber Termini available
- ▶ ARINC and MIL-STD contacts

Mil / Aero Standards



- ▶ Standard military interface
- ▶ ARINC 801
- ▶ ARINC interface
- ▶ Custom inserts

Modular / Rectangular



- ▶ Configurable modules for signal, power, coax, fiber optic and/or pneumatics
- ▶ Guided hardware for blind mating
- ▶ Easy configuration in a single frame
- ▶ For rack & panel and cable applications

PCB



- ▶ Low, medium and high density board-to-board, cable to board and stacking
- ▶ Signal, power, coax and high speed configurations
- ▶ Numerous termination styles

Spring Probe



- ▶ Z-axis compliant
- ▶ Blind mate engagement
- ▶ High density
- ▶ Extreme miniaturization
- ▶ High reliability, multi-cycle performance



SMITHS CONNECTORS

GLOBAL SUPPORT

AMERICAS

info.us@smithsconnectors.com

Costa Mesa, CA
1.714.371.1100

Hudson, MA
1.978.568.0451

Kansas City, KS
1.913.342.5544

EUROPE

France

33.2.32969176
info.fr@smithsconnectors.com

Germany

49.991.250.120
info.de@smithsconnectors.com

Italy

39.010.60361
info.it@smithsconnectors.com

United Kingdom

44.208.236.2400
info.uk@smithsconnectors.com

ASIA

asiainfo@smithsconnectors.com

Shanghai, China
86.21.3318.4650

Suzhou, China
86.512.6273.1188

Singapore
65.6846.1655

visit us at | smithsconnectors.com |     

Copyright© 2016 Smiths Connectors | All rights reserved | Version 1.1