

Features

- ✧ Glass passivated junction chip
- ✧ For surface mounted application
- ✧ Low profile package
- ✧ Built-in strain relief
- ✧ Ideal for automated placement
- ✧ Easy pick and place
- ✧ Super fast recovery time for high efficiency
- ✧ Glass passivated chip junction
- ✧ High temperature soldering:
260°C/10 seconds at terminals
- ✧ Meet MSL level 1, per J-STD-020D
lead free, maximum peak of 260°C
- ✧ Plastic material used carries Underwriters
Laboratory Classification 94V-0
- ✧ Green compound with suffix "G" on packing
code & prefix "G" on datecode



Mechanical Data

- ✧ Cases: Molded plastic
- ✧ Terminals: Pure tin plated, lead free
- ✧ Polarity: Indicated by cathode band
- ✧ Packing: 12mm tape per EIA STD RS-481
- ✧ Weight: 0.064 grams

Ordering Information (example)

Part No.	Package	Packing	Packing code	Packing code (Green)
ES1A	SMA	1.8K / 7" REEL	R3	R3G

Maximum Ratings and Electrical Characteristics

Rating at 25 °C ambient temperature unless otherwise specified.

Parameter	Symbol	ES 1A	ES 1B	ES 1C	ES 1D	ES 1F	ES 1G	ES 1H	ES 1J	Units	
Maximum Recurrent Peak Reverse Voltage	V_{RRM}	50	100	150	200	300	400	500	600	V	
Maximum RMS Voltage	V_{RMS}	35	70	105	140	210	280	350	420	V	
Maximum DC Blocking Voltage	V_{DC}	50	100	150	200	300	400	500	600	V	
Maximum Average Forward Rectified Current	$I_{F(AV)}$	1								A	
Peak Forward Surge Current, 8.3 ms Single Half Sine-wave Superimposed on Rated Load (JEDEC method)	I_{FSM}	30								A	
Maximum Instantaneous Forward Voltage (Note 1) @ 1 A	V_F	0.95			1.3		1.7			V	
Maximum DC Reverse Current at Rated DC Blocking Voltage @ $T_A=25\text{ }^\circ\text{C}$ @ $T_A=125\text{ }^\circ\text{C}$	I_R	5					100				uA uA
Maximum Reverse Recovery Time (Note 2)	T_{rr}	35								nS	
Typical Junction Capacitance (Note 3)	C_j	16				18				pF	
Maximum Thermal Resistance	$R_{\theta JA}$ $R_{\theta JL}$	85 35								$^\circ\text{C/W}$	
Operating Temperature Range	T_J	- 55 to + 150								$^\circ\text{C}$	
Storage Temperature Range	T_{STG}	- 55 to + 150								$^\circ\text{C}$	

Note 1: Pulse Test with PW=300 usec, 1% Duty Cycle

Note 2: Reverse Recovery Test Conditions: $I_F=0.5\text{A}$, $I_R=1.0\text{A}$, $I_{RR}=0.25\text{A}$

Note 3: Measured at 1 MHz and Applied $V_R=4.0\text{ Volts}$

RATINGS AND CHARACTERISTIC CURVES (ES1A THRU ES1J)

FIG.1- MAXIMUM FORWARD CURRENT DERATING CURVE

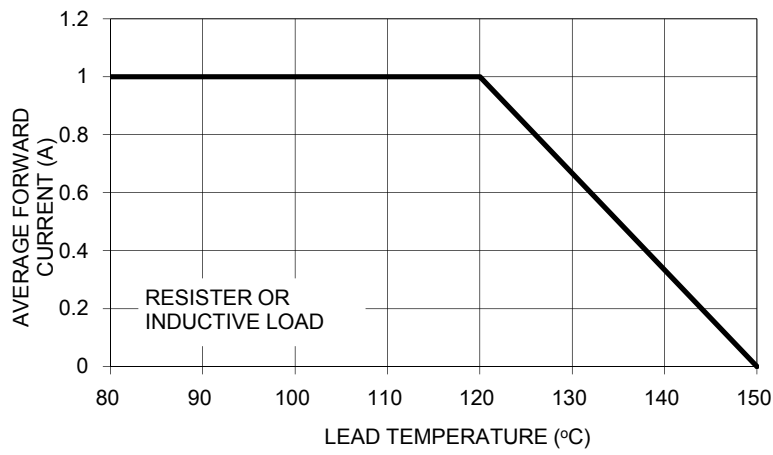

FIG. 2- TYPICAL INSTANTANEOUS FORWARD CHARACTERISTICS

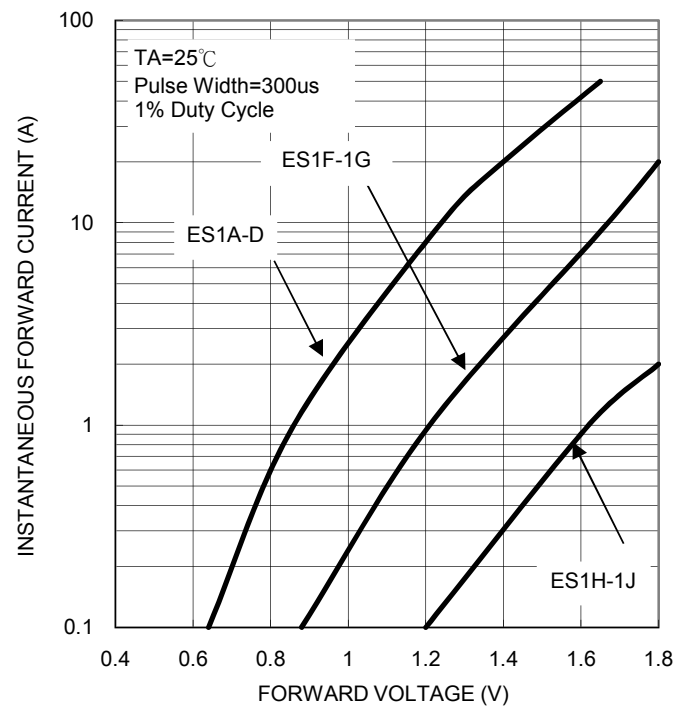

FIG. 3- MAXIMUM NON-REPETITIVE FORWARD PEAK SURGE CURRENT

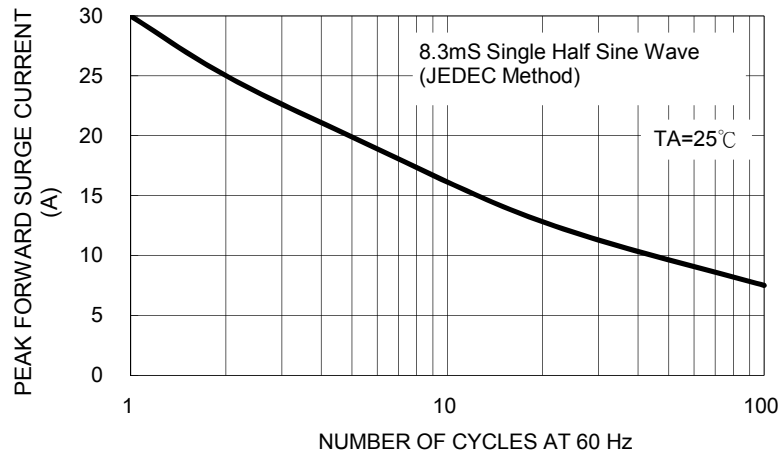

FIG. 5- TYPICAL REVERSE CHARACTERISTICS

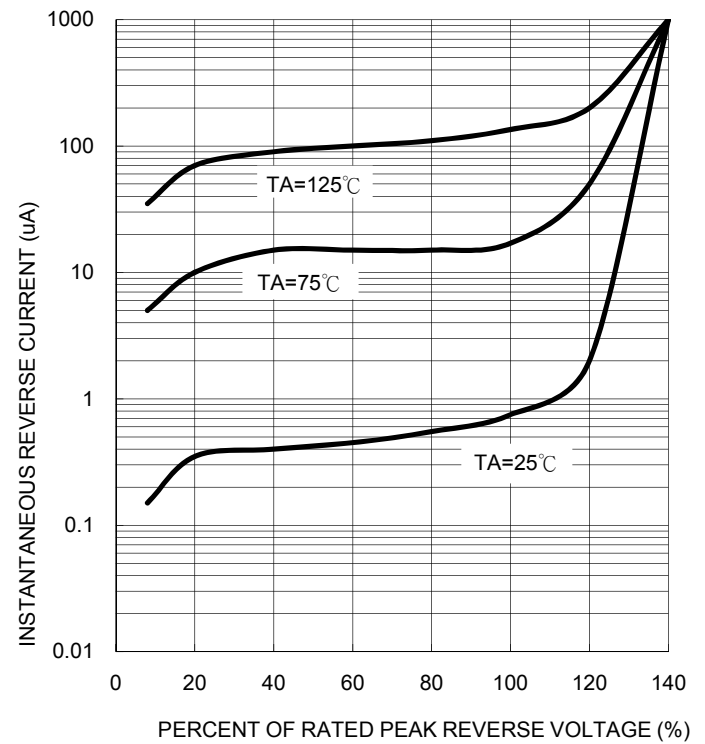

FIG. 4- TYPICAL JUNCTION CAPACITANCE

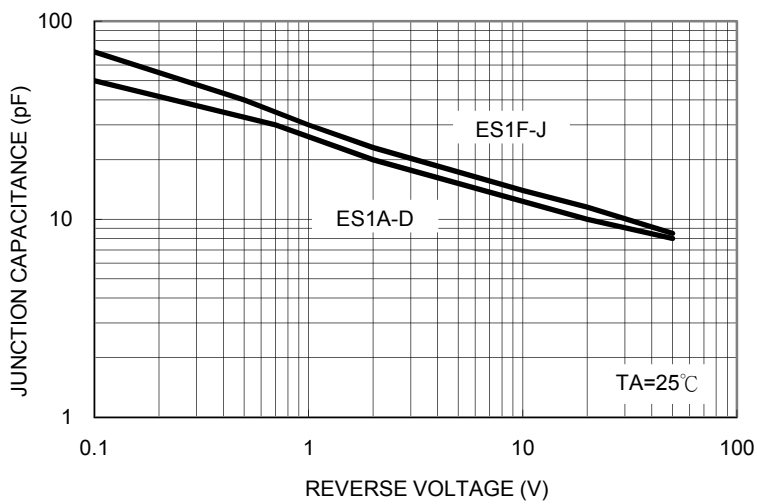
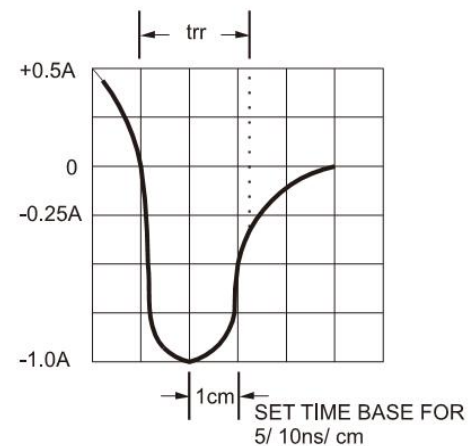
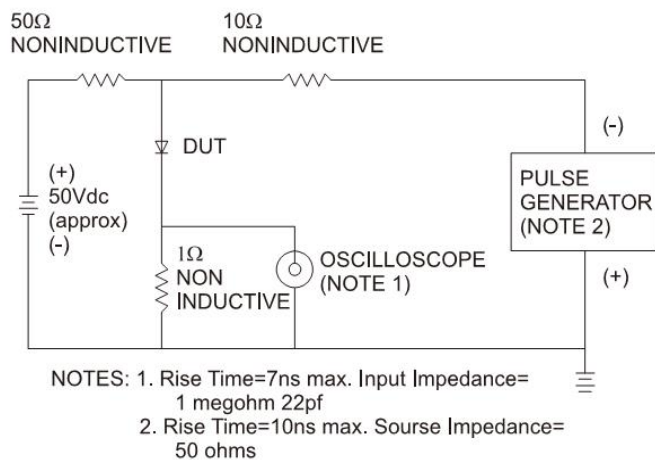

FIG.6- REVERSE RECOVERY TIME CHARACTERISTIC AND TEST CIRCUIT DIAGRAM



Ordering information

Part No.	Package	Packing	Packing code	Packing code (Green)
ES1X (Note)	SMA	1.8K / 7" REEL	R3	R3G
	SMA	7.5K / 13" REEL	R2	R2G
	SMA	7.5K / 13" Plastic REEL	M2	M2G
	Folded SMA	1.8K / 7" REEL	F3	F3G
	Folded SMA	7.5K / 13" REEL	F2	F2G
	Folded SMA	7.5K / 13" Plastic REEL	F4	F4G
	C SMA	1.8K / 7" REEL	E3	E3G
	C SMA	7.5K / 13" REEL	E2	E2G

Note: "x" is Device Code from "A" thru "J".

Tape & Reel specification

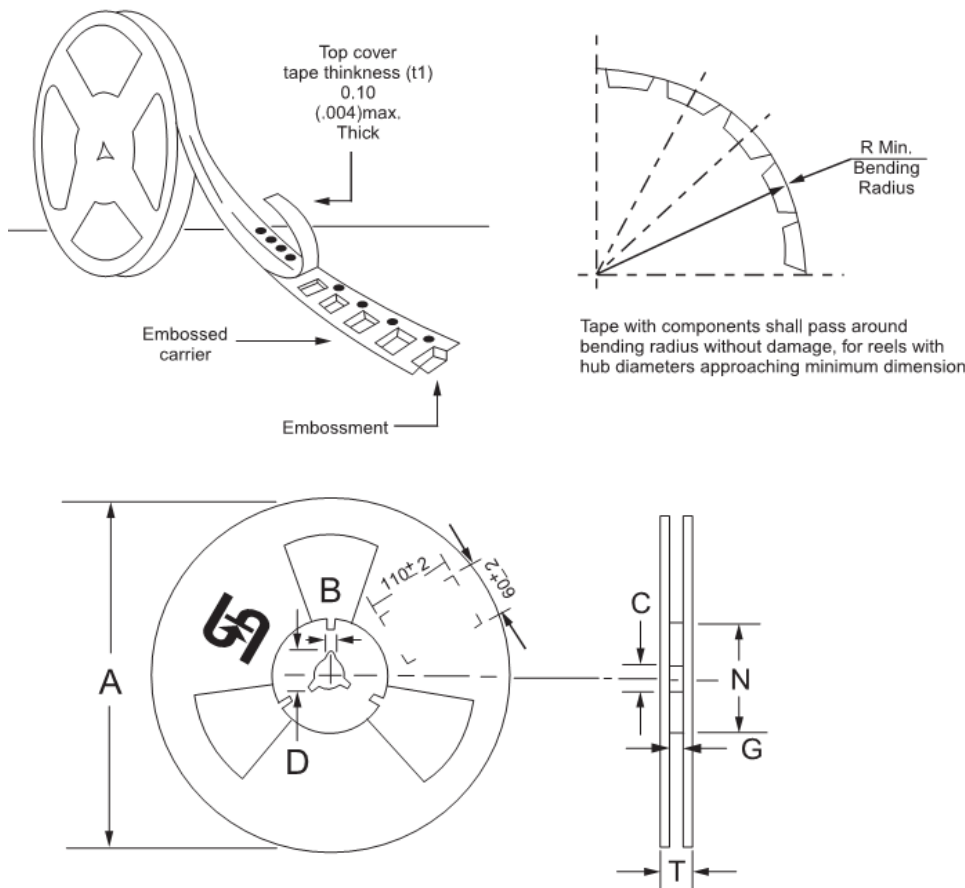

Reel Size	Tape Size	A	B	C	D	N	G	T
		±2.0	±0.4	+0.5;-0.2	min	±1.0	+0.8;-0	max
7"	12mm	178	1.9	13	21	62	12.2	14.6
Reel Size	Tape Size	A	B	C	D	N	G	T
		max	±0.5	±0.5	min	±0.5	+2.0;-0	max
13"	12mm	330	2	13	20.2	75	12.4	18.4

Unit (mm)

Suggested PAD Layout

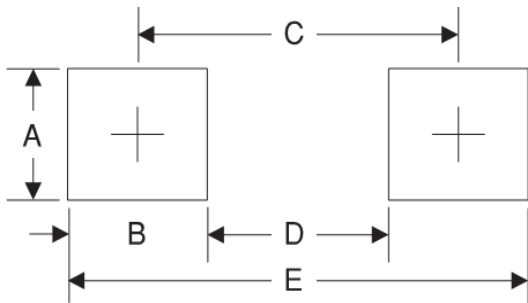

Symbol	Unit(mm)
A	1.78
B	1.51
C	3.92
D	2.41
E	4.43

Package Outline Dimensions

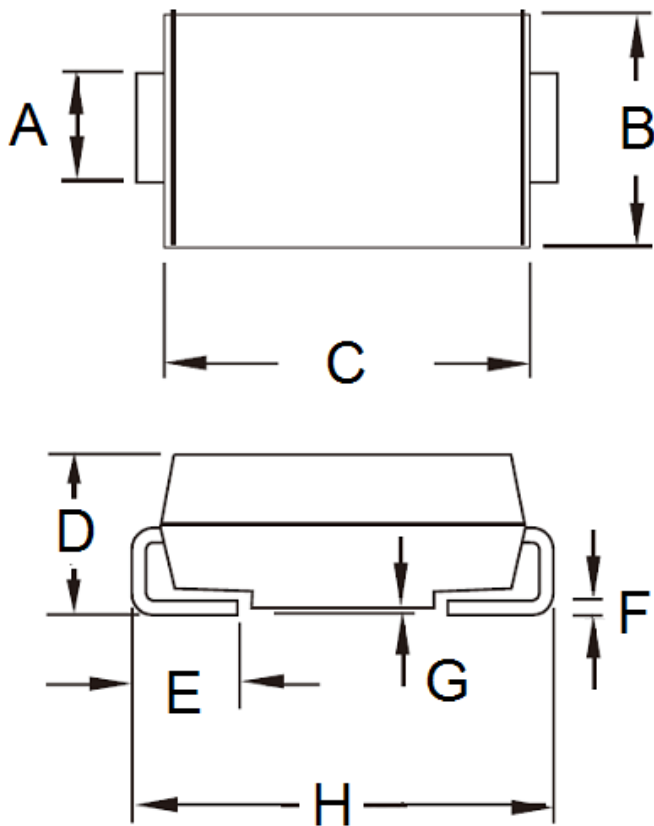

DIM.	Unit(mm)		Unit(inch)	
	Min	Max	Min	Max
A	1.27	1.58	0.050	0.062
B	2.29	2.83	0.090	0.111
C	4.06	4.60	0.160	0.181
D	1.99	2.50	0.078	0.098
E	0.90	1.41	0.035	0.056
F	0.15	0.31	0.006	0.012
G	0.10	0.20	0.004	0.008
H	4.95	5.33	0.195	0.210

Marking Diagram



P/N = Specific Device Code
 G = Green Compound
 YW = Date Code
 F = Factory Code