

DO NOT SCALE FROM THIS PRINT

- NOTES:
 1. VITA 88, -19 POSITION WITH -11.0 BODY HEIGHT IS NOT AVAILABLE AS STANDARD.
 2. Ⓢ REPRESENTS A CRITICAL DIMENSION.
 3. MINIMUM PUSHOUT FORCE: .50 LBS
 4. DIMENSION MUST BE MEASURED USING INSPECTION FIXTURE AT-1817-836-2. USE CO-AU-WI-2003-M FOR PROCESS.
 5. MEASURED FIRST & LAST POSITIONS ONLY, ALL ROWS.
 6. PARTS TO BE PACKAGED IN TAPE & REEL. ATTACH LABEL "SEAX-0001" TO EACH TAPE & REEL PACKAGE.
 7. ORDERS WILL BE PACKAGED ACCORDING TO THE SAMTEC PACKAGING EFFICIENCY STANDARDS (SPES) FOUND ON WWW.SAMTEC.COM.
 8. ATTACH LABEL -4x2 TO EACH REEL.

ANY REVISION MADE TO THIS PRINT MUST HAVE AN UPDATED MKT PRINT

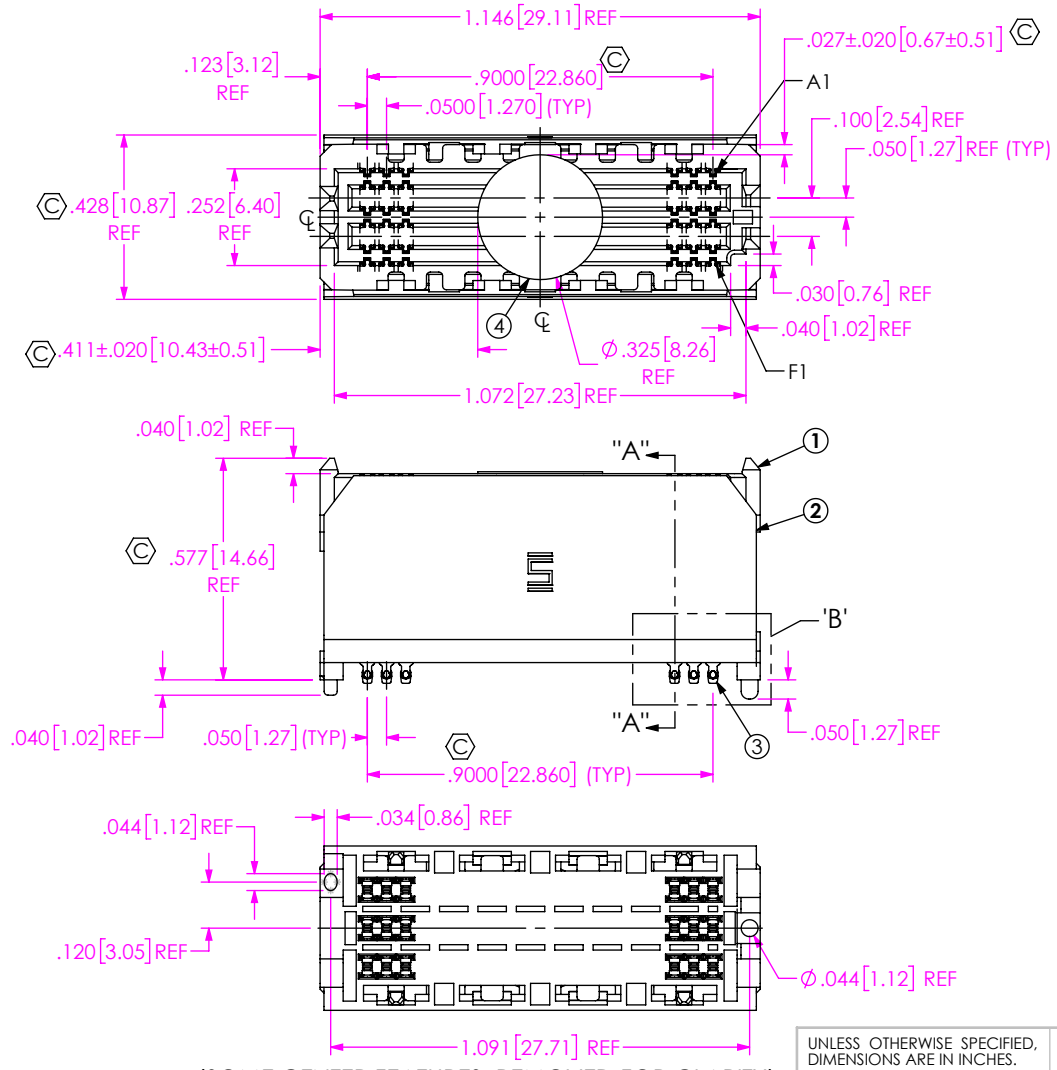
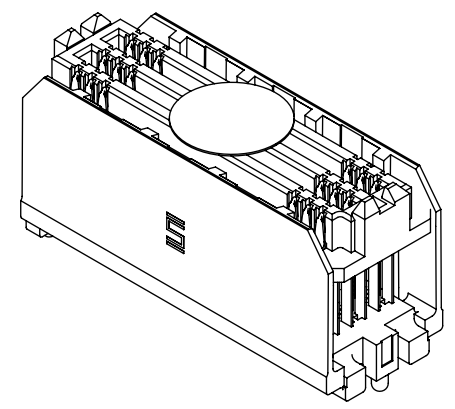

UNLESS OTHERWISE SPECIFIED, DIMENSIONS ARE IN INCHES. TOLERANCES ARE: DECIMALS ANGLES .XX: ±.01 [0.3] .XXX: ±.005 [0.13] .XXXX: ±.0020 [0.051]	* PROPRIETARY NOTE * THIS DOCUMENT CONTAINS CONFIDENTIAL AND PROPRIETARY INFORMATION AND ALL DESIGN, MANUFACTURING, REPRODUCTION, USE, PATENT RIGHTS AND SALES RIGHTS ARE EXPRESSLY RESERVED BY SAMTEC, INC. THIS DOCUMENT SHALL NOT BE DISCLOSED, IN WHOLE OR PART, TO ANY UNAUTHORIZED PERSON OR ENTITY NOR REPRODUCED, TRANSFERRED OR INCORPORATED IN ANY OTHER PROJECT IN ANY MANNER WITHOUT THE EXPRESS WRITTEN CONSENT OF SAMTEC, INC.	<p>520 PARK EAST BLVD, NEW ALBANY, IN 47150 PHONE: 812-944-6733 FAX: 812-948-5047 e-Mail: info@SAMTEC.com code: 55322</p>

ITEM NO.	PART NUMBER	QUANTITY	MATERIAL
1	ASP-213637-01-B	1.0000	LCP, COLOR: BLACK
2	ASP-213645-01-B	1.0000	LCP, COLOR: BLACK
3	NEW-SUB-T-1M38-11.0-STL-1	114.00	BeCu/LEAD SOLDER
4	K-DOT-.325-.450-.005	1.0000	POLYIMIDE FILM
5	CT-ASP5763MS	.01000	CONDUCTIVE POLYMER

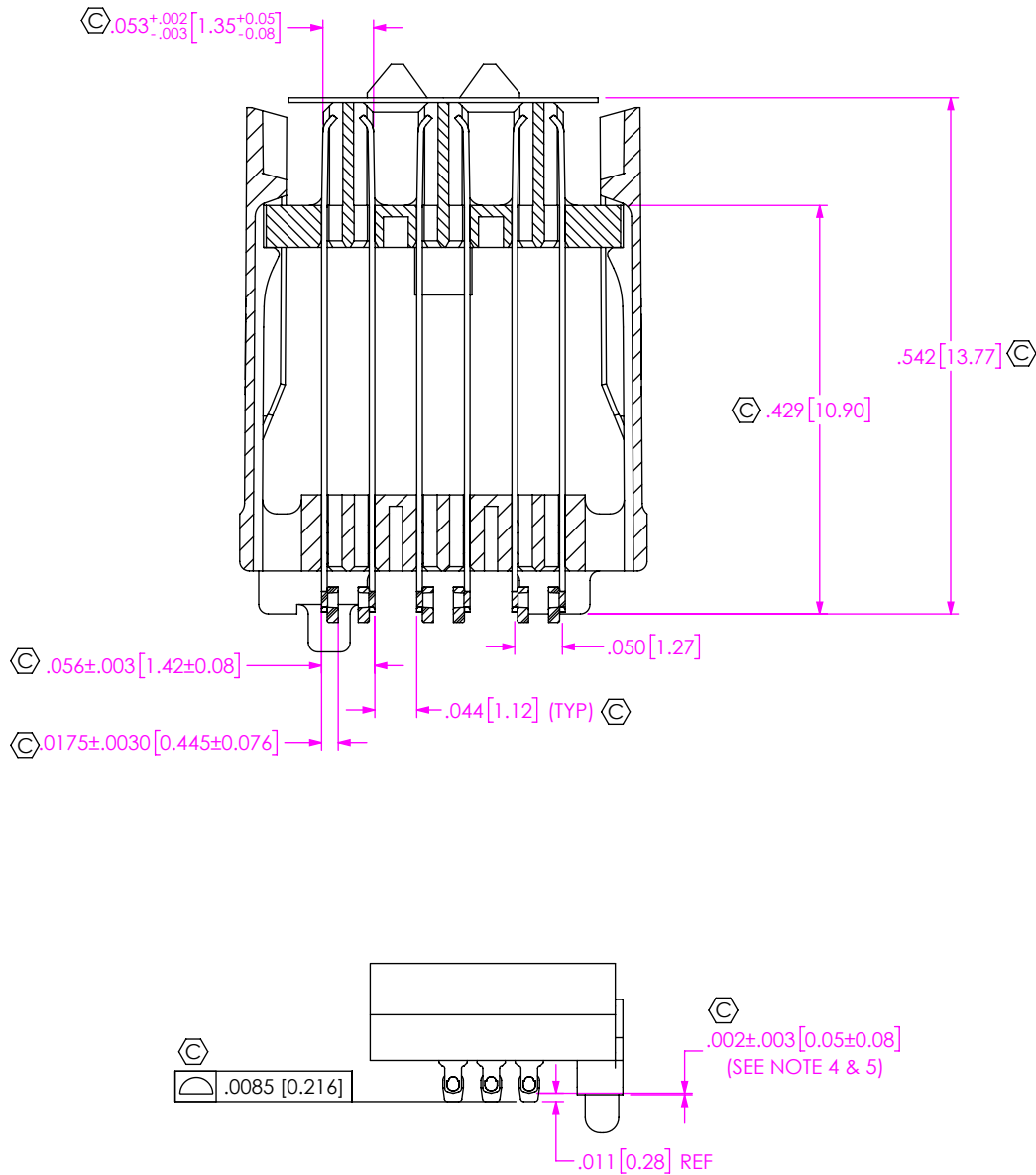

DETAIL 'B'
SCALE 4 : 1

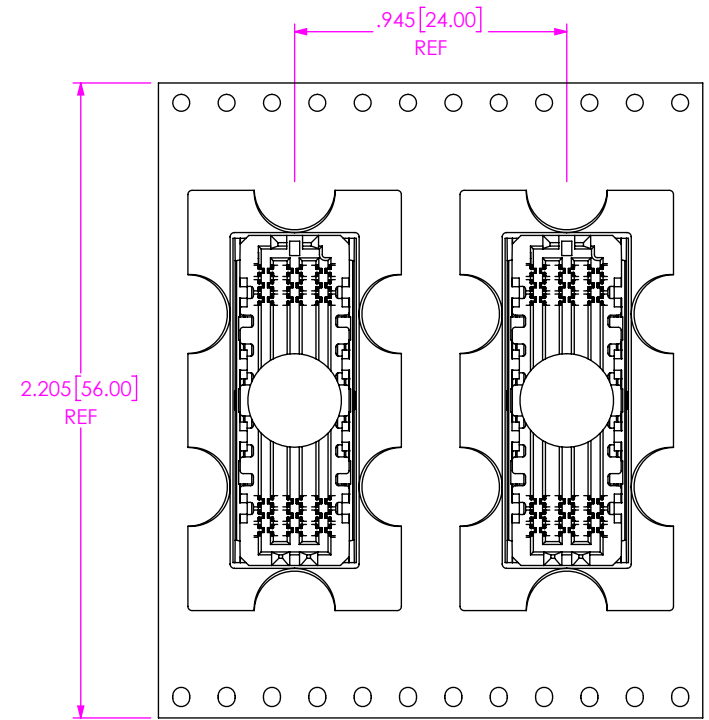

USER DIRECTION OF UN-REELING →
POCKET NOT DETAILED

SECTION "A"-"A"
SCALE 5 : 1

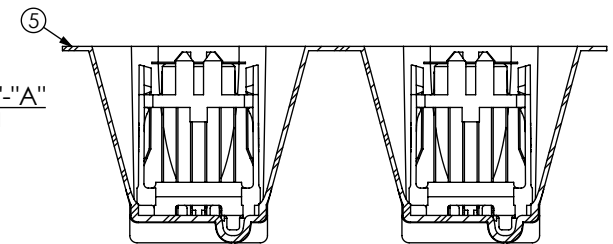

PACKAGING VIEW

PROPRIETARY NOTE
 THIS DOCUMENT CONTAINS CONFIDENTIAL AND PROPRIETARY INFORMATION AND ALL DESIGN, MANUFACTURING, REPRODUCTION, USE, PATENT RIGHTS AND SALES RIGHTS ARE EXPRESSLY RESERVED BY SAMTEC, INC. THIS DOCUMENT SHALL NOT BE DISCLOSED, IN WHOLE OR PART, TO ANY UNAUTHORIZED PERSON OR ENTITY NOR REPRODUCED, TRANSFERRED OR INCORPORATED IN ANY OTHER PRODUCT IN ANY MANNER WITHOUT THE EXPRESS WRITTEN CONSENT OF SAMTEC, INC.



520 PARK EAST BLVD, NEW ALBANY, IN 47150
 PHONE: 812-944-6733 FAX: 812-948-5047
 e-Mail: info@SAMTEC.com code: 55322

SHEET SCALE: 2:1

DESCRIPTION:
VITA 88 MODIFIED 19 POS, 6 ROW .050 TERM ARRAY ASM

DWG. NO.
ASP-212955-01

BY: KEYLIN 09/23/2019 SHEET 2 OF 3

