

Zener Diodes



SMA (DO-214AC)

ADDITIONAL RESOURCES

[3D Models](#)

PRIMARY CHARACTERISTICS		
PARAMETER	VALUE	UNIT
V _Z range nom.	10 to 270	V
Test current I _{ZT}	2 to 50	mA
V _{BR}	9.8 to 264	V
V _{WM}	8.2 to 220	V
P _{PPM}	300	W
T _J max.	150	°C
V _Z specification	Pulse current	
Circuit configuration	Single	
Polarity	Uni-directional	

ORDERING INFORMATION			
DEVICE NAME	ORDERING CODE	TAPED UNITS PER REEL	MINIMUM ORDER QUANTITY
BZG03B-M-series	BZG03Bxxx-M3-08	1500 (7" reel)	6000/box
BZG03B-M-series	BZG03Bxxx-M3-18	6000 (13" reel)	6000/box
BZG03B-M-series	BZG03Bxxx-HM3-08	1500 (7" reel)	6000/box
BZG03B-M-series	BZG03Bxxx-HM3-18	6000 (13" reel)	6000/box

PACKAGE				
PACKAGE NAME	WEIGHT	MOLDING COMPOUND FLAMMABILITY RATING	MOISTURE SENSITIVITY LEVEL	SOLDERING CONDITIONS
SMA (DO-214AC)	73 mg	UL 94 V-0	MSL level 1 (according J-STD-020)	Peak temperature max. 260 °C

ABSOLUTE MAXIMUM RATINGS (T _{amb} = 25 °C, unless otherwise specified)				
PARAMETER	TEST CONDITION	SYMBOL	VALUE	UNIT
Power dissipation	R _{thJA} < 25 K/W, T _{amb} = 75 °C	P _{tot}	3000	mW
	R _{thJA} < 100 K/W, T _{amb} = 25 °C	P _{tot}	1250	mW
Non repetitive peak surge power dissipation	t _p = 100 μs sq.pulse, T _j = 25 °C prior to surge	P _{ZSM}	600	W
Junction to lead		R _{thJL}	25	K/W
Junction to ambient air	Mounted on epoxy-glass hard tissue, fig. 1a	R _{thJA}	150	K/W
	Mounted on epoxy-glass hard tissue, fig. 1b	R _{thJA}	125	K/W
	Mounted on Al-oxide-ceramic (Al ₂ O ₃), fig. 1b	R _{thJA}	100	K/W
Junction temperature		T _j	150	°C
Storage temperature range		T _{stg}	-65 to +150	°C
Operating temperature range		T _{op}	-65 to +150	°C
Forward voltage (max.)	I _F = 0.5 A	V _F	1.2	V

FEATURES

- High reliability
- Voltage range includes 35 breakdown voltages from 10 V to 270 V with ± 2 % for BZG03B-M-series
- Fits onto 5 mm SMD footpads
- Wave and reflow solderable
- AEC-Q101 qualified available
- Base P/N-M3 - halogen-free, RoHS-compliant, and commercial grade
- Base P/NHM3 - halogen-free, RoHS-compliant, and AEC-Q101 qualified
- Material categorization: for definitions of compliance please see www.vishay.com/doc?99912



RoHS
COMPLIANT
HALOGEN
FREE

APPLICATIONS

- Voltage stabilization



ELECTRICAL CHARACTERISTICS ($T_{amb} = 25\text{ }^{\circ}\text{C}$, unless otherwise specified)										
PART NUMBER	ZENER VOLTAGE RANGE			TEST CURRENT	REVERSE LEAKAGE CURRENT		DYNAMIC RESISTANCE		TEMPERATURE COEFFICIENT OF ZENER VOLTAGE	
	V_Z at I_{ZT1}			I_{ZT1}	I_R at V_R		Z_Z at I_{ZT1}		TK_{VZ} at I_{ZT1}	
	V			mA	μA	V	Ω		%K	
	MIN.	NOM.	MAX.		MAX.		TYP.	MAX.	MIN.	MAX.
BZG03B10-M	9.80	10	10.20	50	10	7.5	2	4	0.05	0.09
BZG03B11-M	10.78	11	11.22	50	4	8.2	4	7	0.05	0.1
BZG03B12-M	11.76	12	12.24	50	3	9.1	4	7	0.05	0.1
BZG03B13-M	12.74	13	13.26	50	2	10	5	10	0.05	0.1
BZG03B15-M	14.70	15	15.30	50	1	11	5	10	0.05	0.1
BZG03B16-M	15.68	16	16.32	25	1	12	6	15	0.06	0.11
BZG03B18-M	17.64	18	18.36	25	1	13	6	15	0.06	0.11
BZG03B20-M	19.60	20	20.40	25	1	15	6	15	0.06	0.11
BZG03B22-M	21.56	22	22.44	25	1	16	6	15	0.06	0.11
BZG03B24-M	23.52	24	24.48	25	1	18	7	15	0.06	0.11
BZG03B27-M	26.46	27	27.54	25	1	20	7	15	0.06	0.11
BZG03B30-M	29.40	30	30.60	25	1	22	8	15	0.06	0.11
BZG03B33-M	32.34	33	33.66	25	1	24	8	15	0.06	0.11
BZG03B36-M	35.28	36	36.72	10	1	27	21	40	0.06	0.11
BZG03B39-M	38.22	39	39.78	10	1	30	21	40	0.06	0.11
BZG03B43-M	42.14	43	43.86	10	1	33	24	45	0.07	0.12
BZG03B47-M	46.06	47	47.94	10	1	36	24	45	0.07	0.12
BZG03B51-M	49.98	51	52.02	10	1	39	25	60	0.07	0.12
BZG03B56-M	54.88	56	57.12	10	1	43	25	60	0.07	0.12
BZG03B62-M	60.76	62	63.24	10	1	47	25	80	0.08	0.13
BZG03B68-M	66.64	68	69.36	10	1	51	25	80	0.08	0.13
BZG03B75-M	73.50	75	76.50	10	1	56	30	100	0.08	0.13
BZG03B82-M	80.36	82	83.64	10	1	62	30	100	0.08	0.13
BZG03B91-M	89.18	91	92.82	5	1	68	60	200	0.09	0.13
BZG03B100-M	98.00	100	102.00	5	1	75	60	200	0.09	0.13
BZG03B110-M	107.80	110	112.20	5	1	82	80	250	0.09	0.13
BZG03B120-M	117.60	120	122.40	5	1	91	80	250	0.09	0.13
BZG03B130-M	127.40	130	132.60	5	1	100	110	300	0.09	0.13
BZG03B150-M	147.00	150	153.00	5	1	110	130	300	0.09	0.13
BZG03B160-M	156.80	160	163.20	5	1	120	150	350	0.09	0.13
BZG03B180-M	176.40	180	183.60	5	1	130	180	400	0.09	0.13
BZG03B200-M	196.00	200	204.00	5	1	150	200	500	0.09	0.13
BZG03B220-M	215.60	220	224.40	2	1	160	350	750	0.09	0.13
BZG03B240-M	235.20	240	244.80	2	1	180	400	850	0.09	0.13
BZG03B270-M	264.60	270	275.40	2	1	200	450	1000	0.09	0.13

BASIC CHARACTERISTICS ($T_{amb} = 25\text{ }^{\circ}\text{C}$, unless otherwise specified)

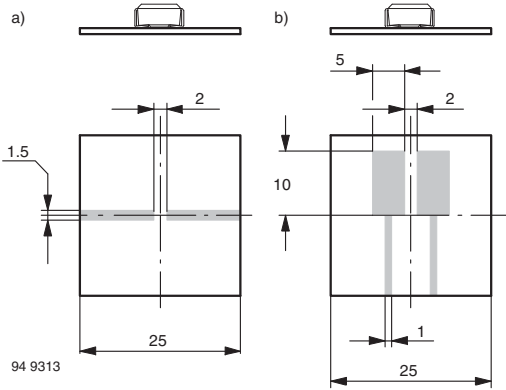

Fig. 1 - Boards for R_{thJA} Definition (Copper Overlay 35 μ)

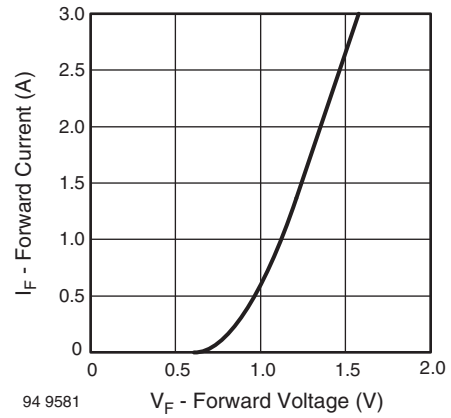

Fig. 3 - Forward Current vs. Forward Voltage

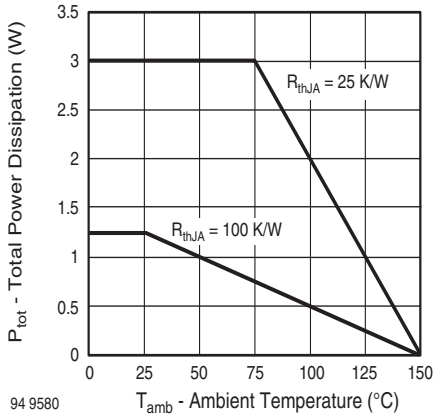

Fig. 2 - Total Power Dissipation vs. Ambient Temperature

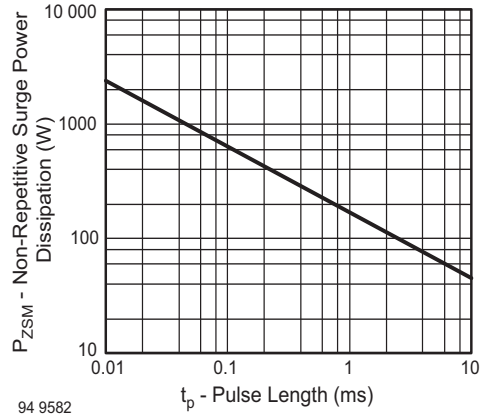

Fig. 4 - Non Repetitive Surge Power Dissipation vs. Pulse Length

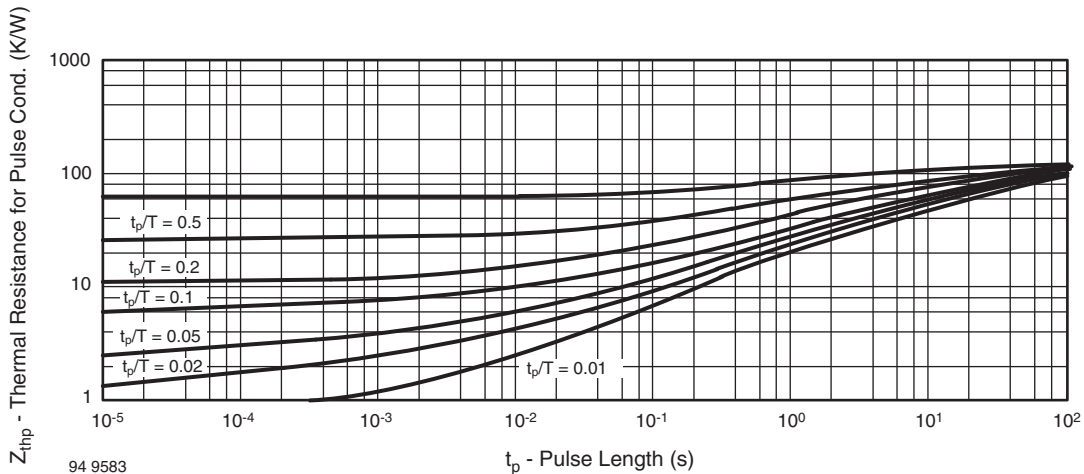
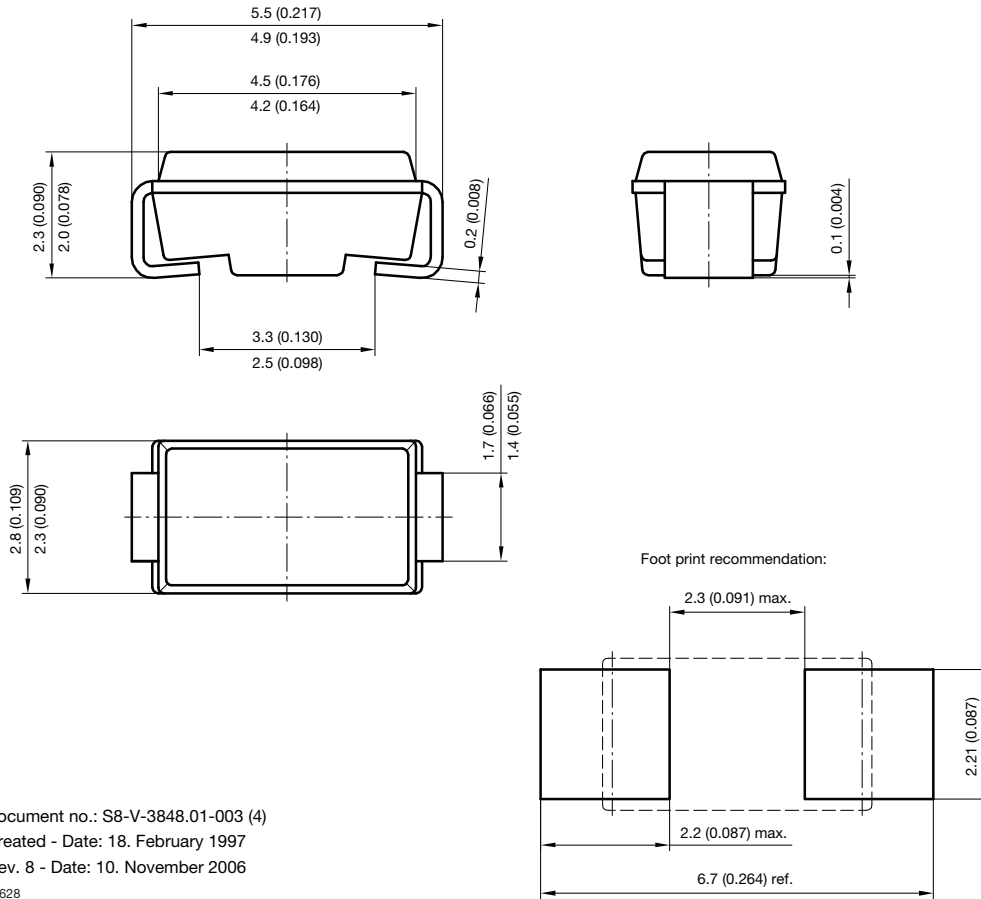

Fig. 5 - Thermal Response



PACKAGE DIMENSIONS in millimeters (inches): **SMA (DO-214AC)**



Document no.: S8-V-3848.01-003 (4)
 Created - Date: 18. February 1997
 Rev. 8 - Date: 10. November 2006
 19628



Disclaimer

ALL PRODUCT, PRODUCT SPECIFICATIONS AND DATA ARE SUBJECT TO CHANGE WITHOUT NOTICE TO IMPROVE RELIABILITY, FUNCTION OR DESIGN OR OTHERWISE.

Vishay Intertechnology, Inc., its affiliates, agents, and employees, and all persons acting on its or their behalf (collectively, "Vishay"), disclaim any and all liability for any errors, inaccuracies or incompleteness contained in any datasheet or in any other disclosure relating to any product.

Vishay makes no warranty, representation or guarantee regarding the suitability of the products for any particular purpose or the continuing production of any product. To the maximum extent permitted by applicable law, Vishay disclaims (i) any and all liability arising out of the application or use of any product, (ii) any and all liability, including without limitation special, consequential or incidental damages, and (iii) any and all implied warranties, including warranties of fitness for particular purpose, non-infringement and merchantability.

Statements regarding the suitability of products for certain types of applications are based on Vishay's knowledge of typical requirements that are often placed on Vishay products in generic applications. Such statements are not binding statements about the suitability of products for a particular application. It is the customer's responsibility to validate that a particular product with the properties described in the product specification is suitable for use in a particular application. Parameters provided in datasheets and / or specifications may vary in different applications and performance may vary over time. All operating parameters, including typical parameters, must be validated for each customer application by the customer's technical experts. Product specifications do not expand or otherwise modify Vishay's terms and conditions of purchase, including but not limited to the warranty expressed therein.

Except as expressly indicated in writing, Vishay products are not designed for use in medical, life-saving, or life-sustaining applications or for any other application in which the failure of the Vishay product could result in personal injury or death. Customers using or selling Vishay products not expressly indicated for use in such applications do so at their own risk. Please contact authorized Vishay personnel to obtain written terms and conditions regarding products designed for such applications.

No license, express or implied, by estoppel or otherwise, to any intellectual property rights is granted by this document or by any conduct of Vishay. Product names and markings noted herein may be trademarks of their respective owners.