

## Features and Application

MIL-DTL-38999 Series II connectors feature a bayonet coupling mechanism with lower profile design and rear-removable crimp contact retention system.

These connectors were designed for military and commercial applications where the prime requirements are lower profile and lighter weight.

Reduction of both size and weight were achieved through the use of thinner shell walls and length restrictions. These design restrictions reduced the RFI attenuation characteristics and the “scoop” protection, while yielding an excellent general purpose, lightweight connector. Compared to Series I, Series II connectors achieve up to 20% reduction in mated pair length, up to 39% reduction in outside diameter and up to 40% reduction in weight (128 pin mated pair).

This family of connectors is offered in six receptacle-mounting styles. They include square flange receptacles, for both front and rear panel (wall) mounting; square flange receptacles, for both front and rear panel (box) mounting; square flange receptacle with extended grommet, for front of panel (box) mounting; and jam nut receptacles which incorporate “O” ring seals, designed for rear panel “D” hole mounting.

Plugs are available in two designs, with and without RFI grounding.

Fifty-two insert arrangement per MIL-STD-1560 are tooled and qualified to MIL-DTL-38999 Series II, utilizing 3 to 128 M39029 contacts. Contacts come in sizes 22D, 22M, 22, 20, 16 and 12, terminating wire sizes from 28 to 12 gauge.

These connectors are available in wide range of shell materials and finishes. Aluminum shells are offered in electroless nickel, bright cadmium, anodized, and olive drab cadmium. Other finishes such as zinc nickel are available upon request to commercial callouts only. In addition, we offer passivated stainless steel shells with standard environment-resisting inserts (commercial callouts only).

**Universal I/R Tool** – A single, expendable plastic tool is used for both insertion and removal of contacts.

**Closed-Entry Socket Insert** – Hard dielectric socket face has lead-in chamfers for positive alignment of pins (even partially bent within pre-established limits) with sockets.

**Interfacial Pin Insert Seal** – Raised moisture barriers around each pin, which mate into lead-in chamfers of hard face socket insert, provide individual contact sealing. Interfacial seal is never touched by service tools.

**Elastomer Wire Sealing Grommet** – Sealing over a wide range of wire diameters is assured by a triple wire seal in each cavity at the rear of the connector.

**Superior Contact Stability** – Rear release crimp contact system features a stamped beryllium-copper retaining clip captivated by molded-in shoulders of each contact cavity in the insulator. A rear-inserted M81969 plastic tool expands the tines beyond the shoulder, releasing the contact.

**Shell Polarization** – Alternate key/keyway positions prevent cross mating of adjacent connectors having same insert arrangement.





## Performance Specifications

### Operating Temperature Range

Finish B: -65°C to +175°C (-85°F to +347°F)  
 Finishes C and F: -65°C to +200°C (-85°F to +392°F)  
 Finish A: -65°C to +150°C (-85°F to 302°F)

### Material and Plating Data (Finish)

B – aluminum shell, olive drab cadmium over nickel base  
 C – aluminum shell, black anodized finish  
 F – aluminum shell, electroless nickel finish  
 A – aluminum shell, silver to light iridescent yellow color (bright) cadmium over electroless nickel base

### Corrosion Resistance

Finishes A, B and C withstand 500-hour salt spray.  
 Finish F withstands 48-hour salt spray.

### Durability

Mated connectors withstand a minimum of 250 mating cycles for RFI plug (MS27484) and 500 cycles for MS27473 and MS27500 plugs.

### Environmental Seal

Wired, mated connectors with specified accessories attached, shall meet the altitude-immersion test specified by MIL-DTL-38999.

### Fluid Resistance

Connectors resist specified immersions in MIL-PRF-7808, MIL-PRF-23699, MIL-PRF-5606, M2-V Chevron oil, Coolanol 25, MIL-DTL-83133 (JP-8), MIL-DTL-5624 (JP-4, JP-5), SAE-AMS1424 Type I, and other solvents and cleaning agents.

### Voltage Rating

Service Rating	Suggested Operating Voltage		Test Voltage	Test Voltage	Test Voltage	Test Voltage
	(Sea Level)		Sea Level	50,000 Ft.	70,000 Ft.	100,000 Ft.
	AC (RMS)	DC	V RMS	V RMS	V RMS	V RMS
M	400	550	1300	550	350	200
N	300	450	1000	400	260	200
I	600	850	1800	600	400	200
II	900	1250	2300	800	500	200

**Note:** The establishment of electrical safety factors is left entirely to the designer, as he is in the best position to know

### Shell-to-Shell Conductivity

Maximum potential drop shall not exceed:

- With RFI spring fingers, finish F = 1.0 millivolt, while finishes A and B = 2.5 millivolts.
- Without spring fingers = 200 millivolts.
- Finish C = nonconductive.

### Shielding Effectiveness

RFI and EMI attenuation at the specified frequencies meet the requirements of MIL-DTL-38999.

- RFI shielding effectiveness of mated connectors with RFI backshells is measured in a triaxial radio frequency leakage fixture.
- EMI shielding effectiveness is measured at the interface of mated connectors and tested by the mode-stirred technique specified in method 3008 of MIL-STD-1344.

### Shock and Vibration Requirements

Wired, mated connectors shall not be damaged, nor shall there be a current interruption longer than one microsecond when subjected to the following:

### Standard Shock

Mated connectors withstand a pulse of approximate half sine wave of 300 G magnitude with duration of three milliseconds applied in three axes per MIL-STD-1344, method 2004.

### Vibration

Mated connectors withstand the following vibration levels:

- Random vibration per MIL-STD-1344, method 205 test condition VI, Letter “J”.

exactly what peak voltages, switching currents, transients, etc., can be expected in a particular circuit.

**MIL-DTL-38999**  
**Part Number Development**  
**Series II**



Military and Aero-Electric Part Number Development

Mil. Prefix	MS	27473	T	12	B	35	P	A	
Aero Prefix	AE	273	T	12	B	35	P	A	-340
<b>Shell Type</b>									
27472 = Front, wall mount receptacle = <b>272</b> (Aero p/n)									
27473 = Straight plug = <b>273</b> (Aero p/n)									
27474 = Jam nut receptacle = <b>274</b> (Aero p/n)									
27484 = RFI grounding plug = <b>284</b> (Aero p/n)									
27497 = Rear, wall mount receptacle = <b>297</b> (Aero p/n)									
27499 = Front, box mount receptacle = <b>299</b> (Aero p/n)									
27500 = Standard plug with 90° backshell = <b>200</b> (Aero p/n)									
27508 = Rear, box mount receptacle = <b>208</b> (Aero p/n)									
27513 = Front, box mount rec. (long grommet) = <b>213</b> (Aero p/n)									
<b>Class</b>									
T = With accessory thread (MS27472, 27473, 27474, 27484 & 27497)									
E = Same as T in line above except connector is kitted with E-Nut = No accessory thread, box mount (MS27499 & MS27508) = No accessory thread, box mount, long grommet (MS27513)									
P = Supplied with ring and potting boot (same shell types as "T" class)									
<b>Shell Size</b>									
8, 10, 12, 14, 16, 18, 20, 22 or 24									
<b>Finish (Material &amp; Plating)</b>									
A = Aluminum shell, silver to light iridescent yellow (bright) cadmium over electroless nickel base									
B = Aluminum shell, olive drab cadmium over electroless nickel base									
C = Aluminum shell, black anodized finish (not available in MS27484)									
F = Aluminum shell, electroless nickel finish									
E = Stainless steel shell, passivated (Aero p/n only, n/a in AE284)									
<b>Insert Arrangement</b>									
See page 15 thru 19									
<b>Contact Designator</b>									
P = Pin      A = Pin connector less pins (with intent to use non-std pin contacts)									
S = Socket    B = Socket connector less sockets (with intent to use non-std socket contacts)									
<b>Polarization (Keying)</b>									
N = Normal (Omitted in part number)									
A, B, C, or D (B & C keyways are not available in shell size 8)									
<b>Modification (applies to Aero part numbers only)</b>									
01 = Less contacts (is not marked on the part)									
340 = Connector kitted with M85049/27-XXX E-nut									
341 = Connector kitted with M85049/49-2-XXX straight clamp									
342 = Connector kitted with M85049/47XXX right angle clamp									
Consult factory for other modifications									

**Note 1:** Each connector is furnished with contacts unless ordered less contacts (L/C) as follows: One spare contact for inserts requiring 2 through 26 of each contact and two spares for inserts with 27 or more contacts, and a minimum of one sealing plug up to 10% of the number contacts. One insertion/extraction tool for each contact size is also included.

**Note 2:** Proper part number marking has no "0" in front of single digit shell size (8) and no "0" in front of single digit layout. Example of each: J MS27472T8B35S and J MS27472T10B5S. In both "N" for normal is omitted. Please note that JAN or J marking is required immediately in front of MS number.

Bayonet Coupling, Crimp Removable, Rear Release, Low Profile/Light Weight

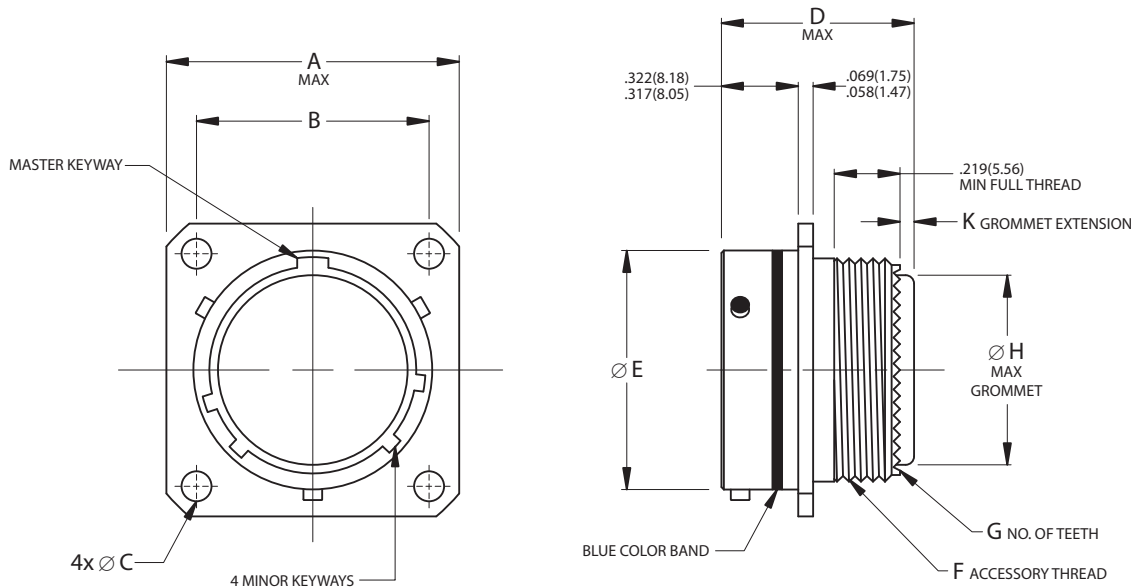

MIL-DTL-38999 S II

Page 22 Completed Part Number  
 Page 34 Contacts, Sealing Plugs and Tools  
 Pages 17-19 Insert Arrangements  
 Page 21 Performance Specifications  
 Pages 15, 16 Insert Availability and Contact Information  
 Page 32 Polarization

Shell Size	A		B		Ø C		D		Ø E		F	G	Ø H		K	
	Maximum		(TP)		+0.010	+0.25	Maximum		±.003	±.08	Accessory Thread	No. of Teeth	Maximum		Grommet Extension	
	inch	mm	inch	mm	inch	mm	inch	mm	inch	mm	UNEF-2A		inch	mm	inch	mm
8	.828	21.03	.594	15.09	.120	3.05	.932	23.67	.471	11.96	7/16-28	12	.299	7.59	.150/.090	3.81/2.29
10	.954	24.23	.719	18.26	.120	3.05	.932	23.67	.588	14.94	9/16-24	16	.427	10.85	.150/.090	3.81/2.29
12	1.047	26.59	.812	20.62	.120	3.05	.932	23.67	.748	19.00	11/16-24	20	.541	13.74	.150/.090	3.81/2.29
14	1.141	28.98	.906	23.01	.120	3.05	.932	23.67	.873	22.17	13/16-20	24	.666	16.92	.150/.090	3.81/2.29
16	1.234	31.34	.969	24.61	.120	3.05	.932	23.67	.998	25.35	15/16-20	28	.791	20.09	.150/.090	3.81/2.29
18	1.328	33.73	1.062	26.97	.120	3.05	.932	23.67	1.123	28.52	1-1/16-18	32	.897	22.78	.150/.090	3.81/2.29
20	1.453	36.91	1.156	29.36	.120	3.05	.932	23.67	1.248	31.70	1-3/16-18	36	1.022	25.96	.150/.090	3.81/2.29
22	1.578	40.08	1.250	31.75	.120	3.05	.932	23.67	1.373	34.87	1-5/16-18	40	1.147	29.13	.150/.090	3.81/2.29
24	1.703	43.26	1.375	34.93	.147	3.73	1.000	25.40	1.498	38.05	1-7/16-18	44	1.272	32.31	.140/.040	3.56/1.02

**MS27497**  
**Rear, Wall Mounting Receptacle**  
**AE297**



Bayonet Coupling, Crimp Removable, Rear Release, Low Profile/Light Weight

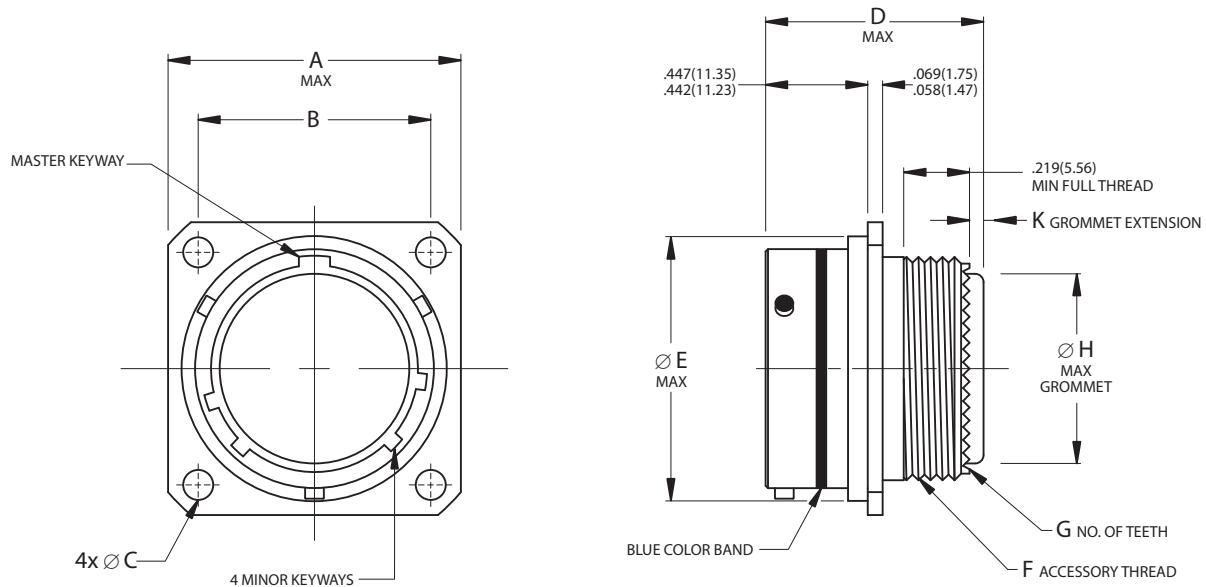

Page 22	Completed Part Number
Page 34	Contacts, Sealing Plugs and Tools
Pages 17-19	Insert Arrangements
Page 21	Performance Specifications
Pages 15, 16	Insert Availability and Contact Information
Page 32	Polarization

**Note:** See page 33 for panel thickness.

Shell Size	A		B		Ø C		D		Ø E		F	G	Ø H		K	
	Maximum		(TP)		+0.010	+0.25	Maximum		Maximum		Accessory Thread	No. of Teeth	Maximum		Grommet Extension	
	inch	mm	inch	mm	inch	mm	inch	mm	inch	mm	UNEF-2A		inch	mm	inch	mm
8	.828	21.03	.594	15.09	.120	3.05	.988	25.10	.547	13.89	7/16-28	12	.299	7.59	.150/.090	3.81/2.29
10	.954	24.23	.719	18.26	.120	3.05	.988	25.10	.672	17.07	9/16-24	16	.427	10.85	.150/.090	3.81/2.29
12	1.047	26.59	.812	20.62	.120	3.05	.988	25.10	.844	21.44	11/16-24	20	.541	13.74	.150/.090	3.81/2.29
14	1.141	28.98	.906	23.01	.120	3.05	.988	25.10	.969	24.61	13/16-20	24	.666	16.92	.150/.090	3.81/2.29
16	1.234	31.34	.969	24.61	.120	3.05	.988	25.10	1.094	27.79	15/16-20	28	.791	20.09	.150/.090	3.81/2.29
18	1.328	33.73	1.062	26.97	.120	3.05	.988	25.10	1.219	30.96	1-1/16-18	32	.897	22.78	.150/.090	3.81/2.29
20	1.453	36.91	1.156	29.36	.120	3.05	.988	25.10	1.344	34.14	1-3/16-18	36	1.022	25.96	.150/.090	3.81/2.29
22	1.578	40.08	1.250	31.75	.120	3.05	.988	25.10	1.469	37.31	1-5/16-18	40	1.147	29.13	.150/.090	3.81/2.29
24	1.703	43.26	1.375	34.93	.147	3.73	1.056	26.82	1.594	40.49	1-7/16-18	44	1.272	32.31	.140/.040	3.56/1.02

MIL-DTL-38999 S II

Bayonet Coupling, Crimp Removable, Rear Release, Low Profile/Light Weight

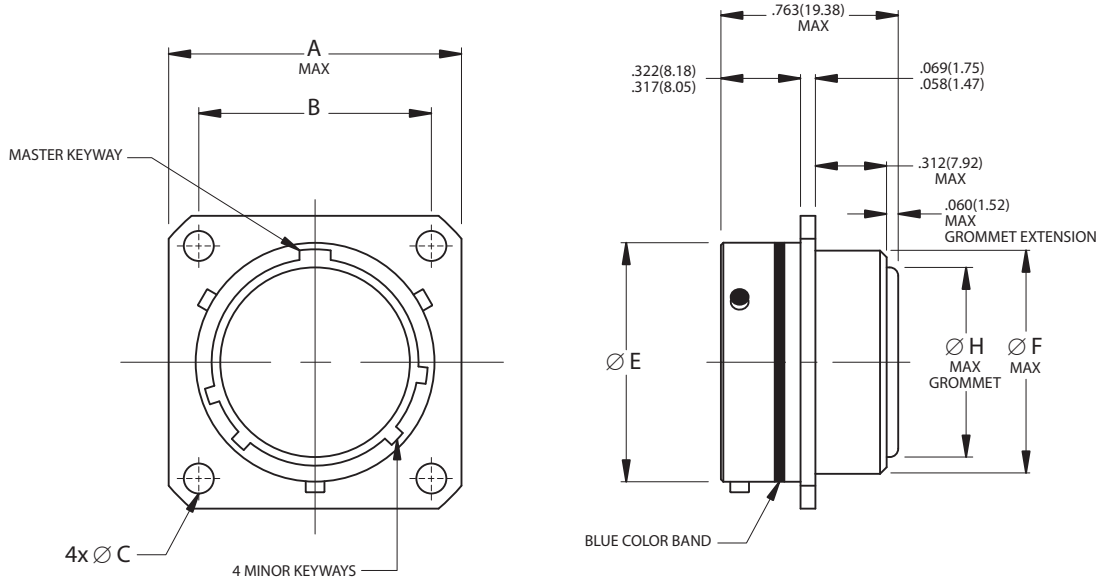

Page 22	Completed Part Number
Page 34	Contacts, Sealing Plugs and Tools
Pages 17-19	Insert Arrangements
Page 21	Performance Specifications
Pages 15, 16	Insert Availability and Contact Information
Page 32	Polarization

Shell Size	A		B		Ø C		Ø E		Ø F		Ø H	
	Maximum		(TP)		+0.010	+0.25	±0.003	±0.08	Maximum		Maximum	
	inch	mm	inch	mm	inch	mm	inch	mm	inch	mm	inch	mm
8	.828	21.03	.594	15.09	.120	3.05	.471	11.96	.453	11.51	.299	7.59
10	.954	24.23	.719	18.26	.120	3.05	.588	14.94	.578	14.68	.427	10.85
12	1.047	26.59	.812	20.62	.120	3.05	.748	19.00	.703	17.86	.541	13.74
14	1.141	28.98	.906	23.01	.120	3.05	.873	22.17	.828	21.03	.666	16.92
16	1.234	31.34	.969	24.61	.120	3.05	.998	25.35	.953	24.21	.791	20.09
18	1.328	33.73	1.062	26.97	.120	3.05	1.123	28.52	1.062	26.97	.897	22.78
20	1.453	36.91	1.156	29.36	.120	3.05	1.248	31.70	1.188	30.18	1.022	25.96
22	1.578	40.08	1.250	31.75	.120	3.05	1.373	34.87	1.312	33.32	1.147	29.13
24	1.703	43.26	1.375	34.93	.147	3.73	1.498	38.05	1.438	36.53	1.272	32.31

**MS27508**  
**Rear, Box Mounting Receptacle**  
**AE208**



Bayonet Coupling, Crimp Removable, Rear Release, Low Profile/Light Weight

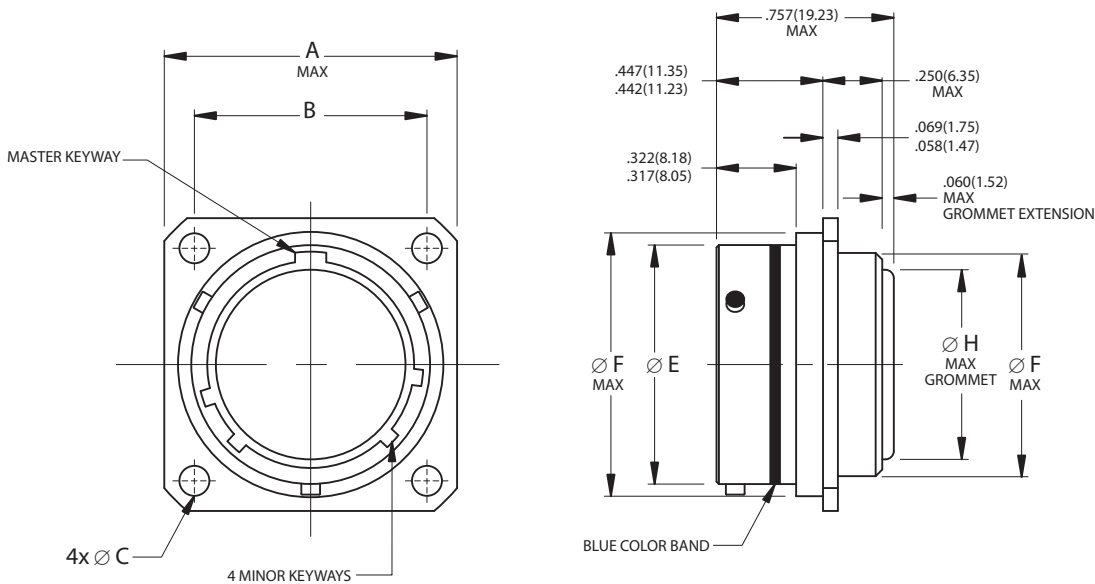

MIL-DTL-38999 S II

- Page 22 Completed Part Number
- Page 34 Contacts, Sealing Plugs and Tools
- Pages 17-19 Insert Arrangements
- Page 21 Performance Specifications
- Pages 15, 16 Insert Availability and Contact Information
- Page 32 Polarization

**Note:** See page 33 for panel thickness.

Shell Size	A		B		∅ C		∅ E		∅ F		∅ H	
	Maximum		(TP)		+0.01	+0.25	±0.003	±0.08	Maximum		Maximum	
	inch	mm	inch	mm	inch	mm	inch	mm	inch	mm	inch	mm
8	.828	21.03	.594	15.09	.120	3.05	.471	11.96	.547	13.89	.299	7.59
10	.954	24.23	.719	18.26	.120	3.05	.588	14.94	.672	17.07	.427	10.85
12	1.047	26.59	.812	20.62	.120	3.05	.748	19.00	.844	21.44	.541	13.74
14	1.141	28.98	.906	23.01	.120	3.05	.873	22.17	.969	24.61	.666	16.92
16	1.234	31.34	.969	24.61	.120	3.05	.998	25.35	1.094	27.79	.791	20.09
18	1.328	33.73	1.062	26.97	.120	3.05	1.123	28.52	1.219	30.96	.897	22.78
20	1.453	36.91	1.156	29.36	.120	3.05	1.248	31.70	1.344	34.14	1.022	25.96
22	1.578	40.08	1.250	31.75	.120	3.05	1.373	34.87	1.469	37.31	1.147	29.13
24	1.703	43.26	1.375	34.93	.147	3.73	1.498	38.05	1.594	40.49	1.272	32.31



**MS27513**  
**Long Grommet, Front, Box Mount Receptacle**  
**AE213**

Bayonet Coupling, Crimp Removable, Rear Release, Low Profile/Light Weight

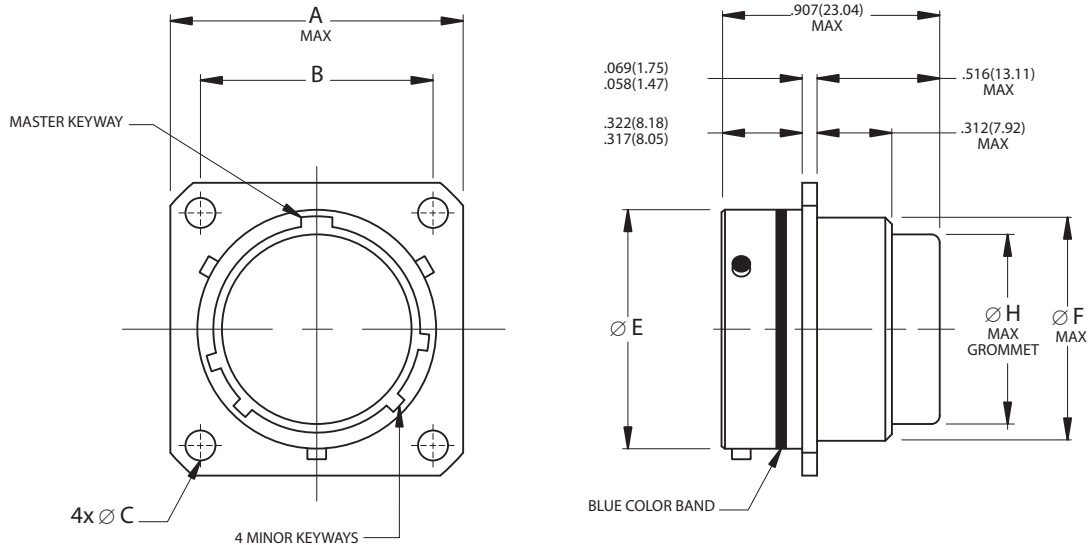

MIL-DTL-38999 S II

- Page 22 Completed Part Number
- Page 34 Contacts, Sealing Plugs and Tools
- Pages 17-19 Insert Arrangements
- Page 21 Performance Specifications
- Pages 15, 16 Insert Availability and Contact Information
- Page 32 Polarization

Shell Size	A		B		Ø C		Ø E		Ø F		Ø H	
	Maximum		(TP)		+0.010	+0.25	±.003	±.08	Maximum		Maximum	
	inch	mm	inch	mm	inch	mm	inch	mm	inch	mm	inch	mm
8	.828	21.03	.594	15.09	.120	3.05	.471	11.96	.453	11.51	.299	7.59
10	.954	24.23	.719	18.26	.120	3.05	.588	14.94	.578	14.68	.427	10.85
12	1.047	26.59	.812	20.62	.120	3.05	.748	19.00	.703	17.86	.541	13.74
14	1.141	28.98	.906	23.01	.120	3.05	.873	22.17	.828	21.03	.666	16.92
16	1.234	31.34	.969	24.61	.120	3.05	.998	25.35	.953	24.21	.791	20.09
18	1.328	33.73	1.062	26.97	.120	3.05	1.123	28.52	1.062	26.97	.897	22.78
20	1.453	36.91	1.156	29.36	.120	3.05	1.248	31.70	1.188	30.18	1.022	25.96
22	1.578	40.08	1.250	31.75	.120	3.05	1.373	34.87	1.312	33.32	1.147	29.13
24	1.703	43.26	1.375	34.93	.147	3.73	1.498	38.05	1.438	36.53	1.272	32.31

**MS27474**  
**Jam Nut Receptacle**  
**AE274**



Bayonet Coupling, Crimp Removable, Rear Release, Low Profile/Light Weight

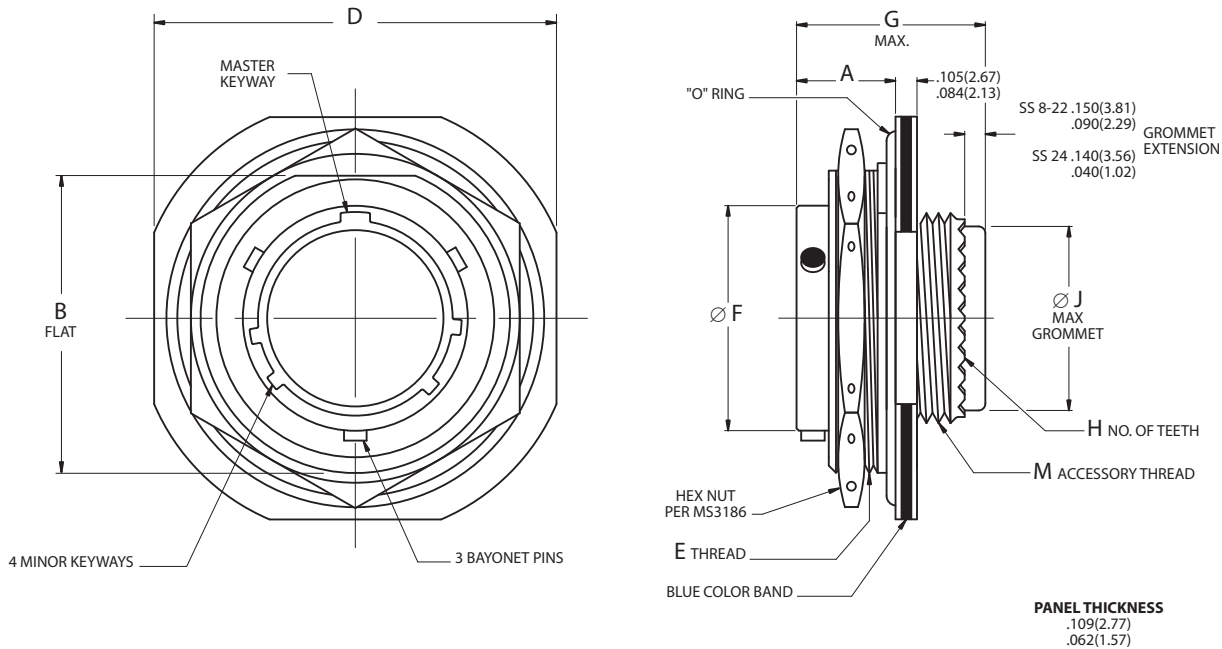

**PANEL THICKNESS**  
 .109(2.77)  
 .062(1.57)

- Page 22 Completed Part Number
- Page 34 Contacts, Sealing Plugs and Tools
- Pages 17-19 Insert Arrangements
- Page 21 Performance Specifications
- Pages 15, 16 Insert Availability and Contact Information
- Page 32 Polarization

Shell Size	A		B		D		E	Ø F		G		H	Ø J		M
	±.005	±.13	+0.001	+0.03	±.016	±.41		±.003	±.08	Maximum	No. of Teeth		Maximum	Accessory Thread	
	inch	mm	inch	mm	inch	mm		inch	mm	inch	mm		inch	mm	
8	.438	11.13	.817	20.75	1.250	31.75	7/8-20UNEF	.471	11.96	.937	23.80	12	.299	7.59	7/16-28
10	.438	11.13	.941	23.90	1.375	34.93	1-20UNEF	.588	14.94	.937	23.80	16	.427	10.85	9/16-24
12	.438	11.13	1.065	27.05	1.500	38.10	1-1/8-18UNEF	.748	19.00	.937	23.80	20	.541	13.74	11/16-24
14	.438	11.13	1.190	30.23	1.625	41.28	1-1/4-18UNEF	.873	22.17	.937	23.80	24	.666	16.92	13/16-20
16	.438	11.13	1.320	33.53	1.781	45.24	1-3/8-18UNEF	.998	25.35	.937	23.80	28	.791	20.09	15/16-20
18	.438	11.13	1.440	36.58	1.890	48.01	1-1/2-18UNEF	1.123	28.52	.937	23.80	32	.897	22.78	1-1/16-18
20	.464	11.79	1.565	39.75	2.016	51.21	1-5/8-18UNEF	1.248	31.70	.931	23.65	36	1.022	25.96	1-3/16-18
22	.464	11.79	1.690	42.93	2.140	54.36	1-3/4-18UNS	1.373	34.87	.931	23.65	40	1.147	29.13	1-5/16-18
24	.464	11.79	1.815	46.10	2.265	57.53	1-7/8-16UN	1.498	38.05	.984	24.99	44	1.272	32.31	1-7/16-18

MIL-DTL-38999 S II

Bayonet Coupling, Crimp Removable, Rear Release, Low Profile/Light Weight

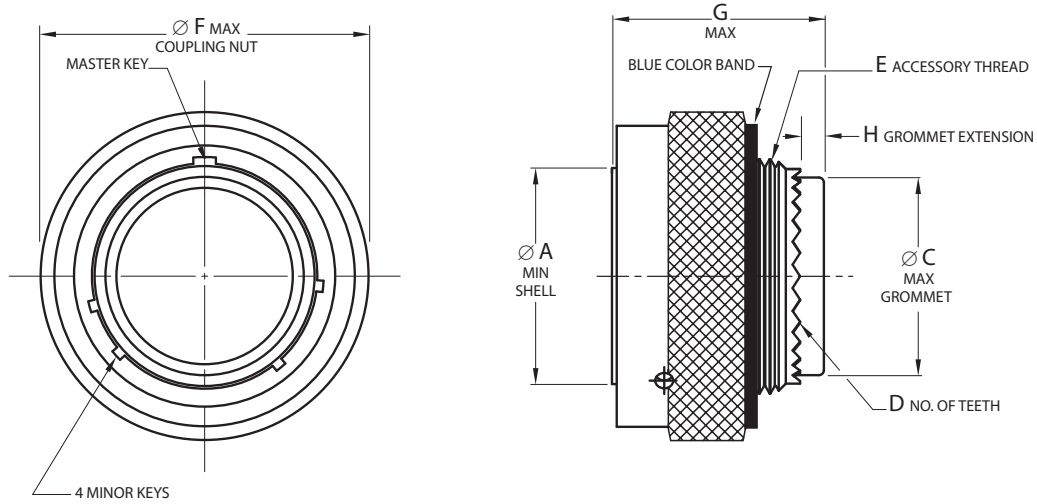

Page 22 Completed Part Number  
 Page 34 Contacts, Sealing Plugs and Tools  
 Pages 17-19 Insert Arrangements  
 Page 21 Performance Specifications  
 Pages 15, 16 Insert Availability and Contact Information  
 Page 32 Polarization

Shell Size	Ø A		Ø C		D	E	Ø F		G		H	
	Minimum	Maximum	Minimum	Maximum	No of Teeth	Accessory Thread	Minimum	Maximum	Minimum	Maximum	Minimum	Maximum
	inch	mm	inch	mm		UNEF-2A	inch	mm	inch	mm	inch	mm
8	.337	8.56	.299	7.59	12	7/16-28	.750	19.05	.916	23.27	.150/.090	3.81/2.29
10	.465	11.81	.427	10.85	16	9/16-24	.859	21.82	.916	23.27	.150/.090	3.81/2.29
12	.557	14.15	.541	13.74	20	11/16-24	1.031	26.19	.916	23.27	.150/.090	3.81/2.29
14	.702	17.83	.666	16.92	24	13/16-20	1.156	29.36	.916	23.27	.150/.090	3.81/2.29
16	.827	21.01	.791	20.09	28	15/16-20	1.281	32.54	.916	23.27	.150/.090	3.81/2.29
18	.927	23.55	.897	22.78	32	1-1/16-18	1.406	35.71	.916	23.27	.150/.090	3.81/2.29
20	1.052	26.72	1.022	25.96	36	1-3/16-18	1.531	38.89	.916	23.27	.150/.090	3.81/2.29
22	1.177	29.90	1.147	29.13	40	1-5/16-18	1.641	41.68	.916	23.27	.150/.090	3.81/2.29
24	1.302	33.07	1.272	32.31	44	1-7/16-18	1.766	44.86	.984	24.99	.140/.040	3.56/1.02

**MS27484**  
**RFI Grounding Plug**  
**AE284**



Bayonet Coupling, Crimp Removable, Rear Release, Low Profile/Light Weight

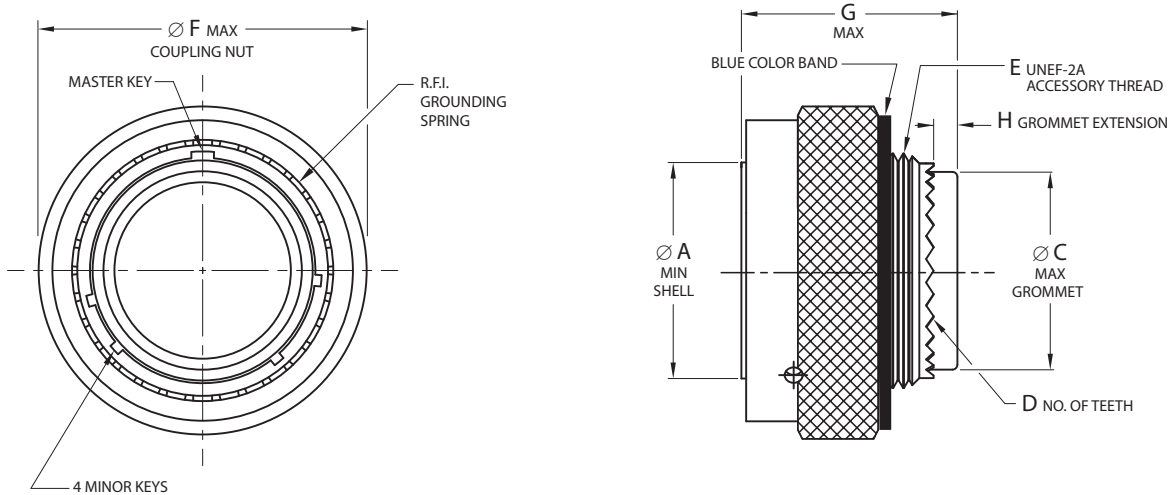

Page 22	Completed Part Number
Page 34	Contacts, Sealing Plugs and Tools
Pages 17-19	Insert Arrangements
Page 21	Performance Specifications
Pages 15, 16	Insert Availability and Contact Information
Page 32	Polarization

Shell Size	Ø A		Ø C		D	E	Ø F		G		H	
	Minimum		Maximum				No of Teeth	Accessory Thread	Maximum		Maximum	
	inch	mm	inch	mm	UNEF-2A	inch			mm	inch	mm	inch
8	.337	<b>8.56</b>	.299	<b>7.59</b>	12	7/16-28	.750	<b>19.05</b>	.916	<b>23.27</b>	.150/.090	<b>3.81/2.29</b>
10	.465	<b>11.81</b>	.427	<b>10.85</b>	16	9/16-24	.859	<b>21.82</b>	.916	<b>23.27</b>	.150/.090	<b>3.81/2.29</b>
12	.557	<b>14.15</b>	.541	<b>13.74</b>	20	11/16-24	1.031	<b>26.19</b>	.916	<b>23.27</b>	.150/.090	<b>3.81/2.29</b>
14	.702	<b>17.83</b>	.666	<b>16.92</b>	24	13/16-20	1.156	<b>29.36</b>	.916	<b>23.27</b>	.150/.090	<b>3.81/2.29</b>
16	.827	<b>21.01</b>	.791	<b>20.09</b>	28	15/16-20	1.281	<b>32.54</b>	.916	<b>23.27</b>	.150/.090	<b>3.81/2.29</b>
18	.927	<b>23.55</b>	.897	<b>22.78</b>	32	1-1/16-18	1.406	<b>35.71</b>	.916	<b>23.27</b>	.150/.090	<b>3.81/2.29</b>
20	1.052	<b>26.72</b>	1.022	<b>25.96</b>	36	1-3/16-18	1.531	<b>38.89</b>	.916	<b>23.27</b>	.150/.090	<b>3.81/2.29</b>
22	1.177	<b>29.90</b>	1.147	<b>29.13</b>	40	1-5/16-18	1.641	<b>41.68</b>	.916	<b>23.27</b>	.150/.090	<b>3.81/2.29</b>
24	1.302	<b>33.07</b>	1.272	<b>32.31</b>	44	1-7/16-18	1.766	<b>44.86</b>	.984	<b>24.99</b>	.140/.040	<b>3.56/1.02</b>

MIL-DTL-38999 S II

Bayonet Coupling, Crimp Removable, Rear Release, Low Profile/Light Weight

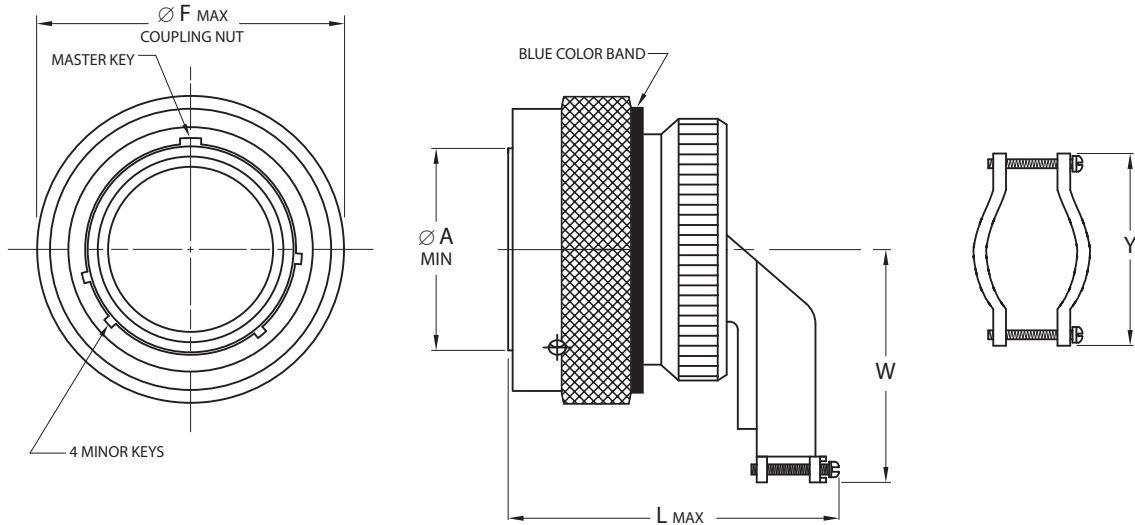

Page 22	Completed Part Number
Page 34	Contacts, Sealing Plugs and Tools
Pages 17-19	Insert Arrangements
Page 21	Performance Specifications
Pages 15, 16	Insert Availability and Contact Information
Page 32	Polarization

Shell Size	Ø A		Ø F		L		W		Y	
	Minimum		Maximum		Maximum		Maximum		Maximum	
	inch	mm	inch	mm	inch	mm	inch	mm	inch	mm
8	.337	8.56	.750	19.05	1.859	47.22	1.000	25.40	.828	21.03
10	.465	11.81	.859	21.82	1.859	47.22	1.032	26.21	.891	22.63
12	.557	14.15	1.031	26.19	1.938	49.23	1.094	27.79	1.016	25.81
14	.702	17.83	1.156	29.36	2.125	53.98	1.219	30.96	1.141	28.98
16	.827	21.01	1.281	32.54	2.281	57.94	1.281	32.54	1.255	31.88
18	.927	23.55	1.406	35.71	2.312	58.72	1.344	34.14	1.469	37.31
20	1.052	26.72	1.531	38.89	2.375	60.33	1.375	34.93	1.550	39.37
22	1.177	29.90	1.641	41.68	2.531	64.29	1.438	36.53	1.675	42.55
24	1.302	33.07	1.766	44.86	2.828	71.83	1.719	43.66	1.800	45.72

**Keying Positions**

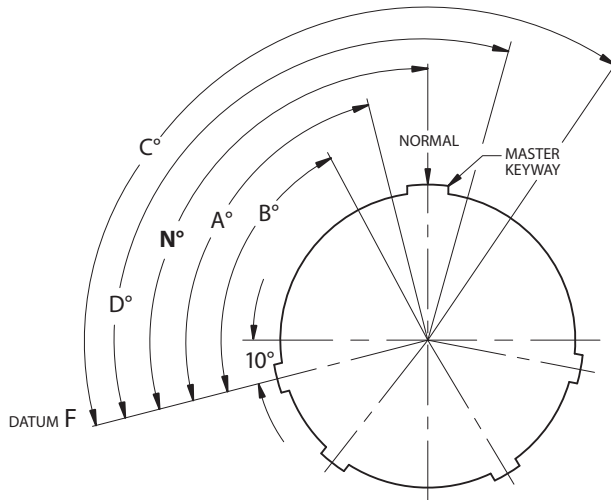

**Notes:**

1. Mating face of receptacle shown (plug is opposite).
2. The master keyway (key) has various positions relative to DATUM **F**; the minor keyways (keys) remain fixed as shown. In the Normal position, the master keyway (key) is 100° from DATUM **F**.
3. The angles for a given connector are the same whether it contains pin or socket inserts.
4. The insert arrangement does not rotate relative to master keyway (key).

Shell Size	Keying Positions				
	BSC				
	N°	A°	B°	C°	D°
8	100	82	-	-	118
10	100	86	72	128	114
12	100	80	68	132	120
14	100	79	66	134	121
16	100	82	70	130	118
18	100	82	70	130	118
20	100	82	70	130	118
22	100	85	74	126	115
24	100	85	74	126	115

Panel Cutouts

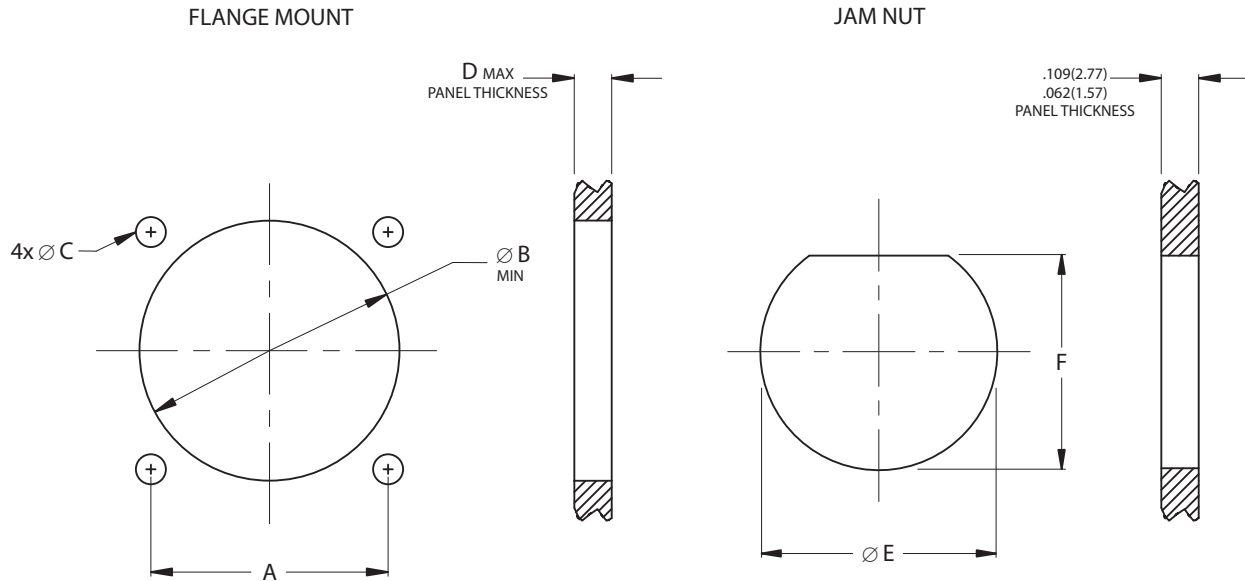

**Note 1:** Flange Mounting Dimensions ( $\varnothing$  B cutout and D MAX) listed only for back of panel mounting (MS27497 and MS27508).

**Note 2:** D MAX includes mounting hardware.

**Flange and Jam Nut Mounting Dimensions**

Shell Size	A		$\varnothing$ B		$\varnothing$ C		D		$\varnothing$ E		F	
	(TP)		Minimum		$\pm 0.005$	$\pm 0.13$	Maximum		+0.010	+0.25	+0.000	+0.00
	inch	mm	inch	mm	inch	mm	inch	mm	inch	mm	inch	mm
8	.594	15.09	.557	14.15	.128	3.25	.146	3.71	.885	22.48	.830	21.08
10	.719	18.26	.682	17.32	.128	3.25	.146	3.71	1.010	25.65	.955	24.26
12	.812	20.62	.854	21.69	.128	3.25	.146	3.71	1.135	28.83	1.085	27.56
14	.906	23.01	.979	24.87	.128	3.25	.146	3.71	1.260	32.01	1.210	30.73
16	.969	24.61	1.104	28.04	.128	3.25	.146	3.71	1.385	35.18	1.335	33.91
18	1.062	26.97	1.229	31.22	.128	3.25	.146	3.71	1.510	38.35	1.460	37.08
20	1.156	29.36	1.354	34.39	.128	3.25	.168	4.27	1.635	41.53	1.585	40.26
22	1.250	31.75	1.479	37.57	.128	3.25	.168	4.27	1.760	44.70	1.709	43.42
24	1.375	34.93	1.604	40.74	.154	3.91	.168	4.27	1.885	47.88	1.835	46.61

**MIL-DTL-38999****Contacts, Tools and Seal Plugs  
Series II****Contacts, Plastic Insertion/Removal Tools and Seal Plugs**

Contact Size	Application	Pin Contacts	Socket Contacts	Seal Plugs	Insertion/Removal Tools
	Type	Military No.	Military No.	Military No.	Military No.
22D	Power/Signal	M39029/58-360	M39029/57-354	MS27488-22-1	M81969/14-01
22M*	Power/Signal	M39029/58-361	M39029/57-355		—
22*	Power/Signal	M39029/58-362	M39029/57-356		—
20	Power/Signal	M39029/58-363	M39029/57-357	MS27488-20-1	M81969/14-10
16	Power/Signal	M39029/58-364	M39029/57-358	MS27488-16-1	M81969/14-03
16 Coax	Coax	M39029/76-424	M39029/78-432		M81969/14-04
12	Power/Signal	M39029/58-365	M39029/57-359	MS27488-12-1	M81969/14-04

**Crimping and Metal Insertion/Extraction Tools**

Contact Size/Type	Crimp Tool	Positioner	Positioner	Insertion Tool	Extraction Tool
	Military No.	Military No.	Military No.	Military No.	Military No.
22D, 22M*	M22520/2-01	M22520/2-09	M22520/2-06	M81969/8-01	M81969/8-02
22*	M22520/2-01	M22520/2-09	M22520/2-06	M81969/8-03	M81969/8-04
20	M22520/1-01	M22520/1-04	M22520/1-04	M81969/8-05	M81969/8-06
	M22520/2-01	M22520/2-10	M22520/2-10		
16	M22520/1-01	M22520/1-04	M22520/1-04	M81969/8-07	M81969/8-08
16 Coax Inner	M22520/2-01	M22520/2-35	M22520/2-35		
16 Coax Outer	M22520/4-01	M22520/4-02	M22520/4-02		
12	M22520/1-01	M22520/1-04	M22520/1-04	M81969/8-09	M81969/8-10

**Contact and Wire Data**

Contact Size	Test Current	Voltage	Crimp Well Data			Wire Range		Finished Wire Ø Range			
	DC Test	Max. Drop	Well Dia.	Minimum Well Dept		AWG	mm <sup>2</sup>	Minimum		Maximum	
	Amps	Millivolts	inch	inch	mm			inch	mm	inch	mm
22D	5.0	73	.0345 ±.0010	.141	3.58	28-22	.08-.33	.030	.76	.054	1.37
22M*	3.0	45	.028 ±.001	.141	3.58	28-24	.08-.20	.030	.76	.050	1.27
22*	5.0	73	.0365 ±.0010	.141	3.58	26-22	.13-.33	.034	.86	.060	1.52
20	7.5	55	.047 ±.001	.209	5.31	24-20	.20-.52	.040	1.02	.083	2.11
16	13.0	49	.067 ±.001	.209	5.31	20-16	.52-1.31	.065	1.65	.109	2.77
12	23.0	42	.100 ±.002	.209	5.31	14-12	2.08-3.31	.097	2.46	.142	3.61

\* Inactive for new design

**Note 1:** Test Current and Maximum Voltage Drop when tested with silver-plated wire at 25°C.**Note 2:** Size 16 coax contacts purchased in bulk.

MIL-DTL-38999 S II



# Contact Installation Instructions

## Crimping Contacts

1. Select the appropriate crimp tool and ensure that the proper crimp head positioner is used.
2. Cycle the tool to be sure the indentors are open.
3. Determine the correct selector setting for the wire size from the data plate on the positioner (turret head assembly) and set the selector knob on the crimp tool to match.
4. Place the contact, mating end first, into the tool.
5. Insert the stripped wire into the hollow end of the contact. Be sure the wire is inserted as far as it will go.
6. Close the tool completely to crimp. Unless the tool is closed completely, the tool will not release the contact.
7. Remove the crimped contact from the tool. Check the inspection hole to verify that the wire is fully inserted.

## Insertion of Contacts

1. Before inserting the contacts, unscrew the accessories (clamps, backshells or adapters) from rear of plug or receptacle. Slide the hardware over the wire bundle in the proper order for reassembly after all the contacts are inserted.
2. To assist insertion of contacts, lubricate insulator (grommet) cavities with isopropyl alcohol. Alcohol will evaporate and will not leave a conductive film. **Caution: Never use any lubricant other than isopropyl alcohol.**

3. Place the correct insertion tool on the contact so that the wire runs along the groove in the tool. (Tool tip will butt against the shoulder.) Hold the plug or receptacle body firmly.
4. Beginning with a center cavity, insert the contact into the insulator with a slow, even pressure until the contact snaps into position. Make sure the contact and tool are held perpendicular to the face of the insert during the contact installation or the grommet could be damaged.
  - 4.1 If contacts are not inserted all the way prior to removing insertion tool, do not try to reinsert the insertion tool. Instead, remove the contact and try again; otherwise reinserting the insertion tool may damage the inside of the contact cavity.
5. Remove tool and check the face of the connector for proper contact installation. Proper installation may also be checked by pulling back lightly on the wire to make sure the contact is properly seated.

## Completion

After all the cavities have been filled, slide the hardware back into position on the connector and tighten.

## Extraction of Contacts (Rework)

1. Slide the hardware back over the wire bundle.
2. Select the appropriate tool. Place the wire into the extraction tool of the pin or socket.
3. Slowly slide the extraction tool down wire into the contact cavities until the tool tip bottoms against the contact shoulder, expanding the clip retaining tines. Hold the wire firmly in the tool and pull the wired contact and tool straight out of the rear of the insulator.

Size	Pin Contact	Socket Contact	Basic Crimp Tool	Pin Positioner	Socket Positioner	Insertion/Removal Tool
22D	M39029/58-360	M39029/57-354	M22520/2-01	M22520/2-09	M22520/2-06	M81969/14-01
22M	M39029/58-361	M39029/57-355	M22520/2-01	M22520/2-09	M22520/2-06	M81969/14-01
22	M39029/58-362	M39029/57-356	M22520/2-01	M22520/2-09	M22520/2-06	M81969/14-01
20	M39029/58-363	M39029/57-357	M22520/1-01	M22520/1-04 Red	M22520/1-04 Red	M81969/14-10
			M22520/2-01	M22520/2-10	M22520/2-10	
16	M39029/58-364	M39029/57-358	M22520/1-01	M22520/1-04 Blue	M22520/1-04 Blue	M81969/14-03
12	M39029/58-365	M39029/57-359	M22520/1-01	M22520/1-04 Yellow	M22520/1-04 Yellow	M81969/14-04

For coax contacts refer to instructions supplied with contacts.