

1A, 400V ESD Capability Rectifier

FEATURES

- High ESD capability
- Glass passivated chip junction
- Ideal for automated placement
- Low forward voltage drop
- High surge current capability
- Compliant to RoHS Directive 2011/65/EU and in accordance to WEEE 2002/96/EC
- Halogen-free according to IEC 61249-2-21

APPLICATIONS

- Switching mode power supply (SMPS)
- Adapters
- Lighting application
- Converter

MECHANICAL DATA

- Case: DO-214AC (SMA)
- Molding compound meets UL 94V-0 flammability rating
- Part no. with suffix "H" means AEC-Q101 qualified
- Packing code with suffix "G" means green compound (halogen-free)
- Moisture sensitivity level: level 1, per J-STD-020
- Terminal: Matte tin plated leads, solderable per J-STD-002
- Meet JESD 201 class 2 whisker test
- Polarity: As marked
- Weight: 0.06 g (approximately)

KEY PARAMETERS		
PARAMETER	VALUE	UNIT
$I_{F(AV)}$	1	A
V_{RRM}	400	V
I_{FSM}	40	A
V_F at $I_F=2A$	1	V
T_{JMAX}	175	°C
Package	DO-214AC (SMA)	
Configuration	Single die	



DO-214AC (SMA)

SOLUTE MAXIMUM RATINGS ($T_A = 25^\circ\text{C}$ unless otherwise noted)			
PARAMETER	SYMBOL	TSD1G	UNIT
Marking code on the device		TSD1G	
Repetitive peak reverse voltage	V_{RRM}	400	V
Reverse voltage, total rms value	$V_{R(RMS)}$	280	V
Forward current	$I_{F(AV)}$	1	A
Surge peak forward current, 8.3 ms single half sine-wave superimposed on rated load per diode	I_{FSM}	40	A
Junction temperature	T_J	- 55 to +175	°C
Storage temperature	T_{STG}	- 55 to +175	°C

THERMAL PERFORMANCE			
PARAMETER	SYMBOL	LIMIT	UNIT
Junction-to-lead thermal resistance	$R_{\theta JL}$	39	$^{\circ}C/W$
Junction-to-ambient thermal resistance	$R_{\theta JA}$	86	$^{\circ}C/W$
Junction-to-case thermal resistance	$R_{\theta JC}$	43	$^{\circ}C/W$

Thermal Performance Note: Units mounted on recommended PCB (5mm x 5mm Cu pad test board)

ELECTRICAL SPECIFICATIONS ($T_A = 25^{\circ}C$ unless otherwise noted)					
PARAMETER	CONDITIONS	SYMBOL	TYP	MAX	UNIT
Forward voltage per diode ⁽¹⁾	$I_F = 1A, T_J = 25^{\circ}C$	V_F	0.89	1.25	V
	$I_F = 0.5A, T_J = 25^{\circ}C$		0.85	1.00	V
	$I_F = 1A, T_J = 125^{\circ}C$		0.77	1.10	V
	$I_F = 0.5A, T_J = 125^{\circ}C$		0.72	0.90	V
Reverse current @ rated V_R per diode ⁽²⁾	$T_J = 25^{\circ}C$	I_R	-	1.00	μA
	$T_J = 125^{\circ}C$		-	50	μA
Junction capacitance	1 MHz, $V_R = 4.0V$	C_J	14	-	pF

Notes:

1. Pulse test with $PW = 0.3$ ms
2. Pulse test with $PW = 30$ ms

IMMUNITY TO ELECTRICAL STATIC DISCHARGE TO THE FOLLOWING STANDARDS ($T_A = 25^{\circ}C$ unless otherwise noted)						
Standard	Test Type	Test Conditions	SYMBOL	CLASS	Value	Typical
AEC-Q101-001	Human body model(contact mode)	$C = 100pF, R = 1.5k\Omega$	V_C	H3B	$\geq 8kV$	N/A
IEC 61000-4-2	Contact mode	$C = 150pF, R = 330\Omega$		4	$\geq 8kV$	20kV
	Air-discharge mode	$C = 150pF, R = 330\Omega$		4	$\geq 15kV$	25kV
ISO 10605	Contact mode	$C = 330pF, R = 330\Omega$		L4	$\geq 15kV$	20kV
	Air-discharge mode	$C = 330pF, R = 330\Omega$		L4	$\geq 25kV$	25kV

ORDERING INFORMATION

PART NO.	PART NO. SUFFIX	PACKING CODE	PACKING CODE SUFFIX	PACKAGE	PACKING
TSD1G (Note 1)	H	R3	G	SMA	1,800 / 7" Plastic reel
		R2		SMA	7,500 / 13" Paper reel
		M2		SMA	7,500 / 13" Plastic reel
		F3		Folded SMA	1,800 / 7" Plastic reel
		F2		Folded SMA	7,500 / 13" Paper reel
		F4		Folded SMA	7,500 / 13" Plastic reel

Note:

1. Whole series with green compound (halogen-free)

EXAMPLE

EXAMPLE P/N	PART NO.	PART NO. SUFFIX	PACKING CODE	PACKING CODE SUFFIX	DESCRIPTION
TSD1GHR3G	TSD1G	H	R3	G	AEC-Q101 qualified Green compound

CHARACTERISTICS CURVES

($T_A = 25^\circ\text{C}$ unless otherwise noted)

Fig.1 Forward Current Derating Curve

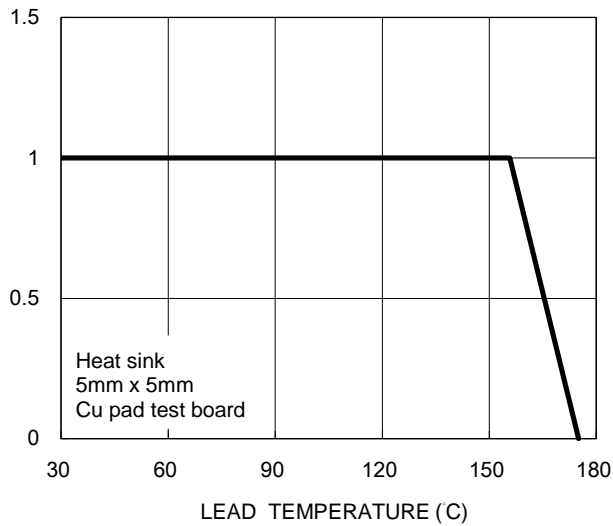

Fig.2 Typical Junction Capacitance

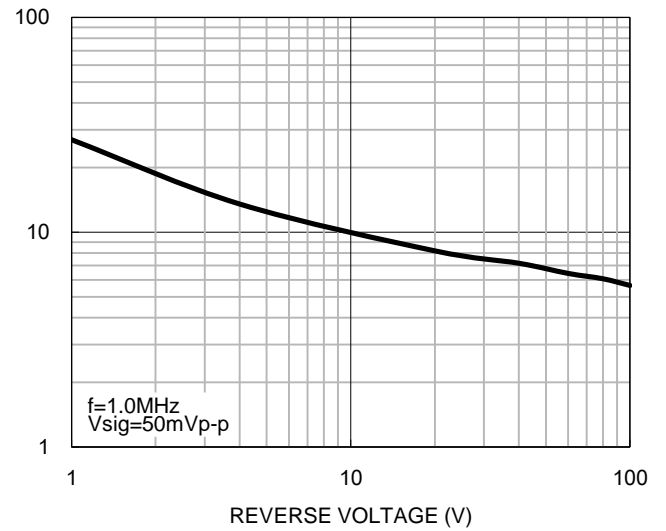

Fig.3 Typical Reverse Characteristics

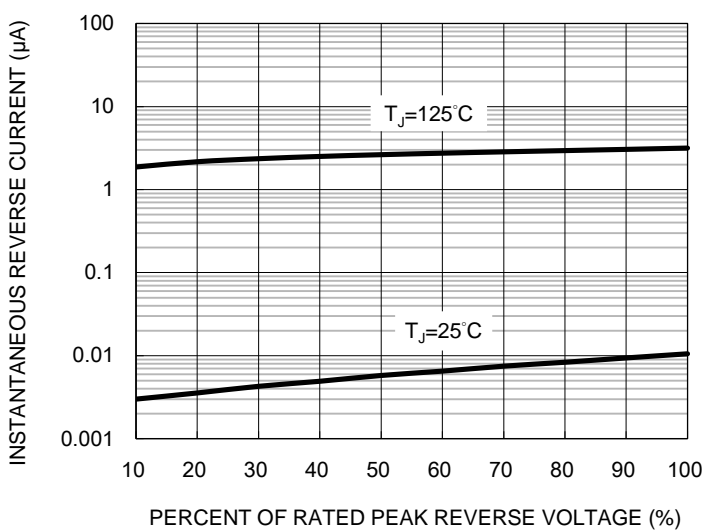
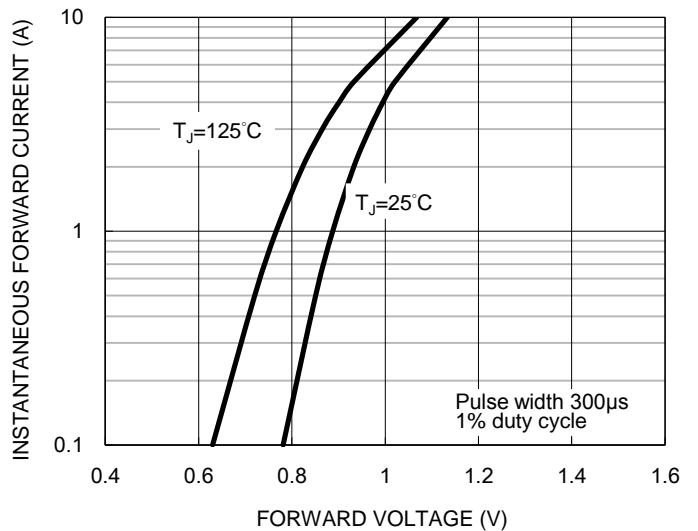
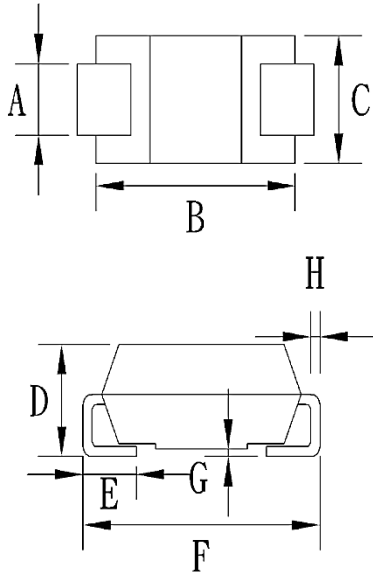

Fig.4 Typical Forward Characteristics



PACKAGE OUTLINE DIMENSIONS



DIM.	Unit (mm)		Unit (inch)	
	Min	Max	Min	Max
A	1.27	1.58	0.050	0.062
B	4.06	4.60	0.160	0.181
C	2.29	2.83	0.090	0.111
D	1.99	2.50	0.078	0.098
E	0.90	1.41	0.035	0.056
F	4.95	5.33	0.195	0.210
G	0.10	0.20	0.004	0.008
H	0.15	0.31	0.006	0.012

SUGGESTED PAD LAYOUT

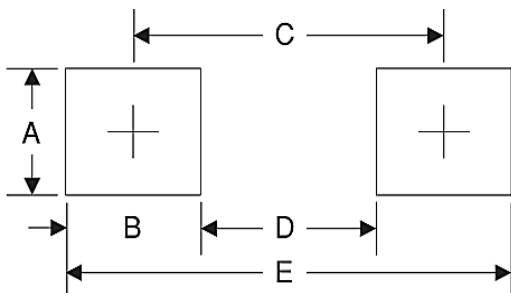

Symbol	Unit (mm)	Unit (inch)
A	1.68	0.066
B	1.52	0.060
C	3.93	0.155
D	2.41	0.095
E	5.45	0.215

MARKING DIAGRAM



- P/N =Marking Code
- G =Green Compound
- YW =Date Code
- F =Factory Code

Notice

Specifications of the products displayed herein are subject to change without notice. TSC or anyone on its behalf, assumes no responsibility or liability for any errors or inaccuracies.

Information contained herein is intended to provide a product description only. No license, express or implied, to any intellectual property rights is granted by this document. Except as provided in TSC's terms and conditions of sale for such products, TSC assumes no liability whatsoever, and disclaims any express or implied warranty, relating to sale and/or use of TSC products including liability or warranties relating to fitness for a particular purpose, merchantability, or infringement of any patent, copyright, or other intellectual property right.

The products shown herein are not designed for use in medical, life-saving, or life-sustaining applications. Customers using or selling these products for use in such applications do so at their own risk and agree to fully indemnify TSC for any damages resulting from such improper use or sale.