

NEW

0.35mm pitch, 0.7/0.8mm mated height, high retention Strength Connectors PCB-to-PCB and PCB-to-FPC Connectors

BM15FR Series

Complies with RoHS

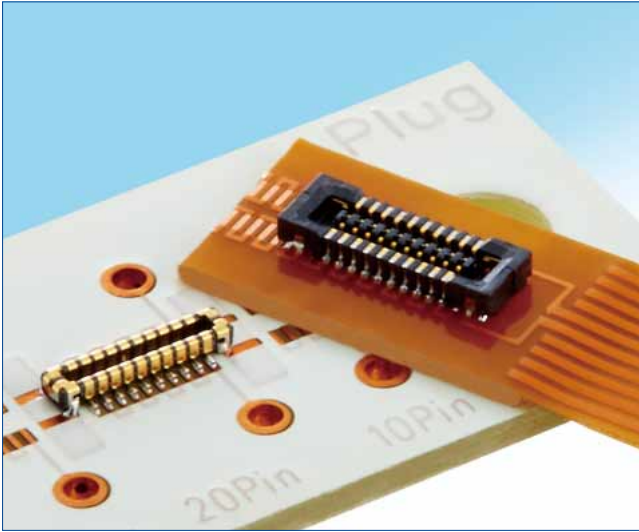

PCB Board area

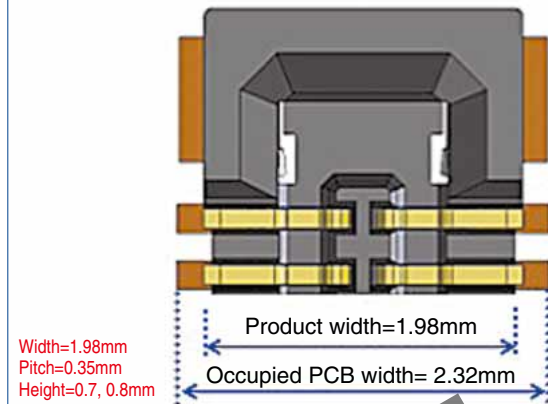

Features

1. High retention strength

Metal fittings in the locking mechanism assure high pull-out forces.

2. Space-saving

Space-saving design with a depth of a of 2mm max. and a pitch of 0.35mm.
Depth DS side :1.98mm, DP side:1.58mm

3. High contact reliability

The BM15 provides high contact reliability with its 2-point contact structure, while maintaining the low mated height of 0.7 or 0.8mm.

4. PCB layout

The outstanding electrical insulation on the bottom side of the BM15FR connectors and the PCB provides flexibility and lifts PCB layout restrictions.

5. Enhanced operability

The guide rib ensures correct alignment during mating with a self alignment range of 0.3mm. In addition, a tactile click and improves operability.

6. Protection against shock and vibration

The lock mechanism of the plug contact absorbs forces caused by impact or vibration.

Highly reliable contact structure

[1]High retention strength is resistant to pull out forces.

The strength is created by a "pocket and bump" contact locking grooves and locking metal fittings

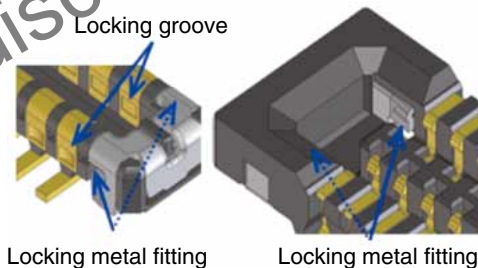

Fig.1. Geometry of the contact locking groove and the locking metal fitting

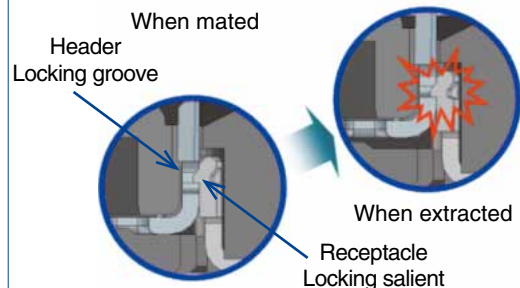
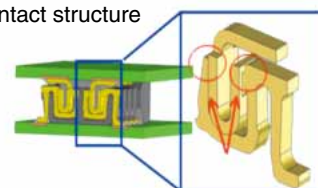

Fig.2. Structure of the locking metal fitting

Retention force is at least twice that of existing products

[2] 2-point contact structure



Two highly-reliable contact points

Product specifications

Rated value	Rated current	0.3A	Operation temperature range	-35 to 85°C (Note 1)	Storage temperature range	-10 to 60°C (Note 2)
	Rated Voltage	AC,DC 30V	Operation humidity range	20 to 80 % RH	Storage humidity range	40-70% RH (Note 2)

Items	Specifications	Conditions
1. Insulation resistance	Minimum of 50MΩ	Measured at DC 100V
2. Withstanding voltage	No flashover or dielectric breakdown.	AC 100V for one minute
3. Contact resistance	Maximum of 100mΩ	Measured at AC20mV, 1kHz, and 1mA
4. Vibration resistance	No electrical discontinuity of 1μs or greater.	Frequency: 10 to 55 Hz; half amplitude: 0.75 mm, in 3 directions for 2 hours
5. Moisture resistance	Contact resistance: a maximum of 100mΩ; insulation resistance: a minimum of 25MΩ	Left for 96 hours at 40 °C ±2 °C and humidity of 90 to 95 %
6. Temperature cycle	Contact resistance: a maximum of 100mΩ; insulation resistance: a minimum of 50MΩ	(-55°C for 30 minutes → 5 to 35 °C for 10 minutes → 85 °C for 30 minutes → 5 to 35 °C for 10 minutes) in 5 cycles
7. Mating cycles	Contact resistance: a maximum of 100mΩ	10 times
8. Solder heat resistance	No melting of resin parts that will effect the performance.	Reflow: Hand soldering at the recommended temperature profile with the temperature of the solder iron at 350°C for 3 seconds

Note 1 : Includes temperature rise caused by current flow.

Note 2 : The term “storage” refers to the long-term-storage status of unused items before mounting on the PCB.

The operating temperature/humidity ranges apply to the unmated state after board mounting.

Material

Item	Part	Material	Finish	UL specification
Receptacle	Insulator	LCP	Black	UL94V-0
Header	Contact	Phosphor bronze	Gold plating	—

Part Number Structure

Refer to this page for product specifications and model types.

The characteristics and specifications of the product described in this catalog are reference values. Please make sure to check the latest delivery specifications at the time of purchase.

● Receptacle/header

BM 15 FR 0.8 – * DS – 0.35 V (51)

① ② ③ ④ ⑤ ⑥ ⑦ ⑧ ⑨

① Series Name: BM	④ Stack	Indication	Stacking height	⑥ Connector type DS: Double row receptacle DP: Double row header
② Series No. : 15				
③ Shape designation Receptacle FR: With locking metal fitting Header FR: With locking metal fitting	Receptacle	0.7	0.7mm	⑦ Contact pitch: 0.35mm
	Header	0.8	0.8mm	
		None	0.7mm	⑧ Terminal shape V: Straight SMT
	⑤ Number of contacts	0.8	0.8mm	⑨ Package type (51): Embossed tape packaging (15,000 pcs/reel)

■ H=0.7/0.8mm receptacle

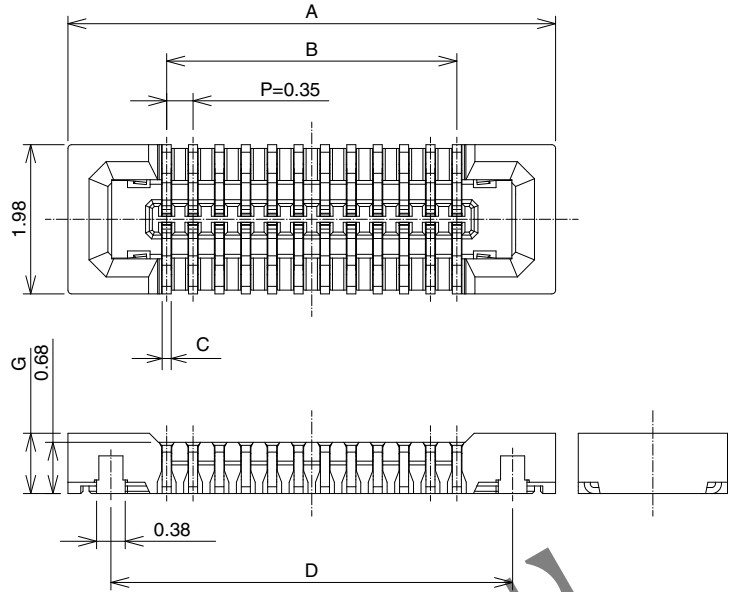

◆ Recommended PCB layout

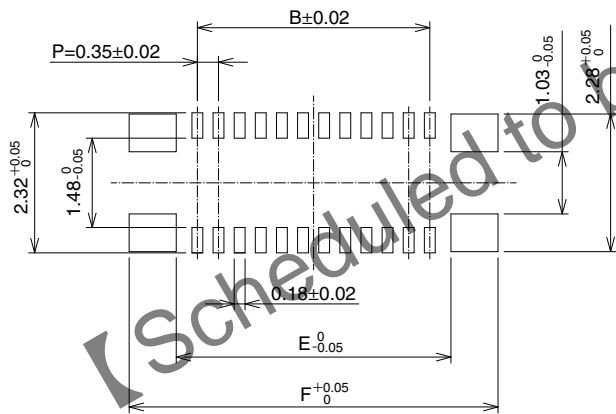

◆ Recommended metal mask dimensions (mask thickness 100µm)

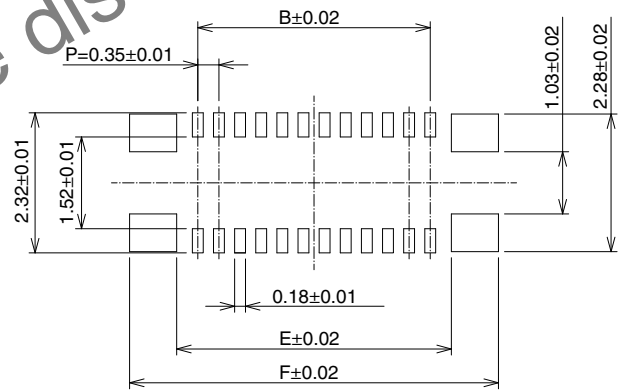

[mm]										
Height	Part No.	HRS No.	No. of contacts	A	B	C	D	E	F	G
0.7	BM15FR0.7-10DS-0.35V(51)	673-1269-0 51	10	4.02	1.4	0.12	2.88	2.1	3.66	0.7
0.8	BM15FR0.8-10DS-0.35V(51)	673-1225-5 51	10	4.02	1.4	0.12	2.88	2.1	3.66	0.8
	BM15FR0.8-20DS-0.35V(51)	673-1227-0 51	20	5.77	3.15		4.63	3.85	5.41	
	BM15FR0.8-22DS-0.35V(51)	673-1220-1 51	22	6.12	3.5		4.98	4.2	5.76	
	BM15FR0.8-24DS-0.35V(51)	673-1229-6 51	24	6.47	3.85	5.33	4.55	6.11		
	BM15FR0.8-30DS-0.35V(51)	673-1244-0 51	30	7.52	4.9	0.1	6.38	5.6	7.16	

Note 1 : This product is sold on 15,000 pcs/reel reels. Please place orders in full reel quantities.

Note 2 : This connector has no polarity.

Note 3 : Please contact our sales dept. for pin counts not listed above.

■ H=0.7/0.8mm Header

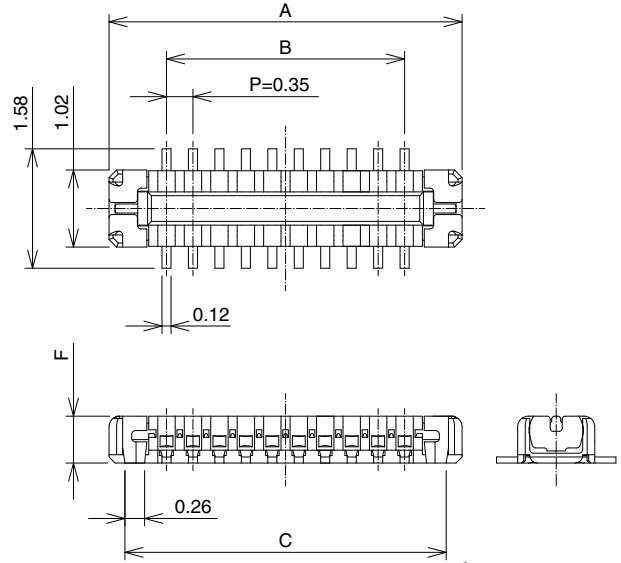
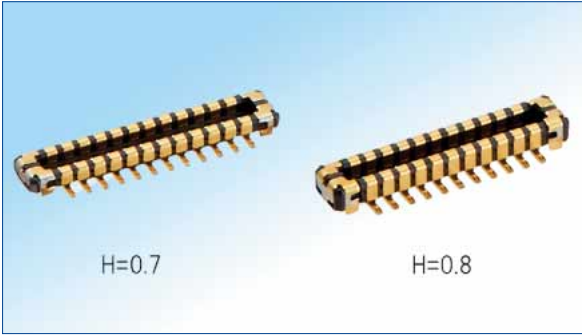

◆ Recommended PCB layout

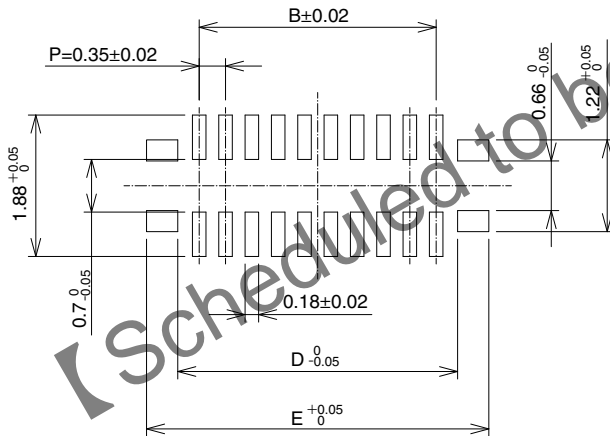

◆ Recommended metal mask dimensions (mask thickness 100µm)

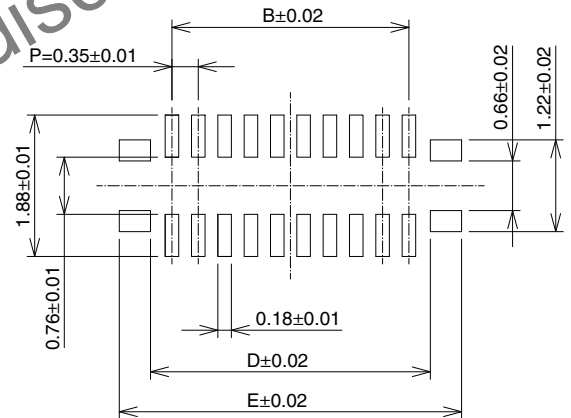

[mm]									
Height	Part No.	HRS No.	No. of contacts	A	B	C	D	E	F
0.7	BM15FR-10DP-0.35V(51)	673-1272-5 51	10	2.92	1.4	2.5	1.97	2.8	0.46
0.8	BM15FR0.8-10DP-0.35V(51)	673-1226-8 51	10	2.92	1.4	2.5	1.97	2.8	0.62
	BM15FR0.8-20DP-0.35V(51)	673-1228-3 51	20	4.67	3.15	4.25	3.72	4.55	
	BM15FR0.8-22DP-0.35V(51)	673-1224-2 51	22	5.02	3.5	4.6	4.07	4.9	
	BM15FR0.8-24DP-0.35V(51)	673-1230-5 51	24	5.37	3.85	4.95	4.42	5.25	
	BM15FR0.8-30DP-0.35V(51)	673-1243-7 51	30	6.42	4.9	6	5.47	6.3	

Note 1 : This product is sold on 15,000 pcs/reel. Please place orders in full reel quantities.

Note 2 : This connector has no polarity.

Note 3 : Please contact our sales dept. for pin counts not listed above.

◆ Embossed tape dimension diagram (based on JIS C 0806)

● Receptacle

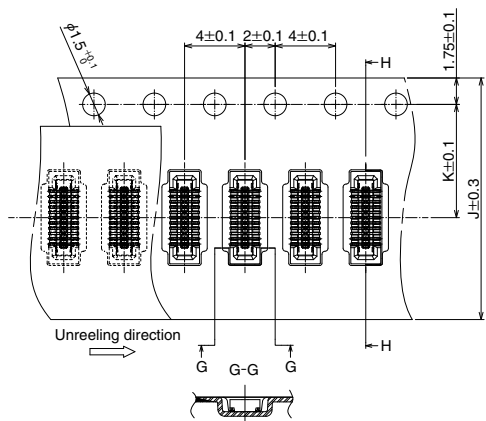

● Header

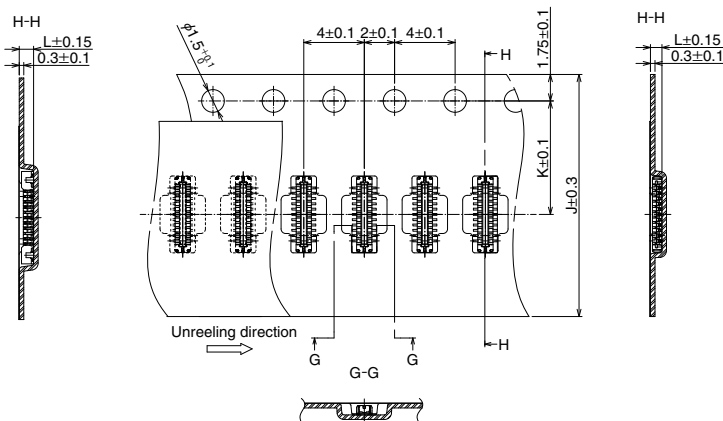

● Reel dimension diagram

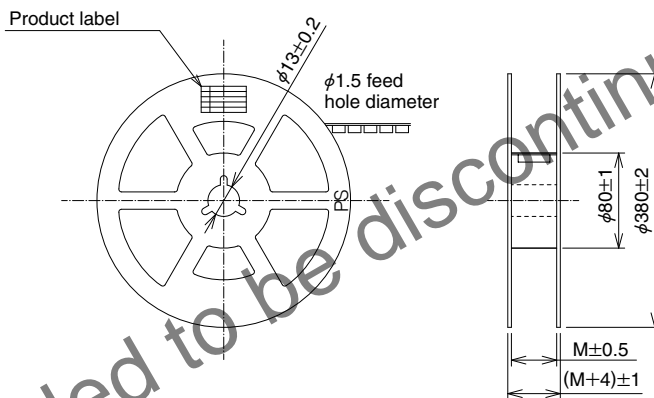

[mm]

Height	Part No.	HRS No.	No. of contacts	J	K	L	M
0.7	BM15FR0.7-10DS-0.35V(51)	673-1269-0 51	10	16	7.5	0.85	17.5
0.8	BM15FR0.8-10DS-0.35V(51)	673-1225-5 51	10	16	7.5	0.95	17.5
	BM15FR0.8-20DS-0.35V(51)	673-1227-0 51	20				
	BM15FR0.8-22DS-0.35V(51)	673-1220-1 51	22				
	BM15FR0.8-24DS-0.35V(51)	673-1229-6 51	24				
	BM15FR0.8-30DS-0.35V(51)	673-1244-0 51	30	24	11.5		21.5

Height	Part No.	HRS No.	No. of contacts	J	K	L	M
0.7	BM15FR-10DP-0.35V(51)	673-1272-5 51	10	12	5.5	0.61	13.5
0.8	BM15FR0.8-10DP-0.35V(51)	673-1226-8 51	10	12	5.5	0.76	17.5
	BM15FR0.8-20DP-0.35V(51)	673-1228-3 51	20				
	BM15FR0.8-22DP-0.35V(51)	673-1224-2 51	22	16	7.5		
	BM15FR0.8-24DP-0.35V(51)	673-1230-5 51	24				
	BM15FR0.8-30DP-0.35V(51)	673-1243-7 51	30				

Apr. 1. 2026 Copyright 2026 HIROSE ELECTRIC CO., LTD. All Rights Reserved.

◆ Usage Recommendations

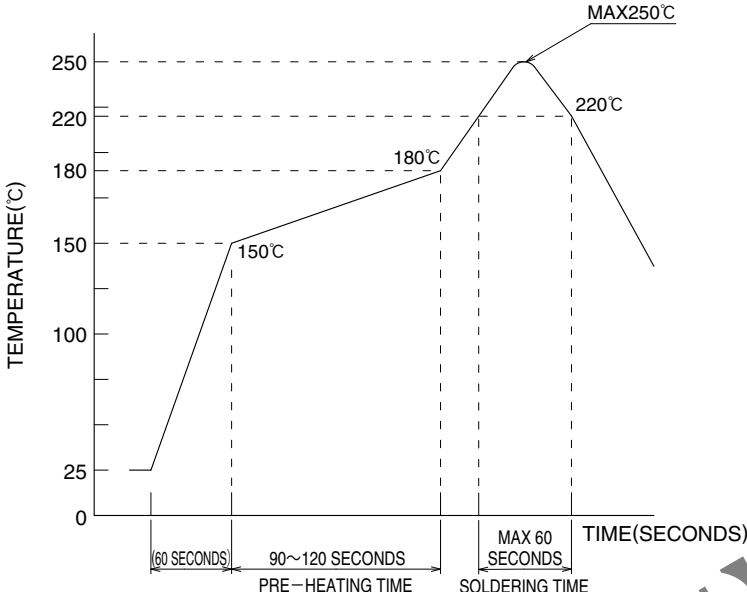
<p>1. Recommended temperature profile</p>	 <p>[Conditions]</p> <ol style="list-style-type: none"> 1. Peak temperature At a peak of 250°C 2. Heating part Minimum of 220°C Maximum of 60 seconds 3. Preheating part 150-180°C 90-120sec 4. Number of times Maximum of 2 times <p>Note 1 : Temperature is the surface temperature of the PCB in the connector lead portion area. Note 2 : When using a nitrogen reflow process, please mount the product with the oxygen concentration at a minimum of 1,000 [ppm]. Please contact us if the concentration is below 1,000 [ppm].</p>
<p>2. Recommended hand soldering conditions</p>	<p>Soldering iron temperature: 340 ±10°C; soldering time: within 3 seconds.</p>
<p>3. Recommended screen thickness/aperture ratio (pattern area ratio)</p>	<p>Thickness: 0.1mm Contact aperture ratio: 95% on the DS side; 95% on the DP side, aperture ratio of the metal fitting: 100% for both DS and DP.</p>
<p>4. Warpage of the PCB</p>	<p>A maximum of 0.02mm at the center part of the connector based on both ends of the connector</p>
<p>5. Cleaning</p>	<p>Not recommended. If you clean this product, please re-evaluate its performance before using it. Cleaning may cause a change in the mating/unmating properties as well as environmental resistances.</p>
<p>6. Notes</p>	<ul style="list-style-type: none"> ■ Mating/unmating the product when it is not mounted on the PCB could cause damage or deformation of the contact. ■ Avoid supporting the PCB only by connectors. The board should be supported by other means such as with posts and screws on the PCB. ■ Improper mating/unmating can cause damage to the contacts. ■ When hand soldering, please do not apply excess amounts of flux as this could cause flux wicking. ■ This product may differ slightly in color due to production lot variability, but color variation has no influence on the performance. ■ Please refer to the next page for the precautions for mating/unmating. ■ To prevent the possibility of unmating caused by dropping, impact and routing of FPC, it is recommended to stabilize the connector in the mated state by using housings or cushioning materials.

Apr. 1. 2026 Copyright 2026 HIROSE ELECTRIC CO., LTD. All Rights Reserved.

● Notes when mating connector

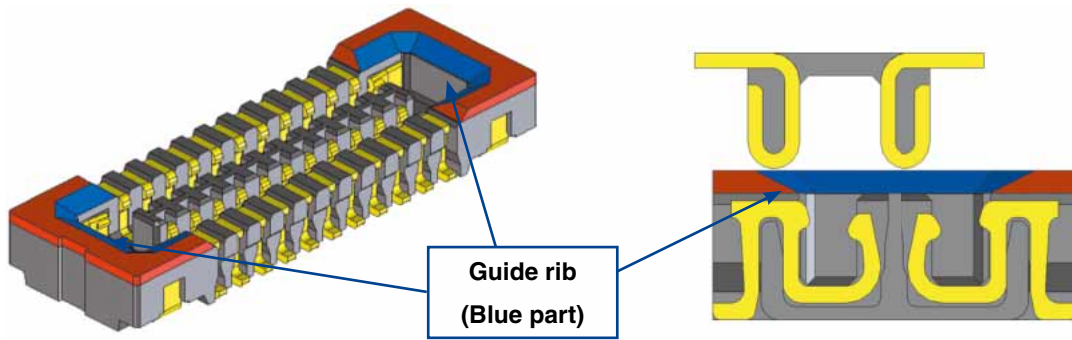

Position the two connectors together by hand for the initial mating operation. This product is equipped with a guide rib on the outer wall of the mold (blue + red areas noted in the figure above) for correct mating. Position the male side connector so that the female side connector is positioned into chamfer indicated by the blue area.

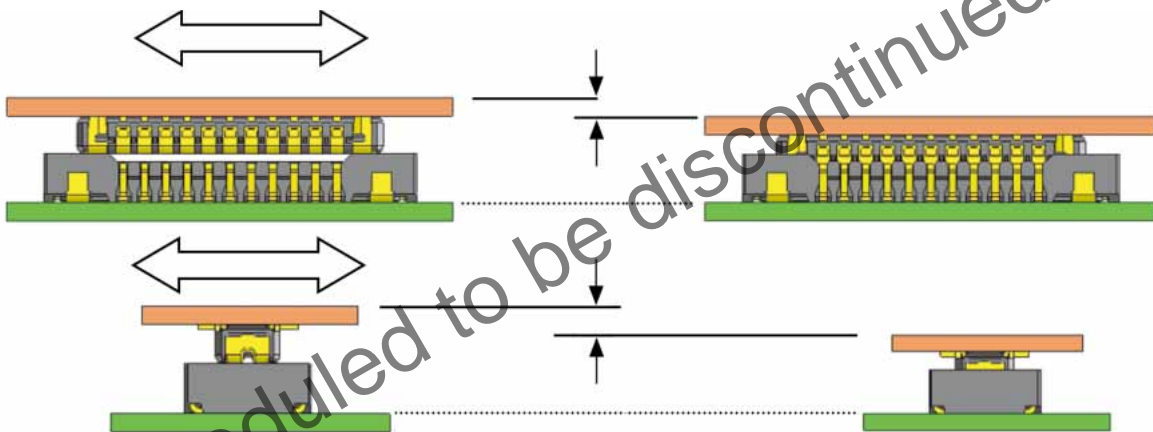

Do not apply excessive force during the initial mating operation. Too much force will cause damage and or shaving of the mold. This may lead to a failure in contact resistance.



After the initial mating is accomplished, the connectors will drop down in to the fully mated state

●Notes when unmating connector

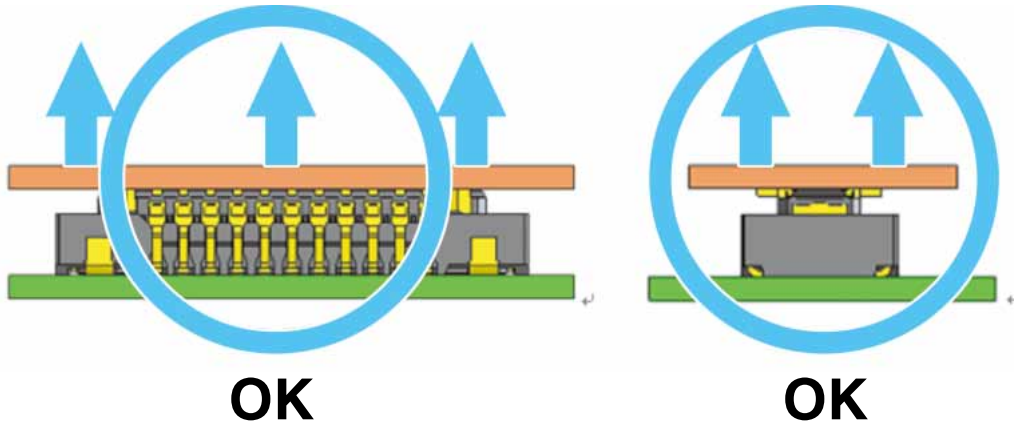

Hirose recommends unmating in a vertical direction



If it is difficult to remove the connector, detach it in an angled direction along the long axis of the connector. Be careful not to remove the connector in the short axis direction, as doing so puts a heavy load on the contact. When removing it in the short axis direction, be sure to pull out the tipped-up end of the FPC in the vertical direction. (A horizontal force will produce a heavy load on the contact.)

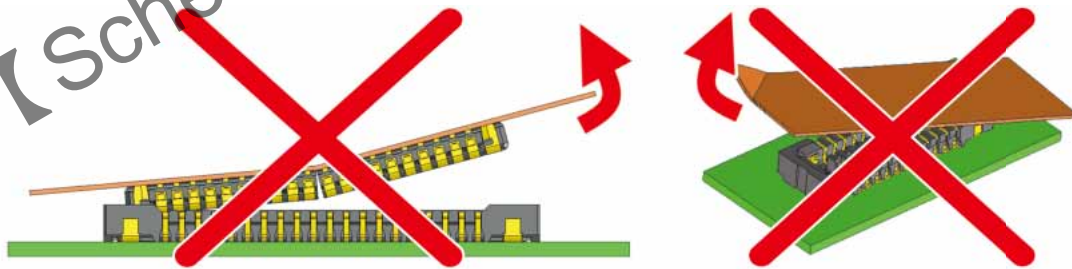

Please use a proper stiffener on the back of the FPC. We recommend using a glass epoxy material with a minimum thickness of 0.3mm or a stainless steel material with a minimum of thickness of 0.2mm. If the FPC stiffener is not rigid enough, solder separation (peeling) and connector breakage could occur during unmating. Be sure to properly test the FPC and soldering specifications, etc. Additionally, attempting to remove the FPC at an angle while holding the corner will produce a heavy load on the contact.

HIROSE ELECTRIC CO.,LTD.

2-6-3,Nakagawa Chuoh,Tsuzuki-Ku,Yokohama-Shi 224-8540,JAPAN
<https://www.hirose.com/>