

Rev	AWO #	Description	Date	Appr
-		RELEASED	2/16/12	

APPROVED: _____
 DATE: _____ TITLE: _____

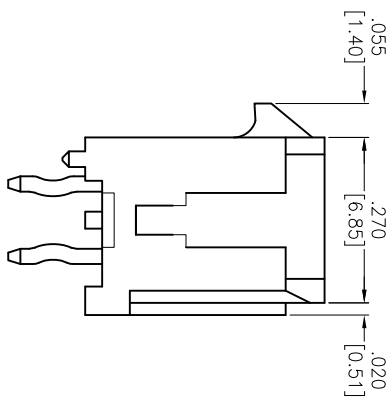
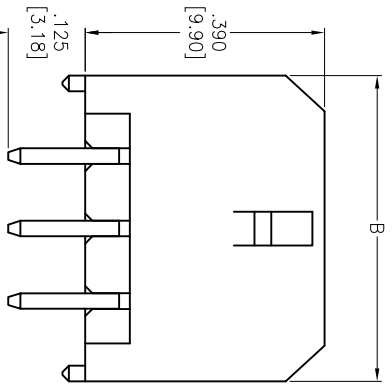
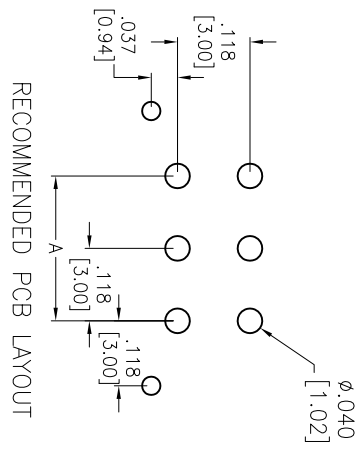
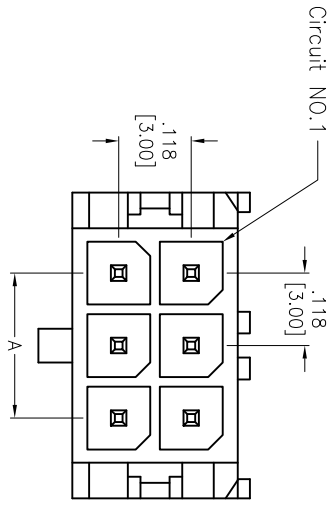

SPECIFICATIONS:
 Material: Insulator: Hi-temp thermoplastic, rated UL 94V-0
 Insulator color: Black
 Contacts: Brass
 Plating: 15u" Gold over Nickel underplate overall

Electrical:
 Operating voltage: 20 & 22 Awg: 5 Amps max
 Current rating: 20 & 22 Awg: 5 Amps max
 24 Awg: 4 Amps max
 26 Awg: 3 Amps max
 28 Awg: 2 Amps max
 30 Awg: 1 Amp max

Dielectric strength: 1500 VAC for 1 minute
Temperature Rating: Operating temperature: -25°C to +85°C

Environmental: Lead free, RoHS compliant.
 Recommended soldering temp: 260°C for 5 sec.

Positions: 2 thru 24
 A = .118 [3.00] x No. of Spaces
 B = .118 [3.00] x No. of Spaces + .262 [6.65]

UNLESS OTHERWISE SPECIFIED	
ALL DIMENSIONS ARE INCHES [MM]	
TOLERANCES: EXCEPT AS NOTED	
INCHES	HOLDS
.X ± .10	ØX ± .10
.XX ± .020	ØXX ± .015
.XXX ± .015	ØXXX ± .010
APPROVALS	
DATE	DATE
DRAWN AY	2/16/12
CHECKED AY	2/16/12
APPROVED	

ADAM TECH
 909 Rahway Avenue, Union, NJ 07083
 Phone: 908-687-5000 Fax: 908-687-5710

TITLE: .118" [3.00mm] MICRO FIT HEADER
 DUAL ROW VERTICAL

SIZE	PART NO.	REV.
X	DML-XX-A-V-G-A-15	-
REF: 500/23T	SCALE: NTS	SHEET 1 OF 1

ROHS COMPLIANT