

BT24 Datasheet

Amp'ed RF Technology, Inc.

BT24 Product Specification

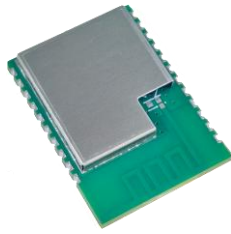

15.2mm x 20.8mm

Description

Amp'ed RF Technology presents our BT24 Bluetooth module, low cost series. For applications requiring basic Bluetooth functionality, the BT24J is the most cost effective dual mode module available. With support for both SPP and Apple IAP profiles, the BT24H can work with almost any mobile device or smart phone on the market, to quickly bring your wireless applications to market. The BT24B modules add extra processing support for high-fidelity stereo audio applications.

The BT24 includes an integrated antenna, 13 GPIOs, SPI, I2C, PCM, DAC and A/D lines. Our standard abSerial and Amp'edUP Stack Lite are pre-flashed into the integrated flash memory. Customized firmware for peripheral device interaction, power optimization, security, and other proprietary features may be supported and can be ordered pre-loaded and configured.

Bluetooth features

- Bluetooth qualified module
- Bluetooth v5.0
- Class 2 radio
- Range up to 80m LOS
- 600Kbps data throughput
- 128-bit encryption security

Hardware configuration

- Cortex-M4 microprocessor up to 240MHz
- 64K/128K/256K/2M bytes Flash memory
- 8K/16K/64K/960K bytes RAM memory
- UART, up to 921K baud
- SPI and I2C interfaces
- 13 general purpose I/O
- PCM audio interface
- 1 x12-bit A/D inputs
- 2 x 16-bit DAC output

Embedded software

- Amp'edUP Bluetooth stack (SPP, IAP, A2DP, HID, HFP)
- Support Apple iOS/MFI Bluetooth devices
- abSerial, AT command set
- BlueGuard, data encryption software (Optional)
- Mobile application software (Optional)

Additional documentation

- *abSerial User Guide*
- *abSerial Reference Guide*
- *abSerial Configuration Guide*

Table of Contents

1. Software Architecture	4
1.1. Lower Layer Stack	4
1.2. Upper Layer Stack: Amp'ed UP Lite	4
1.3. HCI Interface	4
1.4. AT Command Set: abSerial	4
2. Hardware Specifications	6
2.1. Recommended Operating Conditions	6
2.2. Absolute Maximum Ratings	6
2.3. Current Consumption	6
2.4. Selected RF Characteristics	6
2.5. I/O Operating Characteristics	7
2.6. Pin Assignment	8
2.7. Layout Drawing	9
3. Module Block Diagram	10
4. Hardware Design	12
4.1. Module Reflow Installation	12
4.2. GPIO Interface	12
4.3. UART Interface	13
4.4. PCB Layout Guidelines	14
4.5. Reset Circuit	14
4.5.1. External Reset Circuit:	14
4.5.2. Internal Reset Circuit:	15
4.5.3. External LPO Input Circuit	Error! Bookmark not defined.
5. Regulatory Compliance	16
5.1. Modular Approval, FCC and IC	17
5.2. FCC Label Instructions	17
5.3. CE Certification	17
5.4. Bluetooth Certification	17
5.5. Brazil Certification and Label Instructions	17
5.6. Japan MIC Certification	18
6. Version Comparison Guide	18
7. Ordering Information	18
8. Revision History	19

1. Software Architecture

1.1. Lower Layer Stack

- Bluetooth v5.0
- Device power modes: active, sleep and deep sleep
- Wake on Bluetooth feature optimized power consumption of host CPU
- Authentication and encryption
- Encryption key length from 8 to 128 bits
- Persistent FLASH memory for BD Address and user parameter storage
- All ACL packet types.
- eSCO packet types: 2-EV3, 2-EV5, 3-EV3, 3-EV5
- Point to multipoint and scatternet support: 3 master and 7 slave links allowed (10 active links simultaneously)
- Sniff, and hold modes: fully supported to maximum allowed intervals
- Master slave switch, supported during connection and post connection
- Dedicated Inquiry Access Code, for improved inquiry scan performance
- Dynamic packet selection, channel quality driven data rate to optimize link performance
- Dynamic power control
- Bluetooth test modes per Bluetooth specification
- 802.11b/g/n co-existence: AFH
- Vendor specific HCI commands to support device configuration and certification test modes

1.2. Upper Layer Stack: Amp'ed UP Lite

- SPP and IAP protocols
- RFCOMM, SDP, and L2CAP supported

1.3. HCI Interface

- Bluetooth v5.0 specification compliant
- HCI UART transport layer (H4)

1.4. AT Command Set: abSerial

- Please see *abSerial Reference Guide* for details

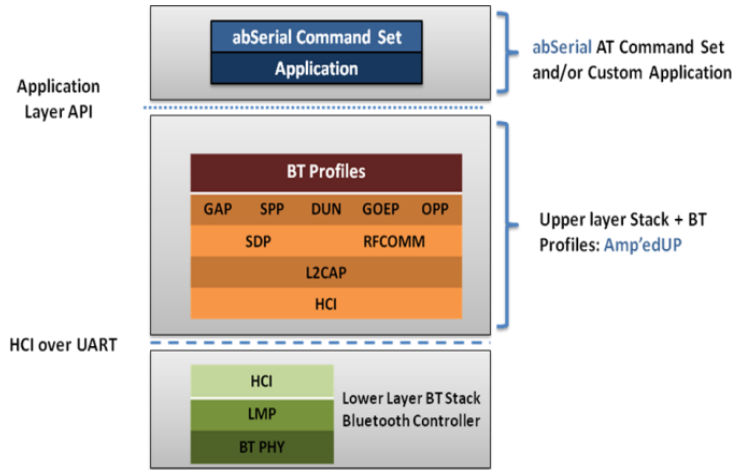

2. Hardware Specifications

General Conditions (V_{IN} = 3.3V and 25°C)

2.1. Recommended Operating Conditions

Rating	Min	Typical	Max	Unit
Operating Temperature Range	-40	-	+85	°C
Supply Voltage V_{IN}	3.0	3.3	3.6	Volts
Signal Pin Voltage	-	3.3	-	Volts
I_{VDDIO}	-	-	60	mA
RF Frequency	2400	-	2483.5	MHz

2.2. Absolute Maximum Ratings

Rating	Min	Typical	Max	Unit
Storage temperature range	-55	-	+125	°C
Supply voltage V_{IN}	-0.3	-	+4.5	Volts
I/O pin voltage V_{IO}	-0.3	-	+4.5	Volts
RF input power	-	-	-5	dBm

2.3. Current Consumption

CPU speed, 64 MHz			
Modes (Typical Power Consumption)	Avg	Unit	
ACL data 115K Baud UART at max throughput (Master)	11.7	mA	
ACL data 115K Baud UART at max throughput (Slave)	12.9	mA	
Connection, no data traffic, master	10.6	mA	
Connection, no data traffic, slave	12.6	mA	

2.4. Selected RF Characteristics

Basic Data Rate

Parameters	Conditions	Typical	Unit
Antenna load		50	ohm
Radio Receiver			
Sensitivity level	BER < .001 with DH5	-92	dBm
Radio Transmitter			
Maximum output power	50 Ω load	+6	dBm
20 dB Bandwidth for modulated carrier		0.95	MHz

2.5. I/O Operating Characteristics

Symbol	Parameter	Min	Max	Unit	Conditions
V _{IL}	Low-Level Input Voltage	-0.3	0.3*VDDIO	Volts	VDDIO=3.3V
V _{IH}	High-Level Input Voltage	0.7*VDDIO	VDDIO+0.3	Volts	VDDIO=3.3V
V _{OL}	Low-Level Output Voltage	-	0.33	Volts	VDDIO=3.3V
V _{OH}	High-Level Output Voltage	2.7	-	Volts	VDDIO=3.3V
I _{OL}	Low –Level Output Current	-	4.0/8.0	mA	V _{OL} = 0.33 V
I _{OH}	High-Level Output Current	-	4.0/8.0	mA	V _{OH} = 3.3V

2.6. Pin Assignment

BT24J

Name	Type	Pin #	Description	ALT Function	5V Tolerant	Initial state
UART Interface						
RXD	I	8	Receive data		3.3V max	
TXD	O	6	Transmit data		3.3V max	
CTS	I	9	Clear to send (active low)		3.3V max	
RTS	O	10	Request to send (active low)		3.3V max	
Power and Ground						
USB_DP	I/O	4	Data Plus		3.3V max	Pull down
USB_DM	I/O	5	Data minus		3.3V max	Pull down
USB						
VDD		22	VDD		3.6V max	
GND		21	GND			
Reset						
RESETN	I	3	Long Press Reset (active low for 1 s);		3.3V max	Pull up
GPIO						
GPIO [15]	I/O	1	General Purpose Input/Output		Y	Pull Up
GPIO [7]	I/O	11	General Purpose Input/Output	I2C_SCL	3.3V max	Pull Up
GPIO [8]	I/O	12	General Purpose Input/Output	I2C_SDA	3.3V max	Pull Up
GPIO [5]	I/O	14	General Purpose Input/Output		3.3V max	Pull Up
GPIO [6]	I/O	15	General Purpose Input/Output		3.3V max	Pull Up
GPIO [14]	O	16	0:Not connected 1:Connection		3.3V max	Pull Down
GPIO [17]	O	17	1: Run Status		Y	Pull Up
GPIO [16]	I/O	18	General Purpose Input/Output		3.3V max	Pull Up
GPIO [11]	I/O	20	General Purpose Input/Output	ADC	3.3V max	Pull Up
NC						
NC		2				
NC		7				
NC		13				
NC		19				

Internal Resistor Characteristics, Internal pull-up/pull-down resistance accuracy $\pm 20\%$.

Port	Drive Strength	Pull-Up Resistor	Pull-Down Resistor
GPIO,UART	8 mA	10K	10K
USB_DP	4 mA	1.5K	15K
USB_DM	4 mA	180K	15K

2.7. Layout Drawing

Size: 15.2 mm x 20.8 mm x 2.75 mm (Height)

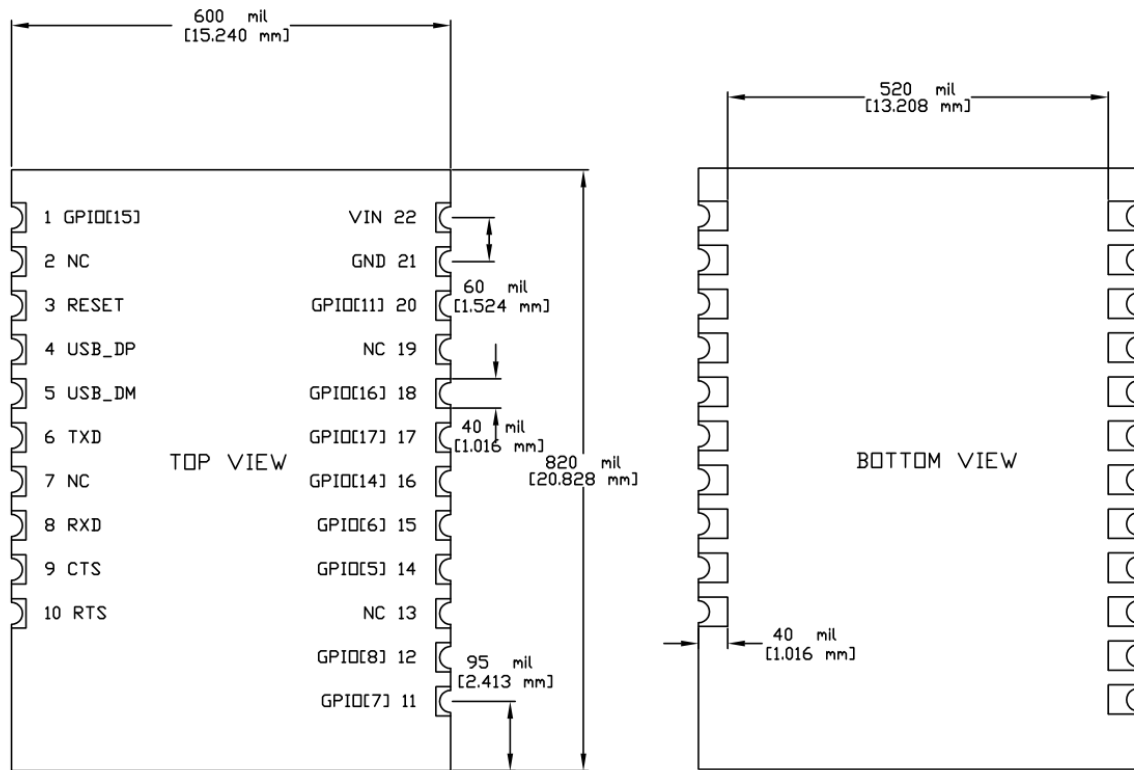

BT24J

3. Module Block Diagram

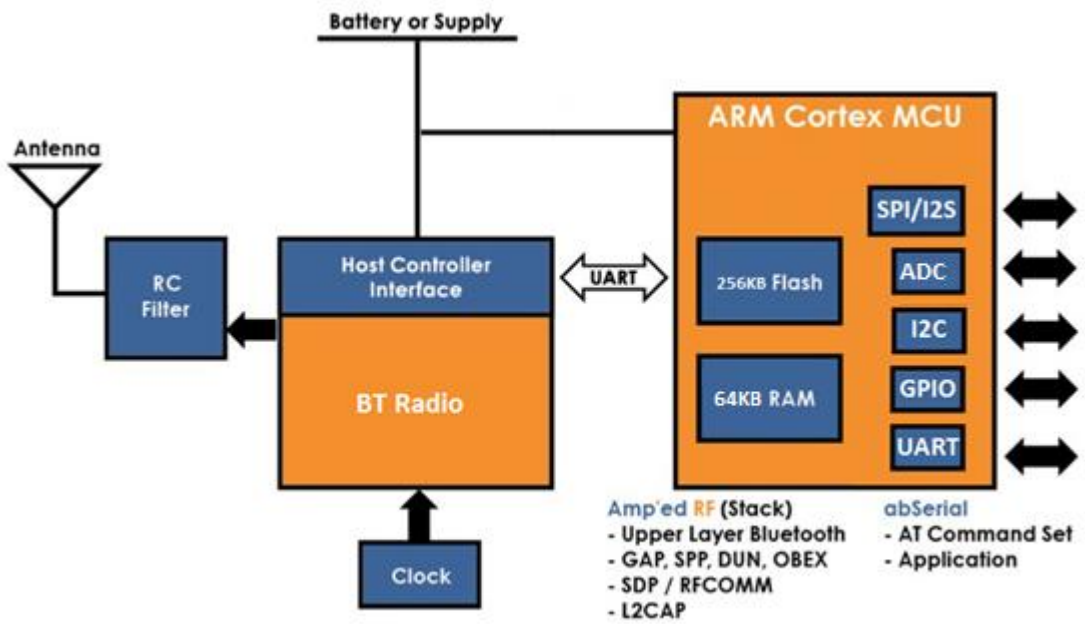

BT24H

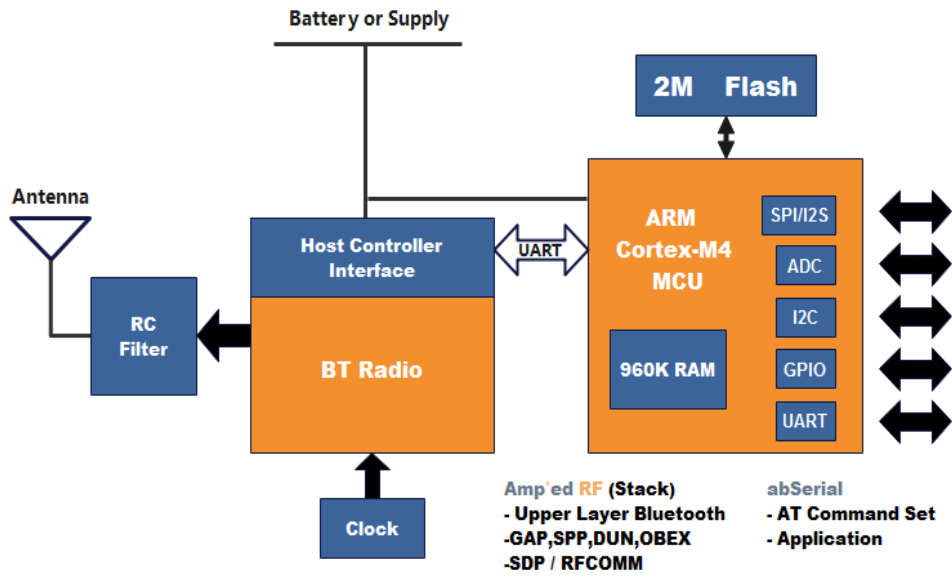

BT24B

4. Hardware Design

Amp'ed RF modules support UART, I2C, SPI, and GPIO hardware interfaces. Please note that the usage of these interfaces is dependent upon the firmware that is loaded into the module, and is beyond the scope of this document. The AT command interface uses the main UART by default.

Notes

- All unused pins should be left floating; do not ground.
- All GND pins must be well grounded.
- The area around the antenna should be free of any ground planes, power planes, trace routings, or metal for at least 6 mm in all directions.
- Traces should not be routed underneath the module.

4.1. Module Reflow Installation

The BT24 is a surface mount Bluetooth module supplied on a 22 pin, 4-layer PCB. The final assembly recommended reflow profiles are:

For RoHS/Pb-free applications, Sn96.5/Ag3.0/Cu0.5 solder is recommended.

- Maximum peak temperature of 230° - 240°C (below 250°C).
- Maximum rise and fall slope after liquidous of < 2°C/second.
- Maximum rise and fall slope after liquidous of < 3°C/second.
- Maximum time at liquidous of 40 – 80 seconds.

4.2. GPIO Interface

All GPIOs are capable of sinking and sourcing 8mA of I/O current.

4.3. UART Interface

The UART is compatible with the 16550 industry standard. Four signals are provided with the UART interface. The TXD and RXD pins are used for data while the CTS and RTS pins are used for flow control.

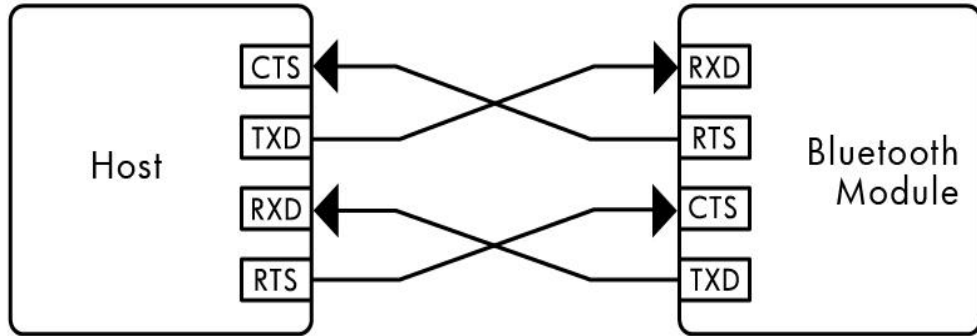

Connection to Host Device

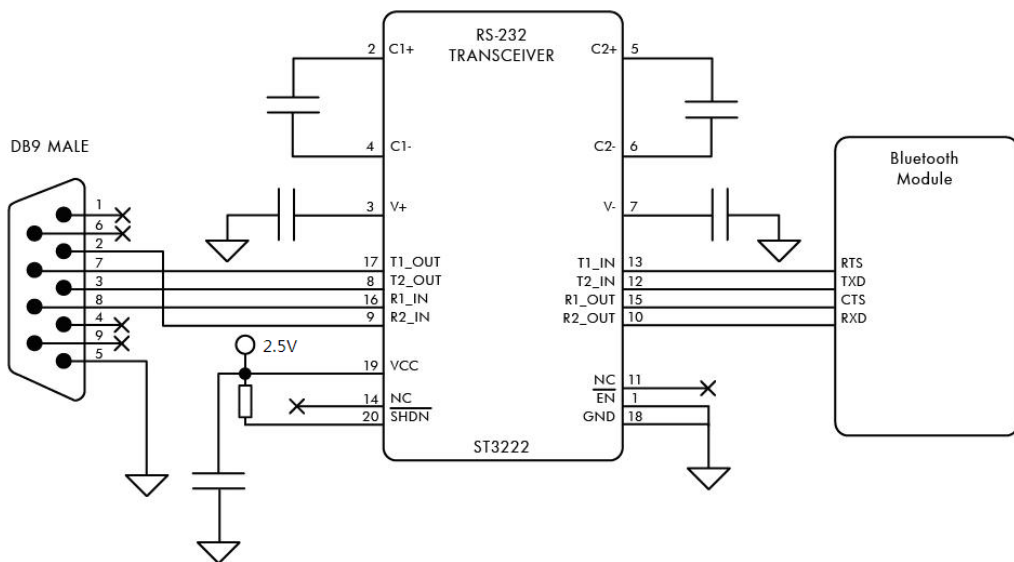

Typical RS232 Circuit

4.4. PCB Layout Guidelines

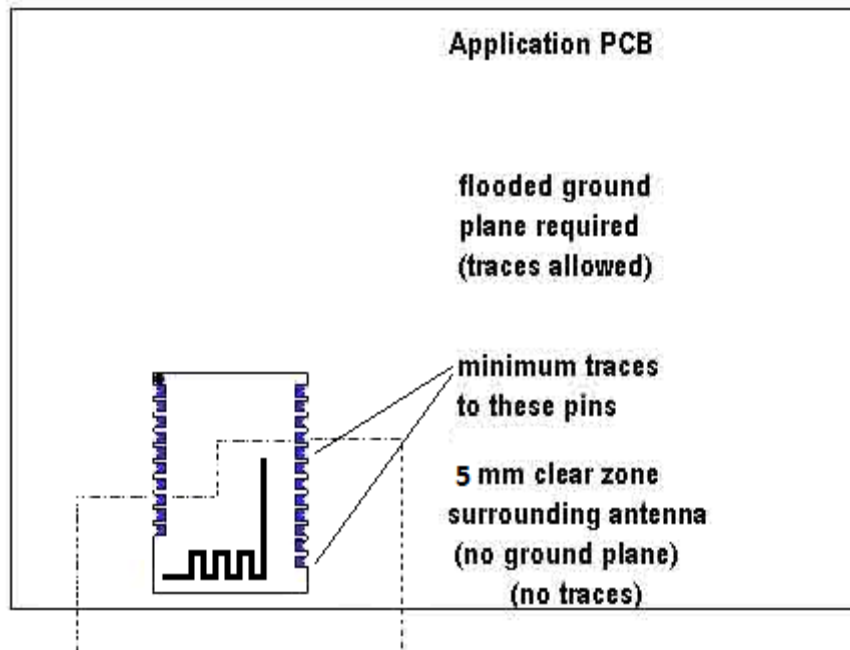

4.5. Reset Circuit

It is a long-press reset, with an internal default 10K pull-up resistor. If don't need to controlled RESET, leave the RESET pin floating; If the chip needs to be reset through RESET pin, it is necessary to ensure that the RESET is pulled down:

- 1 second for the BT24J
- 10ms for the BT24H and BT24B

Two types of system reset circuits are detailed below.

4.5.1. External Reset Circuit:

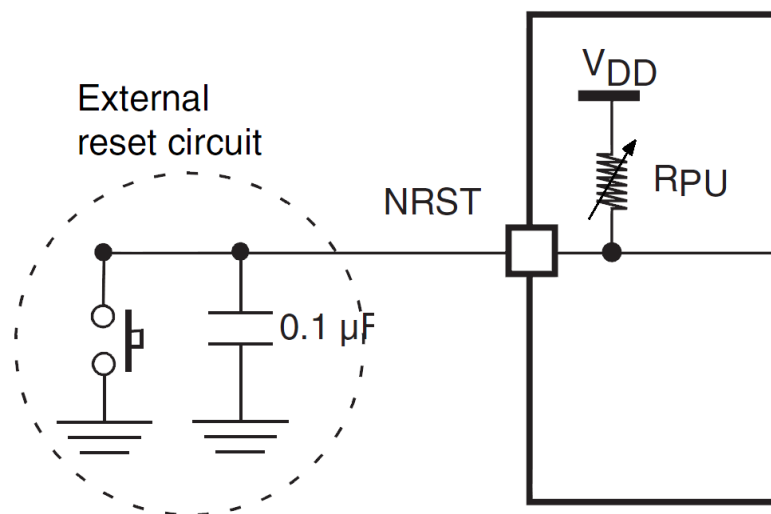

4.5.2. Internal Reset Circuit:

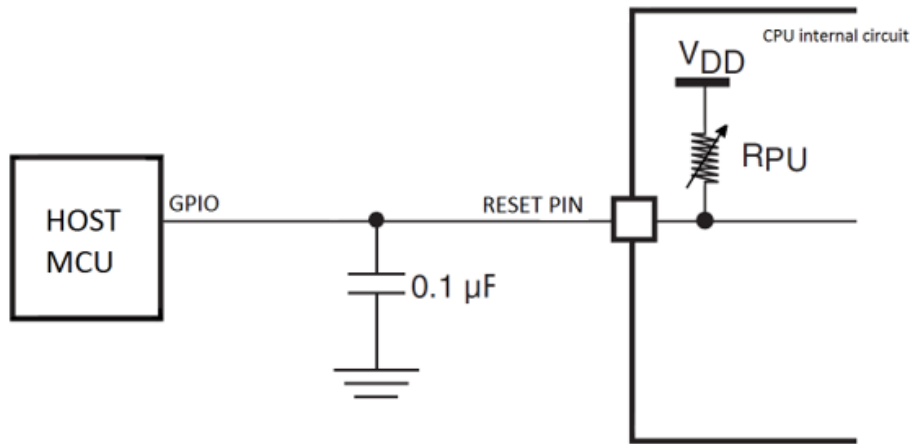

5. Regulatory Compliance

Federal Communications Commission statement:

This module has been tested and found to comply with the FCC Part15.

These limits are designed to provide reasonable protection against harmful interference in approved installations. This equipment generates, uses, and can radiate radio frequency energy and, if not installed and used in accordance the instructions, may cause harmful interference to radio communications. However, there is no guarantee that interference will not occur in a particular installation.

This device complies with part 15 of the FCC Rules. Operation is subject to the following two conditions: (1) This device may not cause harmful interference, and (2) this device must accept any interference received, including interference that may cause undesired operation.

Modifications or changes to this equipment not expressly approved by Amp'ed RF Technology may void the user's authority to operate this equipment.

The modular transmitter must be equipped with either a permanently affixed label or must be capable of electronically displaying its FCC identification number

(A) If using a permanently affixed label, the modular transmitter must be labeled with its own FCC identification number, and, if the FCC identification number is not visible when the module is installed inside another device, then the outside of the device into which the module is installed must also display a label referring to the enclosed module. This exterior label can use wording such as the following: "Contains Transmitter Module FCC ID: X3ZBTMOD11" or "Contains FCC ID: X3ZBTMOD11."

(B) If the modular transmitter uses an electronic display of the FCC identification number, the information must be readily accessible and visible on the modular transmitter or on the device in which it is installed. If the module is installed inside another device, then the outside of the device into which the module is installed must display a label referring to the enclosed module. This exterior label can use wording such as the following: "Contains FCC certified transmitter module(s)."

To satisfy FCC RF Exposure requirements for mobile and base station transmission devices, a separation distance of 20 cm or more should be maintained between the antenna of this device and persons during operation. To ensure compliance, operation at closer than this distance is not recommended. The antenna(s) used for this transmitter must not be co-located or operating in conjunction with any other antenna or transmitter.

Industry Canada statement:

Label of the end product:

The final end product must be labeled in a visible area with the following "Contains transmitter module IC: 8828A-MOD11"

This Class B digital apparatus complies with Canadian ICES-003.

Cet appareil numérique de la classe B est conforme à la norme NMB-003 du Canada.

This device complies with RSS-210 of the Industry Canada Rules. Operation is subject to the following two conditions: (1) This device may not cause harmful interference, and (2) this device must accept any interference received, including interference that may cause undesired operation.

Ce dispositif est conforme à la norme CNR-210 d'Industrie Canada applicable aux appareils radio exempts de licence. Son fonctionnement est sujet aux deux conditions suivantes: (1) le dispositif ne doit pas produire de brouillage préjudiciable, et (2) ce dispositif doit accepter tout brouillage reçu, y compris un brouillage susceptible de provoquer un fonctionnement indésirable.

5.1. Modular Approval, FCC and IC

FCC ID: X3ZBTMOD11

IC: 30534-MOD11

In accordance with FCC Part 15, the BT24 is listed above as a Limited Modular Transmitter device.

5.2. FCC Label Instructions

The outside of final products that contain a BT24 device must display a label referring to the enclosed module. This exterior label can use wording such as the following:

Contains Transmitter Module

FCC ID: X3ZBTMOD11

IC: 30534-MOD11

Any similar wording that expresses the same meaning may be used.

5.3. CE Certification

EN 300 328 v2.2.2

EN IEC 62311:2020

5.4. Bluetooth Certification

Bluetooth QDID: B064073

5.5. Brazil Certification and Label Instructions

The BT24 device has ANATEL approval: 02998-18-11214.

The outside of final products that contain a BT24H device must display the following:



Este equipamento não tem direito à proteção contra interferência prejudicial e não pode causar interferência em sistemas devidamente autorizados

5.6. Japan MIC Certification

The BT24 device has MIC approval:

Certificate Number: CER173795

Certification Number: R 218-230077

6. Version Comparison Guide

Features	BT24P	BT24H	BT24B	BT24J
BT Profiles	SPP, IAP	A2DP, AVRCP, HFP ,HID, SPP, IAP	A2DP, AVRCP, HFP ,HID, SPP, IAP,ATT,GATT	SPP,SMP,ATT,GATT,
RAM Memory	16K	64K	960K	70K
ROM Memory	128K	256K	2M	512K
CPU Speed	36MHz	84MHz	240MHz	96MHz
GPIO	9	13	13	9
ADC pins	1	1	1	1
DAC pins	0	0	2	0
AT Command	abSerial Lite	abSerial Lite	abSerial Lite	abSerial Lite
Shield	No	Yes	Yes	Yes

7. Ordering Information

Part Name	Description
BT24P	Pico version
BT24H	High Performance version
BT24H-C	High Performance version, with alternative MCU option. Same specifications as BT24H.
BT24B	Dual mode with audio.
BT24J	Dual mode.

8. Revision History

Data	Revision	Description
01 June, 2012	1.0	First release
11 Nov, 2012	1.1	Updated FCC and IC certifications
19 Nov, 2012	1.2	Added BT24A information Updated Pin assignment; Reference circuit
06 Mar, 2013	1.3	Added BT24P information
14 May, 2013	1.4	Updated reference designs
09 April, 2014	1.5	Added BT24H information
08 Jan, 2015	1.6	Updated BT24P and LT memory sizes. Added CE information.
23 July, 2015	1.7	Updated section 4.7
12 Oct, 2015	1.8	Removed BT24A, added the shield information.
29 May, 2018	1.9	Added Brazil Anatel regulatory approval.
03 Dec, 2021	1.91	Add BT24H-C part number. Updated CE certification.
12 Oct, 2022	2.0	Add diagrams for BT24B part number.
26 Feb, 2023	2.01	Updated regulatory certifications
29, March, 2023	2.02	Updated IC regulatory ID
13, April, 2026	3.00	Added BT24J dual mode module