

REVISIONS				
P	LTR	DESCRIPTION	DATE	APVD
A		GTP PER ECN-25-338513	17AUG2025	ED WZ

MATERIALS AND PLATING		UNIT: MICRO-INCHES
PART NAME	MATERIAL	PLATING
BODY/SHELL	LOW LEAD BRASS	GOLD 3u"/NICKEL 50u"/COPPER 50u"
CONTACT PIN	LOW LEAD BRASS	GOLD 3u"/NICKEL 50u"/COPPER 50u"
INSULATOR	PTFE ASTM-D-1710	NATURAL
RETAINER RING	LOW LEAD BeCu	NICKEL 100u"/COPPER 50u"
GASKET	SILICONE RUBBER	RED
FERRULE	COPPER(LOW LEAD)	GOLD 3u"/NICKEL 50u"/COPPER 50u"

ELECTRICAL CHARACTERISTICS	
IMPEDANCE	50 Ω
VOLTAGE RATING	335 V(rms)
FREQUENCY RANGE	DC~8 GHz
DIELECTRIC WITHSTANDING VOLTAGE	>1000 V
CONTACT RESISTANCE	CENTER CONTACT <3.0 mΩ
	OUTER CONTACT <2.0 mΩ
INSULATION RESISTANCE	>5000 MΩ
INSERTION LOSS	N/A
VSWR	<1.30
3RD INTERMODULATION	N/A

MECHANICAL CHARACTERISTICS	
DURABILITY	> 500 cycles

ENVIRONMENTAL PARAMETER	
TEMPERATURE RANGE	-65 °C~+165 °C
WATERPROOF	/
THERMAL SHOCK	MIL- STD 202, Meth. 107,Cond. B
VIBRATION	MIL- STD 202, Meth. 204,Cond. D
SHOCK	MIL- STD 202, Meth. 213,Cond. I
CORROSION	MIL- STD 202, Meth. 101,Cond. B

NOTES:
 1 BAG PACKAGING;
 2 ALL DIMENSIONS ARE NOMINAL FOR REFERENCE ONLY UNLESS OTHERWISE STATED.

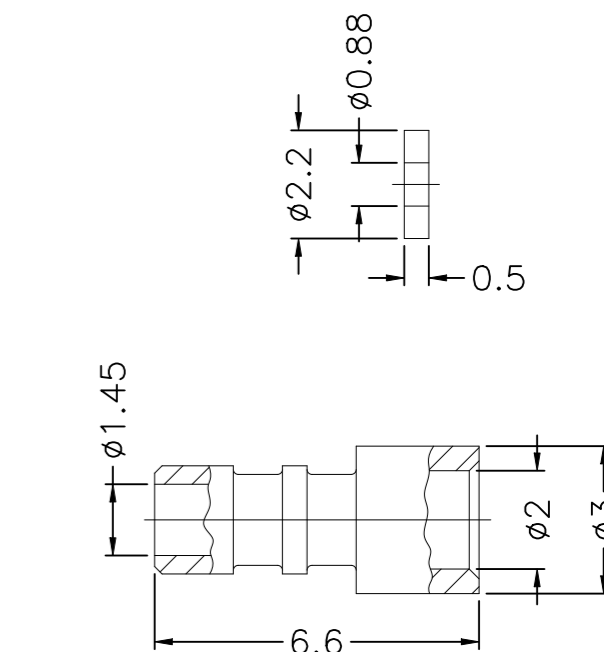
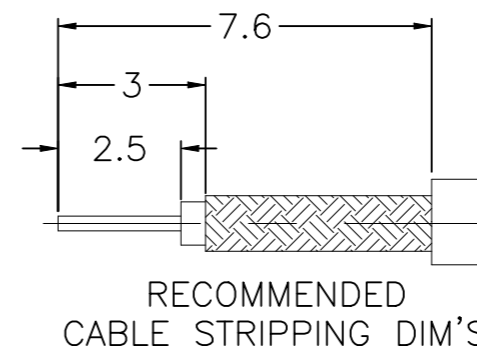
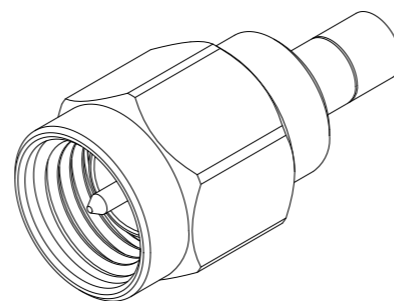
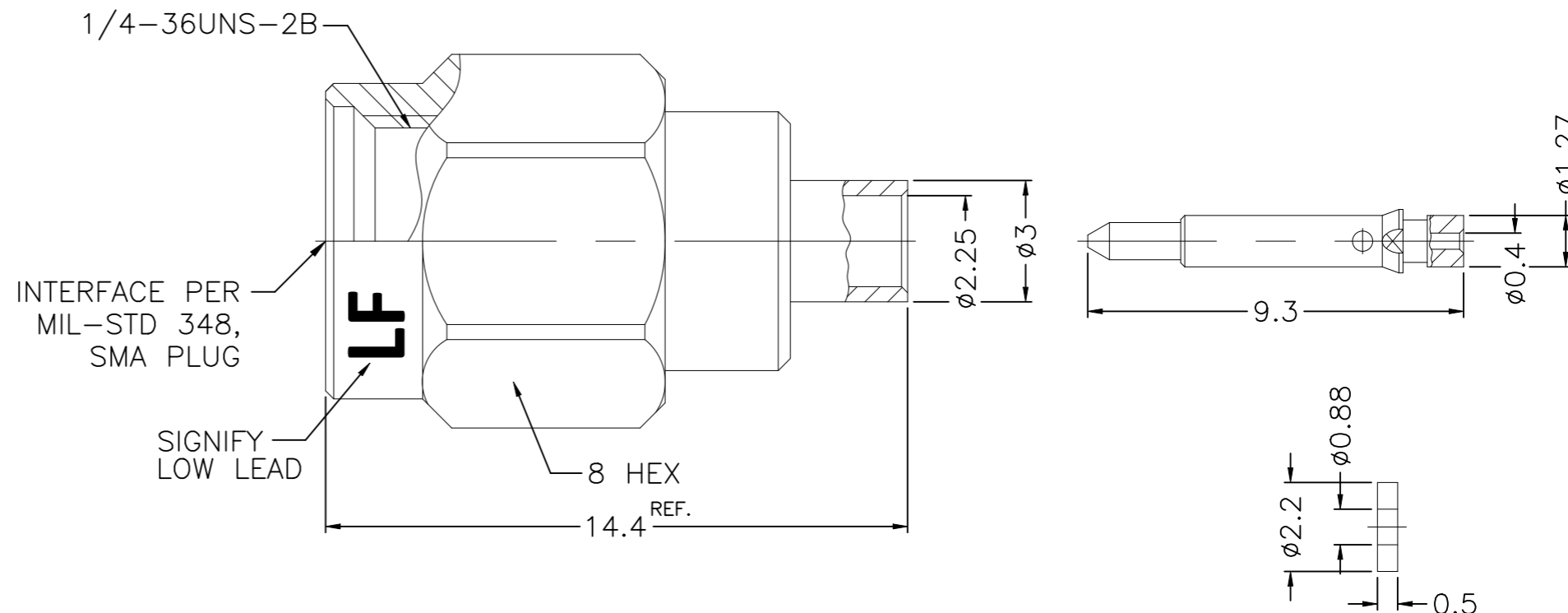

1. CRIMPED FERRULE
HEX CRIMP SIZE .1"
2. CONTACT PIN TO SOLDER

LOW LEAD VERSION,RoHS (Pb < 100ppm),REACH	2508876-1
MARK	PART NUMBER

THIS DRAWING IS A CONTROLLED DOCUMENT.		DWN ED 16JUN2025	STE TE Connectivity			
		CHK TP 16JUN2025				
		APVD WH 16JUN2025	NAME			
		PRODUCT SPEC	SMA Plug Str Crimp RG-178, 196 Lead Free			
		APPLICATION SPEC				
		WEIGHT 0	SIZE A3	CAGE CODE 00779	DRAWING NO C-2508876	RESTRICTED TO
		CUSTOMER DRAWING	SCALE 1:1	SHEET 1 OF 1	REV A	