

Data Sheet | Item Number: 254-553

PCB terminal block; 2.5 mm²; Pin spacing 7.5/7.62 mm; 3-pole; PUSH WIRE®; gray

<https://www.wago.com/254-553>

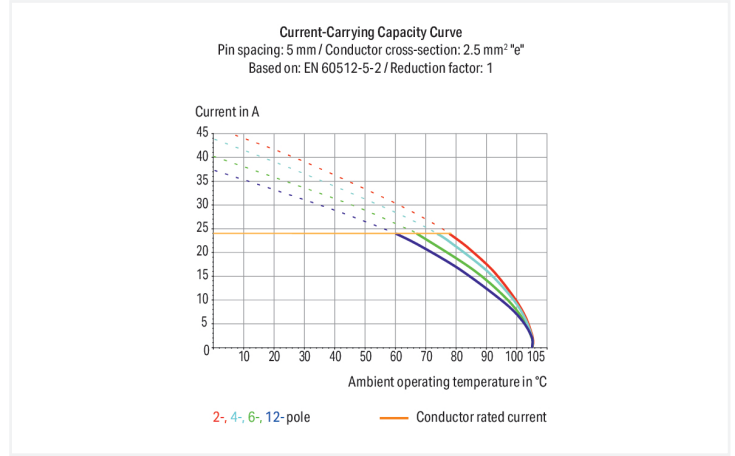

Color: ■ gray

Similar to illustration

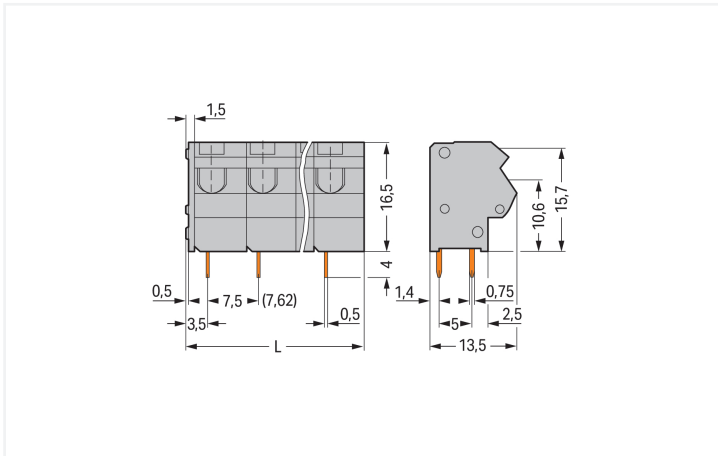

Dimensions in mm

L = (pole no. x pin spacing) + 1.5 mm

PCB terminal block, 254 Series, with 7.5 mm pin spacing

Connecting conductors is quick and easy with this PCB terminal block (item number 254-553). You can count on trusted safety with these PCB terminal blocks, perfect for a wide variety of applications when designing your devices. Strip lengths must be between 10 and 12 mm when connecting conductors to this PCB terminal block. Featuring one conductor terminal along with PUSH WIRE®, this connector delivers reliable performance. Our trusted PUSH WIRE® connection offers the fastest method for clamping conductors. It utilizes the conductor's stiffness to overcome the clamping spring's contact force. Dimensions: (24 x 19.7 x 13.5) mm (width x height x depth). Depending on the conductor type, this PCB terminal block is designed for conductor cross sections ranging from 0.5 mm² to 2.5 mm².

The contact surface is coated with tin. This PCB terminal block is operated with an operating tool. The PCB terminal block is designed for THT soldering. Insert the conductor at an angle of 45°..

Notes

| | |
|-----------|---|
| Variants: | Other pole numbers Other colors Mixed-color PCB connector strips Direct marking Versions for Ex i Other versions (or variants) can be requested from WAGO Sales or configured at https://configurator.wago.com/ . |
|-----------|---|

Electrical data

| Ratings per | IEC/EN 60664-1 | | |
|---------------------------------|----------------|-------|--------|
| Overvoltage category | III | III | II |
| Pollution degree | 3 | 2 | 2 |
| Nominal voltage | 500 V | 630 V | 1000 V |
| Rated impulse withstand voltage | 6 kV | 6 kV | 6 kV |
| Rated current | 24 A | 24 A | 24 A |

| Approvals per | UL 1059 | | |
|---------------|---------|---|-------|
| Use group | B | C | D |
| Rated voltage | 300 V | - | 300 V |
| Rated current | 10 A | - | 10 A |

| Approvals per | CSA | | |
|---------------|-------|---|-------|
| Use group | B | C | D |
| Rated voltage | 300 V | - | 300 V |
| Rated current | 10 A | - | 10 A |

Connection Data

| | |
|----------------------------|---|
| Clamping units | 3 |
| Total number of potentials | 3 |
| Number of connection types | 1 |
| Number of levels | 1 |

| Connection 1 | |
|---|---|
| Connection technology | PUSH WIRE® |
| Actuation type | Operating tool |
| Solid conductor | 0.5 ... 2.5 mm ² / 20 ... 12 AWG |
| Fine-stranded conductor; with insulated ferrule | 0.5 ... 1.5 mm ² |
| Fine-stranded conductor; with uninsulated ferrule | 0.5 ... 1.5 mm ² |
| Note (conductor cross-section) | 12 AWG: THHN, THWN |
| Strip length | 10 ... 12 mm / 0.39 ... 0.47 inches |
| Conductor connection direction to PCB | 45° |
| Pole number | 3 |

Physical data

| | |
|-------------------------|--------------------------------|
| Pin spacing | 7.5/7.62 mm / 0.295/0.3 inches |
| Width | 24 mm / 0.945 inches |
| Height | 19.7 mm / 0.776 inches |
| Height from the surface | 15.7 mm / 0.618 inches |
| Depth | 13.5 mm / 0.531 inches |
| Solder pin length | 4 mm |
| Solder pin dimensions | 0.5 x 0.75 mm |
| Drilled hole diameter | 1.1 (+0.1) mm |

PCB contact

| | |
|-------------------------------------|--|
| PCB contact | THT |
| Solder pin arrangement | over the entire terminal strip (in-line) |
| Number of solder pins per potential | 2 |

Material data

| | |
|------------------------------------|--|
| Note (material data) | Information on material specifications can be found here |
| Color | gray |
| Material group | I |
| Insulation material (main housing) | Polyamide (PA66) |
| Flammability class per UL94 | V0 |
| Clamping spring material | Chrome-nickel spring steel (CrNi) |
| Contact material | Electrolytic copper (E _{Cu}) |
| Contact Plating | Tin |
| Fire load | 0.071 MJ |
| Weight | 4.1 g |

Environmental requirements

| | |
|-------------------------|-----------------|
| Limit temperature range | -60 ... +105 °C |
|-------------------------|-----------------|

Commercial data

| | |
|-----------------------|--------------------------------|
| Product Group | 4 (Printed Circuit Connectors) |
| PU (SPU) | 200 (50) pcs |
| Packaging type | Box |
| Country of origin | PL |
| GTIN | 4044918940856 |
| Customs tariff number | 85369010000 |

Product Classification

| | |
|-------------|----------------------|
| UNSPSC | 39121409 |
| eCl@ss 10.0 | 27-44-04-01 |
| eCl@ss 9.0 | 27-44-04-01 |
| ETIM 9.0 | EC002643 |
| ETIM 10.0 | EC002643 |
| ECCN | NO US CLASSIFICATION |

Environmental Product Compliance

| | |
|------------------------|-------------------------|
| RoHS Compliance Status | Compliant, No Exemption |
|------------------------|-------------------------|

Approvals / Certificates

General approvals



| Approval | Standard | Certificate Name |
|---------------------------------|----------|------------------|
| CCA DEKRA Certification B.V. | EN 60947 | NTR NL 7375 |
| CSA CSA Group | C22.2 | 70154033 |

General approvals

| | | |
|---|---------|--------|
| UR Underwriters Laboratories Inc. | UL 1059 | E45172 |
|---|---------|--------|

Approvals for marine applications



| Approval | Standard | Certificate Name |
|---|-----------|-------------------|
| ABS American Bureau of Ship- ping | - | 24-0095975-PDA |
| BV Bureau Veritas S.A. | IEC 60998 | 11915/E0 BV |
| DNV DNV GL SE | - | TAE000016Z |
| PRS Polski Rejestr Statków | - | TE/1095/880590/23 |

Downloads

Environmental Product Compliance

Compliance Search

| | |
|---|---|
| Environmental Product Compliance 254-553 | ↓ |
|---|---|

Documentation

Additional Information

| | | | |
|-------------------|------------|-------------------|---|
| Technical Section | 03.04.2019 | pdf 2027.26 KB | ↓ |
|-------------------|------------|-------------------|---|

CAD/CAE-Data

CAD data

| | |
|----------------------|---|
| 2D/3D Models 254-553 | ↓ |
|----------------------|---|

CAE data

| | |
|------------------------------|---|
| EPLAN Data Portal 254-553 | ↓ |
| ZUKEN Portal 254-553 | ↓ |

PCB Design

| | |
|---|---|
| Symbol and Footprint via SamacSys 254-553 | ↓ |
| Symbol and Footprint via Ultra Librarian 254-553 | ↓ |

1 Compatible Products

1.1 Optional Accessories

1.1.1 Ferrule

1.1.1.1 Ferrule



Item No.: 216-241

Ferrule; Sleeve for 0.5 mm² / 20 AWG; insulated; electro-tin plated; electrolytic copper; gastight crimped; acc. to DIN 46228, Part 4/09.90; white



Item No.: 216-141

Ferrule; Sleeve for 0.5 mm² / 20 AWG; uninsulated; electro-tin plated; electrolytic copper; gastight crimped; acc. to DIN 46228, Part 1/08.92



Item No.: 216-242

Ferrule; Sleeve for 0.75 mm² / 18 AWG; insulated; electro-tin plated; electrolytic copper; gastight crimped; acc. to DIN 46228, Part 4/09.90; gray



Item No.: 216-262

Ferrule; Sleeve for 0.75 mm² / 18 AWG; insulated; electro-tin plated; electrolytic copper; gastight crimped; acc. to DIN 46228, Part 4/09.90; gray



Item No.: 216-142

Ferrule; Sleeve for 0.75 mm² / 18 AWG; uninsulated; electro-tin plated; electrolytic copper; gastight crimped; acc. to DIN 46228, Part 1/08.92



Item No.: 216-243

Ferrule; Sleeve for 1 mm² / AWG 18; insulated; electro-tin plated; electrolytic copper; gastight crimped; acc. to DIN 46228, Part 4/09.90; red



Item No.: 216-263

Ferrule; Sleeve for 1 mm² / AWG 18; insulated; electro-tin plated; electrolytic copper; gastight crimped; acc. to DIN 46228, Part 4/09.90; red



Item No.: 216-143

Ferrule; Sleeve for 1 mm² / AWG 18; uninsulated; electro-tin plated; electrolytic copper; gastight crimped; acc. to DIN 46228, Part 1/08.92



Item No.: 216-244

Ferrule; Sleeve for 1.5 mm² / AWG 16; insulated; electro-tin plated; electrolytic copper; gastight crimped; acc. to DIN 46228, Part 4/09.90; black



Item No.: 216-264

Ferrule; Sleeve for 1.5 mm² / AWG 16; insulated; electro-tin plated; electrolytic copper; gastight crimped; acc. to DIN 46228, Part 4/09.90; black



Item No.: 216-144

Ferrule; Sleeve for 1.5 mm² / AWG 16; uninsulated; electro-tin plated; electrolytic copper; gastight crimped; acc. to DIN 46228, Part 1/08.92; silver-colored

1.1.2 Marking

1.1.2.1 Marking strip



Item No.: 210-332/750-020

Marking strips; as a DIN A4 sheet; MARKED; 1-20 (80x); Height of marker strip: 3 mm; Strip length 182 mm; Horizontal marking; Self-adhesive; white



Item No.: 210-332/762-020

Marking strips; as a DIN A4 sheet; MARKED; 1-20 (80x); Height of marker strip: 3 mm; Strip length 182 mm; Horizontal marking; Self-adhesive; white

1.1.3 Test and measurement

1.1.3.1 Testing accessories



Item No.: 210-136

Test plug; 2 mm Ø; with 500 mm cable; red

1.1.4 Tool

1.1.4.1 Operating tool



Item No.: 210-658

Operating tool; Blade: 3.5 x 0.5 mm; with a partially insulated shaft; angled; short; multicoloured



Item No.: 210-720

Operating tool; Blade: 3.5 x 0.5 mm; with a partially insulated shaft; multicoloured



Item No.: 210-657

Operating tool; Blade: 3.5 x 0.5 mm; with a partially insulated shaft; short; multicoloured

Installation Notes

Conductor termination

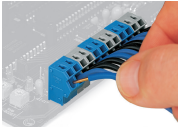

Insert solid conductors via push-in termination.

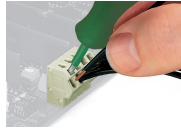

Inserting a tip-bonded conductor via screwdriver.



Removing a solid conductor.

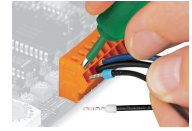

Inserting/removing a ferruled conductor.

Marking

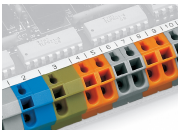

Labeling via self-adhesive marking strips.

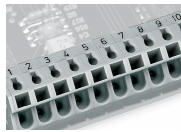

Labeling via factory direct marking.

Testing

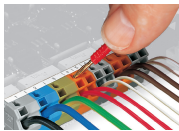

Testing with 2 mm Ø test plug.

Application

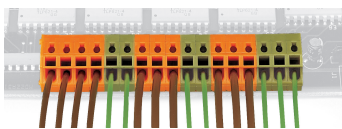

Mixed terminal strips can be assembled using different housing colors for the formation of groups.

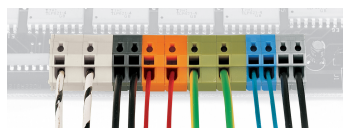

Mixed terminal strips can be assembled using different pin spacing and housing colors for the formation of groups.

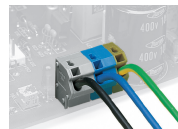

Application example: field-wiring terminal strip