

FEATURES

- ◆ Slip ring measurement peaking
- ◆ High Stiffness
- ◆ Protection IP50
- ◆ High Level Output Model with Integrated Amplifier

APPLICATIONS

- ◆ Dynamic applications
- ◆ Process control equipment
- ◆ Test and Measurement
- ◆ Robotics and effectors
- ◆ Laboratory and Research

CD1095

Dynamic Rotary Torque Sensor

SPECIFICATIONS

- ◆ Range from ± 5 to $\pm 2,500$ Nm (± 4 to 2,000 lbf.ft)
- ◆ Keyed Shaft couplings
- ◆ Stainless Steel
- ◆ Cable Gland or Connector Output

The **CD1095** has been designed to measure in-line torque on rotating shafts. Its sensing element is based on thin layer strain gauges in a Wheatstone bridge configuration providing excellent temperature stability.

Optionally the torque sensor can receive an on-board amplifier for high-level output.

Another version with male square couplings exists under the reference **CD1050**.

With ma long standing experience as a designer and manufacturer of sensors, TE CONNECTIVITY often works with customers to design or customize sensors for specific uses and testing environments.

On request, Instruction documents can be provided to ease the selection and use of our sensors and provide helpful tips.

STANDARD RANGES

Range in Nm (FS)	5 - 10 - 20	50 - 75 - 100	150 - 200 - 300	500 - 750	1k – 1.75k – 2,5k
Range in lbf.ft (FS)	4 - 8 - 16	40 - 60 - 80	120 - 160 - 240	400 - 600	800 – 1.4k – 2k
Stiffness in Nm/rad	1.4x10 ² to 9x10 ²	9x10 ² to 7.5x10 ³	7.5x10 ³ to 3x10 ⁴	3x10 ⁴ to 1x10 ⁵	1x10 ⁵ to 3.5x10 ⁵
Stiffness in lbf.ft/rad	0.4x10 ² to 0.6x10 ²	0.6x10 ² to 5.1x10 ²	5.1x10 ² to 2.1x10 ³	2.1x10 ³ to 6.9x10 ³	6.9x10 ³ to 2.4x10 ⁴
Rotation in rpm	3000	3000	2200	1750	1250

PERFORMANCE SPECIFICATIONS (typical values at temperature 23±3°)

Parameters	
Operating Temperature Range (OTR)	-20 to 80° C (-4 to 176° F)
Compensated Temperature Range (CTR)	0 to 60° C (32 to 140° F)
Zero Shift in CTR	<0.5% F.S./ 50° C [1/100° F]
Sensitivity Shift in CTR	<1% of reading / 50° C [1/100° F]
Range (F.S.)	±5 Nm to ±2,5 kNm [±4 lbf.ft to ±2 klbf.ft]
Velocity of Rotation	Up to 3000 RPM ; Bidirectional operation
Over-Range	
Save Overload	1.5 x F.S.
Ultimate Load	3 x F.S.
Accuracy	
Combined Non-Linearity & Hysteresis	<±0.25%F.S

Electrical Characteristics

Model	CD1095¹	CD1095-A1	CD1095-A2
Supply Voltage	1 to 10Vdc	10 to 30Vdc	±15Vdc (±12 to ±18Vdc)
Sensitivity “FSO” ²	±2mV/V	±2V ±0.2V	±5V ±0.2V
Zero Offset ²	<±1mV	2.5V ±0.2V	0V ±0.2V
Input Impedance/Consumption	350 to 700Ω	<50mA	<50mA
Output Impedance	350 to 700Ω	1 kΩ ⁶	1 kΩ ⁶
Insulation under 50Vdc	≥100MΩ	≥100MΩ	≥100MΩ

Notes

1. Sensors are calibrated with 10Vdc power supply as standard.
2. Signal goes positive in CW strain with standard wiring configuration. Other signal output on request
3. Electrical Termination: Connector output including mating plug
4. Material: Body in stainless steel ; aluminum alloy housing
5. Connection : Keyed shaft standard, other connection types on request (smooth shaft, cotter pin, etc)
6. Output impedance < 100Ω on request
7. CE conformance according to EN 61010-1, EN 50081-1, EN 50082-1

DIMENSIONS & WIRING SCHEMATIC (IN METRIC AND IMPERIAL)

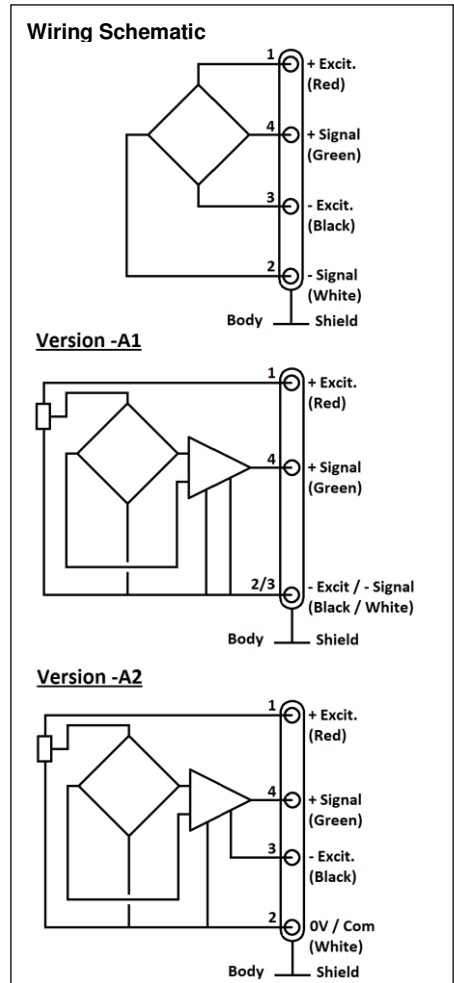
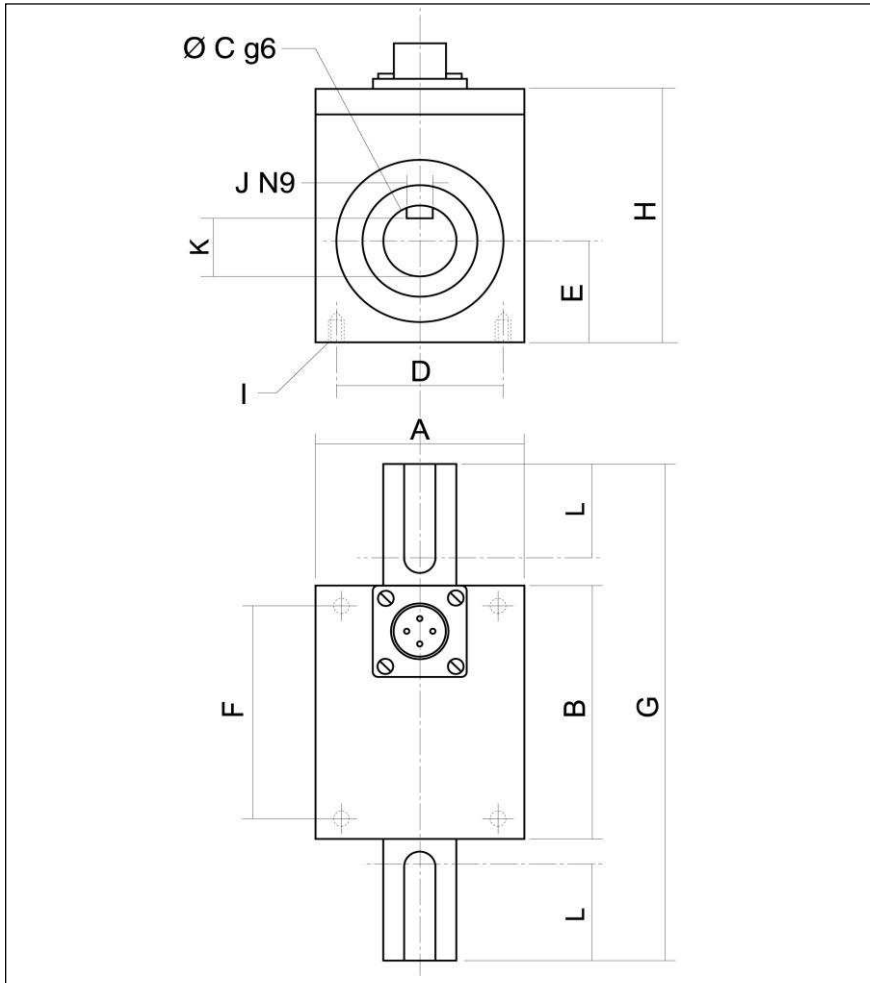

Dimensions in mm [inch]

Range in Nm [lbf.ft]	5 - 10 - 20 [4 - 8 - 16]		50 - 75 - 100 [40 - 60 - 80]		150 - 200 - 300 [120 - 160 - 240]		500 - 750 [400 - 600]		1k - 1,75k - 2,5k [800 - 1,4k - 2k]	
A	40	[1.57]	40	[1.57]	50	[1.97]	60	[2.36]	80	[3.15]
B	50	[1.97]	50	[1.97]	55	[2.17]	60	[2.36]	75	[2.95]
C	14	[0.55]	19	[0.75]	28	[1.10]	39	[1.54]	54	[2.13]
D	32	[1.26]	32	[1.26]	40	[1.57]	50	[1.97]	70	[2.76]
E	20	[0.79]	20	[0.79]	25	[0.98]	30	[1.18]	40	[1.57]
F	42	[1.65]	42	[1.65]	45	[1.77]	50	[1.97]	65	[2.56]
G	90	[3.54]	110	[4.33]	150	[5.91]	180	[7.09]	260	[10.24]
H	50	[1.97]	50	[1.97]	60	[2.36]	70	[2.76]	90	[3.54]
I	4 x M3		4 x M3		4 x M3		4 x M4		4 x M4	
J	5	[0.20]	6	[0.24]	8	[0.31]	12	[0.47]	16	[0.63]
K	11	[0.43]	15.5	[0.61]	24	[0.94]	34	[1.34]	48	[1.89]
L	15	[0.59]	25	[0.98]	40	[1.57]	50	[1.97]	80	[3.15]

CD1095

Dynamic Torquemeter

OPTIONS

A1 : Amplified Tension output with unipolar power supply
A2 : Amplified Tension output with bipolar power supply
V00 : Non-standard power supply calibration, replace "00" with value in Volt (standard 10Vdc, unamplified sensor only)
PE : Cable Gland Termination with 2 m [6.6 ft] cable

ORDERING INFO

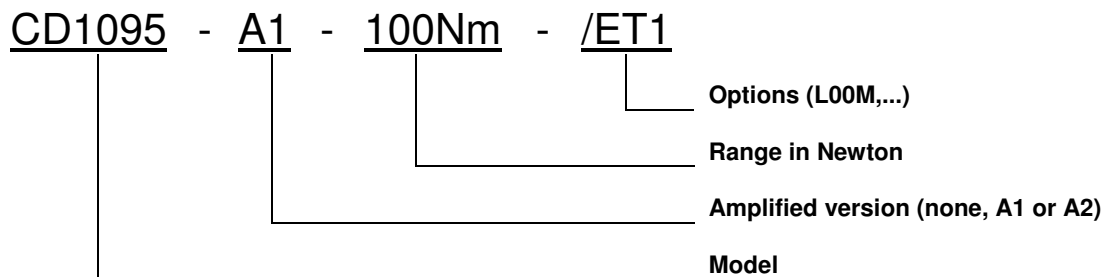

SUPPLIED ACCESSOIRES

EFMX-4M : mating plug Jaeger 530-801-006 with clamp 530-841-006

NORTH AMERICA

Measurement Specialties, Inc.,
a TE Connectivity Company
Phone: +1 800 522 6752
Email: customercare.frm@te.com

EUROPE

Measurement Specialties (Europe), Ltd.
a TE Connectivity Company
Phone: +31 73 624 6999
Email: customercare.lcsb@te.com

ASIA

Measurement Specialties (China), Ltd.,
a TE Connectivity Company
Phone +86 400 820 6015
Email: customercare.shzn@te.com

TE.com/sensorsolutions

Measurement Specialties, Inc., a TE Connectivity company.

Measurement Specialties, TE Connectivity, TE Connectivity (logo) and EVERY CONNECTION COUNTS are trademarks. All other logos, products and/or company names referred to herein might be trademarks of their respective owners.

The information given herein, including drawings, illustrations and schematics which are intended for illustration purposes only, is believed to be reliable. However, TE Connectivity makes no warranties as to its accuracy or completeness and disclaims any liability in connection with its use. TE Connectivity's obligations shall only be as set forth in TE Connectivity's Standard Terms and Conditions of Sale for this product and in no case will TE Connectivity be liable for any incidental, indirect or consequential damages arising out of the sale, resale, use or misuse of the product. Users of TE Connectivity products should make their own evaluation to determine the suitability of each such product for the specific application.

© 2015 TE Connectivity Ltd. family of companies All Rights Reserved.