



NEO-M9V-20B

Multi-mode dead reckoning module

Professional grade

Data sheet



Abstract

This data sheet describes the u-blox NEO-M9V standard precision with multi-mode dead reckoning (MDR) module. NEO-M9V offers ultra-robust meter-level GNSS positioning performance with concurrent reception of up to four GNSS (GPS, GLONASS, BeiDou, Galileo) together with vehicle speed information and integrated 3D sensors in a 12.2 x 16.0 mm package.

Document information

Title	NEO-M9V-20B	
Subtitle	Multi-mode dead reckoning module	
Document type	Data sheet	
Document number	UBX-21029781	
Revision and date	R07	02-Jun-2025
Disclosure restriction	C1-Public	

Product status	Corresponding content status	
Functional sample	Draft	For functional testing. Revised and supplementary data will be published later.
In development / prototype	Objective specification	Target values. Revised and supplementary data will be published later.
Engineering sample	Advance information	Data based on early testing. Revised and supplementary data will be published later.
Initial production	Early production information	Data from product verification. Revised and supplementary data may be published later.
Mass production / End of life	Production information	Document contains the final product specification.

This document applies to the following products:

Product name	Type number	Firmware version	IN/PCN reference	Product status
NEO-M9V	NEO-M9V-20B-00	MDR 2.10	UBX-22001207, UBX-22002823	End of life
NEO-M9V	NEO-M9V-20B-01	MDR 2.16	UBX-22036877	Mass production
NEO-M9V	NEO-M9V-20B-01	MDR 2.16	-	Mass production

u-blox or third parties may hold intellectual property rights in the products, names, logos and designs included in this document. Copying, reproduction, or modification of this document or any part thereof is only permitted with the express written permission of u-blox. Disclosure to third parties is permitted for clearly public documents only.

The information contained herein is provided "as is" and u-blox assumes no liability for its use. No warranty, either express or implied, is given, including but not limited to, with respect to the accuracy, correctness, reliability and fitness for a particular purpose of the information. This document may be revised by u-blox at any time without notice. For the most recent documents and product statuses, visit www.u-blox.com.

Copyright © 2025, u-blox AG.

Contents

Document information.....	2
Contents.....	3
1 Functional description.....	4
1.1 Overview.....	4
1.2 Performance.....	4
1.3 Supported GNSS constellations.....	5
1.4 Supported protocols.....	6
1.5 Firmware features.....	6
1.6 Multi-mode dead reckoning.....	6
2 System description.....	8
2.1 Block diagram.....	8
3 Pin definition.....	9
3.1 Pin assignment.....	9
4 Electrical specifications.....	11
4.1 Absolute maximum ratings.....	11
4.2 Operating conditions.....	11
4.3 Indicative power requirements.....	12
5 Communications interfaces.....	13
5.1 UART.....	13
5.2 SPI.....	13
5.3 I2C.....	14
5.4 USB.....	16
5.5 WT (wheel tick) and DIR (forward/reverse indication).....	16
5.6 Default interface settings.....	16
6 Mechanical specifications.....	17
7 Qualifications and approvals.....	19
8 Product handling.....	20
8.1 Packaging.....	20
8.1.1 Reels.....	20
8.1.2 Tapes.....	20
9 Product marking and ordering information.....	21
9.1 Product marking.....	21
9.2 Product identifiers.....	21
9.3 Ordering codes.....	22
Related documents.....	23
Revision history.....	24
Contact.....	25

1 Functional description

1.1 Overview

NEO-M9V-20B GNSS receiver features the u-blox M9 standard precision GNSS platform with 3D multi-mode dead reckoning (MDR). It provides exceptional sensitivity and acquisition times for all L1 GNSS systems. u-blox M9 receivers are available in different variants to serve automotive and industrial tracking applications, such as navigation, telematics and UAVs.

NEO-M9V-20B is the first u-blox GNSS receiver with untethered (UDR) and automotive dead reckoning (ADR), specially designed for fleet management and micromobility applications. It directly succeeds the u-blox M8 product range, namely NEO-M8U and NEO-M8L.

NEO-M9V-20B grants lifetime access to AssistNow Live Orbits. This premium assistance service does not only offer improved time-to-first-fix, but also improves position accuracy, especially in typical IoT applications with integrated antennas.

u-blox M9 receivers support concurrent reception of four GNSS. The high number of visible satellites allows the receiver to select the best signals. This maximizes the position accuracy, in particular under challenging conditions such as deep urban canyons.

u-blox M9 receivers detect jamming and spoofing events and report them to the host, which allows the system to react to such events. RF design effort for NEO-M9V-20B is reduced, as a SAW filter and an LNA are integrated. Advanced filtering algorithms mitigate the impact of RF interference and jamming, thus enabling the product to operate as intended.

The receiver also provides higher navigation rate and improved security features compared to previous u-blox GNSS generations.

Access to native, high-rate sensor data also enables host applications to make full use of the receiver's assets, including the wake-on-motion functionality that allows to turn off the host and save power until motion is detected by the IMU.

1.2 Performance

Parameter	Specification	
Receiver type	Multi-constellation GNSS standard precision receiver	
Accuracy of time pulse signal	RMS	30 ns
	99%	60 ns
Frequency of time pulse signal	0.25 Hz to 10 MHz (configurable)	
Operational limits ¹	Dynamics	≤ 4 g
	Altitude	80,000 m
	Velocity	500 m/s
Position error during GNSS loss ²	3D Gyro + 3D accelerometer + WT	2 %
	3D Gyro + 3D accelerometer	10 %

¹ Assuming Airborne 4 g platform

² 68% error incurred without GNSS as a percentage of distance of traveled 3000 m, applicable to four-wheel road vehicle

Parameter	Specification	
Max navigation update rate (PVT) ³	Priority navigation mode	50 Hz
	Non-priority navigation mode	5 Hz
	Secondary output	5 Hz
Navigation latency	Priority navigation mode	15 ms
Velocity accuracy ⁴		0.08 m/s
Dynamic attitude accuracy ⁴	Heading	0.3 deg
	Pitch	0.4 deg
	Roll	0.6 deg
Max sensor measurement output rate	Raw	100 Hz
	Calibrated	100 Hz

GNSS		GPS+GLO+GAL+BDS	GPS+GLO	BDS+GLO
Acquisition ⁵	Cold start	24 s	25 s	28 s
	Hot start	2 s	2 s	2 s
	Aided start ⁶	3 s	2 s	3 s
Sensitivity ⁷	Tracking and nav.	-159 dBm	-159 dBm	-159 dBm
	Reacquisition	-158 dBm	-158 dBm	-158 dBm
	Cold start	-147 dBm	-148 dBm	-146 dBm
	Hot start	-159 dBm	-159 dBm	-158 dBm
Position accuracy PVT ⁸	Horizontal	1.5 m	1.7 m	2.5 m
	Vertical	3 m	3.5 m	4.5 m

Table 1: NEO-M9V-20B typical performance in multi-constellation GNSS modes

1.3 Supported GNSS constellations

NEO-M9V-20B is a concurrent GNSS receiver which can receive and track multiple GNSS systems. The NEO-M9V-20B receiver can be configured for concurrent GPS, GLONASS, Galileo and BeiDou plus SBAS and QZSS reception. If power consumption is a key factor, then the receiver can be configured for a subset of GNSS constellations.

Supported GNSS systems and their signals are:

GPS / QZSS	GLONASS	Galileo	BeiDou
L1C/A (1575.42 MHz)	L1OF (1602 MHz + k*562.5 kHz, k = -7,..., 5, 6)	E1-B/C (1575.42 MHz)	B1I (1561.098 MHz)

Table 2: Supported GNSS systems and signals

The following GNSS assistance services can be activated:

AssistNow™ Live Orbits	AssistNow™ Predictive Orbits	AssistNow™ Autonomous
Supported	Not supported	Not supported

Table 3: Supported assisted GNSS (A-GNSS) services

³ Rates with SBAS and QZSS enabled for > 98% fix report rate under typical conditions

⁴ 68% at 30 m/s for dynamic operation

⁵ Commanded starts. All satellites at -130 dBm. GPS always in combination with QZSS and SBAS. Measured at room temperature.

⁶ Dependent on the speed and latency of the aiding data connection, commanded starts.

⁷ Demonstrated with a good external LNA. Measured at room temperature.

⁸ CEP, 50%, open sky with SBAS and QZSS enabled, -130 dBm, > 6 SVs

NEO-M9V-20B supports the following augmentation systems:

SBAS	QZSS	IMES	Differential GNSS
EGNOS, GAGAN, MSAS and WAAS supported	L1S supported	Not supported	Not supported

Table 4: Supported augmentation systems



The SBAS and QZSS augmentation systems can be enabled only if GPS operation is also enabled.

1.4 Supported protocols

NEO-M9V-20B supports the following protocols:

Protocol	Type
UBX	Input/output, binary, u-blox proprietary
NMEA 4.11 (default), 4.10, 4.0, 2.3, and 2.1	Input/output, ASCII

Table 5: Supported protocols

For specification of the protocols, see the Interface description [2].

1.5 Firmware features

Feature	Description
Advanced calibration handling	Calibration information can be stored with the host
Assisted GNSS	AssistNow Live Orbits lifetime access
Automotive dead reckoning	Combines satellite and sensor-based navigation (IMU and odometer input)
Automatic alignment	Automatic estimation of the alignment angles (automotive dynamic model only)
Backup modes	Hardware backup mode, software backup mode
Dual output	GNSS only and Fused (GNSS+DR) output
Geofencing	Up to 4 circular areas
Odometer	Measure traveled distance with support for different user profiles
Untethered dead reckoning	Combines satellite and sensor-based navigation (IMU)
Upgradeable firmware	Firmware in flash memory can be upgraded
Wake on motion	Wakes up the receiver and the host while the receiver is in SW backup mode
Weak signal compensation	Improves position and speed accuracy with low signal levels

Table 6: Firmware features

Feature	Description
Anti-jamming	RF interference and jamming detection and reporting
Anti-spoofing	Spoofing detection and reporting
Configuration lockdown	Receiver configuration can be locked by command
Message integrity	All messages signed with SHA-256
Secure boot	Only signed FW images executed

Table 7: Security features

1.6 Multi-mode dead reckoning

u-blox's proprietary multi-mode dead reckoning (MDR) consists of two operating modes: untethered dead reckoning (UDR) and automotive dead reckoning (ADR). UDR is based on sensor fusion dead reckoning (SFDR) technology, which combines multi-constellation GNSS measurements with the NEO-M9V-20B's internal 6-axis IMU only. ADR is based on SFDR technology which combines multi-

constellation GNSS measurements with the NEO-M9V-20B's internal 6-axis IMU and wheel tick or speed.

The module has ready-to-use UDR and it can perform advanced ADR when speed pulses from the vehicle's wheel tick (WT) sensor are provided. Alternatively, the vehicle speed data can be provided as messages via a serial interface.

Sensor data and GNSS signals are processed together, achieving 100% coverage, with highly accurate and continuous positioning even in GNSS-hostile environments (for example, urban canyons) or in case of GNSS signal absence (for example, tunnels and parking garages).

 For more details, see the Integration manual [1].

NEO-M9V-20B combines GNSS and dead reckoning measurements and computes a position solution at rates of up to 50 Hz in the priority navigation mode.

 The priority navigation mode works optimally when the IMU and WT sensors have been calibrated, and the alignment angles have been configured correctly.

Dead reckoning allows navigation to commence as soon as power is applied to the module (that is, before a GNSS fix has been established) under the following conditions:

- The vehicle has not been moved while the module has been switched off.
- At least a dead reckoning fix was available when the vehicle was last used.
- A backup supply has been available for the module since the vehicle was last used.

 The save-on-shutdown feature can be used when no backup supply is available. All necessary information is saved to the flash and read from the flash upon restart.

 The advanced calibration handling feature can be used when no backup supply is available or the save-on-shutdown feature cannot be used. This feature allows the host to poll and later send the sensor initialization and calibration parameters to the receiver.

2 System description

2.1 Block diagram

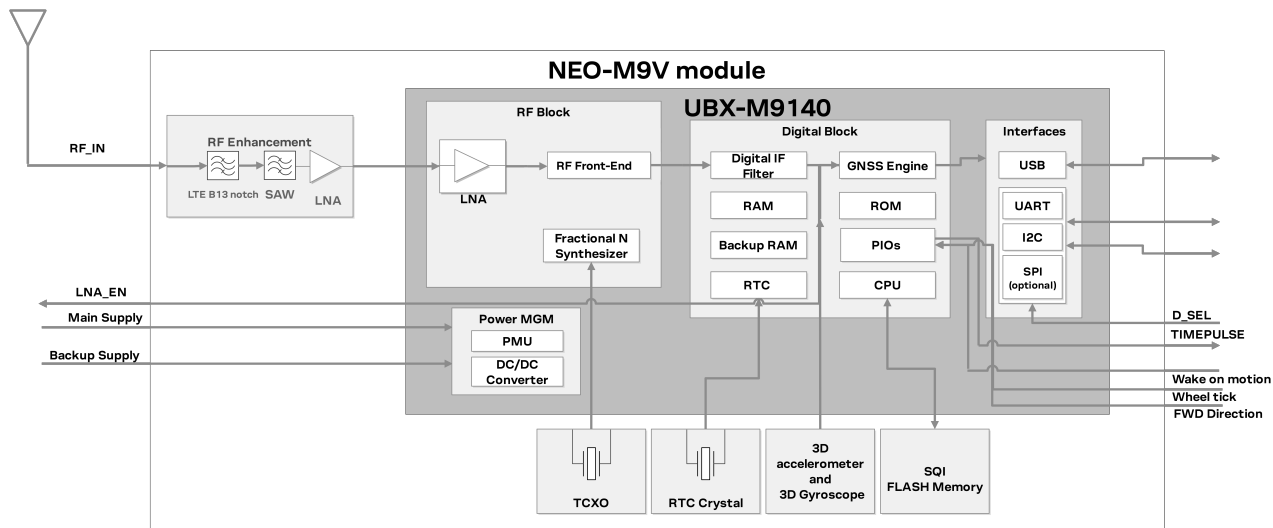

Figure 1: NEO-M9V-20B block diagram

3 Pin definition

3.1 Pin assignment

The pin assignment of the NEO-M9V-20B module is shown in [Figure 2](#). The defined configuration of the PIOs is listed in [Table 8](#).

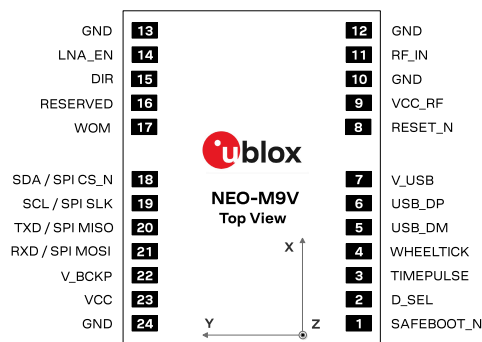

Figure 2: NEO-M9V-20B pin assignment

Pin no.	Name	I/O	Description
1	SAFEBOOT_N	I	SAFEBOOT_N (used for FW updates and reconfiguration, leave open) ⁹
2	D_SEL	I	Interface select (open or VCC = UART + I2C; GND = SPI)
3	TIMEPULSE	O	TIMEPULSE (1 PPS, TP2) ⁹
4	WHEELTICK	I	Wheel-tick input
5	USB_DM	I/O	USB data (DM)
6	USB_DP	I/O	USB data (DP)
7	V_USB	I	USB supply
8	RESET_N	I	RESET (active low)
9	VCC_RF	O	Voltage for external LNA
10	GND	I	Ground
11	RF_IN	I	GNSS signal input
12	GND	I	Ground
13	GND	I	Ground
14	LNA_EN	O	Antenna/LNA control
15	DIR	I	Direction input for speed pulse
16	Reserved	-	Reserved
17	WOM	O	Wake on motion interrupt
18	SDA / SPI CS_N	I/O	I2C data if D_SEL = VCC (or open); SPI chip select if D_SEL = GND
19	SCL / SPI SLK	I/O	I2C clock if D_SEL = VCC (or open); SPI clock if D_SEL = GND
20	TXD / SPI SDO	O	UART output if D_SEL = VCC (or open); SPI SDO if D_SEL = GND
21	RXD / SPI SDI	I	UART input if D_SEL = VCC (or open); SPI SDI if D_SEL = GND
22	V_BCKP	I	Backup voltage supply

⁹ The receiver enters safeboot mode if this pin is low at start up. The SAFEBOOT_N pin is internally connected to TIMEPULSE pin through a 1 kΩ series resistor.

Pin no.	Name	I/O	Description
23	VCC	I	Supply voltage
24	GND	I	Ground

Table 8: NEO-M9V-20B pin assignment



For detailed information on the pin functions and characteristics see the Integration manual [1].

4 Electrical specifications

For detailed information on the device integration, see the Integration manual [1].

4.1 Absolute maximum ratings

CAUTION. Risk of device damage. Exceeding the absolute maximum ratings may affect the lifetime and reliability of the device or permanently damage it. Do not exceed the absolute maximum ratings.

This product is not protected against overvoltage or reversed voltages. Use appropriate protection to avoid device damage from voltage spikes exceeding the specified boundaries.

Parameter	Symbol	Condition	Min	Max	Units
Power supply voltage	VCC		-0.5	3.6	V
Voltage ramp on VCC ¹⁰			20	8000	μs/V
Backup battery voltage	V_BCKP		-0.5	3.6	V
Voltage ramp on V_BCKP ¹⁰			20		μs/V
Input pin voltage	Vin	VCC ≤ 3.1 V	-0.5	VCC + 0.5	V
		VCC > 3.1 V	-0.5	3.6	V
VCC_RF output current	ICC_RF			300	mA
Supply voltage USB	V_USB		-0.5	3.6	V
USB signals	USB_DM, USB_DP		-0.5	V_USB + 0.5 V	
Input power at RF_IN	Prfin	source impedance = 50 Ω, continuous wave		13 ¹¹	dBm
Storage temperature	Tstg		-40	+85	°C

Table 9: Absolute maximum ratings

4.2 Operating conditions

Extreme operating temperatures can significantly impact the specified values. If an application operates near the min or max temperature limits, ensure the specified values are not exceeded.

Parameter	Symbol	Min	Typical	Max	Units	Condition
Power supply voltage	VCC	2.7	3.0	3.6	V	
Supply voltage for USB interface	V_USB	3.0		3.6	V	
V_USB current	I_USB		2.0		mA	
Backup battery voltage	V_BCKP	1.65		3.6	V	
Backup battery current ^{12, 13}	I_BCKP		45		μA	V_BCKP = 3 V, VCC = 0 V
SW backup current ¹³	I_SWBCKP		0.5		mA	
Input pin voltage range	Vin	0		VCC	V	
Digital IO pin low level input voltage	Vil			0.4	V	
Digital IO pin high level input voltage	Vih	0.8 * VCC			V	

¹⁰ Exceeding the ramp speed may permanently damage the device

¹¹ +13 dBm for outband; 0 dBm for inband

¹² To measure the I_BCKP, the receiver should first be switched on, i.e. VCC and V_BCKP is available. Then set VCC to 0 V while the V_BCKP remains available. Afterward, measure the current consumption at the V_BCKP.

¹³ The value has been characterized at 25 °C ambient temperature.

Parameter	Symbol	Min	Typical	Max	Units	Condition
Digital IO pin low level output voltage	Vol			0.4	V	I _{ol} = 2 mA ¹⁴
Digital IO pin high level output voltage	Voh	VCC – 0.4			V	I _{oh} = 2 mA ¹⁴
Pull-up resistance for SCL, SDA	R _{pu}	7	15	30	kΩ	
Pull-up resistance for D_SEL, RXD, TXD, SAFEBOOT_N, EXTINT	R _{pu}	30	75	130	kΩ	
Pull-up resistance for RESET_N	R _{pu}	7	10	13	kΩ	
VCC_RF voltage	VCC_RF		VCC – 0.1		V	
VCC_RF output current	ICC_RF			50	mA	
Input impedance at RF_IN	Z _{in}		50		Ω	
Receiver chain noise figure ¹⁵	NF _{tot}		3.5		dB	
External gain (at RF_IN)	Ext_gain			30	dB	
Operating temperature	Topr	–40	+25	+85	°C	

Table 10: Operating conditions

4.3 Indicative power requirements

Table 11 provides examples of typical current requirements when using a cold start command. The given values are total system supply current for a possible application including RF and baseband sections.

All values in Table 11 have been measured at 25 °C ambient temperature. SBAS and QZSS were activated in all measurements.



The actual power requirements vary depending on the FW version used, external circuitry, number of satellites tracked, signal strength, type and time of start, duration, and conditions of test.

Symbol	Parameter	Conditions	GPS+GLO+GAL+BDS	GPS+GLO	BDS+GLO	Unit
I _{PEAK}	Peak current	Acquisition	67	63	64	mA
I _{VCC} ¹⁶	VCC current	Acquisition	53	43	47	mA
		Tracking	49	43	44	mA

Table 11: Currents to calculate the indicative power requirements

¹⁴ TIMEPULSE has 4 mA current drive/sink capability

¹⁵ Only valid for GPS

¹⁶ Simulated signal, current measured at 3.0 V

5 Communications interfaces

NEO-M9V-20B has several communications interfaces¹⁷, including UART, SPI, I2C and USB.

All the inputs have internal pull-up resistors in normal operation and can be left open if not used. All the PIOs are supplied by VCC, therefore all the voltage levels of the PIO pins are related to VCC supply voltage.

5.1 UART

NEO-M9V-20B has one UART interface which supports configurable baud rates. See the Integration manual [1].

Hardware flow control is not supported.

The UART1 is enabled if D_SEL pin of the module is left open or "high".

Symbol	Parameter	Min	Max	Unit
R_u	Baud rate	4800	921600	bit/s
Δ_{Tx}	Tx baud rate accuracy	-1%	+1%	-
Δ_{Rx}	Rx baud rate tolerance	-2.5%	+2.5%	-

Table 12: NEO-M9V-20B UART specifications

5.2 SPI

The SPI interface is disabled by default. The SPI interface shares pins with UART and I2C and can be selected by setting D_SEL = 0. The SPI interface can be operated in peripheral mode only. The maximum transfer rate using SPI is 125 kB/s and the maximum SPI clock frequency is 5.5 MHz.

The SPI timing parameters for peripheral operation are defined in Figure 3. Default SPI configuration is CPOL = 0 and CPHA = 0.

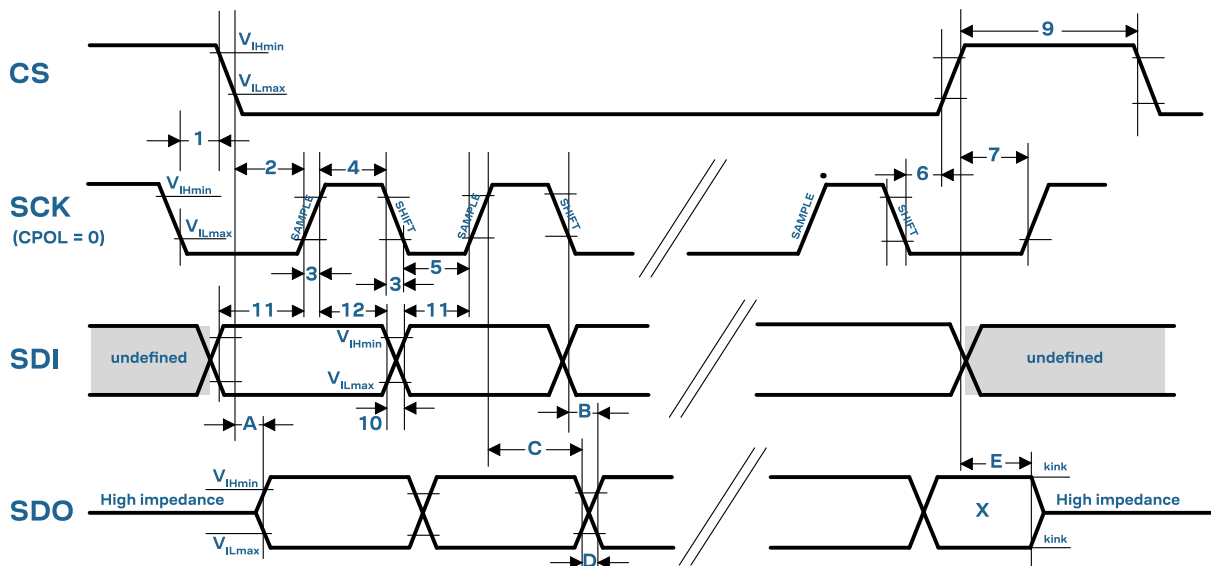

Figure 3: NEO-M9V-20B SPI specification mode 1: CPHA=0 SCK = 5.33 MHz

¹⁷ The signal names and related terms have been replaced with new terminology in this document.

Symbol	Parameter	Min	Max	Unit
1	CS deassertion hold time	23	-	ns
2	Chip select time (CS to SCK)	20	-	ns
3	SCK rise/fall time	-	7	ns
4	SCK high time	24	-	ns
5	SCK low time	24	-	ns
6	Chip deselect time (SCK falling to CS)	30	-	ns
7	Chip deselect time (CS to SCK)	30	-	ns
9	CS high time	32	-	ns
10	SDI transition time	-	7	ns
11	SDI setup time	16	-	ns
12	SDI hold time	24	-	ns

Table 13: SPI peripheral input timing parameters 1 - 12

Symbol	Parameter	Min	Max	Unit
A	SDO data valid time (CS)	12	40	ns
B	SDO data valid time (SCK), weak driver mode	15	40	ns
C	SDO data hold time	100	140	ns
D	SDO rise/fall time, weak driver mode	0	5	ns
E	SDO data disable lag time	15	35	ns

Table 14: SPI peripheral timing parameters A - E, 2 pF load capacitance

Symbol	Parameter	Min	Max	Unit
A	SDO data valid time (CS)	16	55	ns
B	SDO data valid time (SCK), weak driver mode	20	55	ns
C	SDO data hold time	100	150	ns
D	SDO rise/fall time, weak driver mode	3	20	ns
E	SDO data disable lag time	15	35	ns

Table 15: SPI peripheral timing parameters A - E, 20 pF load capacitance

Symbol	Parameter	Min	Max	Unit
A	SDO data valid time (CS)	26	85	ns
B	SDO data valid time (SCK), weak driver mode	30	85	ns
C	SDO data hold time	110	160	ns
D	SDO rise/fall time, weak driver mode	13	45	ns
E	SDO data disable lag time	15	35	ns

Table 16: SPI peripheral timing parameters A - E, 60 pF load capacitance

5.3 I2C

An I2C interface is available for communication with an external host CPU in I2C Fast-mode. Backwards compatibility with Standard-mode I2C bus operation is not supported. The interface can be operated only in peripheral mode with a maximum bit rate of 400 kbit/s. The interface can make use of clock stretching by holding the SCL line LOW to pause a transaction. In this case, the bit transfer rate is reduced. The maximum clock stretching time is 20 ms.

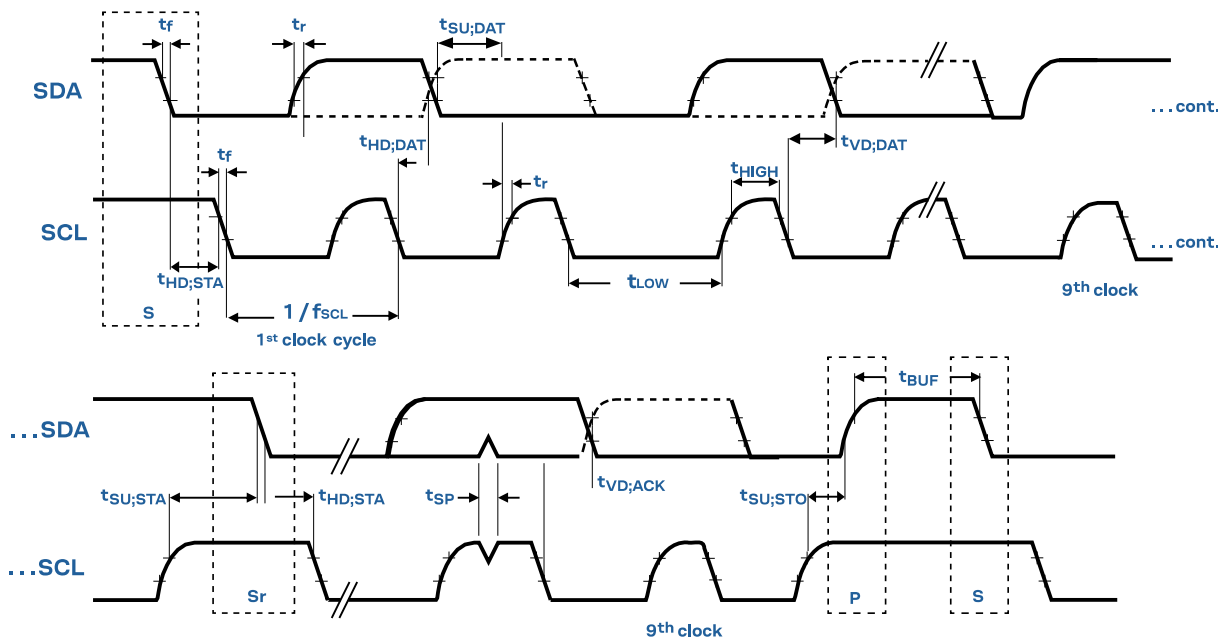

$$V_{IL} = 0.3 V_{DD}$$

$$V_{IH} = 0.7 V_{DD}$$

Figure 4: NEO-M9V-20B I2C peripheral specification

Symbol	Parameter	I2C Fast-mode		Unit
		Min	Max	
f_{SCL}	SCL clock frequency	0	400	kHz
$t_{HD;STA}$	Hold time (repeated) START condition	0.6	-	μ s
t_{LOW}	Low period of the SCL clock	1.3	-	μ s
t_{HIGH}	High period of the SCL clock	0.6	-	μ s
$t_{SU;STA}$	Setup time for a repeated START condition	0.6	-	μ s
$t_{HD;DAT}$	Data hold time	0 ¹⁸	- ¹⁹	μ s
$t_{SU;DAT}$	Data setup time	100 ²⁰	-	ns
t_r	Rise time of both SDA and SCL signals	-	300 (for C = 400pF)	ns
t_f	Fall time of both SDA and SCL signals	-	300 (for C = 400pF)	ns
$t_{SU;STO}$	Setup time for STOP condition	0.6	-	μ s
t_{BUF}	Bus-free time between a STOP and START condition	1.3	-	μ s
$t_{VD;DAT}$	Data valid time	-	0.9 ¹⁹	μ s
$t_{VD;ACK}$	Data valid acknowledge time	-	0.9 ¹⁹	μ s
V_{nL}	Noise margin at the low level	0.1 VCC	-	V

¹⁸ External device must provide a hold time of at least one transition time (max 300 ns) for the SDA signal (with respect to the min V_{ih} of the SCL signal) to bridge the undefined region of the falling edge of SCL.

¹⁹ The maximum $t_{HD;DAT}$ must be less than the maximum $t_{VD;DAT}$ or $t_{VD;ACK}$ with a maximum of 0.9 μ s by a transition time. This maximum must only be met if the device does not stretch the LOW period (t_{LOW}) of the SCL signal. If the clock stretches the SCL, the data must be valid by the set-up time before it releases the clock.

²⁰ When the I2C peripheral is stretching the clock, the $t_{SU;DAT}$ of the first bit of the next byte is 62.5 ns.

Symbol	Parameter	I2C Fast-mode		Unit
		Min	Max	
V _{nH}	Noise margin at the high level	0.2 VCC	-	V

Table 17: NEO-M9V-20B I2C peripheral timings and specifications

The I2C interface is only available with the UART default mode. If the SPI interface is selected by using D_SEL = 0, the I2C interface is not available.

5.4 USB

The USB 2.0 FS (full speed, 12 Mbit/s) interface can be used for host communication. Due to the hardware implementation, it may not be possible to certify the USB interface. The V_USB pin supplies the USB interface.

5.5 WT (wheel tick) and DIR (forward/reverse indication)

NEO-M9V-20B pin 4 (WT) is available as a wheel-tick input. The pin 15 (DIR) is available as a direction input (forward/reverse indication).

By default the wheel tick count is derived from the rising edges of the WT input.

For optimal performance the wheel tick resolution should be less than 5 cm. With the maximum supported wheel tick resolution is 40 cm.

The DIR input shall indicate whether the vehicle is moving forwards or backwards.

Alternatively, the vehicle WT (or speed) and DIR inputs can be provided via one of the communication interfaces with UBX-ESF-MEAS messages.

For more details, see the Integration manual [1].

5.6 Default interface settings

Interface	Settings
UART	38400 baud, 8 bits, no parity bit, 1 stop bit. Output messages: NMEA GGA, GLL, GSA, GSV, RMC, VTG, TXT (no UBX). Input protocols: UBX and NMEA.
USB	Output messages activated as in UART. Input protocols available as in UART.
I2C	Output messages activated as in UART. Input protocols available as in UART.
SPI	Output messages activated as in UART. Input protocols available as in UART.

Table 18: Default interface settings

Refer to the applicable Interface description [2] for information about further settings.

By default NEO-M9V-20B outputs NMEA messages that include satellite data for all GNSS bands being received. This results in a higher-than-before NMEA load output for each navigation period. Make sure the UART baud rate being used is sufficient for the selected navigation rate and the number of GNSS signals being received.

6 Mechanical specifications

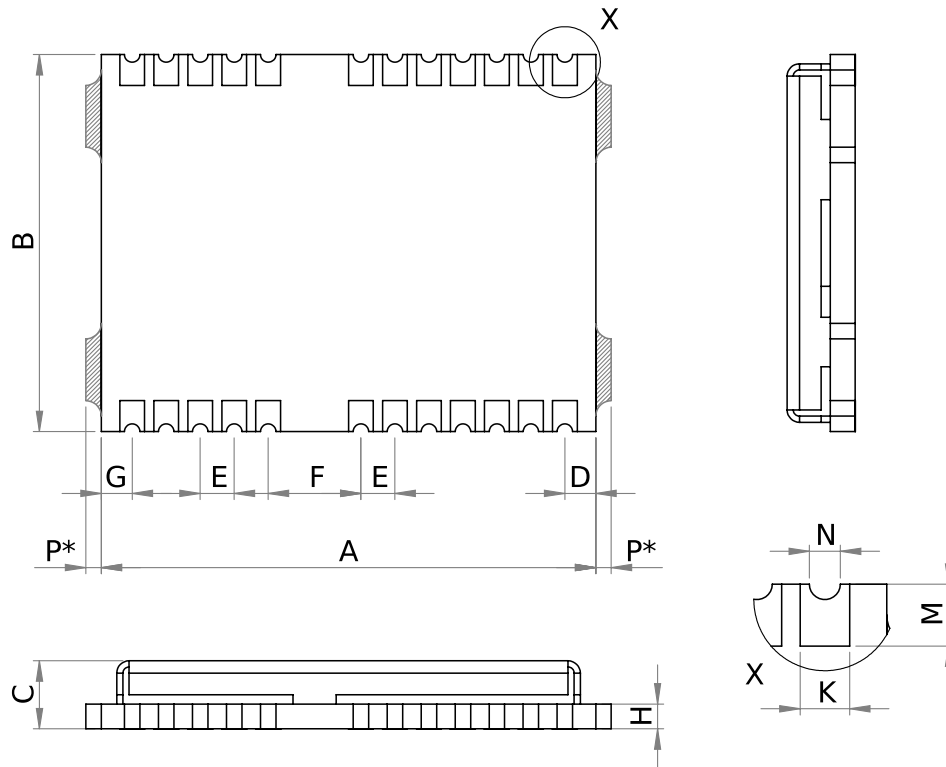

Figure 5: NEO-M9V-20B mechanical drawing

Symbol	Min (mm)	Typical (mm)	Max (mm)	
A	15.9	16.0	16.1	
B	12.1	12.2	12.3	
C	2.2	2.4	2.6	
D	0.9	1.0	1.1	
E	1.0	1.1	1.2	
F	2.9	3.0	3.1	
G	0.9	1.0	1.1	
H	-	0.82	-	
K	0.7	0.8	0.9	
M	0.8	0.9	1.0	
N	0.4	0.5	0.6	
P*	0.0	-	0.5	The de-paneling residual tabs may be on either side (not both).
Weight		1.6 g		

Table 19: NEO-M9V-20B mechanical dimensions



The mechanical picture of the de-paneling residual tabs (P*) is an approximate representation. The shape and position may vary.



Take the size of the de-paneling residual tabs into account when designing the component keep-out area.

7 Qualifications and approvals

Quality and reliability	
Product qualification	Qualified according to u-blox qualification policy, based on a subset of AEC-Q104
Chip qualification	Modules are based on AEC-Q100 qualified GNSS chips
Manufacturing	Manufactured at ISO/TS 16949 certified sites
Environmental	
RoHS compliance	Yes
Moisture sensitivity level (MSL) ^{21, 22}	4
Type approvals	
European RED certification (CE)	Declaration of Conformity (DoC) is available on the u-blox website .
UK conformity assessment (UKCA)	Yes

Table 20: Qualifications and approvals

²¹ For the MSL standard, see IPC/JEDEC J-STD-020 and J-STD-033, available on www.jedec.org

²² For more information regarding moisture sensitivity levels, labelling, storage and drying, see the Product packaging reference guide [3]

8 Product handling

8.1 Packaging

8.1.1 Reels

The NEO-M9V-20B receivers are deliverable in quantities of 500 pieces on a reel. The receivers are shipped on reel type A, as specified in the Product packaging reference guide [3].

8.1.2 Tapes

Figure 6 shows the feed direction, orientation and dimensions of the NEO-M9V-20B modules on the tape (measurements in mm).

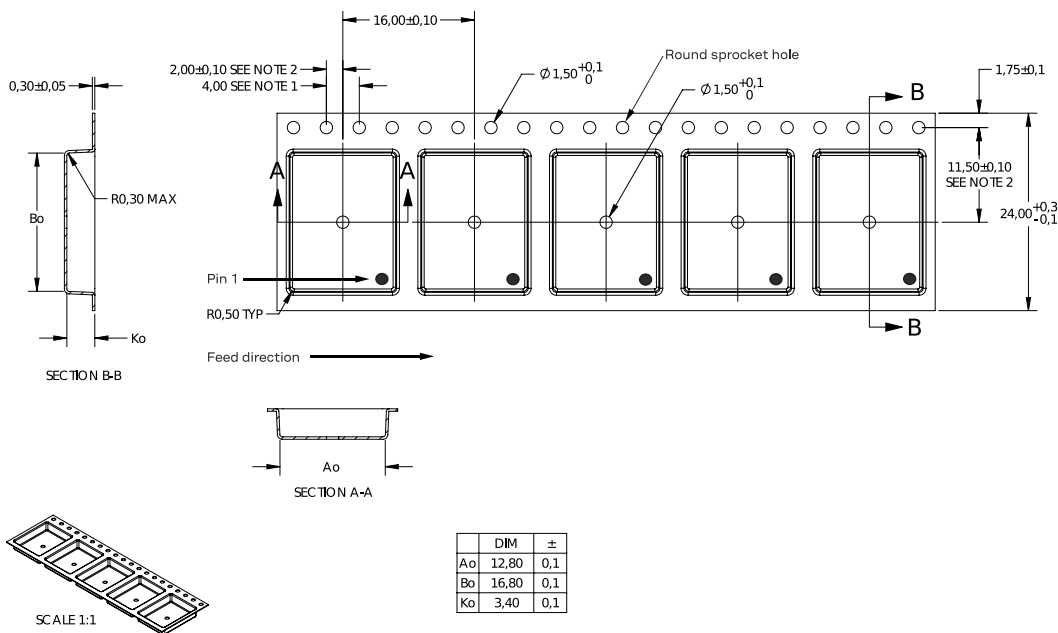

- NOTES:
1. 10 SPROCKETHOLE PITCH CUMULATIVE TOLERANCE ± 0.2
 2. POCKET POSITION RELATIVE TO SPROCKETHOLE MEASURED AS TRUE POSITION OF POCKET, NOT POCKETHOLE.
 3. Ao AND Bo ARE MEASURED ON A PLANE AT A DISTANCE "R" ABOVE THE BOTTOM OF THE POCKET.

Figure 6: Feed direction, orientation, and dimensions (in mm) of NEO-M9V-20B modules on the tape

9 Product marking and ordering information

This section provides information about product marking and ordering.

9.1 Product marking

The product marking provides information on NEO-M9V-20B and its revision, as in [Figure 7](#). For a description of the product marking, see [Table 21](#).

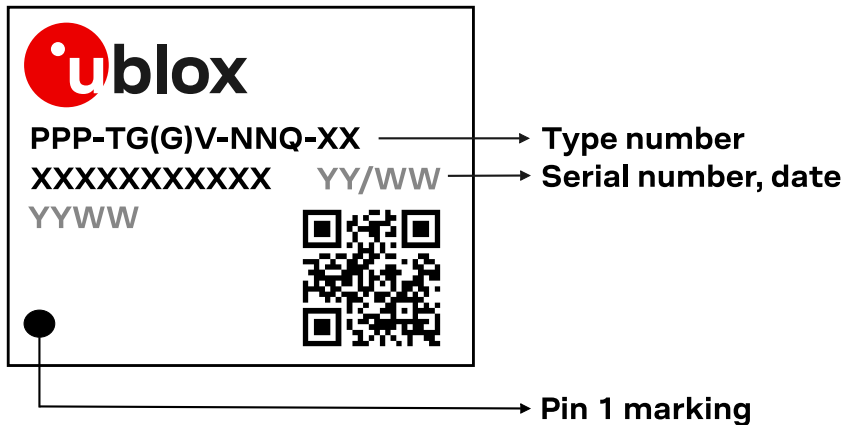

Figure 7: Example of NEO-M9V-20B product marking

Code	Meaning	Example
PPP	Form factor	NEO
TG(G)	Platform	M9 = u-blox M9
V	Variant	V = MDR Multi-mode Dead Reckoning
NN	Major product version	00, 01, ..., 99
Q	Product grade	A = Automotive, B = Professional, C= Standard
XX	Revision	Hardware and firmware revisions
YY/WW or YYWW	Production date	Year/week, e.g. 24/04 or 2404
XXXXXXXXXXXX	Serial number	Alphanumeric characters, e.g. BN600001181
Other information	QR code	For internal/technical use.

Table 21: Description of product marking

9.2 Product identifiers

The NEO-M9V-20B label features three product identifiers: product name, ordering code, and type number. The product name identifies all u-blox products. It is used in documentation such as this Data sheet and is independent of packaging and product grade. The ordering code indicates the major product version and product grade, and the type number additionally specifies the hardware and firmware revisions.

[Table 22](#) describes the three different product identifiers used in the NEO-M9V-20B label

Identifier	Format	Example
Product name	PPP-TG(G)V	NEO-M9V
Ordering code	PPP-TG(G)V-NNQ	NEO-M9V-20B
Type number	PPP-TG(G)V-NNQ-XX	NEO-M9V-20B-00

Table 22: Product identifiers

9.3 Ordering codes

Ordering code	Product	Remark
NEO-M9V-20B	u-blox NEO-M9V module, Professional grade	

Table 23: Product ordering codes

u-blox provides information on product changes affecting the form factor, size or function of the product. For the Product change notifications (PCNs), see our website at <https://www.u-blox.com/en/product-resources>.

Related documents

- [1] NEO-M9V Integration manual, [UBX-21029776](#)
- [2] MDR 2.16 Interface description, [UBX-22037308](#)
- [3] Product packaging reference guide, [UBX-14001652](#)



For regular updates to u-blox documentation and to receive product change notifications please register on our homepage <https://www.u-blox.com>.

Revision history

Revision	Date	Status / comments
R01	05-Jan-2022	Advance information
R02	25-Mar-2022	Initial production for NEO-M9V-20B-00
R03	30-May-2022	Mass production for NEO-M9V-20B-00
R04	16-Mar-2023	Mass production for NEO-M9V-20B-01 with MDR 2.16 FW Updated I2C and SPI timing specifications in section Communications interfaces Updated VCC_RF output current in table Absolute maximum ratings Added timepulse details in table Operating conditions Updated backup current in table Operating conditions Updated section Mechanical specification
R05	18-Apr-2023	Updated Receiver chain noise figure in table Operating conditions
R06	07-Aug-2024	Updated the descBlockDiagram
R07	02-Jun-2025	Updated the reel type, delivery quantity and tape dimensions in sections Reels and Tapes Updated AssistNow service information

Contact

u-blox AG

Address: Zürcherstrasse 68
8800 Thalwil
Switzerland

For further support and contact information, visit us at www.u-blox.com/support.