

## Data Sheet | Item Number: 216-108

Ferrule; Sleeve for 6 mm<sup>2</sup> / AWG 10; uninsulated; electro-tin plated; silver-colored

<https://www.wago.com/216-108>



Color: ■ silver-colored

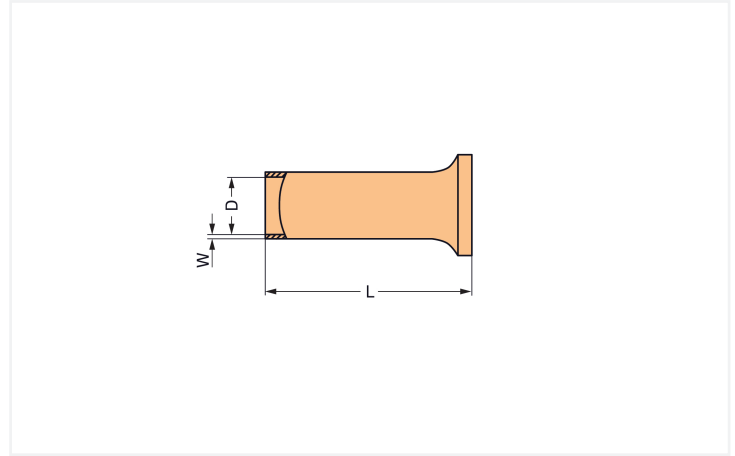

Dimensions in mm

### Connection Data

Metric cross-section of the ferrule	6 mm <sup>2</sup>
Strip length	12 mm / 0.47 inches
Cross-section (AWG) of ferrule	10 AWG

### Physical data

Total length	12 mm
Wall thickness of crimp sleeve	0.2 mm
Diameter crimp sleeve inside	3.5 mm

### Mechanical data

Plastic collar	No
----------------	----

### Material data

Color	silver-colored
Fire load	0 MJ
Weight	0.2 g

### Commercial data

Product Group	2 (Terminal Block Accessories)
PU (SPU)	1000 (250) pcs
Packaging type	Box
Country of origin	DE
GTIN	4017332277709
Customs tariff number	85369010000

### Product Classification

UNSPSC	39121405
eCl@ss 10.0	27-40-02-01
eCl@ss 9.0	27-40-02-01
ETIM 9.0	EC000005
ETIM 10.0	EC000005
ECCN	NO US CLASSIFICATION

### Environmental Product Compliance

RoHS Compliance Status	Compliant, No Exemption
------------------------	-------------------------

### Downloads

#### Environmental Product Compliance

<b>Compliance Search</b>	
Environmental Product Compliance 216-108	<a href="#">↓</a>

### Documentation

<b>Bid Text</b>			
216-108	11.09.2017	doc 24.00 KB	<a href="#">↓</a>
216-108	19.02.2019	xml 2.77 KB	<a href="#">↓</a>

### Installation Notes

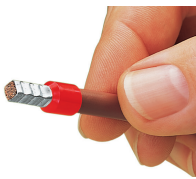

A perfect gas-tight crimp – both electrically and mechanically reliable

Subject to changes. Please also observe the further product documentation!

Current addresses can be found at: [www.wago.com](https://www.wago.com)