



NVIDIA Jetson Orin NX Series Modules

Ampere GPU + Arm Cortex-A78AE CPU + LPDDR5

Data Sheet

Revision History

DS-10712-001_v1.7

Version	Date	Description
v0.1	October 18, 2021	Initial preliminary release
v0.4	April 15, 2022	Updated: <ul style="list-style-type: none"> • PCIe Pin Descriptions • MODULE_ID and SHUTDOWN_REQ* in Control Pin Descriptions • Jetson Orin NX Pin List • Recommended Operating Conditions
v0.5	November 8, 2022	Updated: <ul style="list-style-type: none"> • Temperature Range for clarity • CSI section for clarity • ISP section for clarity • Display Controller section for clarity Added: <ul style="list-style-type: none"> • Sensor Processing Engine section • Security Engine section • Module Drawing and Dimensions
v0.6	January 13, 2023	Updated: <ul style="list-style-type: none"> • Module Drawing and Dimensions Added: <ul style="list-style-type: none"> • Absolute Maximum Ratings table • Reliability Report table
v1.0	February 22, 2023	Updated: <ul style="list-style-type: none"> • Product Design Guide and Thermal Design Guide document names. • USB 3.2 Operation text for clarification. • Description for SYS_RESET* to 10kΩ pull-up to VDD_1V8 on the module. • Description for CLK_32K_OUT to 2.2kΩ pull-up to VDD_1V8 on the module. • PMIC_BBAT Pin Description table for clarity. Added: <ul style="list-style-type: none"> • Storage and Handling information table.
v1.1	December 8, 2023	Updated: <ul style="list-style-type: none"> • UART block frequency from 200MHz to 68MHz and baud rate from 12.5Mbps to 4.25Mbps • VI 5.0 to VI 6.0 • ISP 5.0 to ISP 6.0 • CUDA 10.2 to CUDA 11.4+ • RTC accuracy under PMIC_BBAT • Open Drain Pin Type DC Characteristics table

Version	Date	Description
		<ul style="list-style-type: none"> • PCIe GEN3 to GEN4 • Pin direction in Camera Pin Descriptions table <p>Added:</p> <ul style="list-style-type: none"> • Operating Lifetime (24x7): 5 years <p>Removed features not supported:</p> <ul style="list-style-type: none"> • Color Decompression references • DMIC references • DSPK references • HDMI 2.1 (FRL) reference
v1.2	October 22,2024	<p>Updated:</p> <ul style="list-style-type: none"> • Serial Peripheral Interface (SPI): initiator/target timing diagrams and parameter tables
v1.3	November 18, 2024	<p>Modified:</p> <ul style="list-style-type: none"> • Pin #217 (MODULE_ID) description.
v1.4	December 20, 2024	<p>Added:</p> <ul style="list-style-type: none"> • Extended support to include MAXN_SUPER operation • CUDA Core Performance
v1.5	December 31, 2024	<p>Updated VDD_IN description to reflect 8V minimum to support MAXN_SUPER at 40W.</p>
v1.6	May 22, 2025	<p>Added note at beginning of Overview section to increase visibility of the need to review software release documentation for information on supported capabilities.</p> <p>Added note to clarify HDCP support: HDCP is disabled by default. Contact NVIDIA for activation.</p>
v1.7	February 20,2026	<p>Updated incorrect storage temperature reference.</p> <p>Added MTBF for MAXN_SUPER mode.</p>

Table of Contents

Chapter 1.	Overview.....	1
Chapter 2.	Functional Description	4
2.1	Ampere GPU.....	4
2.1.1	Compute Features	5
2.1.2	Graphic Features.....	6
2.2	PVA and DLA Cluster	6
2.3	Cortex CPU Complex	7
2.4	Memory Subsystem.....	8
2.5	Memory.....	9
2.6	Video Input Interfaces	10
2.6.1	MIPI Camera Serial Interface (CSI)	10
2.6.2	Video Input (VI)	12
2.6.3	Image Signal Processor (ISP)	12
2.7	Sensor Processing Engine.....	12
2.8	Security Subsystem.....	13
2.8.1	Platform Security Controller	13
2.8.2	Security Engine.....	13
2.9	Display Controller	14
2.10	High-Definition Audio-Video Subsystem.....	15
2.10.1	Multi-Standard Video Decoder.....	15
2.10.2	Multi-Standard Video Encoder	16
2.10.3	JPEG Processing Block.....	17
2.10.4	Video Image Compositor (VIC).....	17
2.10.5	Audio Processing Engine (APE)	18
2.10.6	High-Definition Audio (HDA)	19
2.11	Interface Descriptions.....	19
2.11.1	Universal Serial Bus (USB)	19
2.11.2	PCI Express (PCIe)	21
2.11.3	Serial Peripheral Interface (SPI).....	23
2.11.4	Universal Asynchronous Receiver/Transmitter (UART)	25
2.11.5	Controller Area Network (CAN)	26
2.11.6	Inter-Chip Communication (I2C)	28
2.11.7	Inter-IC Sound (I2S).....	29
2.11.8	Gigabit Ethernet.....	30
2.11.9	Fan.....	30
2.11.10	Pulse Width Modulator (PWM).....	30
2.12	Deep Learning Accelerator (DLA)	31
2.13	Programmable Vision Accelerator (PVA).....	32

Chapter 3.	Power and System Management.....	33
3.1	Power Rails.....	34
3.2	Power Domains/Islands.....	34
3.3	Power Management Controller (PMC).....	34
3.4	Resets.....	34
3.5	PMIC_BBAT.....	35
3.6	Power Sequencing.....	35
3.6.1	Power Up.....	35
3.6.2	Power Down.....	35
3.7	Power States.....	36
3.7.1	ON State.....	36
3.7.2	OFF State.....	36
3.7.3	SLEEP State.....	37
3.8	Thermal and Power Monitoring.....	37
Chapter 4.	Pin Definitions.....	38
4.1	Power-on Reset Behavior.....	38
4.2	Sleep Behavior.....	39
4.3	GPIO.....	39
4.4	Pin List.....	40
Chapter 5.	Electrical, Mechanical, and Thermal Characteristics.....	44
5.1	Operating and Absolute Maximum Ratings.....	44
5.2	Digital Logic.....	45
5.3	Environmental and Mechanical Screening.....	46
5.4	Storage and Handling.....	47
5.5	Module Drawing and Dimensions.....	48

List of Figures

Figure 2-1: SPI Initiator Timing.....	24
Figure 2-2: SPI Target Timing.....	25
Figure 3-1: Power State Transition Diagram.....	36
Figure 5-1: Top View.....	48
Figure 5-2: Bottom View.....	49

List of Tables

Table 2-1: GPU Operation.....	5
Table 2-2: PVA Operation.....	7
Table 2-3: DLA Operation.....	7
Table 2-4: CPU Operation.....	8
Table 2-5: CSI Pin Descriptions.....	11
Table 2-6: Camera Pin Descriptions.....	11
Table 2-7: Supported Video Decode Streams.....	16
Table 2-8: Supported Video Encode Streams.....	16
Table 2-9: NVJPEG Streams per Instance.....	17
Table 2-10: USB 2.0 Pin Descriptions.....	20
Table 2-11: USB 3.2 Pin Descriptions.....	20
Table 2-12: PCIe Pin Descriptions.....	21
Table 2-13: SPI Mode Descriptions.....	23
Table 2-14: SPI Pin Descriptions.....	23
Table 2-15: SPI Initiator Timing Parameters.....	24
Table 2-16: SPI Target Timing Parameters.....	25
Table 2-17: UART Pin Descriptions.....	26
Table 2-18: CAN Pin Descriptions.....	28
Table 2-19: I2C Pin Descriptions.....	28
Table 2-20: I2S Pin Descriptions.....	29
Table 2-21: Gigabit Ethernet Pin Descriptions.....	30
Table 2-22: PWM Pin Descriptions.....	31
Table 3-1: Power and System Control Pin Descriptions.....	33
Table 3-2: PMIC_BBAT Pin Descriptions.....	35
Table 3-3: OFF State Events.....	36
Table 3-4: SLEEP and WAKE Events.....	37
Table 4-1: GPIO Pin Descriptions.....	39
Table 5-1: Recommended Operating Conditions.....	44
Table 5-2: Absolute Maximum Ratings.....	44
Table 5-3: CMOS Pin Type DC Characteristics.....	45
Table 5-4: Open Drain Pin Type DC Characteristics.....	45
Table 5-5: Environmental Testing.....	46
Table 5-6: Typical Handling and Storage Environment.....	47

Chapter 1. Overview

Module	Description
Jetson Orin NX 16GB	Ampere GPU + Arm Cortex-A78AE CPU + 16GB LPDDR5
Jetson Orin NX 8GB	Ampere GPU + Arm Cortex-A78AE CPU + 8GB LPDDR5

Note: References to ONX and Jetson Orin NX can be read as Jetson Orin NX 16GB and Jetson Orin NX 8GB except where explicitly noted.



Important: This document provides detailed information on the capabilities of the hardware module, which may differ from supported configurations by provided software.

Refer to the Software Features Overview in the current release of the NVIDIA Jetson Linux Developer Guide for information on supported capabilities.

Description		Operation/Performance	
AI Performance			MAXN_SUPER
Jetson Orin NX (ONX) 16GB Number of Operations (up to)	Sparse	100 INT8 TOPs	157 INT8 TOPs
	Dense	50 INT8 TOPs	78 INT8 TOPs
Jetson Orin NX (ONX) 8GB Number of Operations (up to)	Sparse	70 INT8 TOPs	117 INT8 TOPs
	Dense	35 INT8 TOPs	58 INT8 TOPs
Ampere GPU			MAXN_SUPER
End-to-end lossless compression Tile Caching OpenGL® 4.6 OpenGL ES 3.2 Vulkan™ 1.1 ^o CUDA 11.4 ⁺			
Jetson Orin NX (ONX) 16GB		1024 NVIDIA® CUDA® cores 32 Tensor cores:	
Maximum Operating Frequency (up to):		918 MHz	1,173 MHz
CUDA Core Performance: Number of Operations (up to)		1.88 FP32 TFLOPs 3.76 FP16 TFLOPs	2.40 FP32 TFLOPs 4.80 FP16 TFLOPs
Jetson Orin NX (ONX) 8GB		1024 NVIDIA® CUDA® cores 32 Tensor cores:	
Maximum Operating Frequency (up to):		765 MHz	1,173 MHz
CUDA Core Performance: Number of Operations (up to)		1.56 FP32 TFLOPs 3.12 FP16 TFLOPs	2.40 FP32 TFLOPs 4.80 FP16 TFLOPs

Description	Operation/Performance	
Deep Learning Accelerator (DLA)		MAXN_SUPER
Jetson Orin NX (ONX) 16GB: 2x NVDLA		
Maximum Operating Frequency (up to)	614 MHz	1229 MHz
Sparse INT8 Operations (up to)	40 TOPS	80 TOPS
Jetson Orin NX (ONX) 8GB: 1x NVDLA		
Maximum Operating Frequency (up to)	610 MHz	1229 MHz
Sparse INT8 Operations (up to)	20 TOPS	40 TOPS
CPU Complex		
ONX 16GB: 8x cores ONX 8GB: 6x cores Arm® Cortex® A78AE v8.2 (64-bit) heterogeneous multi-processing (HMP) CPU architecture 2x Clusters: (4x 256KB L2 +2MB L3) + 4MB LLC L3 Cache: 4 MB (shared across all clusters) Spec_int rate: 167 with 8x cores, 130 with 6x cores		
Operating Frequency per Core (up to):	2 GHz	
Memory Subsystem		
ONX 16GB (2x 8GB) memory with 128bit LPDDR5 DRAM ONX 8GB (2x 4GB) memory with 128bit LPDDR5 DRAM 128-bit AES Encryption System MMU TrustZone (TZ) Secure and OS-protection regions		
Maximum Operating Frequency (up to)	3200 MHz	
Peak Memory Bandwidth	102 GB/s	
HD Video		
Decode		
Supported Standards: H.265 (HEVC), H.264, VP9, AV1 (see Multi-Standard Video Decoder section for detailed description)		
Encode		
Supported Standards: H.265 (HEVC), H.264, AV1 (see Multi-Standard Video Encoder section for detailed description)		
Display Controller Subsystem		
1x shared HDMI 2.1, eDP 1.4 VESA DisplayPort 1.4a HBR3		
Maximum Resolution eDP/DP/HDMI (up to)	7680x4320 at 30 Hz	
PCLK (up to)	1080 MHz	
Always On Sensor Processor Engine		
The Always On (AO) Sensor Processor Engine (SPE) is a Cortex-R5 subsystem with integrated instruction cache (I-cache), data cache (D-cache) and a tightly coupled memory (TCM) interface		
Audio Subsystem		
Dedicated programmable audio processor Arm Cortex A9 with NEON PDM in/out Industry-standard High-Definition Audio (HDA) controller provides a multi-channel audio path to the HDMI® interface		
Networking		
10/100/1000 Gigabit Ethernet Media Access Controller (MAC)		
Imaging		
Eight lanes MIPI CSI-2 D-PHY 2.1 (20 Gbps)		

Description	Operation/Performance
Security	
<p>Dedicated Platform Security Controller (PSC) for critical security use-cases, including secure boot and key management. Two dedicated NIST-compliant Security Engines (SE) for hashing, symmetric/public key cryptographic algorithms, key derivation, and random number generation.</p> <ul style="list-style-type: none"> TrustZone technology support for DRAM and peripherals Side channel countermeasures (AES/RSA/ECC) Hardware acceleration for various cryptographic operations and hardware assisted Key protection Hardware random number generator Provides countermeasures against physical attacks (e.g., clock, voltage and temperature monitors) 	
Storage	
<p>Supports External Storage</p> <ul style="list-style-type: none"> > NVMe through PCIe <ul style="list-style-type: none"> PCIe0, x4 (Orin UPHY0 Lanes [7:4]), Ctrl #4 PCIe2, x2 (Orin UPHY2 Lanes [1:0]), Ctrl #7 PCIe2, x1 (Orin UPHY2 Lane [0]), Ctrl #7 PCIe3, x1 (Orin UPHY2 Lane [1]), Ctrl #9 > SSD through USB 3.2: <ul style="list-style-type: none"> USB 3.2 Port 0, 1, or 2 	
Peripheral Interfaces	
<p>USB: xHCI host controller with integrated PHY (up to) 3x USB 3.2, 3x USB 2.0</p>	
<p>PCIe: Up to GEN4 3 x1 (or 1 x2 + 1 x1) + 1 x4 x1 and x2 (supports Root Port only), x4 (supports Root Port or Endpoint modes)</p>	
<p>Audio: 2x I2S/2x Audio Hub (AHUB) Supports I2S, RJM, LJM, PCM, TDM (multi-slot mode)</p>	
<p>UART: 3 x UART</p>	
<p>CAN: Single independent CAN port/channel supports connectivity to one CAN network</p>	
<p>SPI: 2 x SPI</p>	
<p>I2C: 4 x I2C</p>	
<p>PWM: 4 x PWM outputs</p>	
<p>GPIO: 15 x GPIOs</p>	
Mechanical	
<p>Module Size: 69.6 mm x 45 mm 260 pin SO-DIMM Connector</p>	
Operating Requirements	
<p>Temp. Range (T_J): -25°C – 105°C Supported Power Input: 5V-20V (8V-20V for MAXN_SUPER) Maximum Orin SoC Operating Temperature = Slowdown Temp = 99°C Operating Lifetime (24x7): 5 years Jetson Orin NX 16GB Modes: 10W 15W 25W 40W (MAXN_SUPER) Jetson Orin NX 8GB Modes: 10W 15W 20W 40W (MAXN_SUPER)</p>	
Notes:	
<ul style="list-style-type: none"> Refer to the Software Features section of the latest L4T Development Guide for a list of supported features; all features may not be available. ◇ Product is based on a published Khronos Specification and is expected to pass the Khronos Conformance Process. Current conformance status can be found at www.khronos.org/conformance. * See the <i>Jetson Orin NX Series Thermal Design Guide</i> for details 	

Chapter 2. Functional Description

NVIDIA® Jetson Orin™ NX brings AI supercomputer performance to the edge in a compact system-on-module (SOM) which is smaller than a credit card. Jetson Orin NX is built around a low-power version of the NVIDIA Orin SoC, combining the NVIDIA Ampere™ GPU architecture with 64-bit operating capability, integrated advanced multi-function video and image processing, and NVIDIA Deep Learning Accelerators.

Compute performance up to 100 (Sparse) INT8 TOPs and 50 (Dense) INT8 TOPs on the Jetson Orin NX 16GB and up to 70 (S) INT8 TOPs and 35 (D) INT8 TOPs on the Jetson Orin NX 8 GB enables the Jetson Orin NX to run multiple neural networks in parallel and process data from multiple high-resolution sensors simultaneously. It also offers a unique combination of performance and power advantages with a rich set of I/Os, from high-speed CSI and PCIe to low-speed I2Cs and GPIOs, allowing embedded and edge computing devices that demand increased performance but are constrained by size, weight, and power budgets.



Note: If MAXN_SUPER is enabled, the compute performance increases up to 157 (Sparse) INT8 TOPs and 78 (Dense) INT8 TOPs on Jetson Orin NX 16GB, and up to 117 (S) and 58 (D) on Jetson Orin NX 8GB

2.1 Ampere GPU

The NVIDIA Ampere GPU introduces a new design for the Streaming Multiprocessor (SM) that dramatically improves performance per watt and performance per area, along with supporting Tensor Cores and TensorRT Cores. Ampere GPUs improve on the previous NVIDIA Turing™ generation; and are software compatible so that the same APIs are used.

The NVIDIA Ampere Architecture GPU has several enhancements for compute and graphics capability that include:

- > Sparsity: fine grained structured sparsity doubles throughput and reduces memory usage.
- > 2x CUDA floating-point performance: higher compute math speed.
- > SM architecture improves bandwidth to the L1 cache and shared memory and reduces L1 miss latency.
- > Improved async compute and post-L2 cache compression compared to NVIDIA Turing.

The GPC is a dedicated hardware block for rasterization, shading, texturing, and compute. The GPU's core graphics functions are performed inside the GPC where the SM CUDA cores perform pixel/vertex/geometry shading and physics/compute calculations. Texture units perform texture filtering and load/store units fetch and save data to memory. Special Function Units (SFUs)

handle transcendental and graphics interpolation instructions. Tensor cores perform matrix multiplies to greatly accelerate DL inferencing. The RTcore unit assists Ray Tracing by accelerating Bounding Volume Hierarchy (BVH) traversal and intersection of scene geometry during Ray Tracing.

There are multiple texture processing clusters (TPC) units within a graphics processing cluster (GPC). Each TPC includes two SMs, a Polymorph Engine, two Texture Units, and a Ray Tracing core (RTcore). Each GPC includes a Raster Engine (ROP), which can access all of memory. Each SM is partitioned into four separate processing blocks, each with its own instruction buffer, scheduler, and 128 CUDA cores.

Finally, the PolyMorph engine handles vertex fetch, tessellation, viewport transform, attribute setup, and stream output. The SM geometry and pixel processing performance make it highly suitable for rendering advanced user interfaces and complex gaming applications. The power efficiency of the Ampere GPU enables this performance on devices with power-limited environments.

2.1.1 Compute Features

Ampere introduces third-generation NVIDIA Tensor Cores which offer a wider range of precisions including TensorFloat-32 (TF32), bfloat16, FP16, and INT8, all of which provide unmatched versatility and performance.

TensorFloat-32 (TF32) is a new format that uses the same 10-bit Mantissa as half-precision (FP16) math and is shown to have more than sufficient margin for the precision requirements of AI workloads. In addition, since the TF32 adopts the same 8-bit exponent as FP32 it can support the same numeric range.

Ampere adds support for structured sparsity. Not all the parameters of modern AI networks are needed for accurate predictions and inference, some can be converted to zeros to make the models “sparse” without compromising accuracy. The Tensor Cores in Ampere can provide up to 2x higher performance for inference of sparse models.

Ampere supports Compute Data Compression which can accelerate unstructured sparsity and other compressible data patterns. Compression in L2 provides up to a 4x improvement in DRAM read/write bandwidth, up to 4x improvement in L2 read bandwidth, and up to a 2x improvement in L2 capacity.

Ampere also supports many other enhancements for higher compute throughput.

Table 2-1: GPU Operation

Module	CUDA Cores	Tensor Cores	Operating Frequency per Core (up to)
Jetson Orin NX 16GB	1024	32	918 MHz 1173 MHz (MAXN_SUPER)
Jetson Orin NX 8GB	1024	32	765 MHz 1173 MHz (MAXN_SUPER)

2.1.2 Graphic Features

Ampere graphics capabilities include:

- > End-to-end lossless compression, including Post-L2 compression, enabling compression of M stores.
- > Tiled Caching
- > OpenGL 4.6+, Vulkan 1.2+, CUDA 11.4+
- > Adaptive Scalable Texture Compression (ASTC) LDR profile supported
- > Modern Graphics features:
 - Ray Tracing
 - DL Inferencing
 - Mesh Shaders
 - Sampler Feedback
 - Variable Rate Shading
 - Texture LOD in compute programs
- > Iterated blend, ROP OpenGL-ES blend modes
- > 2D BLIT from 3D class avoids channel switch
- > 2D color compression
- > Constant color render SM bypass
- > 2x, 4x, 8x MSAA with color and Z compression
- > Non-power-of-2 and 3D textures, FP16 texture filtering
- > FP16 shader support
- > Geometry and Vertex attribute instancing
- > Parallel pixel processing
- > Early-z reject: Fast rejection of occluded pixels acts as multiplier on pixel shader and texture performance while saving power and bandwidth
- > Video protection region

2.2 PVA and DLA Cluster

This cluster consists of two primary engines: Programmable Vision Accelerator (PVA) and Deep Learning Accelerator (DLA).

The Orin PVA is the second generation of NVIDIA's vision DSP architecture. This is an application-specific instruction vector processor that targets computer-vision along with virtual and mixed reality applications. These are some key areas where PVA capabilities are a good match for algorithmic domains that need to have a predictable processing capability, at low power and low latency.

A PVA cluster has the following components:

- > Dual Vector Processing Units (VPU) with vector cores, instruction cache, and three vector data memories. Each unit has seven VLIW slots including both scalar and vector instructions.
- > 384 KBytes of triple-port memory for each VPU.

- > Dual DMA engines with 5-dimensional addressing capability, each with 16 independent hardware channels, and sophisticated control to have both hardware and software events trigger the DMA channels.
- > 1 MByte local L2 cache.
- > Cortex-R5 subsystem for PVA control and task monitoring.

Table 2-2: PVA Operation

Module	PVA	Maximum Frequency
Orin NX 16GB	1	1190.4 MHz
Orin NX 8GB	1	1190.4 MHz

The DLA is a fixed function engine used to accelerate inference operations on convolutional neural networks (CNNs). Orin implements the second generation of NVIDIA's DLA architecture. The DLA supports accelerating CNN layers such as convolution, deconvolution, activation, pooling, local response normalization, and fully connected layers.

Specific optimizations include:

- > Structured Sparsity.
- > Depth-wise Convolution capability.
- > A dedicated Hardware Scheduler to maximize efficiency.

Table 2-3: DLA Operation

Module	DLA	Maximum Frequency
Orin NX 16GB	2	614 MHz 1229 MHz (MAXN_SUPER)
Orin NX 8GB	1	610 MHz 1229 MHz (MAXN_SUPER)

2.3 Cortex CPU Complex

The CPU cluster is comprised of eight cores of Arm Cortex-A78AE Core processors organized as multiple quad-core clusters. Clusters contain private L1 and L2 caches per core, a Snoop Control Unit (SCU), and a cluster-level L3 cache (shared by the four cores), an interconnect fabric and debug support modules (CoreSight).

Features:

- > Superscalar, variable-length, out-of-order pipeline.
- > Dynamic branch prediction with Branch Target Buffer (BTB) and a branch direction predictor using previous branch history, a return stack, a static predictor, and an indirect predictor.
- > A 1.5K entry, 4-way skewed associative L0 Macro-OP (MOP) cache.
- > 32-entry fully-associative L1 instruction TLB with native support for 4KB, 16KB, 64KB, and 2MB page sizes.
- > 32-entry fully-associative L1 data TLB with native support for 4KB, 16KB, 64KB, 2MB, and 512MB page sizes.
- > 4-way set-associative unified 1024-entry Level 2 (L2) TLB in each processor.

- > L1 caches – separate 64 KB I-cache and 64 KB D-cache for each core.
- > L2 cache – a unified, 8-way set associative, 256 KB L2 cache per core.
- > 40-bit Physical Address (PA)

Cortex-A78AE CPU supports:

- > Full implementation of Armv8.2-A architecture instruction set and select instructions from Armv8.3-A, Armv8.4-A, and Armv8.5-A extensions.
- > Embedded Trace Microcell (ETM) based on the ETMv4.2 architecture.
- > Performance Monitor Unit (PMU) based on the PMUv3 architecture.
- > CoreSight for debugging based on CoreSightv3 architecture.
- > Cross Trigger Interface (CTI) for multiprocessor debugging.
- > Generic Timer Interface based on Armv8-A architecture and 64-bit count input from external system counter.
- > Cryptographic Engine for crypto function support.
- > Interface to an external Generic Interrupt Controller based on GICv3 architecture.
- > Power management with multiple power domains.

Table 2-4: CPU Operation

Module	CPU Cores	CPU Maximum Frequency
Orin NX 16GB	8	2 GHz
Orin NX 8GB	6	2 GHz

2.4 Memory Subsystem

16GB 128-bit LPDDR5 DRAM is used on the Jetson Orin NX 16GB, and 8GB 128-bit LPDDR5 DRAM is used in the Jetson Orin NX 8GB. It supports the following:

- > Secure external memory access using TrustZone technology.
- > System MMU
- > Maximum operating frequency: 3200 MHz

The Memory Subsystem (MSS) provides access to local DRAM, SysRAM, and provides a SyncPoint Interface for inter-processor signaling. The MSS supports full-speed I/O coherence by routing requests through a scalable coherence fabric. It also supports a comprehensive set of safety and security mechanisms.

Structurally, the MSS consists of:

- > MSS Data Backbone - routes requests from clients to the MSS Hub and responses from MSS Hub to the clients.
- > MSS Hub - receives and arbitrates among client requests, performs SMMU translation, and sends requests to MCF.
- > Memory Controller Fabric (MCF) - performs security checks, feeds I/O coherent requests to the Scalable Coherence Fabric (SCF), and directs requests to the multiple memory channels.

- > Memory Controller (MC) Channels - row sorter/arbiter and DRAM controllers.
- > DRAM I/O - channel-to-pad fabric, DRAM I/O pads, and PLLs.

Jetson Orin NX provides three independent column address bits to each sub-partition, allowing it access different 32-byte sectors of a Group of Bytes (GOB) between the sub-partitions. It provides connections between a wide variety of clients, supporting their bandwidth, latency, quality-of-service needs, and any special ordering requirements that are needed. The MSS supports a variety of security and safety features and address translation for clients that use virtual addresses.

Features:

- > LPDDR5: x64 DRAM chips
- > 128-bit wide data bus.
- > Low latency path and fast read/response path support for the CPU complex cluster.
- > Support for low-power modes:
 - Software controllable entry/exit from self-refresh, power down, and deep power down.
 - Hardware dynamic entry/exit from power down, self-refresh.
 - Pads use DPD mode during idle periods.
- > High-bandwidth interface to the integrated Ampere GPU.
- > Full-speed I/O coherence with bypass for Isochronous (ISO) traffic.
- > System Memory-Management Unit (SMMU) for address translation based on the Arm SMMU-500.
- > High-bandwidth PCIe ordered writes.
- > AES-XTS encryption with 128-bit key.

2.5 Memory

The Jetson Orin NX 16GB integrates 16 GB 128-bit LPDDR5 DRAM, and Jetson Orin NX 8GB integrates 8GB LPDDR5 DRAM. The maximum frequency of Jetson Orin NX is 3200 MHz, and has a theoretical peak memory bandwidth of 102 GB/s.

The Memory Controller (MC) maximizes memory utilization while providing minimum latency access for critical CPU requests. An arbiter is used to prioritize requests, optimizing memory access efficiency and utilization and minimizing system power consumption. The MC provides access to main memory for all internal devices. It provides an abstract view of memory to its clients via standardized interfaces, allowing the clients to ignore details of the memory hierarchy. It optimizes access to shared memory resources, balancing latency and efficiency to provide best system performance, based on programmable parameters.

Features:

- > TrustZone (TZ) Secure and OS-protection regions.
- > System Memory Management Unit.
- > Dual CKE signals for dynamic power down per device.
- > Dynamic Entry/Exit from Self-Refresh and Power Down states.

2.6 Video Input Interfaces

2.6.1 MIPI Camera Serial Interface (CSI)

Standard
MIPI CSI 2.0 Receiver specification
MIPI D-PHY® 2.1 Physical Layer specification

The NVIDIA Camera Serial Interface (NVCSI) works with the Video Input (VI) unit to capture an image from a sensor, where NVCSI is a source of pixel data to VI. NVCSI works in streaming mode while VI captures the required frames using a single-shot mode of operation. All sync point generation for software is handled at VI; the delay between NVCSI and VI is negligible in software terms. NVCSI does not have a direct memory port, instead it sends the pixel data to memory through the VI.

Fifth-generation NVIDIA camera solution (NVCSI 2.0, VI 6.0, and ISP 6.x) provides a combination host that supports enhanced MIPI D-PHY (with lane deskew support) physical layer options in two 4-lane or four 2-lane configurations; or combinations of these. Orin NX can support up to eight virtual channels (VC) and supports data type interleaving.

- > Virtual Channel Interleaving: VCs are defined in the CSI-2 specification and are useful when supporting multiple camera sensors. With the VC capability, a one-pixel parser (PP) can de-interleave up to six image streams.
- > Data Type Interleaving: In HDR line-by-line mode, the sensor can output long/short exposure lines using the same VC and a different programmable data type (DT).
- > Frequency Target: The parallel pixel processing rate, measured in pixels-per-clock (PPC), is increased to allow higher throughput and lower clock speeds. To support higher bandwidth without increasing the operating frequency, the host processes multiple pixels in one clock. NVCSI is capable of processing four PPCs when bits-per-pixel (BPP) is greater than 16, and eight PPC when BPP is less than or equal to 16.
- > With the new streaming mode in NVCSI, one PP can handle all traffic (embedded data and image data) from one camera device, including 16 VCs.

Features:

- > Supports the MIPI D-PHY v2.1 physical layer option:
- > MIPI D-PHY supports up to 2.5 Gbits/sec per pair, for an aggregate bandwidth of 20 Gbps from eight pairs
- > Based on MIPI CSI-2 v3.0 protocol stack
- > Includes six-pixel parsers (PP)
- > Supports up to 16 virtual channels per active PP
- > Supported input data formats:
 - RGB: RGB888, RGB666, RGB565, RGB555, RGB444
 - YUV: YUV422-8b, YUV420-8b (legacy), YUV420-8b, YUV422-10b, YUV420-10b
 - RAW: RAW6, RAW7, RAW8, RAW10, RAW12, RAW14, RAW16, RAW20

- DPCM (predictor 1): 14-10-14, 14-8-14, 12-8-12, 12-7-12, 12-6-12, 12-10-12, 10-8-10, 10-7-10, 10-6-10 (Predictor 2 not supported)
- > Data Type Interleave support

Table 2-5: CSI Pin Descriptions

Pin #	Signal Name	Description	Direction	Pin Type
10	CSI0_CLK_N	Camera, CSI 0 Clock-	Input	MIPI D-PHY
12	CSI0_CLK_P	Camera, CSI 0 Clock+	Input	MIPI D-PHY
4	CSI0_DO_N	Camera, CSI 0 Data 0-	Input	MIPI D-PHY
6	CSI0_DO_P	Camera, CSI 0 Data 0+	Input	MIPI D-PHY
16	CSI0_D1_N	Camera, CSI 0 Data 1-	Input	MIPI D-PHY
18	CSI0_D1_P	Camera, CSI 0 Data 1+	Input	MIPI D-PHY
9	RSVD (CSI1_CLK_N)	Camera, CSI 1 Clock-	Input	MIPI D-PHY
11	RSVD (CSI1_CLK_P)	Camera, CSI 1 Clock+	Input	MIPI D-PHY
3	CSI1_DO_N	Camera, CSI 1 Data 0-	Input	MIPI D-PHY
5	CSI1_DO_P	Camera, CSI 1 Data 0+	Input	MIPI D-PHY
15	CSI1_D1_N	Camera, CSI 1 Data 1-	Input	MIPI D-PHY
17	CSI1_D1_P	Camera, CSI 1 Data 1+	Input	MIPI D-PHY
28	CSI2_CLK_N	Camera, CSI 2 Clock-	Input	MIPI D-PHY
30	CSI2_CLK_P	Camera, CSI 2 Clock+	Input	MIPI D-PHY
22	CSI2_DO_N	Camera, CSI 2 Data 0-	Input	MIPI D-PHY
24	CSI2_DO_P	Camera, CSI 2 Data 0+	Input	MIPI D-PHY
34	CSI2_D1_N	Camera, CSI 2 Data 1-	Input	MIPI D-PHY
36	CSI2_D1_P	Camera, CSI 2 Data 1+	Input	MIPI D-PHY
27	CSI3_CLK_N	Camera, CSI 3 Clock-	Input	MIPI D-PHY
29	CSI3_CLK_P	Camera, CSI 3 Clock+	Input	MIPI D-PHY
21	CSI3_DO_N	Camera, CSI 3 Data 0-	Input	MIPI D-PHY
23	CSI3_DO_P	Camera, CSI 3 Data 0+	Input	MIPI D-PHY
33	CSI3_D1_N	Camera, CSI 3 Data 1-	Input	MIPI D-PHY
35	CSI3_D1_P	Camera, CSI 3 Data 1+	Input	MIPI D-PHY

Table 2-6: Camera Pin Descriptions

Pin #	Signal Name	Description	Direction	Pin Type
116	CAM0_MCLK	Camera 0 Reference Clock	Output	CMOS - 1.8V
114	CAM0_PWDN	Camera 0 Powerdown or GPIO	Output	CMOS - 1.8V
122	CAM1_MCLK	Camera 1 Reference Clock	Output	CMOS - 1.8V
120	CAM1_PWDN	Camera 1 Powerdown or GPIO	Output	CMOS - 1.8V

2.6.2 Video Input (VI)

The VI block receives data from the CSI receiver and prepares it for presentation to system memory or the dedicated image signal processor execution resources. The VI block provides formatting for RGB, YCbCr, and raw Bayer data in support of several camera user models. These models include single and multi-camera systems, which may have up to six active streams. The input streams are obtained from MIPI compliant CMOS sensor camera modules.

2.6.3 Image Signal Processor (ISP)

The ISP module takes data from the VI/CSI module or memory in raw Bayer format and processes it to YUV output. The imaging subsystem supports raw (Bayer) image sensors up to 24 million pixels. Advanced image processing is used to convert input to YUV data and remove artifacts introduced by high-megapixel CMOS sensors and optics with up to 30-degree CRA.

The ISP in Orin NX supports a max frequency of 1011.2 MHz, with a maximum throughput of 1.75 GPixel/s.

Features:

- > Flexible post-processing architecture for supporting custom computer vision and computational imaging operations.
- > Hardware noise reduction
- > Black-level compensation
- > Lens-shading compensation
- > Bad pixel correction
- > Edge enhancement
- > Color and gamma correction
- > Global and local tone mapping
- > Color-space conversion (RGB to YUV)

2.7 Sensor Processing Engine

The Cortex-R5 processor in the Always On (AON) block is also referred to as the Sensor Processing Engine (SPE). The AON cluster provides all the necessary hardware features to support low power sensor management and wake use cases. The cluster consists of an Arm Cortex-R5 processor core with a tightly coupled RAM, supporting peripherals (such as timers and an interrupt controller), various I/O controller peripherals, and routing logic.

AON Cortex-R5 implementation:

- > Armv7-R ISA
- > Integrated instruction and data caches
- > Tightly coupled memory (TCM) interface for local SRAM
- > Vectored interrupt support
- > 64-bit AXI Initiator interface for DRAM requests
- > 32-bit AXI Initiator interface for MMIO requests

- > 32-bit AHB Initiator interface for Arm Vectored Interrupt Controller (AVIC) access
- > AXI Target interface for DMA access to the local SRAM

2.8 Security Subsystem

This subsystem is comprised of the following:

- > Platform Security Controller (PSC)
- > Security Engine (SE)

2.8.1 Platform Security Controller

The Platform Security Controller (PSC) is a highly secure subsystem to protect and manage assets (keys, fuses, functions, and features) within the SoC, provide trusted services, increase resilience against attacks on the SoC, and provide a greater level of protection against software and hardware attacks on the subsystem itself.

Key Management and Protection: The PSC is the only mechanism with access to the most critical secrets in the chip. This subsystem represents the highest level of protection in Orin and the subsystem itself is highly resilient to a wide range of software and hardware attacks.

Trusted Services: The primary PSC services include secure authentication (for example, during SoC secure boot), provisioning of additional keys, ID, data, key access and management, random number generation, and trusted time reporting.

Security Monitor: The PSC is responsible for periodic security housekeeping tasks, including continually assessing the security status of the SoC, actively monitor known or potential attack patterns (for example, such as voltage glitching or thermal attacks), mitigate hardware attack risks, and to take action in the case of a detected attack. The PSC has the ability to accept updates as workarounds to improve the robustness of the system in the field.

2.8.2 Security Engine

The Security Engine (SE) provides hardware acceleration for cryptographic algorithms. There are two instances of SE available for software usage:

- > TZ-SE: accessible only by TrustZone software.
- > NS/TZ-SE: configurable to be accessible only by TrustZone software or TrustZone and non-secure software.

The SE provides hardware acceleration for various cryptographic operations and hardware assisted Key protection. The crypto operations that the SE provides can be used by software to build crypto protocols and security features. These crypto operations are based on Crypto algorithms approved by the National Institute of Standards and Technology (NIST).

The SE supports the following:

- > NIST-compliant asymmetric, symmetric cryptography and hashing
- > Side channel countermeasures [AES/RSA/ECC]
- > Independent channels for parallelization

- > Hardware Key Access Controls (KAC): Rule-based, hardware-enforced access control for symmetric keys
- > 16x AES, 4x RSA/ECC key slots
- > Hardware key isolation (only AES keyslots)
- > Read protection (only AES keyslots)
- > Hardware keyslot functions
- > Key wrap and unwrap functionality (AES -> AES keyslot)
- > Key derivation into a keyslot (KDF -> AES keyslot)
- > Random key generation (RNG -> AES keyslot)

2.9 Display Controller

The NVIDIA Jetson Orin NX provides 1x HDMI and DP port. The HDMI and VESA DisplayPort (DP) interfaces share the same set of interface pins.

HDMI provides a unified method of transferring both audio and video data. The HDMI block receives video from either display controller and audio from a separate high-definition audio (HDA) controller; it combines and transmits them as appropriate.

Supported HDMI features are:

- > Compliant to HDMI 2.0 (up to 594 MHz pixel clock rate)
 - Support 8/10/12 bpc RGB, YUV444, YUV420, or YUV422 (HDMI 2.0 only)
- > Compatible with HDMI 2.1 Specification
- > HDCP 2.2 and 1.4
- > On-chip HDCP key storage, no external SecureROM required.
- > Multichannel audio from HDA controller, up to eight channels 192 kHz 24-bit.
- > 24-bit RGB and 24-bit YUV444 (HDMI) pixel formats.



Note: HDCP is disabled by default. Contact NVIDIA for activation.

VESA DisplayPort (DP) is a digital display interface often used to connect a video source to a display device over a cable, in consumer or commercial applications.

Supported DisplayPort features are:

- > Compliant to the DisplayPort 1.4a Specification
 - Support 16 bpp YUV422
 - Support 18 bpp RGB
 - Support 24 bpp RGB/YUV444
 - Support 30 bpp RGB/YUV444
 - Support 36 bpp RGB/YUV444
- > Support up to 1080 MHz display clock
- > Support for 1/2/4 lanes
- > Support for following bit rates:

- RBR (Reduced Bit Rate, 1.62 Gbps)
- HBR (High Bit Rate, 2.7 Gbps)
- HBR2 (High Bit Rate 2, 5.4 Gbps)
- HBR3 (High Bit Rate 3, 8.1 Gbps)
- > Multi-Stream Transport (MST)
- > Support for two to eight channels of audio streaming up to 96 kHz sample rate
- > Support additional eDP 1.4 features:
 - Additional link rates (2.16, 2.43, 3.24, 4.32 Gbps)
 - Enhanced framing
 - Power sequencing
 - Reduced AUX timing
 - Reduced main voltage swing
 - Alternate Seed Scrambler Reset (ASSR) for internal eDP panels

2.10 High-Definition Audio-Video Subsystem

Standard
High-Definition Audio Specification Version 1.0a

The HD Audio-Video Subsystem uses a collection of functional blocks to off-load audio and video processing activities from the CPU complex, resulting in fast, fully concurrent, and highly efficient operation. This subsystem is comprised of the following:

- > Multi-standard video decoder
- > Multi-standard video encoder
- > JPEG processing block
- > Video Image Compositor (VIC)
- > Audio Processing Engine (APE)
- > High-Definition Audio (HDA)

2.10.1 Multi-Standard Video Decoder

The Jetson Orin NX incorporates the NVIDIA Multi-Standard Video Decoder (NVDEC). This video decoder accelerates video decode, supporting low resolution mobile content, Standard Definition (SD), High Definition (HD) and UltraHD (8K, 4K, etc.) video profiles. The video decoder is designed to be extremely power efficient without sacrificing performance. The video decoder communicates with the memory controller through the video DMA which supports a variety of memory format output options. For low-power operations, the video decoder can operate at the lowest possible frequency while maintaining real-time decoding using dynamic frequency scaling techniques.

Video decode standards supported: H.265 (HEVC), H.264, VP9, VP8, AV1, MPEG-4, MPEG-2, and VC-1.

Table 2-7: Supported Video Decode Streams

Standard	Profile(s)	Resolution (Maximum Number of Streams)	Throughput (Up to)
H.264	Baseline, Main, High	4K60 (1) 4K30 (2) 1080p60 (5) 1080p30 (11)	720 MP/S
	High 444, High 444 Predictive, MVC (per view considering two views) *	4K30 (1) 1080p60 (2) 1080p30 (5)	360 MP/s
H.265 (HEVC)	Main, Main10	8K30 (1) 4K60 (2) 4K30 (4) 1080p60 (9) 1080p30 (18)	1100 MP/S
	Main 444, Main 444 10, MV (per view)	4K60 (1) 4K30 (2) 1080p60 (4) 1080p30 (9)	550 MP/S
AV1	Main Profile	8K30 (1) 4K60 (2) 4K30 (4) 1080p60 (10) 1080p30 (20)	1000 MP/S
VP9	Profile 0, Profile 2	4K60 (1) 4K30 (3) 1080p60 (7) 1080p30 (15)	1000 MP/S
* Maximum throughput half for YUV444 – as compared to YUV420			

2.10.2 Multi-Standard Video Encoder

The Jetson Orin NX incorporates the NVIDIA Multi-Standard Video Encoder (NVENC). This multi-standard video encoder enables full hardware acceleration of various encoding standards. It performs high-quality video encoding operations for mobile applications such as video recording and video conferencing. The encode processor is designed to be extremely power efficient without sacrificing performance.

Table 2-8: Supported Video Encode Streams

Standard	Profile(s)	Resolution (Maximum Number of Streams)	Throughput (Up to)
H.264	UHP	4K60 (1) 4K30 (2) 1080p60 (5) 1080p30 (11)	680 MP/s
	HP	4K30 (1) 1080p60 (3) 1080p30 (7)	470 MP/S
	HQ	1080p60 (1) 1080p30 (3)	220 MP/s
H.265 (HEVC)	UHP	4K60 (1) 4K30 (3) 1080p60 (6) 1080p30 (12)	800 MP/S
	HP	4K30 (1) 1080p60 (3) 1080p30 (6)	400 MP/S
	HQ	1080p60 (1) 1080p30 (2)	140 MP/s
AV1	UHP	4K60 (1) 4K30 (3) 1080p60 (6) 1080p30 (12)	750 MP/S
	HQ	4K30 (1) 1080p60 (3) 1080p30 (6)	380 MP/s

Features:

- > Timestamp for Audio/Video Sync
- > CBR and VBR rate control (supported in firmware)
- > Programmable intra-refresh for error resiliency
- > Macro-block based and bit based packetization (multiple slice)
- > Motion estimation (ME) only mode

2.10.3 JPEG Processing Block

The JPEG processing block is responsible for JPEG (de)compression calculations (based on JPEG still image standard), image scaling, decoding (YUV420, YUV422H/V, YUV444, YUV400), and color space conversion (RGB to YUV).

The processing block consists of a hardware engine with two instances of NVJPEG hardware:

- > 2x NVJPEG
- > Perf: 2x 600Mpix/Sec

Table 2-9: NVJPEG Streams per Instance

NVJPEG	Compression Ratio	Throughput (Up to)	Number of 1080p30 Streams	Number of 4K30 Streams
Decode	6:1	756 MP/S	12	3x
	10:1	952 MP/S	15	3x
Encode	6:1	922 MP/S	15	3x
	10:1	1253 MP/S	20	5x

Notes:

2x NVJPG engines are present in Jetson Orin. The data is for single instance of NVJPG. Results at 880 MHz for 4:2:0 and aggregate across two NVJPEG blocks. Throughput for 4:4:4 will be roughly half of the above.

Input (encode) formats:

- > Pixel width: 8 bpc
- > Subsample format: YUV420
- > Resolution (up to): 16Kx16K
- > Pixel pack format
 - Semi-planar/Planar for 420

Output (decode) formats:

- > Pixel width 8 bpc
- > Resolution (up to): 16Kx16K
- > Pixel pack format
 - Semi-planar/Planar for YUV420
 - YUY2/Planar for 422H/422V
 - Planar for YUV444/YUV400
 - Interleaved RGBA

2.10.4 Video Image Compositor (VIC)

VIC implements various 2D image and video operations in a power-efficient manner. It handles various system UI scaling, blending, rotation operations, video post-processing functions needed during video playback, and advanced de-noising functions used for camera capture.

Features:

- > High-quality Deinterlacing
- > Inverse Teleciné

- > Temporal Noise Reduction
 - New Bilateral Filter as spatial filter
 - Improved TNR3 algorithm
- > Scaling
- > Color Conversion
- > Memory Format Conversion
- > Blend/Composite
- > 2D Bit BLIT operation
- > Rotation
- > Geometry Transform Processing
 - Programmable nine-points controlled warp patch for distortion correction
 - Real-time on-the-fly position generation from sparse warp map surface
 - Pincushion/barrel/moustache distortion correction
 - Distortion correction of 180- and 360-degree wide FOV lens
 - Scene perspective orientation adjustment with IPT
 - Full warp map capability
 - Non-fixed Patch size with 4x4 regions
 - External Mask bit map surface

2.10.5 Audio Processing Engine (APE)

The Audio Processing Engine (APE) is a self-contained unit with dedicated audio clocking that enables Ultra Low Power (ULP) audio processing. Software-based post processing effects enable the ability to implement custom audio algorithms.

Features:

- > 96 KB Audio RAM
- > Audio Hub (AHUB) I/O Modules
 - 2x I2S Audio Hub (AHUB) Internal Modules
- > Sample Rate converter
- > Mixer
- > Audio Multiplexer
- > Audio De-multiplexer
- > Master Volume Controller
- > Multi-Channel IN/OUT
 - Digital Audio Mixer: 10-in/5-out
 - Up to eight channels per stream
 - Simultaneous Multi-streams
 - Flexible stream routing
 - Parametric equalizer: up to 12 bands
 - Low latency sample rate conversion (SRC) and high-quality asynchronous sample rate conversion (ASRC)

2.10.6 High-Definition Audio (HDA)

Standard
Intel High-Definition Audio Specification Revision 1.0a

The Jetson Orin NX implements an industry-standard High-Definition Audio (HDA) controller. This controller provides a multi-channel audio path to the HDMI interface. The HDA block also provides an HDA-compliant serial interface to an audio codec. Multiple input and output streams are supported.

Features:

- > Supports HDMI 2.0 and DP1.4
- > Support up to two audio streams for use with HDMI/DP
- > Supports striping of audio out across 1,2,4[a] SDO lines
- > Supports DVFS with maximum latency up to 208 μ s for eight channels
- > Supports two internal audio codecs
- > Audio Format Support
 - Uncompressed Audio (LPCM): 16/20/24 bits at 32/44.1/48/88.2/96/176.4/192[b] kHz
 - Compressed Audio format: AC3, DTS5.1, MPEG1, MPEG2, MP3, DD+, MPEG2/4 AAC, TrueHD, DTS-HD
 - [a] Four SDO lines: cannot support one stream, 48 kHz, 16-bits, two channels; for this case, use a one or two SDO line configuration.
 - [b] DP protocol sample frequency limitation: cannot support >96 kHz; that is, it does not support 176.4 kHz and 196 kHz.

2.11 Interface Descriptions

The following sections outline the interfaces available on the Jetson Orin NX module and details the module pins used to interact with and control each interface.

2.11.1 Universal Serial Bus (USB)

Standard	Notes
Universal Serial Bus Specification Revision 3.2 Gen1 and Gen2	-
Universal Serial Bus Specification Revision 2.0	<ul style="list-style-type: none"> > Modes: Host and Device (Only USB 2.0 port USB0 supports RCM, Host, Device Mode. All other ports are Host only) > Speeds: Low, Full, and High > USB Battery Charging 1.2 Specifications
Enhanced Host Controller Interface Specification for Universal Serial Bus revision 1.0	-

An xHCI/Device controller (named XUSB) supports the xHCI programming model for scheduling transactions and interface managements as a host that natively supports USB 3.2, USB 2.0, and

USB 1.1 transactions with its USB 3.2 and USB 2.0 interfaces. The XUSB controller supports USB 2.0 L1 and L2 (suspend) link power management and USB 3.2 U1, U2, and U3 (suspend) link power managements. The XUSB controller supports remote wakeup, wake on connect, wake on disconnect, and wake on overcurrent in all power states, including sleep mode.

2.11.1.1 USB 2.0 Operation

Each USB 2.0 port (3x) operates in USB 2.0 high-speed mode when connecting directly to a USB 2.0 peripheral and operates in USB 1.1 full- and low-speed modes when connecting directly to a USB 1.1 peripheral. When operating in High-Speed mode, each USB 2.0 port is allocated with one High-Speed unit bandwidth. Approximately a 480 Mb/s bandwidth is allocated to each USB 2.0 port. All USB 2.0 ports operating in full- or low-speed modes share one full- and low-speed bus instance, which means 12 Mb/s theoretical bandwidth is distributed across these ports.

Table 2-10: USB 2.0 Pin Descriptions

Pin #	Signal Name	Description	Direction	Pin Type
109	USB0_D_N	USB 2.0 Port 0 Data-	Bidir	USB PHY
111	USB0_D_P	USB 2.0 Port 0 Data+	Bidir	USB PHY
115	USB1_D_N	USB 2.0 Port 1 Data-	Bidir	USB PHY
117	USB1_D_P	USB 2.0 Port 1 Data+	Bidir	USB PHY
121	USB2_D_N	USB 2.0 Port 2 Data-	Bidir	USB PHY
123	USB2_D_P	USB 2.0 Port 2 Data+	Bidir	USB PHY

2.11.1.2 USB 3.2 Operation

In host mode, the USB3.2 host controller supports Gen2 Super Speed+, 10 Gbps transfer rates. In device mode, the USB3.2 controller supports Gen1 Super Speed.



Note: There is an internal USB 3.2 hub for ports 0 and 1. The hub supports 10Gbps bandwidth which would be shared between the two ports.

Table 2-11: USB 3.2 Pin Descriptions

Pin #	Signal Name	Description	Direction	Pin Type
161	USBSS0_RX_N	USB SS Receive- (USB 3.2 Port #0)	Input	USB SS PHY
163	USBSS0_RX_P	USB SS Receive+ (USB 3.2 Port #0)	Input	USB SS PHY
166	USBSS0_TX_N	USB SS Transmit- (USB 3.2 Port #0)	Output	USB SS PHY
168	USBSS0_TX_P	USB SS Transmit+ (USB 3.2 Port #0)	Output	USB SS PHY
39	USBSS1_RX_N	USB SS Receive- (USB 3.2 Port #1)	Input	USB SS PHY
41	USBSS1_RX_P	USB SS Receive+ (USB 3.2 Port #1)	Input	USB SS PHY
45	USBSS1_TX_N	USB SS Transmit- (USB 3.2 Port #1)	Output	USB SS PHY
47	USBSS1_TX_P	USB SS Transmit+ (USB 3.2 Port #1)	Output	USB SS PHY
51	USBSS2_RX_N	USB SS Receive- (USB 3.2 Port #2)	Input	USB SS PHY

Pin #	Signal Name	Description	Direction	Pin Type
53	USBSS2_RX_P	USB SS Receive+ (USB 3.2 Port #2)	Input	USB SS PHY
57	USBSS2_TX_N	USB SS Transmit- (USB 3.2 Port #2)	Output	USB SS PHY
59	USBSS2_TX_P	USB SS Transmit+ (USB 3.2 Port #2)	Output	USB SS PHY

2.11.2 PCI Express (PCIe)

Standard	Notes
PCI Express Base Specification Revision 4.0	

The Jetson Orin NX module integrates four PCIe controllers supporting:

- > Connections to two interfaces, 3x1 (or 1x2 + 1x1) + 1x4 GEN4.
- > x1 and x2 (supports Root Port only), x4 (supports Root Port or Endpoint modes) upstream and downstream AXI interfaces that serve as the control path from the Jetson Orin NX to the external PCIe device.
- > Gen4 (16 GT/s) supported on all controllers/lanes.
- > Four PCIe controllers, seven lanes for a total of 144 GT/s.
- > Controller #0 can operate in x1, x2, or x4 mode.
- > Controller #1 operates in x1 mode only.
- > Controller #2 can operate in x1, x2 mode.
- > Controller #3 is available if Controller #2 is not used or only used in x1 mode. In these cases, Controller #3 can operate in x1 mode.

Table 2-12: PCIe Pin Descriptions

Pin #	Signal Name	Description	Direction	Pin Type
131	PCIE0_RX0_N	PCIe 0 Receive 0- (PCIe Ctrl #4 Lane 0)	Input	PCIe PHY
133	PCIE0_RX0_P	PCIe 0 Receive 0+ (PCIe Ctrl #4 Lane 0)	Input	PCIe PHY
137	PCIE0_RX1_N	PCIe 0 Receive 1- (PCIe Ctrl #4 Lane 1)	Input	PCIe PHY
139	PCIE0_RX1_P	PCIe 0 Receive 1+ (PCIe Ctrl #4 Lane 1)	Input	PCIe PHY
149	PCIE0_RX2_N	PCIe 0 Receive 2- (PCIe Ctrl #4 Lane 2)	Input	PCIe PHY
151	PCIE0_RX2_P	PCIe 0 Receive 2+ (PCIe Ctrl #4 Lane 2)	Input	PCIe PHY
155	PCIE0_RX3_N	PCIe 0 Receive 3- (PCIe Ctrl #4 Lane 3)	Input	PCIe PHY
157	PCIE0_RX3_P	PCIe 0 Receive 3+ (PCIe Ctrl #4 Lane 3)	Input	PCIe PHY
134	PCIE0_TX0_N	PCIe 0 Transmit 0- (PCIe Ctrl #4 Lane 0)	Output	PCIe PHY
136	PCIE0_TX0_P	PCIe 0 Transmit 0+ (PCIe Ctrl #4 Lane 0)	Output	PCIe PHY
140	PCIE0_TX1_N	PCIe 0 Transmit 1- (PCIe Ctrl #4 Lane 1)	Output	PCIe PHY
142	PCIE0_TX1_P	PCIe 0 Transmit 1+ (PCIe Ctrl #4 Lane 1)	Output	PCIe PHY
148	PCIE0_TX2_N	PCIe 0 Transmit 2- (PCIe Ctrl #4 Lane 2)	Output	PCIe PHY
150	PCIE0_TX2_P	PCIe 0 Transmit 2+ (PCIe Ctrl #4 Lane 2)	Output	PCIe PHY
154	PCIE0_TX3_N	PCIe 0 Transmit 3- (PCIe Ctrl #4 Lane 3)	Output	PCIe PHY

Pin #	Signal Name	Description	Direction	Pin Type
156	PCIE0_TX3_P	PCIe 0 Transmit 3+ (PCIe Ctrl #4 Lane 3)	Output	PCIe PHY
181	PCIE0_RST*	PCIe 0 Reset (PCIe Ctrl #4). 4.7kΩ pull-up to 3.3V on the module. Output when Orin NX is Root Port or input when Orin NX is Endpoint.	Bidir	Open Drain 3.3V
180	PCIE0_CLKREQ*	PCIe 0 Clock Request (PCIe Ctrl #4). 47kΩ pull-up to 3.3V on the module. Input when Orin NX is Root Port or output when Orin NX is Endpoint.	Bidir	Open Drain 3.3V
160	PCIE0_CLK_N	PCIe #0 Reference Clock- (reference clock input when Orin NX is an Endpoint).	Bidir	PCIe PHY
162	PCIE0_CLK_P	PCIe #0 Reference Clock+ (reference clock input when Orin NX is an Endpoint).	Bidir	PCIe PHY
167	PCIE1_RX0_N	PCIe 1 Receive 0- (PCIe Ctrl #1 Lane 0)	Input	PCIe PHY
169	PCIE1_RX0_P	PCIe 1 Receive 0+ (PCIe Ctrl #1 Lane 0)	Input	PCIe PHY
172	PCIE1_TX0_N	PCIe 1 Transmit 0- (PCIe Ctrl #1 Lane 0)	Output	PCIe PHY
174	PCIE1_TX0_P	PCIe 1 Transmit 0+ (PCIe Ctrl #1 Lane 0)	Output	PCIe PHY
183	PCIE1_RST*	PCIe 1 Reset (PCIe Ctrl #1). 4.7kΩ pull-up to 3.3V on the module.	Output	Open Drain 3.3V
182	PCIE1_CLKREQ*	PCIe 1 Clock Request (PCIe Ctrl #1). 47kΩ pull-up to 3.3V on the module.	Bidir	Open Drain 3.3V
173	PCIE1_CLK_N	PCIe 1 Reference Clock- (PCIe Ctrl #1)	Output	PCIe PHY
175	PCIE1_CLK_P	PCIe 1 Reference Clock+ (PCIe Ctrl #1)	Output	PCIe PHY
40	PCIE2_RX0_N	PCIe 2 Receive 0- (PCIe Ctrl #7 Lane 0)	Input	PCIe PHY
42	PCIE2_RX0_P	PCIe 2 Receive 0+ (PCIe Ctrl #7 Lane 0)	Input	PCIe PHY
46	PCIE2_TX0_N	PCIe 2 Transmit 0- (PCIe Ctrl #7 Lane 0)	Output	PCIe PHY
48	PCIE2_TX0_P	PCIe 2 Transmit 0+ (PCIe Ctrl #7 Lane 0)	Output	PCIe PHY
58	PCIE2_RX1_N (PCIE3_RX0_N)	PCIe 2 Receive 1- (PCIe Ctrl #7 Lane 1) or PCIe 3 Receive 0- (PCIe Ctrl #9 Lane 0)	Input	PCIe PHY
60	PCIE2_RX1_P (PCIE3_RX0_P)	PCIe 2 Receive 1+ (PCIe Ctrl #7 Lane 1) or PCIe 3 Receive 0+ (PCIe Ctrl #9 Lane 0)	Input	PCIe PHY
64	PCIE2_TX1_N (PCIE3_TX0_N)	PCIe 2 Transmit 1- (PCIe Ctrl #7 Lane 1) or PCIe 3 Transmit 0- (PCIe Ctrl #9 Lane 0)	Output	PCIe PHY
66	PCIE2_TX1_P (PCIE3_TX0_P)	PCIe 2 Transmit 1+ (PCIe Ctrl #7 Lane 1) or PCIe 3 Transmit 0+ (PCIe Ctrl #9 Lane 0)	Output	PCIe PHY
52	PCIE2_CLK_N	PCIe 2 Reference Clock- (PCIe Ctrl #7)	Output	PCIe PHY
54	PCIE2_CLK_P	PCIe 2 Reference Clock+ (PCIe Ctrl #7)	Output	PCIe PHY
219	PCIE2_RST*	PCIe 2 Reset (PCIe Ctrl #7). 4.7kΩ pull-up to 3.3V on the module.	Output	Open Drain 3.3V
221	PCIE2_CLKREQ*	PCIe 2 Clock Request (PCIe Ctrl #7). 47kΩ pull-up to 3.3V on the module.	Bidir	Open Drain 3.3V
229	PCIE3_CLK_P	PCIe 3 Reference Clock+ (PCIe Ctrl #9)	Output	PCIe PHY
227	PCIE3_CLK_N	PCIe 3 Reference Clock- (PCIe Ctrl #9)	Output	PCIe PHY
223	PCIE3_RST*	PCIe 3 Reset (PCIe Ctrl #9). 4.7kΩ pull-up to 3.3V on the module.	Output	Open Drain 3.3V

Pin #	Signal Name	Description	Direction	Pin Type
225	PCIE3_CLKREQ*	PCIe 3 Clock Request (PCIe Ctrl #9). 47kΩ pull-up to 3.3V on the module.	Bidir	Open Drain 3.3V
179	PCIE_WAKE*	PCIe Wake. 47kΩ pull-up to 3.3V on the module.	Bidir	Open Drain 3.3V

See the *Jetson Orin NX Series Product Design Guide* for supported USB 3.2/PCIe configuration and connection examples.

2.11.3 Serial Peripheral Interface (SPI)

The Serial Peripheral Interface (SPI) controller allows a duplex, synchronous, serial communication between the controller and external peripheral devices; it supports both Master and Slave modes of operation on the SPI bus. See the *Jetson Orin NX Series Product Design Guide* for more information.

Features:

- > 2x SPI Interface
- > Master mode operation
 - All transfer modes (Mode 0, Mode 1, Mode 2, Mode 3) supported for both transmit and receive transactions.
- > FIFO Size: 64 x 32 bits
- > Programmable packet sizes of 4 to 32 bits.
- > Programmable clock phase and polarity.
- > Programmable delay between consecutive transfers.
- > Chip select controllable by software or generated by hardware on packet boundaries.

Table 2-13: SPI Mode Descriptions

SPI Mode	Clock Polarity	Clock Phase	SCK Inactive State	Data Latch In	Data Latch Out
0	0	0	Low	Latched IN on the positive edge of clock	Latched OUT on the negative edge of clock
1	0	1	Low	Latched IN on the negative edge of clock	Latched OUT on the positive edge of clock
2	1	0	High	Latched IN on the negative edge of clock	Latched OUT on the positive edge of clock
3	1	1	High	Latched IN on the positive edge of clock	Latched OUT on the negative edge of clock

Table 2-14: SPI Pin Descriptions

Pin #	Signal Name	Description	Direction	Pin Type
91	SPI0_SCK	SPI 0 Clock	Bidir	CMOS – 1.8V
89	SPI0_MOSI	SPI 0 Master Out / Slave In	Bidir	CMOS – 1.8V
93	SPI0_MISO	SPI 0 Master In / Slave Out	Bidir	CMOS – 1.8V

Pin #	Signal Name	Description	Direction	Pin Type
95	SPI0_CS0*	SPI 0 Chip Select 0	Bidir	CMOS – 1.8V
97	SPI0_CS1*	SPI 0 Chip Select 1	Bidir	CMOS – 1.8V
106	SPI1_SCK	SPI 1 Clock	Bidir	CMOS – 1.8V
104	SPI1_MOSI	SPI 1 Master Out / Slave In	Bidir	CMOS – 1.8V
108	SPI1_MISO	SPI 1 Master In / Slave Out	Bidir	CMOS – 1.8V
110	SPI1_CS0*	SPI 1 Chip Select 0	Bidir	CMOS – 1.8V
112	SPI1_CS1*	SPI 1 Chip Select 1	Bidir	CMOS – 1.8V

Figure 2-1: SPI Initiator Timing

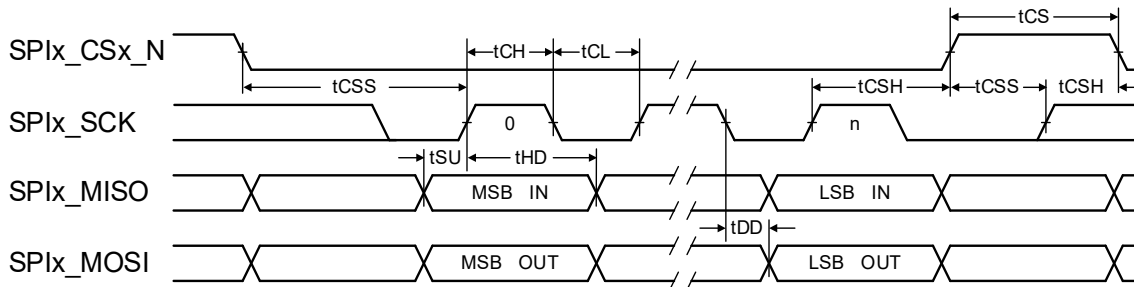

Table 2-15: SPI Initiator Timing Parameters

Symbol	Parameter	Min	Max	Unit
Fsck	SCK Clock Frequency		81.6	MHz
Fsck	SCK Clock Frequency (FSI SPI)		40	MHz
tSCP	SCK Period	1000 * 1/Fsck(max)	1000 * 1/Fsck(min)	ns
tCH	SCK high time	45% * tSCP	55% * tSCP	ns
tCL	SCK low time	45% * tSCP	55% * tSCP	ns
tCRT	SCK Rise time (slew rate)	0.1		V/ns
tCFT	SCK Fall time (slew rate)	0.1		V/ns
tSU	Data setup time (MISO)	2		ns
tHD	Data hold time (MISO)	3		ns
tDD	Active Clock edge to MOSI data Output Valid		6	ns
tCSS	CSx_N setup time	2		ns
tCSH	CSx_N hold time	3		ns
tCS	CSx_N high time	10		ns

Figure 2-2: SPI Target Timing

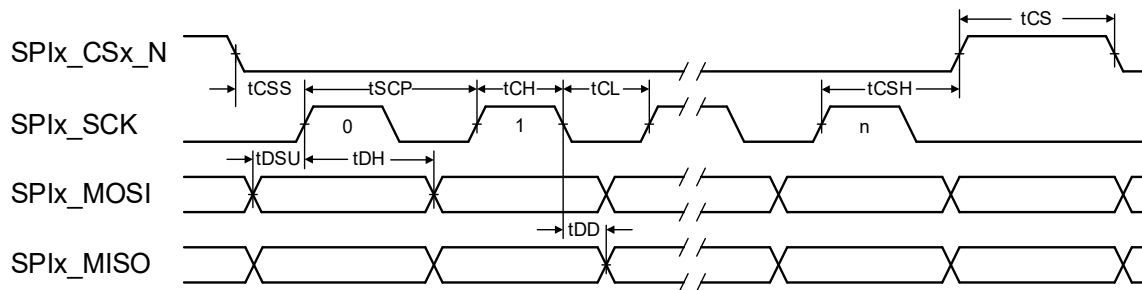

Table 2-16: SPI Target Timing Parameters

Symbol	Parameter	Min	Max	Unit
Fsck	SCK Clock Frequency		51	MHz
Fsck	SCK Clock Frequency (FSI SPI)		26	MHz
tSCP	SCK Period	20		ns
tCH	SCK high time	45% * tSCP	55% * tSCP	ns
tCL	SCK low time	45% * tSCP	55% * tSCP	ns
tCSS	CSx_N setup time	1 * tSCP		ns
tCSH	CSx_N hold time	1 * tSCP		ns
tCS	CSx_N high time	1 * tSCP		ns
tSU	Data setup time (MOSI)	4		ns
tHD	Data hold time (MOSI)	2		ns
tDD	Active Clock edge to MISO data Output Valid	2.5	17	ns
tHO	MISO Output Hold Time	2		ns

2.11.4 Universal Asynchronous Receiver/Transmitter (UART)

The UART controller provides serial data synchronization and data conversion (parallel-to-serial and serial-to-parallel) for both receiver and transmitter sections. Synchronization for serial data stream is accomplished by adding start and stop bits to the transmit data to form a data character. Data integrity is accomplished by attaching a parity bit to the data character. The parity bit can be checked by the receiver for any transmission bit errors.



Note: The UART receiver input has low baud rate tolerance in 1-stop bit mode. External devices must use two stop bits. In 1-stop bit mode, the UART receiver can lose sync between the receiver and the external transmitter resulting in data errors/corruption. In 2-stop bit mode, the extra stop bit allows the UART receiver logic to align properly with the UART transmitter.

Features:

- > 3x UART Interface
- > Synchronization for the serial data stream with start and stop bits to transmit data and form a data character.
- > Supports both 16450- and 16550-compatible modes. Default mode is 16450.
- > Device clock up to 68 MHz, baud rate of 4.25 Mbits/second.
- > Support for word lengths from five to eight bits, an optional parity bit and one or two stop bits.
- > Support for modem control inputs.
- > Auto sense baud detection.
- > Timeout interrupts to indicate if the incoming stream stopped.
- > Priority interrupts mechanism.
- > Flow control support on RTS and CTS.
- > SIR encoding/decoding (3/16 or 4/16 baud pulse widths to transmit bit zero).

Table 2-17: UART Pin Descriptions

Pin #	Signal Name	Description	Direction	Pin Type
99	UART0_TXD	UART #0 Transmit	Output	CMOS – 1.8V
101	UART0_RXD	UART #0 Receive	Input	CMOS – 1.8V
103	UART0_RTS*	UART #0 Request to Send	Output	CMOS – 1.8V
105	UART0_CTS*	UART #0 Clear to Send	Input	CMOS – 1.8V
203	UART1_TXD	UART #1 Transmit	Output	CMOS – 1.8V
205	UART1_RXD	UART #1 Receive	Input	CMOS – 1.8V
207	UART1_RTS*	UART #1 Request to Send	Output	CMOS – 1.8V
209	UART1_CTS*	UART #1 Clear to Send	Input	CMOS – 1.8V
236	UART2_TXD	UART #2 Transmit	Output	CMOS – 1.8V
238	UART2_RXD	UART #2 Receive	Input	CMOS – 1.8V

2.11.5 Controller Area Network (CAN)

Standard	Notes
ISO/DIS 16845-2	CAN conformance test
ISO 11898-1:2015	Data link layer and physical signaling; CAN FD Frame formats
ISO 11898-4:2004	Time-triggered communication

The Jetson Orin NX integrates the Bosch Time-Triggered Controller Area Network (M_TTCAN) controller version 3.2.0. Each independent CAN port/channel supports connectivity to one CAN network. Each port instantiates the Bosch M_TTCAN module, a message RAM module, an APB slave interface module, interrupt aggregator, time-triggered control module, and a wake detect module. All M_TTCAN external modules have direct connections to M_TTCAN except for the wake detect module.

Features:

- > Standard frame and extended frame transmission/reception enable.
- > Transfer rate: programmable bit rates up to 8 Mbps.
- > 0 – 8-byte data length, with the ability to receive the first 8 bytes when data length coding is > 8 Bytes.
- > 32 message buffers per channel.
- > Prioritization of transmit buffers.
- > Receive/transmit history list function.
- > Automatic block transmission function.
- > Multi-buffer receives block function.
- > Flexible maskable identifier filter support for two 32-bit, or four 16-bit, or eight 8-bit filters for each channel
- > Programmable data bit time, communication baud rate, and sample point.
 - As an example, the following sample-point configurations can be configured: 66.7%, 70.0%, 75.0%, 80.0%, 81.3%, 85.0%, and 87.5%
 - Baud rates in the range of 10 kbps up to 1000 kbps can be configured.
- > Enhanced features:
 - Each message buffer can be configured to operate as a transmit or a receive message buffer.
 - Transmission priority is controlled by the identifier or by mailbox number (selectable).
 - A transmission request can be aborted by clearing the dedicated Transmit-Request flag of the concerned message buffer.
 - Automatic block transmission (ABT) operation mode.
 - Time stamp function for CAN channels 0 to n in collaboration with timers.
- > Release from bus-off state by software.
- > Wake-up with integrated low-pass filter (debounce) option to prevent short glitches on CAN bus, through CAN receive signal toggling from CAN transceiver.
 - For normal operation (after wake) there is a digital filter in the CAN controller.
- > Listen-only mode to monitor CAN bus.
- > Wake-up signal to both internal and external (either interrupt signal or GPIO) to initiate power up if needed.
 - Ready to receive the first CAN message within 10ms of wake event generated by the CAN master.
 - Ready to transmit the first CAN message within 50ms of wake event generated by the CAN master.
- > Loop back for self-test.

Table 2-18: CAN Pin Descriptions

Pin #	Signal Name	Description	Direction	Pin Type
145	CAN_TX	CAN Transmit	Output	CMOS – 3.3V
143	CAN_RX	CAN Receive	Input	CMOS – 3.3V

2.11.6 Inter-Chip Communication (I2C)

Standard	Notes
NXP inter-IC-bus (I2C) specification	https://i2c.info/i2c-bus-specification

This general purpose I2C controller allows system expansion for I2C-based devices as defined in the NXP inter-IC-bus (I2C) specification. The I2C bus supports serial device communications to multiple devices. (4x I2C) The I2C controller handles clock source negotiation, speed negotiation for standard and fast devices, 7-bit slave address support according to the I2C protocol and supports master and slave modes of operation.

The I2C controller supports the following operating modes:

- > Master – Standard-mode (up to 100 Kbit/s), Fast-mode (up to 400 Kbit/s), Fast-mode plus (Fm+, up to 1 Mbit/s).
- > Slave – Standard-mode (up to 100 Kbit/s), Fast-mode (up to 400 Kbit/s), Fast-mode plus (Fm+, up to 1 Mbit/s).

Table 2-19: I2C Pin Descriptions

Pin #	Signal Name	Description	Direction	Pin Type
185	I2C0_SCL	General I2C 0 Clock. 1.5kΩ pull-up to 3.3V on module.	Bidir	Open Drain – 3.3V
187	I2C0_SDA	General I2C 0 Data. 1.5kΩ pull-up to 3.3V on the module.	Bidir	Open Drain – 3.3V
189	I2C1_SCL	General I2C 1 Clock. 2.2kΩ pull-up to 3.3V on the module.	Bidir	Open Drain – 3.3V
191	I2C1_SDA	General I2C 1 Data. 2.2kΩ pull-up to 3.3V on the module.	Bidir	Open Drain – 3.3V
232	I2C2_SCL	General I2C 2 Clock. 2.2kΩ pull-up to 1.8V on the module.	Bidir	Open Drain – 1.8V
234	I2C2_SDA	General I2C 2 Data. 2.2kΩ pull-up to 1.8V on the module.	Bidir	Open Drain – 1.8V
213	CAM_I2C_SCL	Camera I2C Clock. 2.2kΩ pull-up to 3.3V on the module.	Bidir	Open Drain – 3.3V
215	CAM_I2C_SDA	Camera I2C Data. 2.2kΩ pull-up to 3.3V on the module.	Bidir	Open Drain – 3.3V

2.11.7 Inter-IC Sound (I2S)

Standard
Inter-IC Sound (I2S) specification

The I2S controller transports streaming audio data between system memory and an audio codec. The I2S controller supports I2S format, left-justified mode format, right-justified mode format, and DSP mode format, as defined in the Philips inter-IC-sound (I2S) bus specification.

The I2S and PCM (master and slave modes) interfaces support clock rates up to 24.5760 MHz.

The I2S controller supports point-to-point serial interfaces for the I2S digital audio streams. I2S-compatible products, such as compact disc players, digital audio tape devices, digital sound processors, and those with digital TV sound may be directly connected to the I2S controller.

The controller also supports the PCM and telephony mode of data-transfer. Pulse-Code-Modulation (PCM) is a standard method used to digitize audio (particularly voice) patterns for transmission over digital communication channels. The Telephony mode is used to transmit and receive data to and from an external mono CODEC in a slot-based scheme of time-division multiplexing (TDM). The I2S controller supports Bidirectional audio streams and can operate in half-duplex or full-duplex mode.

Features:

- > Basic I2S modes to be supported (I2S, RJM, LJM, and DSP) in both master and slave modes.
- > PCM mode with short (one bit-clock wide) and long-fsync (two bit-clock wide) in both master and slave modes.
- > NW-mode with independent slot-selection for both transmit and receive.
- > TDM mode with flexibility in number of slots and slot(s) selection.
- > Capability to drive-out a high-z outside the prescribed slot for transmission.
- > Flow control for the external input/output stream.

Table 2-20: I2S Pin Descriptions

Pin #	Signal Name	Description	Direction	Pin Type
199	I2S0_SCLK	I2S Audio Port 0 Clock	Bidir	CMOS – 1.8V
197	I2S0_FS	I2S Audio Port 0 Left/Right Clock	Bidir	CMOS – 1.8V
193	I2S0_DOUT	I2S Audio Port 0 Data Out	Output	CMOS – 1.8V
195	I2S0_DIN	I2S Audio Port 0 Data In	Input	CMOS – 1.8V
226	I2S1_SCLK	I2S Audio Port 1 Clock	Bidir	CMOS – 1.8V
224	I2S1_FS	I2S Audio Port 1 Left/Right Clock	Bidir	CMOS – 1.8V
220	I2S1_DOUT	I2S Audio Port 1 Data Out	Output	CMOS – 1.8V
222	I2S1_DIN	I2S Audio Port 1 Data In	Input	CMOS – 1.8V

2.11.8 Gigabit Ethernet

Standard	Notes
Gigabit Ethernet (GbE)	IEEE 802.3ab

The on-module Ethernet controller supports:

- > 10/100/1000 Gigabit Ethernet
- > IEEE 802.3u Media Access Controller (MAC)

Table 2-21: Gigabit Ethernet Pin Descriptions

Pin #	Signal Name	Description	Direction	Pin Type
184	GBE_MDI0_N	GbE Transformer Data 0-	Bidir	MDI
186	GBE_MDI0_P	GbE Transformer Data 0+	Bidir	MDI
190	GBE_MDI1_N	GbE Transformer Data 1-	Bidir	MDI
192	GBE_MDI1_P	GbE Transformer Data 1+	Bidir	MDI
196	GBE_MDI2_N	GbE Transformer Data 2-	Bidir	MDI
198	GBE_MDI2_P	GbE Transformer Data 2+	Bidir	MDI
202	GBE_MDI3_N	GbE Transformer Data 3-	Bidir	MDI
204	GBE_MDI3_P	GbE Transformer Data 3+	Bidir	MDI
188	GBE_LED_LINK	Ethernet Link LED (Green)	Output	-
194	GBE_LED_ACT	Ethernet Activity LED (Yellow)	Output	-

2.11.9 Fan

The Jetson Orin NX includes a Pulse Width Modulator (PWM) and Tachometer functionality to enable fan control as part of a thermal solution. The PWM controller is a frequency divider with a varying pulse width. The PWM runs off a device clock programmed in the Clock and Reset controller and can be any frequency up to the device clock maximum speed of 48 MHz. The PWM gets divided by 256 before being subdivided based on a programmable value.

2.11.10 Pulse Width Modulator (PWM)

The Jetson Orin NX has four PWM outputs. Each PWM output is based on a frequency divider whose pulse width varies. Each has a programmable frequency divider and a programmable pulse width generator. The PWM controller supports one PWM output for each of its four instances. Each instance is allocated a 64 KB independent address space.

Frequency division is a 13-bit programmable value, and pulse division is an 8-bit value. The PWM can run at a maximum frequency of up to 408 MHz. The PWM controller can source its clock from either CLK_M or PLLP. CLK_M (19.2 MHz) is derived from the OSC clock (38.4 MHz). PLLP operates at 408 MHz.

The PWM clock frequency is divided by 256 before subdividing it based on the programmable frequency division value to generate the required frequency for the PWM output. The maximum

output frequency that can be achieved from this configuration is $408 \text{ MHz}/256 = 1.6 \text{ MHz}$. This 1.6 MHz frequency can be further divided using the frequency divisor in PWM.

The OSC clock is the primary/default source for the PWM IP clock. For higher PWM output frequency requirements, PLLP is the clock source (up to 408 MHz).

Table 2-22: PWM Pin Descriptions

Pin #	Signal Name	Description	Direction	Pin Type
206	GPIO07	Pulse Width Modulator or GPIO #7	Bidir	CMOS - 1.8V
218	GPIO12	Pulse Width Modulator or GPIO #12	Bidir	CMOS - 1.8V
228	GPIO13	Pulse Width Modulator or GPIO #13	Bidir	CMOS - 1.8V
230	GPIO14	Pulse Width Modulator or GPIO #14	Bidir	CMOS - 1.8V

2.12 Deep Learning Accelerator (DLA)

The DLA is a fixed function engine used to accelerate inference operations on convolutional neural networks (CNNs). Jetson Orin NX implements the second generation of NVIDIA's DLA architecture. The DLA supports accelerating CNN layers such as convolution, deconvolution, activation, pooling, local response normalization, and fully connected layers.

Specific optimizations include:

- > Structured Sparsity.
- > Depth-wise Convolution capability.
- > A dedicated Hardware Scheduler to maximize efficiency.

DLA hardware is comprised of the following components:

1. Convolution Core – optimized high-performance convolution engine.
Convolution operations work on two sets of data: one set of offline-trained “weights” (which remain constant between each run of inference), and one set of input “feature” data (which varies with the network’s input). The convolutional engine exposes parameters to map many varied sizes of convolutions onto the hardware with high efficiency.
2. Single Data Point Processor – single-point lookup engine for activation functions.
The Single Data Point Processor (SDP) allows for the application of both linear and non-linear functions onto individual data points. This is commonly used immediately after convolution in CNN systems. The SDP has a lookup table to implement non-linear functions, or for linear functions it supports simple bias and scaling. This combination can support most common activation functions, as well as other element-wise operations, including ReLU, PReLU, precision scaling, batch normalization, bias addition, or other complex non-linear functions, such as a sigmoid or a hyperbolic tangent.
3. Planar Data Processor – planar averaging engine for pooling.
The Planar Data Processor (PDP) supports specific spatial operations that are common in CNN applications. It is configurable at runtime to support different pool group sizes, and supports three pooling functions: maximum-pooling, minimum-pooling, and average-pooling.
4. Cross-Channel Data Processor – multi-channel averaging engine for advanced normalization functions.
The Cross-channel Data Processor (CDP) is a specialized unit built to apply the local response

normalization (LRN) function – a special normalization function that operates on channel dimensions, as opposed to the spatial dimensions.

5. Data Reshape Engines – memory-to-memory transformation acceleration for tensor reshape and copy operations. The data reshape engine performs data format transformations (e.g., splitting or slicing, merging, contraction, reshape-transpose). Data in memory often needs to be reconfigured or reshaped in the process of performing inferencing on a convolutional network. For example, slice operations may be used to separate out distinctive features or spatial regions of an image, while reshape-transpose operations (common in deconvolutional networks) create output data with larger dimensions than the input dataset.
6. Bridge DMA – accelerated path to move data between two non-connected memory systems. The bridge DMA (BDMA) module provides a data copy engine to move data between the system DRAM and the dedicated memory interface.

2.13 Programmable Vision Accelerator (PVA)

The Programmable Vision Accelerator (PVA) V.2 is an application-specific instruction vector processor that implements some of the common filter loops and other common computer vision algorithms such as Harris corners, stereo disparity, and more. Each PVA cluster consists of a Cortex-R5 core along with two dedicated vector processing units, each with its own memory and DMA. The PVA can be programmed to perform several pre-defined functions using the NVIDIA Vision Programming Interface (VPI) software library.

Chapter 3. Power and System Management

See the *Jetson Orin NX Series Product Design Guide* for details on connecting to each of the interfaces.

Table 3-1: Power and System Control Pin Descriptions

Pin #	Signal Name	Description	Direction	Pin Type
251 252 253 254 255 256 257 258 259 260	VDD_IN	Main power – Supplies PMIC and other registers. MAXN_SUPER at 40W for Jetson Orin NX requires minimum 8.0V to the VDD_IN.	Input	5V to 20V
235	PMIC_BBAT	Real Time Clock. Optionally used to provide back-up power for the RTC in the Power Sequencer. Connects to a Lithium Cell or similar power source. The cell sources power for the RTC when system is disconnected from power.	Input	1.85V to 5.5V
214	FORCE_RECOVERY*	Force Recovery strap pin. Held low when SYS_RESET* goes high (i.e., during power-on) places system in USB recovery mode. 10kΩ pull-up to 1.8V on the module.	Input	CMOS – 1.8V
240	SLEEP/WAKE*	Configured as GPIO for optional use to indicate the system should enter or exit sleep mode.	Input	CMOS – 5.0V
233	SHUTDOWN_REQ*	When driven/pulled low by the module, requests the carrier board to shut down. ~5kΩ pull-up to VDD_IN on the module.	Output	Open Drain, VDD_IN
237	POWER_EN	Signal for module on/off: high level on, low level off. Connects to module Power Sequencer/PMIC ENO through converter logic. POWER_EN is routed to a Schmitt trigger buffer on the module. A 100kΩ pulldown is also on the module.	Input	Analog 5.0V
239	SYS_RESET*	Module Reset. Reset to the module when driven low by the carrier board. Used as carrier board supply enable when driven high by the module when module power sequence is complete. Used to ensure proper power	Bidir	Open Drain, 1.8V

Pin #	Signal Name	Description	Direction	Pin Type
		on/off sequencing between module and carrier board supplies. 10kΩ pull-up to VDD_1V8 on the module.		
178	MOD_SLEEP*	Module Sleep. When active (low), indicates module has gone to Sleep (SC7) mode.	Output	CMOS – 1.8V
210	CLK_32K_OUT	Sleep/Suspend clock. 2.2kΩ pull-up to VDD_1V8 on the module. If used on the carrier board, a buffer should be implemented close to the module pin. If not used, leave NC.	Output	CMOS – 1.8V
217	MODULE_ID	When tied to GND, the module is a legacy type supporting only 5V on VDD_IN. When floating, the module is an advanced type supporting 5V to 20V on VDD_IN.	-	Strap

3.1 Power Rails

VDD_IN must be supplied by the carrier board that the Jetson Orin NX is designed to connect to. All Jetson Orin NX interfaces are referenced to on-module voltage rails and no I/O voltage is required to be supplied to the module. See the *Jetson Orin NX Series Product Design Guide* for details of connecting to each of the interfaces.

3.2 Power Domains/Islands

Jetson Orin NX has a single three-channel INA that can measure power of CPU_GPU_CV combined rail, Core, and module input power.

3.3 Power Management Controller (PMC)

The PMC power management features enable both high speed operation and very low-power standby states. The PMC primarily controls voltage transitions for the SoC as it transitions to/from different low power modes; it also acts as a target receiving dedicated power/clock request signals as well as wake events from various sources (e.g., SPI, I2C, RTC, USB) which can wake the system from deep sleep state. The PMC enables aggressive power-gating capabilities on idle modules and integrates specific logic to maintain defined states and control power domains during sleep and deep sleep modes.

3.4 Resets

If reset is asserted, the Jetson Orin NX SoC and onboard storage will be reset. This signal is also used for baseboard power sequencing.

3.5 PMIC_BBAT

An optional back up battery can be attached to the PMIC_BBAT module input to maintain the module real-time clock (RTC) when VIN is not present. Batteries can be used to power the pin, but charging is not supported. This pin is connected directly to the onboard PMIC. RTC accuracy is -11 ~ +20 seconds/day.

Table 3-2: PMIC_BBAT Pin Descriptions

Pin #	Signal Name	Description	Direction	Pin Type
235	PMIC_BBAT	Real Time Clock. Optionally used to provide back-up power for the RTC in the Power Sequencer. Connects to a Lithium Cell or similar power source. The cell sources power for the RTC when system is disconnected from power. Power consumption on battery backup operation is 12 to 50 μ A.	Input	1.85V to 5.5V

3.6 Power Sequencing

The Jetson Orin NX is required to be powered on and off in a known sequence. Sequencing is determined through a set of control signals; the SYS_RESET* signal (when deasserted) is used to indicate when the carrier board can power on. The following sections provide an overview of the power sequencing steps between the carrier board and Jetson Orin NX. Refer to the *Jetson Orin NX Series Product Design Guide* for system level details on the application of power, power sequencing, and monitoring. The Jetson Orin NX and the product carrier board must be power sequenced properly to avoid potential damage to components on either the module or the carrier board system.

3.6.1 Power Up

During power up, the carrier board must wait until the signal SYS_RESET* is deasserted from the Jetson module before enabling its power; the Jetson module deasserts the SYS_RESET* signal to enable the complete system to boot.



Note: I/O pins cannot be high (>0.5V) before SYS_RESET* goes high. When SYS_RESET* is low, the maximum voltage applied to any I/O pin is 0.5V.

3.6.2 Power Down

Shutdown events can be triggered by either the module or the baseboard, but the shutdown event will always be serviced by the baseboard. To do so, the baseboard deasserts POWER_EN, which begins the shutdown power sequence on the module. If the module needs to request a shutdown event in the case of thermal, software, or under-voltage events, it will assert SHUTDOWN_REQ*. When the baseboard sees low SHUTDOWN_REQ*, it should deassert POWER_EN as soon as possible.

Once POWER_EN is deasserted, the module asserts SYS_RESET*, and the baseboard may shut down. SoC 3.3V I/O must reach 0.5V or lower at most 1.5ms after SYS_RESET* is asserted. SoC 1.8V I/O must reach 0.5V or lower at most 4ms after SYS_RESET* is asserted.

3.7 Power States

The Jetson Orin NX operates in three main power modes: OFF, ON, and SLEEP. The module transitions between these states are based on various events from hardware or software. The figure below shows the transitions between these three states.

Figure 3-1: Power State Transition Diagram

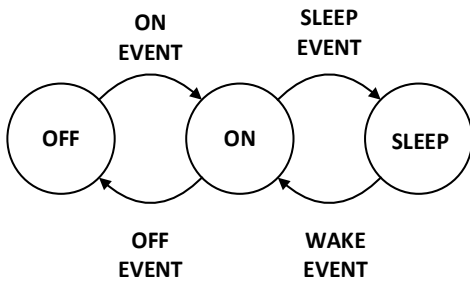

3.7.1 ON State

The ON power state is entered from either OFF or SLEEP states. In this state, the Jetson Orin NX module is fully functional and operates normally. An ON event must occur for a transition between OFF and ON states. The only ON EVENT currently used is a low to high transition on the POWER_EN pin. This must occur with VDD_IN connected to a power rail and POWER_EN is asserted (at a logic 1). The POWER_EN control is the carrier board indication to the Jetson module that the VDD_IN power is good. The carrier board should assert this high only when VDD_IN has reached its required voltage level and is stable. This prevents the Jetson Orin NX Module from powering up until the VDD_IN power is stable.

3.7.2 OFF State

The OFF state is the default state when the system is not powered. It can only be entered from the ON state, through an OFF event. OFF events are listed in the table below.

Table 3-3: OFF State Events

Event	Details	Preconditions
HW Shutdown	Set POWER_EN pin to zero for at least 10 μ s, the internal PMIC starts the shutdown sequence.	In ON State
SW Shutdown	Software initiated shutdown	ON state, software operational

Event	Details	Preconditions
Thermal Shutdown	If the internal temperature of the Jetson Orin NX module reaches an unsafe temperature, the hardware is designed to initiate a shutdown.	Any power state



Note: HW shutdown, SW shutdown, and Thermal shutdown all assert SHUTDOWN_REQ* low. System on Module does not initiate power supply shutdown sequence until POWER_EN is deasserted.

3.7.3 SLEEP State

The SLEEP state can only be entered from the ON state. This state allows the module to quickly resume to an operational state without performing a full boot sequence. The SLEEP state also includes a low power mode SC7 (deep sleep) where the module operates only with enough circuitry powered to allow the device to resume and re-enter the ON state. During this state the output signals from the module are maintained at their logic level prior to entering the state (i.e., they do not change to a 0V level). To exit the SLEEP state a WAKE event must occur; WAKE events can occur from within the module or from external devices through various pins on the module connector.

Table 3-4: SLEEP and WAKE Events

Event	Details
Thermal Condition	If the module internal temperature exceeds programmed hot and cold limits the system is forced to wake up, so it can report and take appropriate action (shut down for example).
USB VBUS detection	If VBUS is applied to the system (USB cable attached) then the device can be configured to Wake and enumerate.
Module connector Interface WAKE signals	Programmable signals on the module connector.

3.8 Thermal and Power Monitoring

The Jetson Orin NX is designed to operate under various workloads and environmental conditions. It has been designed so that an active or passive heat sink solution can be attached. The module contains various methods through hardware and software to limit the internal temperature to within operating limits. See the Jetson Orin NX Series Thermal Design Guide for more details.

Chapter 4. Pin Definitions

The function(s) for each pin on the module is fixed to a single Special-Function I/O (SFIO) or software-controlled General Purpose I/O (GPIO). The Jetson Orin NX has multiple dedicated GPIOs, and each GPIO is individually configurable as Output/Input/Interrupt sources with level/edge controls. SFIO and GPIO functionality is configured using Multi-Purpose I/O (MPIO) pads with each MPIO pad consisting of:

- > An output driver with tristate capability, drive strength controls and push-pull mode, open-drain mode, or both.
- > An input receiver with either Schmitt mode, CMOS mode, or both.
- > A weak pull-up and a weak pull-down.

MPIO pads are partitioned into multiple pad control groups with controls being configured for the group. During normal operation, these per-pad controls are driven by the pinmux controller registers. During deep sleep, the PMC bypasses and then resets the pinmux controller registers. Software reprograms these registers as necessary after returning from deep sleep.

Refer to the *Jetson Orin NX Series Product Design Guide* and the *Pinmux Spreadsheet* for more information.

4.1 Power-on Reset Behavior

Each MPIO pad has a deterministic power-on reset (PoR) state. The reset state for each pad is chosen to minimize the need of additional on-board components; for example, on-chip weak pull-ups are enabled during PoR for pads which are usually used to drive active-low chip selects eliminating the need for additional pull-up resistors.

The following list is a simplified description of the Jetson Orin NX boot process focusing on those aspects which relate to the MPIO pins:

- > System-level hardware executes the power-up sequence. This sequence ends when system-level hardware releases SYS_RESET_N.
- > The Boot ROM begins executing and programs the on-chip I/O controllers to access the secondary boot device (QSPI).
- > The Boot ROM fetches the Boot Configuration Table (BCT) and boot loader from the secondary boot device.
- > If the BCT and boot loader are fetched successfully, the Boot ROM transfers control to the boot loader.
- > Otherwise, the Boot ROM enters USB recovery mode.

4.2 Sleep Behavior

Sleep is an ultra-low-power standby state in which the module maintains much of its I/O state while most of the chip is powered off. During deep sleep most of the pads are put in a state called Deep Power Down (DPD). The sequence for entering DPD is same across pads.

MPIO pads can vary during deep sleep. They differ regarding:

- > Input buffer behavior during deep sleep
 - Forcibly disabled OR
 - Enabled for use as a GPIO wake event, OR
 - Enabled for some other purpose (e.g., a clock request pin)
- > Output buffer behavior during deep sleep
 - Maintain a static programmable (0, 1, or tristate) constant value OR
 - Capable of changing state (i.e., dynamic while the chip is still in deep sleep)
- > Weak pull-up/pull-down behavior during deep sleep
 - Forcibly disabled OR
 - Can be configured
- > Pads that do not enter deep sleep
 - Some of the pads whose outputs are dynamic during deep sleep are of special type and they do not enter deep sleep.

4.3 GPIO

The Jetson Orin NX has multiple dedicated GPIOs. Each GPIO can be individually configurable as an Output, Input, or Interrupt source with level/edge controls. The pins listed in the following table are dedicated GPIOs; some with alternate SFIO functionality. Many other pins not included in this list are capable of being configured as GPIOs instead of the SFIO functionality the pin name suggests (e.g., UART, SPI, I2S, etc.). All pins that can support GPIO functionality have this exposed in the Pinmux.

Table 4-1: GPIO Pin Descriptions

Pin #	Signal Name	Description	Direction	Pin Type
87	GPIO00	GPIO #0 or USB 0 VBUS Enable #0	Bidir	CMOS – 1.8V
118	GPIO01	GPIO #1 or Generic Clock	Bidir	CMOS – 1.8V
124	GPIO02	GPIO #2	Bidir	CMOS – 1.8V
126	GPIO03	GPIO #3	Bidir	CMOS – 1.8V
127	GPIO04	GPIO #4	Bidir	CMOS – 1.8V
128	GPIO05	GPIO #5	Bidir	CMOS – 1.8V
130	GPIO06	GPIO #6	Bidir	CMOS – 1.8V
206	GPIO07	GPIO #7 or Pulse Width Modulator	Bidir	CMOS – 1.8V
208	GPIO08	GPIO #8 or Fan Tachometer	Bidir	CMOS – 1.8V
211	GPIO09	GPIO #9 or Audio Codec Master Clock	Bidir	CMOS – 1.8V

Pin #	Signal Name	Description	Direction	Pin Type
212	GPIO10	GPIO #10	Bidir	CMOS – 1.8V
216	GPIO11	GPIO #11 or Generic Clock	Bidir	CMOS – 1.8V
218	GPIO12	GPIO #12 or Pulse Width Modulator	Bidir	CMOS – 1.8V
228	GPIO13	GPIO #13 or Pulse Width Modulator	Bidir	CMOS – 1.8V
230	GPIO14	GPIO #14 or Pulse Width Modulator	Bidir	CMOS – 1.8V

4.4 Pin List



Note: For cell shading, light green indicates ground; light blue indicates Jetson Orin NX specific functionality.

Jetson SODIMM Signal Name	Jetson Orin NX Function	Pin # Top Odd	Pin # Bottom Even	Jetson SODIMM Signal Name	Jetson Orin NX Function
GND	GND	1	2	GND	GND
CSI1_DO_N	CSI1_DO_N	3	4	CSI0_DO_N	CSI0_DO_N
CSI1_DO_P	CSI1_DO_P	5	6	CSI0_DO_P	CSI0_DO_P
GND	GND	7	8	GND	GND
CSI1_CLK_N	CSI1_CLK_N	9	10	CSI0_CLK_N	CSI0_CLK_N
CSI1_CLK_P	CSI1_CLK_P	11	12	CSI0_CLK_P	CSI0_CLK_P
GND	GND	13	14	GND	GND
CSI1_D1_N	CSI1_D1_N	15	16	CSI0_D1_N	CSI0_D1_N
CSI1_D1_P	CSI1_D1_P	17	18	CSI0_D1_P	CSI0_D1_P
GND	GND	19	20	GND	GND
CSI3_DO_N	CSI3_DO_N	21	22	CSI2_DO_N	CSI2_DO_N
CSI3_DO_P	CSI3_DO_P	23	24	CSI2_DO_P	CSI2_DO_P
GND	GND	25	26	GND	GND
CSI3_CLK_N	CSI3_CLK_N	27	28	CSI2_CLK_N	CSI2_CLK_N
CSI3_CLK_P	CSI3_CLK_P	29	30	CSI2_CLK_P	CSI2_CLK_P
GND	GND	31	32	GND	GND
CSI3_D1_N	CSI3_D1_N	33	34	CSI2_D1_N	CSI2_D1_N
CSI3_D1_P	CSI3_D1_P	35	36	CSI2_D1_P	CSI2_D1_P
GND	GND	37	38	GND	GND
DPO_TXD0_N	USBSS1_RX_N	39	40	CSI4_D2_N	PCIE2_RX0_N
DPO_TXD0_P	USBSS1_RX_P	41	42	CSI4_D2_P	PCIE2_RX0_P
GND	GND	43	44	GND	GND
DPO_TXD1_N	USBSS1_TX_N	45	46	CSI4_D0_N	PCIE2_TX0_N
DPO_TXD1_P	USBSS1_TX_P	47	48	CSI4_D0_P	PCIE2_TX0_P
GND	GND	49	50	GND	GND

Jetson SODIMM Signal Name	Jetson Orin NX Function	Pin # Top Odd	Pin # Bottom Even	Jetson SODIMM Signal Name	Jetson Orin NX Function
DPO_TXD2_N	USBSS2_RX_N	51	52	CSI4_CLK_N	PCIE2_CLK_N
DPO_TXD2_P	USBSS2_RX_P	53	54	CSI4_CLK_P	PCIE2_CLK_P
GND	GND	55	56	GND	GND
DPO_TXD3_N	USBSS2_TX_N	57	58	CSI4_D1_N	PCIE2_RX1_N (PCIE3_RX0_N)
DPO_TXD3_P	USBSS2_TX_P	59	60	CSI4_D1_P	PCIE2_RX1_P (PCIE3_RX0_P)
GND	GND	61	62	GND	GND
DP1_TXD0_N	DP1_TXD0_N	63	64	CSI4_D3_N	PCIE2_TX1_N (PCIE3_TX0_N)
DP1_TXD0_P	DP1_TXD0_P	65	66	CSI4_D3_P	PCIE2_TX1_P (PCIE3_TX0_P)
GND	GND	67	68	GND	GND
DP1_TXD1_N	DP1_TXD1_N	69	70	DSI_D0_N	RSVD
DP1_TXD1_P	DP1_TXD1_P	71	72	DSI_D0_P	RSVD
GND	GND	73	74	GND	GND
DP1_TXD2_N	DP1_TXD2_N	75	76	DSI_CLK_N	RSVD
DP1_TXD2_P	DP1_TXD2_P	77	78	DSI_CLK_P	RSVD
GND	GND	79	80	GND	GND
DP1_TXD3_N	DP1_TXD3_N	81	82	DSI_D1_N	RSVD
DP1_TXD3_P	DP1_TXD3_P	83	84	DSI_D1_P	RSVD
GND	GND	85	86	GND	GND
GPIO00	GPIO00	87	88	DPO_HPD	RSVD
SPI0_MOSI	SPI0_MOSI	89	90	DPO_AUX_N	RSVD
SPI0_SCK	SPI0_SCK	91	92	DPO_AUX_P	RSVD
SPI0_MISO	SPI0_MISO	93	94	HDMI_CEC	HDMI_CEC
SPI0_CS0*	SPI0_CS0*	95	96	DP1_HPD	DP1_HPD
SPI0_CS1*	SPI0_CS1*	97	98	DP1_AUX_N	DP1_AUX_N
UART0_TXD	UART0_TXD	99	100	DP1_AUX_P	DP1_AUX_P
UART0_RXD	UART0_RXD	101	102	GND	GND
UART0_RTS*	UART0_RTS*	103	104	SPI1_MOSI	SPI1_MOSI
UART0_CTS*	UART0_CTS*	105	106	SPI1_SCK	SPI1_SCK
GND	GND	107	108	SPI1_MISO	SPI1_MISO
USB0_D_N	USB0_D_N	109	110	SPI1_CS0*	SPI1_CS0*
USB0_D_P	USB0_D_P	111	112	SPI1_CS1*	SPI1_CS1*
GND	GND	113	114	CAM0_PWDN	CAM0_PWDN
USB1_D_N	USB1_D_N	115	116	CAM0_MCLK	CAM0_MCLK
USB1_D_P	USB1_D_P	117	118	GPIO01	GPIO01 (CLK)
GND	GND	119	120	CAM1_PWDN	CAM1_PWDN

Jetson SODIMM Signal Name	Jetson Orin NX Function	Pin # Top Odd	Pin # Bottom Even	Jetson SODIMM Signal Name	Jetson Orin NX Function
USB2_D_N	USB2_D_N	121	122	CAM1_MCLK	CAM1_MCLK
USB2_D_P	USB2_D_P	123	124	GPIO02	GPIO02
GND	GND	125	126	GPIO03	GPIO03
GPIO04	GPIO04	127	128	GPIO05	GPIO05
GND	GND	129	130	GPIO06	GPIO06
PCIE0_RX0_N	PCIE0_RX0_N	131	132	GND	GND
PCIE0_RX0_P	PCIE0_RX0_P	133	134	PCIE0_TX0_N	PCIE0_TX0_N
GND	GND	135	136	PCIE0_TX0_P	PCIE0_TX0_P
PCIE0_RX1_N	PCIE0_RX1_N	137	138	GND	GND
PCIE0_RX1_P	PCIE0_RX1_P	139	140	PCIE0_TX1_N	PCIE0_TX1_N
GND	GND	141	142	PCIE0_TX1_P	PCIE0_TX1_P
CAN_RX	CAN_RX	143	144	GND	GND
CAN_TX	CAN_TX	145	146	GND	GND
GND	GND	147	148	PCIE0_TX2_N	PCIE0_TX2_N
PCIE0_RX2_N	PCIE0_RX2_N	149	150	PCIE0_TX2_P	PCIE0_TX2_P
PCIE0_RX2_P	PCIE0_RX2_P	151	152	GND	GND
GND	GND	153	154	PCIE0_TX3_N	PCIE0_TX3_N
PCIE0_RX3_N	PCIE0_RX3_N	155	156	PCIE0_TX3_P	PCIE0_TX3_P
PCIE0_RX3_P	PCIE0_RX3_P	157	158	GND	GND
GND	GND	159	160	PCIE0_CLK_N	PCIE0_CLK_N
USBSS_RX_N	USBSS0_RX_N	161	162	PCIE0_CLK_P	PCIE0_CLK_P
USBSS_RX_P	USBSS0_RX_P	163	164	GND	GND
GND	GND	165	166	USBSS_TX_N	USBSS0_TX_N
PCIE1_RX0_N	PCIE1_RX0_N	167	168	USBSS_TX_P	USBSS0_TX_P
PCIE1_RX0_P	PCIE1_RX0_P	169	170	GND	GND
GND	GND	171	172	PCIE1_TX0_N	PCIE1_TX0_N
PCIE1_CLK_N	PCIE1_CLK_N	173	174	PCIE1_TX0_P	PCIE1_TX0_P
PCIE1_CLK_P	PCIE1_CLK_P	175	176	GND	GND
GND	GND	177	178	MOD_SLEEP*	MOD_SLEEP*
PCIE_WAKE*	PCIE_WAKE*	179	180	PCIE0_CLKREQ*	PCIE0_CLKREQ*
PCIE0_RST*	PCIE0_RST*	181	182	PCIE1_CLKREQ*	PCIE1_CLKREQ*
PCIE1_RST*	PCIE1_RST*	183	184	GBE_MDIO_N	GBE_MDIO_N
I2C0_SCL	I2C0_SCL	185	186	GBE_MDIO_P	GBE_MDIO_P
I2C0_SDA	I2C0_SDA	187	188	GBE_LED_LINK	GBE_LED_LINK
I2C1_SCL	I2C1_SCL	189	190	GBE_MDII_N	GBE_MDII_N
I2C1_SDA	I2C1_SDA	191	192	GBE_MDII_P	GBE_MDII_P
I2S0_DOUT	I2S0_DOUT	193	194	GBE_LED_ACT	GBE_LED_ACT
I2S0_DIN	I2S0_DIN	195	196	GBE_MDI2_N	GBE_MDI2_N

Jetson SODIMM Signal Name	Jetson Orin NX Function	Pin # Top Odd	Pin # Bottom Even	Jetson SODIMM Signal Name	Jetson Orin NX Function
I2S0_FS	I2S0_FS	197	198	GBE_MDI2_P	GBE_MDI2_P
I2S0_SCLK	I2S0_SCLK	199	200	GND	GND
GND	GND	201	202	GBE_MDI3_N	GBE_MDI3_N
UART1_TXD	UART1_TXD	203	204	GBE_MDI3_P	GBE_MDI3_P
UART1_RXD	UART1_RXD	205	206	GPIO07	GPIO07
UART1_RTS*	UART1_RTS*	207	208	GPIO08	GPIO08
UART1_CTS*	UART1_CTS*	209	210	CLK_32K_OUT	CLK_32K_OUT
GPIO09	GPIO09	211	212	GPIO10	GPIO10
CAM_I2C_SCL	CAM_I2C_SCL	213	214	FORCE_RECOVERY*	FORCE_RECOVERY*
CAM_I2C_SDA	CAM_I2C_SDA	215	216	GPIO11	GPIO11
GND	MODULE_ID	217	218	GPIO12	GPIO12
SDMMC_DAT0	PCIE2_RST*	219	220	I2S1_DOUT	I2S1_DOUT
SDMMC_DAT1	PCIE2_CLKREQ*	221	222	I2S1_DIN	I2S1_DIN
SDMMC_DAT2	PCIE3_RST*	223	224	I2S1_FS	I2S1_FS
SDMMC_DAT3	PCIE3_CLKREQ*	225	226	I2S1_SCLK	I2S1_SCLK
SDMMC_CMD	PCIE3_CLK_N	227	228	GPIO13	GPIO13
SDMMC_CLK	PCIE3_CLK_P	229	230	GPIO14	GPIO14
GND	GND	231	232	I2C2_SCL	I2C2_SCL
SHUTDOWN_REQ*	SHUTDOWN_REQ*	233	234	I2C2_SDA	I2C2_SDA
PMIC_BBAT	PMIC_BBAT	235	236	UART2_TXD	UART2_TXD
POWER_EN	POWER_EN	237	238	UART2_RXD	UART2_RXD
SYS_RESET*	SYS_RESET*	239	240	SLEEP/WAKE*	SLEEP/WAKE*
GND	GND	241	242	GND	GND
GND	GND	243	244	GND	GND
GND	GND	245	246	GND	GND
GND	GND	247	248	GND	GND
GND	GND	249	250	GND	GND
VDD_IN	VDD_IN	251	252	VDD_IN	VDD_IN
VDD_IN	VDD_IN	253	254	VDD_IN	VDD_IN
VDD_IN	VDD_IN	255	256	VDD_IN	VDD_IN
VDD_IN	VDD_IN	257	258	VDD_IN	VDD_IN
VDD_IN	VDD_IN	259	260	VDD_IN	VDD_IN

Chapter 5. Electrical, Mechanical, and Thermal Characteristics

5.1 Operating and Absolute Maximum Ratings

The parameters listed in the following table are specific to a temperature range and operating voltage. Operating the Jetson Orin NX beyond these parameters is not recommended.



Warning: Exceeding the listed conditions may damage and/or affect long-term reliability of the part. The Jetson Orin NX module should never be subjected to conditions extending beyond the ratings listed below

Table 5-1: Recommended Operating Conditions

Symbol	Parameter	Minimum	Typical	Maximum	Unit
VDDDC	VDD_IN (MODULE_ID low)	4.75	5	5.25	V
	VDD_IN (MODULE_ID high)	4.75	-	20	V
	PMIC_BBAT	1.85	-	5.5	V

Note: MAXN_SUPER at 40W for Jetson Orin NX requires minimum 8.0V to the VDD_IN.

Module ID strap: Indicates whether the module is a legacy type supporting only 5V on VDD_IN (tied to GND on the module) or an advanced type supporting from 5V to 20V on VDD_IN (floating on the module - pulled high on the carrier board).

Absolute maximum ratings describe stress conditions. These parameters do not set minimum and maximum operating conditions that will be tolerated over extended periods of time. If the device is exposed to these parameters for extended periods of time, performance is not guaranteed, and device reliability may be affected. It is not recommended to operate the Jetson Orin NX module under these conditions.

Table 5-2: Absolute Maximum Ratings

Symbol	Parameter	Minimum	Maximum	Unit	Notes
VDDMAX	VDD_IN (MODULE_ID low)	-0.5	5.5	V	
	VDD_IN (MODULE_ID high)	-0.5	20.5	V	

Symbol	Parameter	Minimum	Maximum	Unit	Notes
	PMIC_BBAT	-0.3	6.0	V	
IDDMAX	VDD_IN I _{max}	-	5	A	
VM_PIN	Voltage applied to any powered I/O pin	-0.5	VDD + 0.5	V	VDD + 0.5V when SYS_RESET* is high and associated I/O rail powered. I/O pins cannot be high (>0.5V) before SYS_RESET* goes high. When SYS_RESET* is low, the maximum voltage applied to any I/O pin is 0.5V
	DD pins configured as open drain	-0.5	3.63	V	The pin's output-driver must be set to open-drain mode.
TOP	Operating Temperature	-25	See Notes	°C	See the <i>Jetson Orin NX Series Thermal Design Guide</i> for details.
TSTG	Storage Temperature (ambient)				See Table 5-6
MMAX	Mounting Force	-	8.2	kgf 1	Maximum force applied to PCB. See the <i>Jetson Orin NX Series Thermal Design Guide</i> for additional details on mounting a thermal solution.

Note: kgf stands for kilogram-force.

5.2 Digital Logic

Voltages less than the minimum stated value can be interpreted as an undefined state or logic level low which may result in unreliable operation. Voltages exceeding the maximum value can damage and/or adversely affect device reliability.

Table 5-3: CMOS Pin Type DC Characteristics

Symbol	Description	Minimum	Maximum	Units
VIL	Input Low Voltage	-0.5	0.25 x VDD	V
VIH	Input High Voltage	0.75 x VDD	0.5 + VDD	V
VOL	Output Low Voltage (IOL = 1mA)	-	0.15 x VDD	V
VOH	Output High Voltage (IOH = -1mA)	0.85 x VDD	-	V

Table 5-4: Open Drain Pin Type DC Characteristics

Symbol	Description	Minimum	Maximum	Units
VIL	Input Low Voltage	-0.5	0.2 x VDD	V
VIH	Input High Voltage	0.8 x VDD	3.63	V
VOL	Output Low Voltage (IOL = 1mA)	-	0.15 x VDD	V
	I2C [1,0] Output Low Voltage (IOL = 2mA) (see note)	-	0.3 x VDD	V
VOH	Output High Voltage (IOH = -1mA)	0.7 x VDD	-	V



Note: I2C[1,0]_[SCL, SDA] pins pull-up to 3.3V through on module 2.2kΩ resistor.
I2C2_[SCL, SDA] pins pull-up to 1.8V through on module 2.2kΩ resistor.

5.3 Environmental and Mechanical Screening

Table 5-5: Environmental Testing

Test	Conditions	Reference Standard	Results
Temperature Humidity Biased	85°C / 85% RH, 168 hours, Power ON	JESD22-A101	PASS
Temperature Cycling	-40°C to 105°C, 375 cycles, non-operational	JESD22-A104, IPC9701	PASS
Temp/Humidity Cycle	25°C to 65°C, 93% RH, six cycles	NV Standard	PASS
Mechanical Shock – 140G Non-Op	140G, 2 msec, half sine, one shock/orientation, six orientations total, non-operational	JESD22-B110	PASS
Mechanical Shock – 50G Op	50G, 6 msec, half sine, three shocks/orientation, six orientations total, operational	IEC 600068 2-27	PASS
Connector Insertion Cycling	Insert/Withdraw SD card and connector, 30 cycles	EIA-364	PASS
Random Vibration – 2G Non-Op	5-500 Hz, 2 Grms, 1 hour/axis, three axes total, non-operational	IEC60068-2-64	PASS
Random Vibration – 1G Op	10-500 Hz, 1 Grms, 30 min/axis, three axes total, operational	IEC60068-2-64	PASS
Hard Boot	Power ON/OFF, ON for 150 sec, OFF for 30 sec 2000 cycles at 25°C 1000 cycles at -5°C 1000 cycles at 45°C	NV Standard	PASS
Operational Low Temp	-5°C, 24 hours, operational	NV Standard	PASS
Operational High Temp	45°C, 90%RH, 336 hours, operational	NV Standard	PASS
MTBF / Failure Rate	Controlled Environment (GB), T = 35°C or 50°C, CL = 90%	Telcordia (TelC4) SR-332, ISSUE4 Parts Count (Method 1)	See notes below
MTBF / Failure Rate	Uncontrolled Environment (GF) T = 35°C or 50°C, CL = 90%	Telcordia (TelC4) SR-332, ISSUE4 Parts Count (Method 1)	See notes below



Notes: MTBF numbers below are based on Telcordia (TelC4) SR-332, ISSUE4, Calculation Methodology:

Parts Count (Method 1), UCL = 90%, Quality level: II

> Original

- Orin NX 16GB: GB at 35°C: 1,922,650 hours / GB at 50°C: 1,341,647 hours / GF at 35°C: 1,635,452 hours / GF at 50°C: 1,225,718 hours
- Orin NX 8GB: GB at 35°C: 3,470,756 hours / GB at 50°C: 1,794,536 hours / GF at 35°C: 2,526,862 hours / GF at 50°C: 1,241,015 hours

> MAXN_SUPER mode

- Orin NX 16GB: GB at 35°C: 1,922,650 hours / GB at 50°C: 1,341,647 hours / GF at 35°C: 1,635,452 hours / GF at 50°C: 1,036,357 hours
- Orin NX 8GB: GB at 35°C: 2,116,858 hours / GB at 50°C: 1,394,572 hours / GF at 35°C: 1,744,140 hours / GF at 50°C: 1,046,233 hours

5.4 Storage and Handling

Table 5-6: Typical Handling and Storage Environment

Parameter	Description
Storage temperature (ambient) ¹	18°C to 30°C
Storage humidity	30% to 70% RH
Storage life ²	5 years from NVIDIA shipment date to customers



Note: Transportation is a limited range of time that is covered by AEC grade 3 specs (-40°C to 85°C). Longer term storage at hubs, distribution points, and warehousing where climate controls are in place should follow conditions mentioned above.

Duration based on product being packed and stored in a controlled environment without power on.

5.5 Module Drawing and Dimensions

Module Size: 69.6 mm x 45 mm

Module Weight: 0.028kg

Note:

- > All dimensions are in millimeters unless otherwise specified.
- > Tolerances are: .X ± 0.25, XX ± is 0.1, Angle ± is 1.

Figure 5-1: Top View

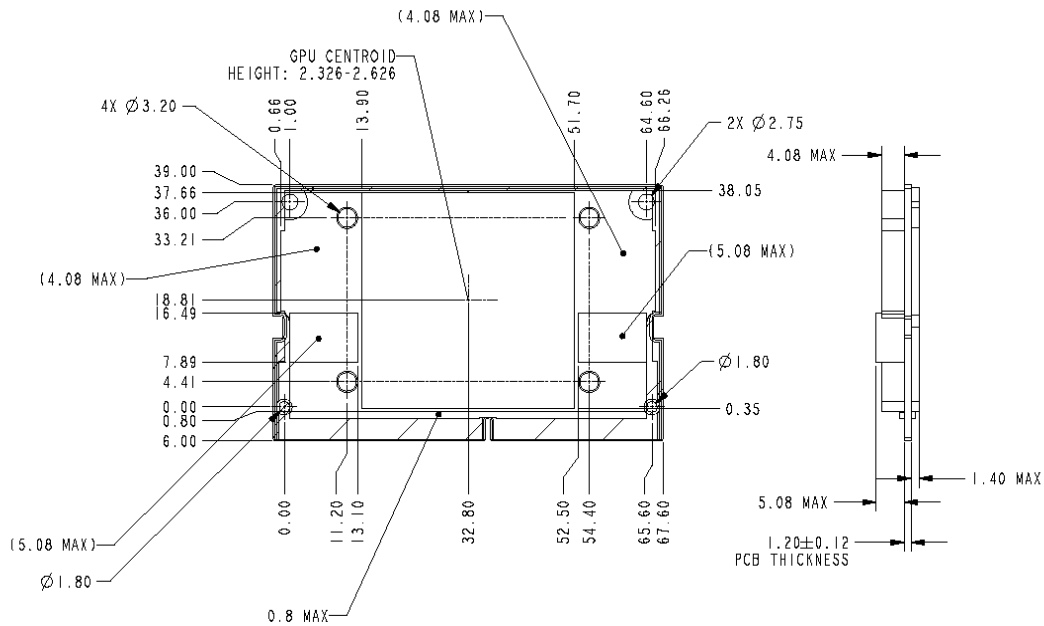
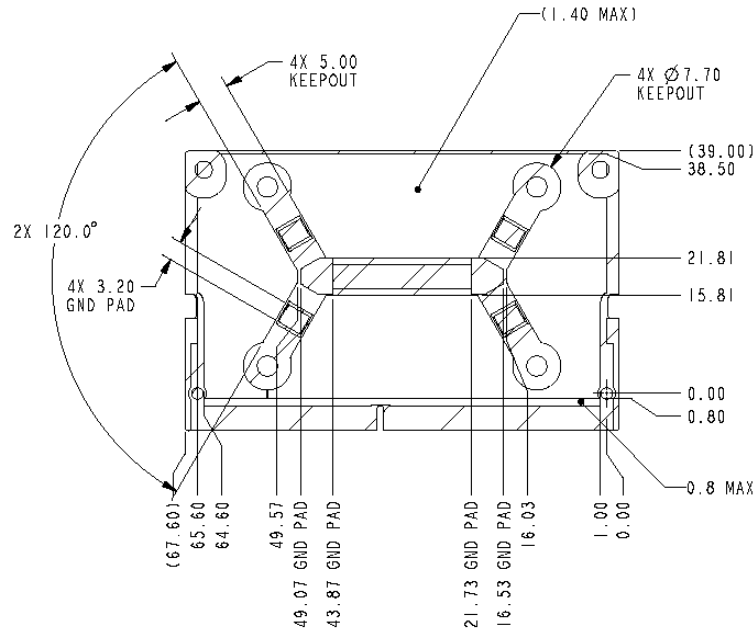

Figure 5-2: Bottom View



Notice

This document is provided for information purposes only and shall not be regarded as a warranty of a certain functionality, condition, or quality of a product. NVIDIA Corporation ("NVIDIA") makes no representations or warranties, expressed or implied, as to the accuracy or completeness of the information contained in this document and assumes no responsibility for any errors contained herein. NVIDIA shall have no liability for the consequences or use of such information or for any infringement of patents or other rights of third parties that may result from its use. This document is not a commitment to develop, release, or deliver any Material (defined below), code, or functionality.

NVIDIA reserves the right to make corrections, modifications, enhancements, improvements, and any other changes to this document, at any time without notice.

Customer should obtain the latest relevant information before placing orders and should verify that such information is current and complete.

NVIDIA products are sold subject to the NVIDIA standard terms and conditions of sale supplied at the time of order acknowledgement, unless otherwise agreed in an individual sales agreement signed by authorized representatives of NVIDIA and customer ("Terms of Sale"). NVIDIA hereby expressly objects to applying any customer general terms and conditions with regards to the purchase of the NVIDIA product referenced in this document. No contractual obligations are formed either directly or indirectly by this document.

NVIDIA products are not designed, authorized, or warranted to be suitable for use in medical, military, aircraft, space, or life support equipment, nor in applications where failure or malfunction of the NVIDIA product can reasonably be expected to result in personal injury, death, or property or environmental damage. NVIDIA accepts no liability for inclusion and/or use of NVIDIA products in such equipment or applications and therefore such inclusion and/or use is at customer's own risk.

NVIDIA makes no representation or warranty that products based on this document will be suitable for any specified use. Testing of all parameters of each product is not necessarily performed by NVIDIA. It is customer's sole responsibility to evaluate and determine the applicability of any information contained in this document, ensure the product is suitable and fit for the application planned by customer, and perform the necessary testing for the application in order to avoid a default of the application or the product. Weaknesses in customer's product designs may affect the quality and reliability of the NVIDIA product and may result in additional or different conditions and/or requirements beyond those contained in this document. NVIDIA accepts no liability related to any default, damage, costs, or problem which may be based on or attributable to: (i) the use of the NVIDIA product in any manner that is contrary to this document or (ii) customer product designs.

No license, either expressed or implied, is granted under any NVIDIA patent right, copyright, or other NVIDIA intellectual property right under this document. Information published by NVIDIA regarding third-party products or services does not constitute a license from NVIDIA to use such products or services or a warranty or endorsement thereof. Use of such information may require a license from a third party under the patents or other intellectual property rights of the third party, or a license from NVIDIA under the patents or other intellectual property rights of NVIDIA.

Reproduction of information in this document is permissible only if approved in advance by NVIDIA in writing, reproduced without alteration and in full compliance with all applicable export laws and regulations, and accompanied by all associated conditions, limitations, and notices.

THIS DOCUMENT AND ALL NVIDIA DESIGN SPECIFICATIONS, REFERENCE BOARDS, FILES, DRAWINGS, DIAGNOSTICS, LISTS, AND OTHER DOCUMENTS (TOGETHER AND SEPARATELY, "MATERIALS") ARE BEING PROVIDED "AS IS." NVIDIA MAKES NO WARRANTIES, EXPRESSED, IMPLIED, STATUTORY, OR OTHERWISE WITH RESPECT TO THE MATERIALS, AND EXPRESSLY DISCLAIMS ALL IMPLIED WARRANTIES OF NON-INFRINGEMENT, MERCHANTABILITY, AND FITNESS FOR A PARTICULAR PURPOSE. TO THE EXTENT NOT PROHIBITED BY LAW, IN NO EVENT WILL NVIDIA BE LIABLE FOR ANY DAMAGES, INCLUDING WITHOUT LIMITATION ANY DIRECT, INDIRECT, SPECIAL, INCIDENTAL, PUNITIVE, OR CONSEQUENTIAL DAMAGES, HOWEVER CAUSED AND REGARDLESS OF THE THEORY OF LIABILITY, ARISING OUT OF ANY USE OF THIS DOCUMENT, EVEN IF NVIDIA HAS BEEN ADVISED OF THE POSSIBILITY OF SUCH DAMAGES. Notwithstanding any damages that customer might incur for any reason whatsoever, NVIDIA's aggregate and cumulative liability towards customer for the products described herein shall be limited in accordance with the Terms of Sale for the product.

Trademarks

NVIDIA, the NVIDIA logo, are trademarks and/or registered trademarks of NVIDIA Corporation in the U.S. and other countries. Other company and product names may be trademarks of the respective companies with which they are associated.

VESA DisplayPort

DisplayPort and DisplayPort Compliance Logo, DisplayPort Compliance Logo for Dual-mode Sources, and DisplayPort Compliance Logo for Active Cables are trademarks owned by the Video Electronics Standards Association in the United States and other countries.

HDMI

HDMI, the HDMI logo, and High-Definition Multimedia Interface are trademarks or registered trademarks of HDMI Licensing LLC.

Arm

Arm, AMBA, and ARM Powered are registered trademarks of Arm Limited. Cortex, MPCore, and Mali are trademarks of Arm Limited. All other brands or product names are the property of their respective holders. "Arm" is used to represent ARM Holdings plc; its operating company Arm Limited; and the regional subsidiaries Arm Inc.; Arm KK; Arm Korea Limited.; Arm Taiwan Limited; Arm France SAS; Arm Consulting (Shanghai) Co. Ltd.; Arm Germany GmbH; Arm Embedded Technologies Pvt. Ltd.; Arm Norway, AS, and Arm Sweden AB.

OpenCL

OpenCL is a trademark of Apple Inc. used under license to the Khronos Group Inc.

Copyright

© 2021–2026 NVIDIA Corporation. All rights reserved.