

Dear customer

LAPIS Semiconductor Co., Ltd. ("LAPIS Semiconductor"), on the 1<sup>st</sup> day of October, 2020, implemented the incorporation-type company split (shinsetsu-bunkatsu) in which LAPIS established a new company, LAPIS Technology Co., Ltd. ("LAPIS Technology") and LAPIS Technology succeeded LAPIS Semiconductor's LSI business.

Therefore, all references to "LAPIS Semiconductor Co., Ltd.", "LAPIS Semiconductor" and/or "LAPIS" in this document shall be replaced with "LAPIS Technology Co., Ltd."

Furthermore, there are no changes to the documents relating to our products other than the company name, the company trademark, logo, etc.

Thank you for your understanding.

LAPIS Technology Co., Ltd.

October 1, 2020

# ML62Q1400 Group

16-bit micro controller

## GENERAL DESCRIPTION

ML62Q1400 Group is a high performance CMOS 16-bit microcontroller equipped with an 16-bit CPU nX-U16/100 and integrated with program memory(Flash memory), data memory(RAM), data Flash and rich peripheral functions such as the multiplier/divider, CRC operator, DMA controller, clock generator, Simplified RTC, timer, UART, synchronous serial port, I<sup>2</sup>C bus interface unit, buzzer, Voltage Level Supervisor(VSL), successive approximation type A/D converter, D/A converter, analog comparator, safety function and etc.

The CPU nX-U16/100 is capable of efficient instruction execution in 1-instruction 1-clock mode by pipeline architecture parallel processing.

The built-in on-chip debug function enables debugging and programming the software. Also, ISP(In-System Programming) function supports the Flash programming in production line.

The ML62Q1400 Group has five packages (48pin - 64pin) and five kinds of memory sizes(32Kbyte - 64Kbyte).

Table 1 ML62Q1400 Group Product List

Program memory	Data memory (RAM)	Data Flash	48pin TQFP48	52pin TQFP52	64pin QFP64 TQFP64
64Kbyte	4Kbyte	2Kbyte	ML62Q1432	ML62Q1442	ML62Q1452
48Kbyte	4Kbyte	2Kbyte	ML62Q1431	ML62Q1441	ML62Q1451
32Kbyte	4Kbyte	2Kbyte	ML62Q1430	ML62Q1440	ML62Q1450

## FEATURES

- CPU
  - 16-bit RISC CPU (CPU name: nX-U16/100)
  - Instruction system: 16-bit length instruction
  - Instruction set: Transfer, arithmetic operations, comparison, logic operations, multiplication/division, bit manipulations, bit logic operations, jump, conditional jump, call return stack manipulations, arithmetic shift, and so on
  - On-chip debug function built-in (supported by LAPIS on-chip debug emulator EASE1000)
  - ISP (In-System Programming) function built-in
  - Minimum instruction execution time  
 30.5 μs (at 32.768 KHz system clock)  
 62.5ns/41.6ns (at 16 MHz/24MHz system clock)
- Coprocessor for multiplication and division
  - Multiplication: 16bit × 16bit (operation time 4 cycles)
  - Division: 32bit / 16bit (operation time 8 cycles)
  - Division: 32bit / 32bit (operation time 16 cycles)
  - Multiply-accumulate (non-saturating): 16bit × 16bit + 32bit (operation time 4 cycles)
  - Multiply-accumulate (saturating): 16bit × 16bit + 32bit (operation time 4 cycles)



- Operating voltage and temperature
  - Operating voltage: VDD = 1.6 to 5.5 V
  - Operating temperature: -40 to +105 °C
- Internal memory
  - Program Flash memory area
    - Rewrite count: 100 cycles
    - Rewrite unit: 32bit(4byte)
    - Erase unit: 16Kbyte/1Kbyte
    - Erase/Rewrite temperature: 0°C to +40°C
  - Data Flash memory area
    - Rewrite count 10,000 cycles
    - Rewrite unit: 8bit(1byte)
    - Erase unit: 2Kbyte/128byte
    - Erase/Rewrite temperature: -40°C to +85°C
    - Back Ground Operation(CPU can work while erasing and rewriting)
  - Data RAM area
    - Rewrite unit: 8bit/16bit(1byte/2byte)
    - Parity check function (Parity error reset is generatable)
- Clock
  - Low-speed clock
    - Internal low-speed RC oscillation: Approx.32.768 KHz
    - External low-speed crystal oscillation: 32.768 KHz crystal resonator is connectable
    - 4 modes is available for the crystal oscillation
      - Tough mode: Largest oscillation allowance to make highest resistance against leakage between the pins
      - Standard mode: Standard oscillation allowance and current consumption
      - Low power current mode: Smaller oscillation allowance than standard mode to make lower current consumption
  - High-speed clock
    - PLL oscillation: 32MHz/24MHz/16MHz is selectable by code option
  - WDT(Watch Dog Timer) clock
    - Internal low-speed RC oscillation: Aprox. 1kHz
    - The WDT independent clock or the divided clock of internal low-speed 32.768kHz RC oscillation clock is selectable by the code option.
- Reset
  - RESET\_N pin reset
  - Reset by power-on detection
  - Reset by the 2<sup>nd</sup> watchdog timer (WDT) overflow
  - Reset by WDT counter clear during the clear invalid period
  - Reset by RAM parity error
  - Reset by unused ROM access
  - Reset by voltage level detection (VLS)
  - The software reset by BRK instruction (reset CPU only)

- Power management
  - HALT mode: CPU stops executing instruction, clock oscillations and peripheral circuits remain previous states
  - HALT-H mode: CPU stops executing instruction, high-speed clock oscillation stops and peripheral circuits working with low-speed clock remain previous states
  - STOP mode: CPU stops executing instruction, both high-speed oscillation and low-speed oscillation stop.
  - STOP-D mode: CPU stops executing instruction, both high-speed oscillation and low-speed oscillation stop. The internal regulator's output voltage ( $V_{DDL}$ ) goes down to reduce the current consumption.
  - Clock gear: The frequency of high-speed system clock can be changed by software (1/1, 1/2, 1/4, 1/8, 1/16 or 1/32 of the oscillation clock)
  - Block Control Function: Powers down the circuits of unused function blocks (reset the block or stop supplying the clock)
- Interrupt controller
  - Non-maskable interrupt source: 1 (Internal sources: WDT)
  - Maskable interrupt sources: max.37 (Internal sources: max.29, External sources: 8)
  - Four step interrupt levels
- Watchdog timer(WDT)
  - Operation clock: 1kHz WDT independent clock or 32.768kHz RC oscillation clock, selectable by code option
  - Overflow period: 8 types selectable (8ms, 16ms, 32ms, 64ms, 125ms, 500ms, 2000ms and 8000ms @32.768kHz)
  - WDT counter clear enable period : 50%, 75% or 100% of overflow period
    - When 100% of overflow period is selected,  
The first overflow generates an interrupt, and the second overflow generates a reset.
    - When 50% or 70% of overflow period is selected,  
Clearing the WDT counter out of the enable period generates the WDT invalid clear reset.
  - WDT operation : Enable or disable is selectable by code option
  - Readable WDT counter (WDT counter monitor function)
- DMA(Direct Memory Access) controller
  - Channel : 2ch
  - Operation mode : Wait mode only (cannot be used in No wait mode)
  - Transfer unit: 8bit/16bit
  - Max. transfer count: 1024 time
  - Transfer type: 2 cycle transfer
  - Transfer mode: Single transfer mode
    - Fixed address, address increments and address decrements
  - Transfer target: SFR/RAM  $\leftrightarrow$  SFR/RAM (Transfer from/to Flash is not supported)
  - Transfer request: Serial unit interrupt, A/D interrupt and 16bit timer interrupt
- Time base counter
  - Devide the Low-speed clock(LSCLK) and generate 32.768kHz~1Hz internal pulse signals
  - Priodical interrupt  $\times$  3 selectable from 8 frequencies (128Hz, 64Hz, 32Hz, 16Hz, 8Hz, 4Hz, 2Hz and 1Hz)
  - The time base clock output (1Hz or 2Hz) from general purpose ports (TBCOUT1).
- Simplified RTC
  - Channel: 1 ch
  - Count by one second from “00 min. 00 sec” to “59 min. 59 sec”
  - One interrupt occurrence is selectable from four periodical interrupt requests (0.5sec, 1sec, 30sec or 60sec)
  - Protect function for incorrect writing the minutes and second.

- Functional timer(FTM)
  - Channel: 6ch
  - Timer one shot mode and repeat mode, Capture mode, PWM mode1 and PWM mode 2(complementary output)
  - Same start/stop is available with different channels  
(This function is not available with 16bit General Timer)
  - Event trigger (external interrupts, analog comparator interrupts, 16bit general timer interrupts and Functional timer interrupts)
  - Delay counter (for generating dead time)
  - Available to specify division ratio of counter clock channel by channel
- 16bit General timers
  - Channel: 6ch
  - 8 bits timer mode and 16-bit timer mode (1ch 16-bit timer is configurable as 2ch 8-bit timer)
  - Same start/stop is available with different channels  
(This function is not available with Functional Timer)
  - Timer output (toggled by overflow)
  - Available to specify division ratio of counter clock channel by channel
- Serial communication unit
  - Channel: Max. 2ch
  - Synchronous Serial Port or UART is selectable in each channel

< Synchronous Serial Port >

  - Master/slave selectable
  - LSB first/MSB first selectable
  - 8-bit length/16-bit length selectable

< UART >

  - Full-duplex communication x 2 ch(One Full-duplex UART is configurable as two half-duplex UARTs)
  - 5~8 bit length, parity/no parity, odd parity/even parity, 1 stop bit/2 stop bits
  - Positive logic/negative logic selectable
  - LSB first/MSB first selectable
  - Internal baud rate generator (1bps ~ 2Mbps)
- I<sup>2</sup>C bus interface unit (Master/Slave)
  - Channel: 1ch
  - Master or Slave mode is selectable

< Master function >

  - Standard mode (100 kbit/s), fast mode (400 kbit/s) and 1Mbps mode(1Mbit/s)
  - Handshake (Clock synchronization)
  - 7bit address format (10bit address format is supported)

< Slave function >

  - Standard mode (100 kbit/s), fast mode (400 kbit/s) and 1Mbps mode(1Mbit/s)
  - Handshake (Clock synchronization)
  - 7bit address format (10bit address format is supported)
- I<sup>2</sup>C bus interface (Master only)
  - Channel: 2ch
  - Standard mode (100 kbit/s), fast mode (400 kbit/s) and 1Mbps mode(1Mbit/s)
  - Handshake (Clock synchronization)
  - 7bit address format (10bit address format is supported)
- General-purpose ports (GPIO)
  - I/O port: Max. 58 (Including one pin for on-chip debug and pins for other shared functions)
  - Input port: Max. 2(Including a shared function)
  - External interrupt function × 8
  - LED driver port : Max. 57
  - Carrier frequency output function (used for IR communication)

- Successive approximation type A/D converter
  - Channel: Max.12ch
  - Resolution: 10bit
  - Conversion time: Selectable 2.25 $\mu$ s (min) /channel (When the conversion clock is 8MHz)
  - Reference voltages are selectable  
(VDD pin input voltage / Internal reference voltage(Approx. 1.55V) / External reference voltage (V<sub>REF</sub> pin))
  - Scan function (repeat conversion)
  - One result register for each channel
  - Interrupt by threshold of conversion result
  - Temperature sensor for low-speed RC oscillation adjustment
  
- Voltage level supervisor (VSL)
  - Accuracy:  $\pm 4^{\circ}\text{C}$
  - Threshold voltage: 12 values selectable (1.85V ~ 4.00V)
  - Voltage level detection reset (VLS reset)
  - Voltage level detection interrupt (VLS0 interrupt)
  
- Analog comparator
  - Channel: 2ch
  - Interrupts allow edge selection and sampling selection
  - An external or an internal reference voltage is selectable
  
- D/A converter
  - Channel: 1ch
  - Resolution: 8bit
  - Output impedance: 6k ohm(Typ.)
  - R-2R ladder method
  
- Buzzer
  - 4 buzzer mode (Repeat sound, Single sound, Intermittent sound 1 and Intermittent sound 2)
  - 8 frequencies (4.096kHz to 293Hz)
  - 15 step duty (1/16 to 15/16)
  - Selectable the logic of buzzer output pin (Positive or Negative logic)
  
- CRC(Cycle Redundancy Check) operation function
  - Generation equation:  $X^{16}+X^{12}+X^5+1$
  - LSB first
  - Automatic CRC mode: Automatic CRC calculation with data of program memory in HALT mode

- Safety Function
  - RAM/SFR guard
  - Automatic CRC calculation with data of program memory
  - RAM parity error detection
  - ROM unused area access reset
  - Clock mutual check
  - WDT counter check
  - Successive approximation type A/D converter test
  - UART test
  - Synchronous serial test
  - I<sup>2</sup>C test
  - GPIO test
  
- Shipping package
  - 48-pin plastic TQFP  
ML62Q1430/1431/1432-xxxTB (Blank part: ML62Q1430/1431/1432-NNNTB)
  
  - 52-pin plastic TQFP  
ML62Q1440/1441/1442-xxxTB (Blank part: ML62Q1440/1441/1442-NNNTB)
  
  - 64-pin plastic TQFP  
ML62Q1450/1451/1452-xxxTB (Blank part: ML62Q1450/1451/1452-NNNTB)
  
  - 64-pin plastic QFP  
ML62Q1450/1451/1452-xxxGA (Blank part: ML62Q1450/1451/1452-NNNGA)

xxx: ROM code number

## ML62Q1400 Group how to read the part number

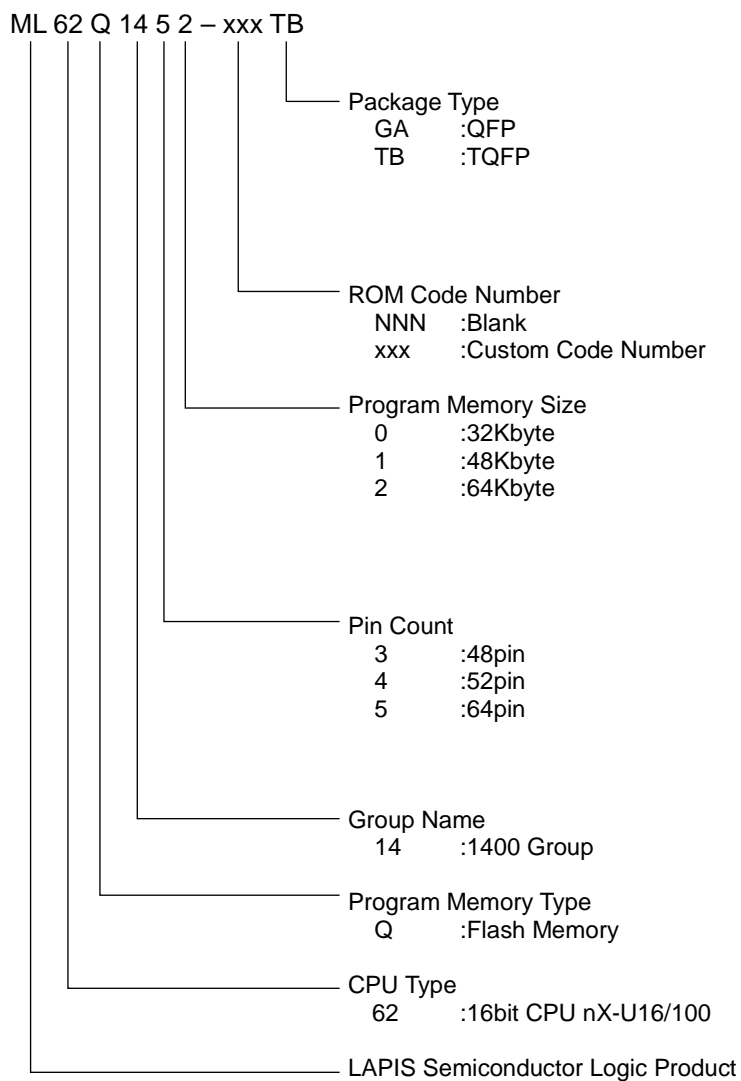

Figure 1 ML62Q1400 Group Part Number

ML62Q1400 Group Main Function List

Table 2 ML62Q1400 Group Main Function List

Part number	Pin				Interrupt			Timer			Serial			Analog			
	Total pin-counts	Power pin counts	Reset Input pin	Input port * <sup>3</sup>	I/O port	LED drive port	Internal interrupt	External interrupt	Functional Timer [channel]	16bit General I Timer [channel] * <sup>1</sup>	Simplified RTC [channel]	Full-duplex UART or Synchronous serial [channel] * <sup>2</sup>	I <sup>2</sup> C bus unit (Master/Slave) [channel]	I <sup>2</sup> C bus interface (Master only) [channel]	10bit Successive type A/D converter [channel]	Analog comparator [channel]	Analog comparator [input pin]
ML62Q1430	48	3	1	2	42	30	8	6	6	1	2	1	2	12	2	4	1
ML62Q1431					42												
ML62Q1432					42												
ML62Q1440	52	3	1	2	46	30	8	6	6	1	2	1	2	12	2	4	1
ML62Q1441					46												
ML62Q1442					46												
ML62Q1450	64	3	1	2	58	30	8	6	6	1	2	1	2	12	2	4	1
ML62Q1451					58												
ML62Q1452					58												

\*<sup>1</sup> : One 16bit timer is configurable as two 8bit timers

\*<sup>2</sup> : Full-duplex UART and Synchronous Serial Port can not be used simultaneously in the same channel.  
One Full-duplexUART is configurable as two half-duplex UARTs.

\*<sup>3</sup> : Shared with pins for crystal oscillation

BLOCK DIAGRAM

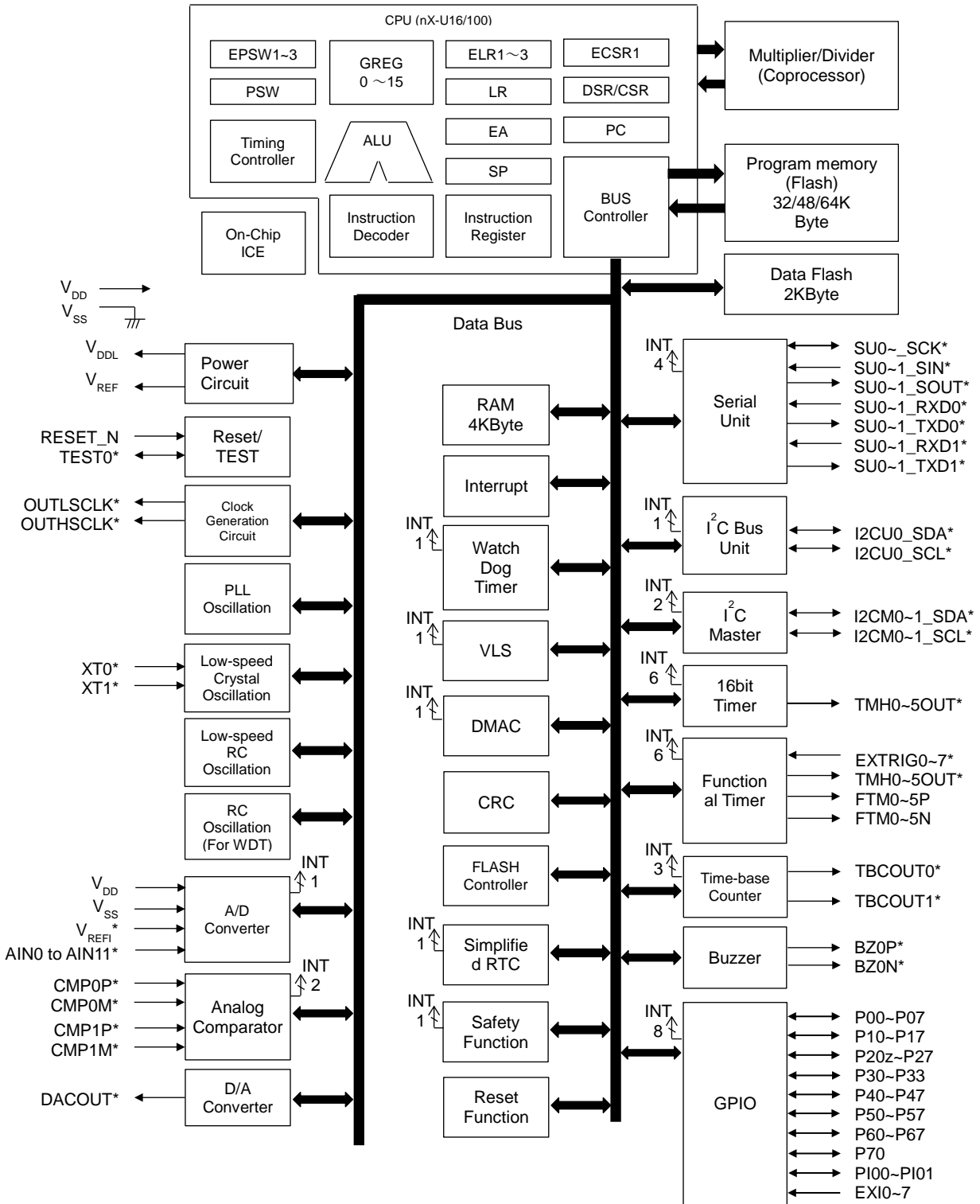

\* : indicates the shared function of general ports.

Figure 2 ML62Q1400 Group Block Diagram

## PIN CONFIGURATION

### Pin Layout of ML62Q1430/1431/1432 48pin TQFP Package

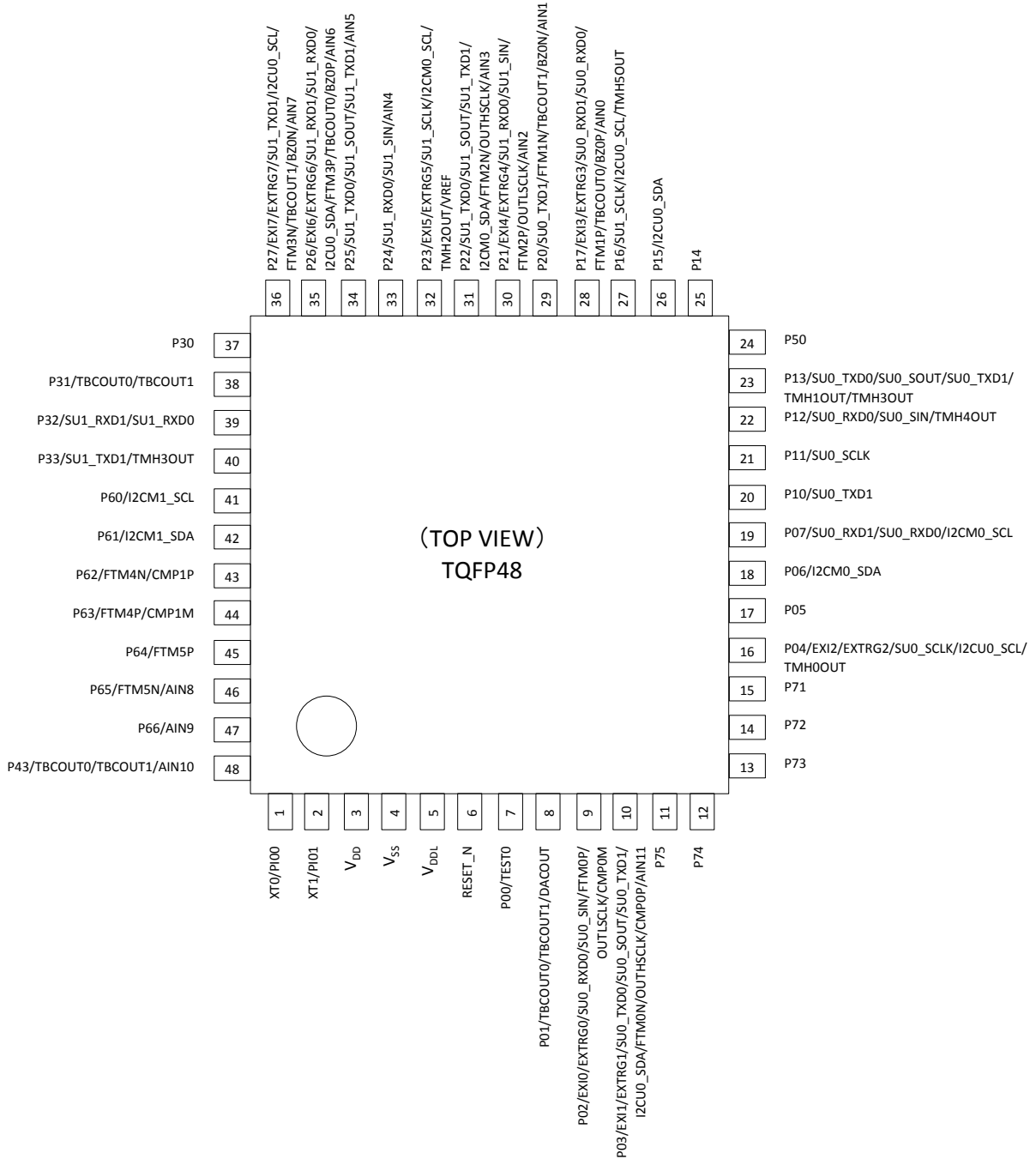

Figure 3 Pin Layout of ML62Q1430/1431/1432 48pin TQFP Package

## Pin Layout of ML62Q1440/1441/1442 52pin TQFP Package

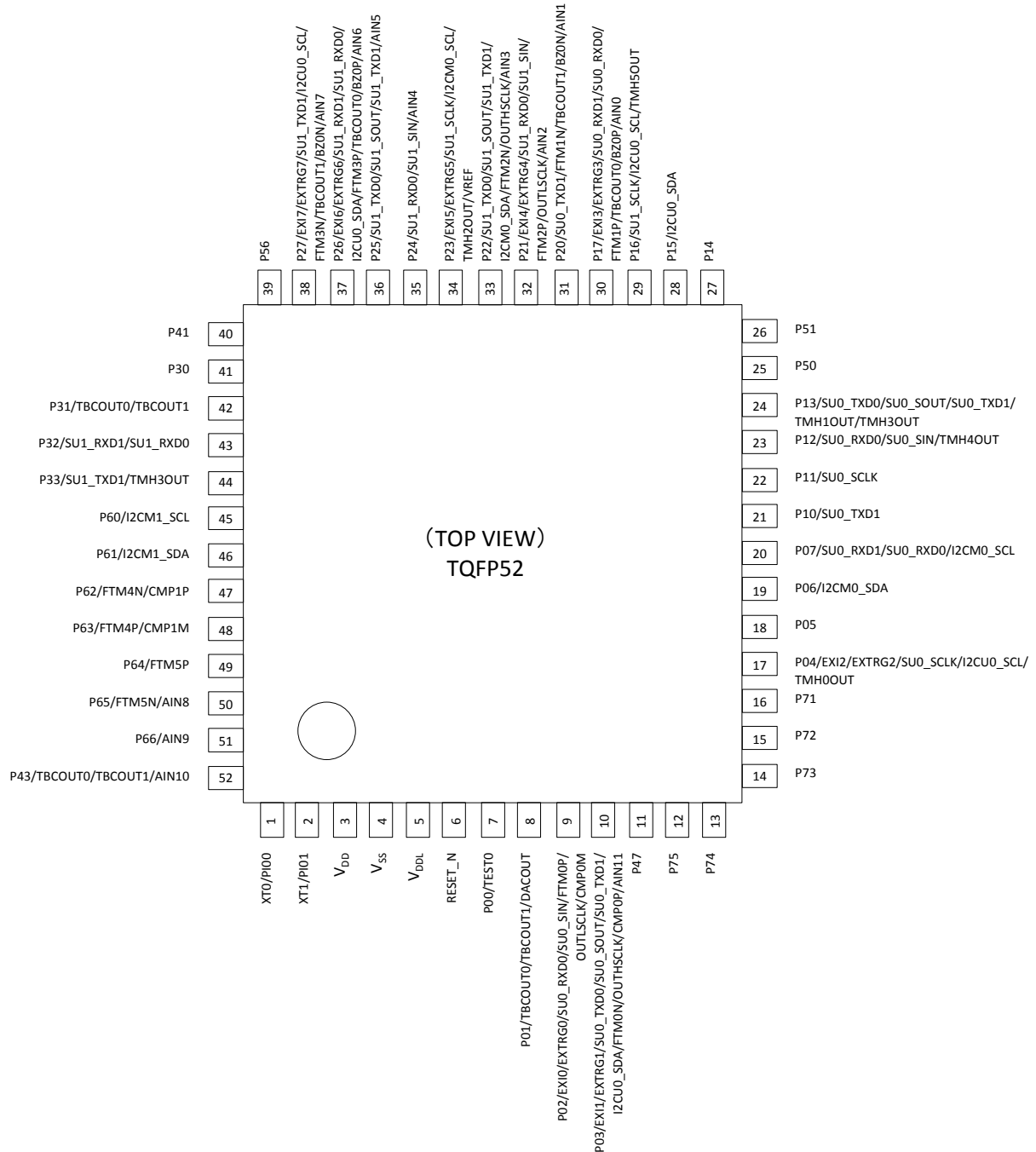

Figure 4 Pin Layout of ML62Q1440/1441/1442 52pin TQFP52 Package

## Pin Layout of ML62Q1450/1451/1452 64pin TQFP/QFP Package

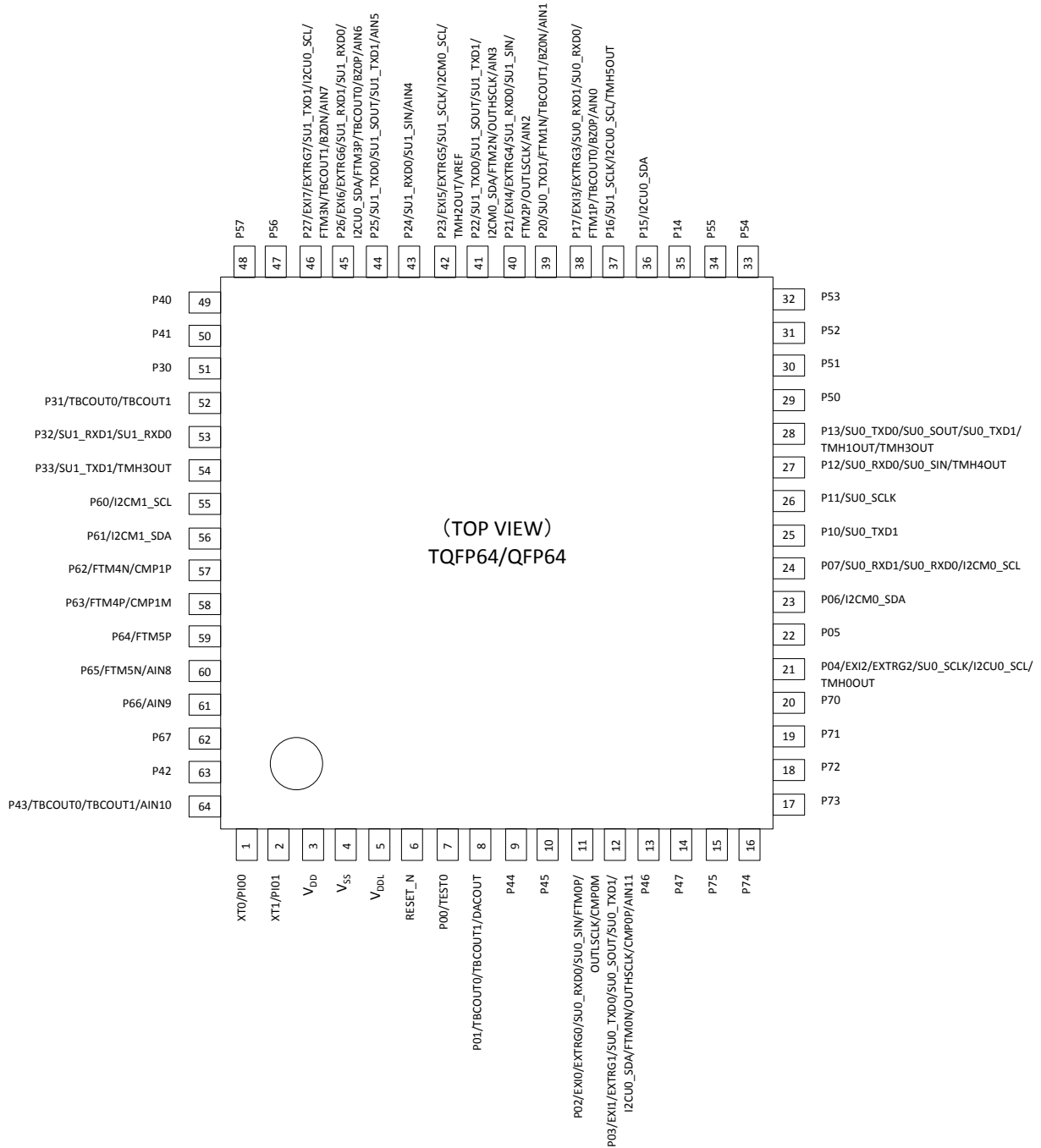

Figure 5 Pin Layout of ML62Q1450/1451/1452 64pin TQFP/QFP Package

PIN LIST

Table 3 Pin List (1/10)

48Pin No.	52Pin No.	64Pin No. (QFP)	64Pin No. (TQFP)	Pn name	Primary function	Shared function	
3	3	3	3	V <sub>DD</sub>	Positive power pin	—	
4	4	4	4	V <sub>SS</sub>	Negative power pin	—	
5	5	5	5	V <sub>DDL</sub>	Internal regulator output	—	
6	6	6	6	RESET_N (I)	Reset input Used for on-chip debug interface	—	
1	1	1	1	XT0 / PI00 (I)	General Input pin	Low speed crystal resonator connection pin	
2	2	2	2	XT1 / PI01 (I)	General Input pin	Low speed crystal resonator connection pin	
7	7	7	7	P00/ TEST0 (I/O)	General I/O pin Used for on-chip debug interface (Not available to use as I/O pin when connecting to the on-chip emulator)	—	
8	8	8	8	P01/ DACOUT (I/O)	General I/O pin D/A converter output pin	2 <sup>nd</sup> function	—
						3 <sup>rd</sup> function	—
						4 <sup>th</sup> function	—
						5 <sup>th</sup> function	—
						6 <sup>th</sup> function	TBCOUT0
						7 <sup>th</sup> function	TBCOUT1
						8 <sup>th</sup> function	—
9	9	11	11	P02/ EXI0/ EXTRG0 (I/O)	General I/O pin External interrupt Functional timer external trigger	2 <sup>nd</sup> function	SU0_RXD0/SU0_SIN
						3 <sup>rd</sup> function	—
						4 <sup>th</sup> function	—
						5 <sup>th</sup> function	FTM0P
						6 <sup>th</sup> function	OUTLSCLK
						7 <sup>th</sup> function	CMP0M
						8 <sup>th</sup> function	—
10	10	12	12	P03/ EXI1/ EXTRG1 (I/O)	General I/O pin External interrupt Functional timer external trigger	2 <sup>nd</sup> function	SU0_TXD0/SU0_SOUT
						3 <sup>rd</sup> function	SU0_TXD1
						4 <sup>th</sup> function	I2CU0_SDA
						5 <sup>th</sup> function	FTM0N
						6 <sup>th</sup> function	OUTHCLK
						7 <sup>th</sup> function	CMP0P
						8 <sup>th</sup> function	AIN11
16	17	21	21	P04/ EXI2/ EXTRG2/ COM0 (I/O)	General I/O pin External interrupt Functional timer external trigger	2 <sup>nd</sup> function	SU0_SCLK
						3 <sup>rd</sup> function	—
						4 <sup>th</sup> function	I2CU0_SCL
						5 <sup>th</sup> function	TMH0OUT
						6 <sup>th</sup> function	—
						7 <sup>th</sup> function	—
						8 <sup>th</sup> function	—
17	18	22	22	P05/ (I/O)	General I/O pin	2 <sup>nd</sup> function	—
						3 <sup>rd</sup> function	—
						4 <sup>th</sup> function	—
						5 <sup>th</sup> function	—
						6 <sup>th</sup> function	—
						7 <sup>th</sup> function	—
						8 <sup>th</sup> function	—

Table 3 Pin List (2/10)

48Pin No.	52Pin No.	64Pin No. (QFP)	64Pin No. (TQFP)	Pn name	Primary function	Shared function	
18	19	23	23	P06 / (I/O)	General I/O pin	2 <sup>nd</sup> function	—
						3 <sup>rd</sup> function	—
						4 <sup>th</sup> function	I2CM0_SDA
						5 <sup>th</sup> function	—
						6 <sup>th</sup> function	—
						7 <sup>th</sup> function	—
						8 <sup>th</sup> function	—
						19	20
3 <sup>rd</sup> function	SU0_RXD0						
4 <sup>th</sup> function	I2CM0_SCL						
5 <sup>th</sup> function	—						
6 <sup>th</sup> function	—						
7 <sup>th</sup> function	—						
8 <sup>th</sup> function	—						
20	21	25	25	P10 / (I/O)	General I/O pin		
						3 <sup>rd</sup> function	—
						4 <sup>th</sup> function	—
						5 <sup>th</sup> function	—
						6 <sup>th</sup> function	—
						7 <sup>th</sup> function	—
						8 <sup>th</sup> function	—
						21	22
3 <sup>rd</sup> function	—						
4 <sup>th</sup> function	—						
5 <sup>th</sup> function	—						
6 <sup>th</sup> function	—						
7 <sup>th</sup> function	—						
8 <sup>th</sup> function	—						
22	23	27	27	P12 (I/O)	General I/O pin		
						3 <sup>rd</sup> function	—
						4 <sup>th</sup> function	—
						5 <sup>th</sup> function	TMH4OUT
						6 <sup>th</sup> function	—
						7 <sup>th</sup> function	—
						8 <sup>th</sup> function	—
						23	24
3 <sup>rd</sup> function	SU0_TXD1						
4 <sup>th</sup> function	—						
5 <sup>th</sup> function	TMH1OUT						
6 <sup>th</sup> function	—						
7 <sup>th</sup> function	TMH3OUT						
8 <sup>th</sup> function	—						
25	27	35	35	P14 / (I/O)	General I/O pin		
						3 <sup>rd</sup> function	—
						4 <sup>th</sup> function	—
						5 <sup>th</sup> function	—
						6 <sup>th</sup> function	—
						7 <sup>th</sup> function	—
						8 <sup>th</sup> function	—

Table 3 Pin List (3/10)

48Pin No.	52Pin No.	64Pin No. (QFP)	64Pin No. (TOPP).	Pn name	Primary function	Shared function	
26	28	36	36	P15 / (I/O)	General I/O pin	2 <sup>nd</sup> function	—
						3 <sup>rd</sup> function	—
						4 <sup>th</sup> function	I2CU0_SDA
						5 <sup>th</sup> function	—
						6 <sup>th</sup> function	—
						7 <sup>th</sup> function	—
27	29	37	37	P16 / (I/O)	General I/O pin	2 <sup>nd</sup> function	SU1_SCLK
						3 <sup>rd</sup> function	—
						4 <sup>th</sup> function	I2CU0_SCL
						5 <sup>th</sup> function	TMH5OUT
						6 <sup>th</sup> function	—
						7 <sup>th</sup> function	—
28	30	38	38	P17 / EXI3/ EXTRG3 / (I/O)	General I/O pin External interrupt Functional timer external trigger	2 <sup>nd</sup> function	SU0_RXD1
						3 <sup>rd</sup> function	SU0_RXD0
						4 <sup>th</sup> function	—
						5 <sup>th</sup> function	FTM1P
						6 <sup>th</sup> function	TBCOUT0
						7 <sup>th</sup> function	BZ0P
29	31	39	39	P20 / (I/O)	General I/O pin	8 <sup>th</sup> function	AIN0
						2 <sup>nd</sup> function	SU0_TXD1
						3 <sup>rd</sup> function	—
						4 <sup>th</sup> function	—
						5 <sup>th</sup> function	FTM1N
						6 <sup>th</sup> function	TBCOUT1
30	32	40	40	P21 / EXI4 / EXTRG4 / (I/O)	General I/O pin External interrupt Functional timer external trigger	7 <sup>th</sup> function	BZ0N
						8 <sup>th</sup> function	AIN1
						2 <sup>nd</sup> function	SU1_RXD0/SU1_SIN
						3 <sup>rd</sup> function	—
						4 <sup>th</sup> function	—
						5 <sup>th</sup> function	FTM2P
31	33	41	41	P22 / (I/O)	General I/O pin	6 <sup>th</sup> function	OUTLSCLK
						7 <sup>th</sup> function	—
						8 <sup>th</sup> function	AIN2
						2 <sup>nd</sup> function	SU1_TXD0/SU1_SOUT
						3 <sup>rd</sup> function	SU1_TXD1
						4 <sup>th</sup> function	I2CM0_SDA
32	34	42	42	P23 / EXI5 / EXTRG5 / (I/O)	General I/O pin External interrupt Functional timer external trigger	5 <sup>th</sup> function	FTM2N
						6 <sup>th</sup> function	OUTHCLK
						7 <sup>th</sup> function	—
						8 <sup>th</sup> function	AIN3
						2 <sup>nd</sup> function	SU1_SCLK
						3 <sup>rd</sup> function	—
32	34	42	42	P23 / EXI5 / EXTRG5 / (I/O)	General I/O pin External interrupt Functional timer external trigger	4 <sup>th</sup> function	I2CM0_SCL
						5 <sup>th</sup> function	TMH2OUT
						6 <sup>th</sup> function	—
						7 <sup>th</sup> function	—
						8 <sup>th</sup> function	V <sub>REF</sub>

Table 3 Pin List (4/10)

48Pin No.	52Pin No.	64Pin No. (QFP)	64Pin No. (TQFP)	Pn name	Primary function	Shared function	
33	35	43	43	P24 / (I/O)	General I/O pin	2 <sup>nd</sup> function	SU1_RXD0/SU1_SIN
						3 <sup>rd</sup> function	—
						4 <sup>th</sup> function	—
						5 <sup>th</sup> function	—
						6 <sup>th</sup> function	—
						7 <sup>th</sup> function	—
8 <sup>th</sup> function	AIN4						
34	36	44	44	P25 / (I/O)	General I/O pin	2 <sup>nd</sup> function	SU1_TXD0/SU1_SOUT
						3 <sup>rd</sup> function	SU1_TXD1
						4 <sup>th</sup> function	—
						5 <sup>th</sup> function	—
						6 <sup>th</sup> function	—
						7 <sup>th</sup> function	—
8 <sup>th</sup> function	AIN5						
35	37	45	45	P26 / EXI6 / EXTRG6 / (I/O)	General I/O pin External interrupt Functional timer external trigger	2 <sup>nd</sup> function	SU1_RXD1
						3 <sup>rd</sup> function	SU1_RXD0
						4 <sup>th</sup> function	I2CU0_SDA
						5 <sup>th</sup> function	FTM3P
						6 <sup>th</sup> function	TBCOUT0
						7 <sup>th</sup> function	BZ0P
8 <sup>th</sup> function	AIN6						
36	38	46	46	P27 / EXI7 / EXTRG7 / (I/O)	General I/O pin External interrupt Functional timer external trigger	2 <sup>nd</sup> function	SU1_TXD1
						3 <sup>rd</sup> function	—
						4 <sup>th</sup> function	I2CU0_SCL
						5 <sup>th</sup> function	FTM3N
						6 <sup>th</sup> function	TBCOUT1
						7 <sup>th</sup> function	BZ0N
8 <sup>th</sup> function	AIN7						
37	41	51	51	P30 / (I/O)	General I/O pin	2 <sup>nd</sup> function	—
						3 <sup>rd</sup> function	—
						4 <sup>th</sup> function	—
						5 <sup>th</sup> function	—
						6 <sup>th</sup> function	—
						7 <sup>th</sup> function	—
8 <sup>th</sup> function	—						
38	42	52	52	P31 / (I/O)	General I/O pin	2 <sup>nd</sup> function	—
						3 <sup>rd</sup> function	—
						4 <sup>th</sup> function	—
						5 <sup>th</sup> function	—
						6 <sup>th</sup> function	TBCOUT0
						7 <sup>th</sup> function	TBCOUT1
8 <sup>th</sup> function	—						

Table 3 Pin List (5/10)

48Pin No.	52Pin No.	64Pin No. (QFP)	64Pin No. (TOPP).	Pn name	Primary function	Shared function	
39	43	53	53	P32 / (I/O)	General I/O pin	2 <sup>nd</sup> function	SU1_RXD1
						3 <sup>rd</sup> function	SU1_RXD0
						4 <sup>th</sup> function	—
						5 <sup>th</sup> function	—
						6 <sup>th</sup> function	—
						7 <sup>th</sup> function	—
						8 <sup>th</sup> function	—
						40	44
3 <sup>rd</sup> function	—						
4 <sup>th</sup> function	—						
5 <sup>th</sup> function	TMH3OUT						
6 <sup>th</sup> function	—						
7 <sup>th</sup> function	—						
8 <sup>th</sup> function	—						
—	—	49	49	P40 / (I/O)	General I/O pin		
						3 <sup>rd</sup> function	—
						4 <sup>th</sup> function	—
						5 <sup>th</sup> function	—
						6 <sup>th</sup> function	—
						7 <sup>th</sup> function	—
						8 <sup>th</sup> function	—
						—	40
3 <sup>rd</sup> function	—						
4 <sup>th</sup> function	—						
5 <sup>th</sup> function	—						
6 <sup>th</sup> function	—						
7 <sup>th</sup> function	—						
8 <sup>th</sup> function	—						
—	—	63	63	P42 / (I/O)	General I/O pin		
						3 <sup>rd</sup> function	—
						4 <sup>th</sup> function	—
						5 <sup>th</sup> function	—
						6 <sup>th</sup> function	—
						7 <sup>th</sup> function	—
						8 <sup>th</sup> function	—
						48	52
3 <sup>rd</sup> function	—						
4 <sup>th</sup> function	—						
5 <sup>th</sup> function	—						
6 <sup>th</sup> function	TBCOUT0						
7 <sup>th</sup> function	TBCOUT1						
8 <sup>th</sup> function	AIN10						

Table 3 Pin List (6/10)

48Pin No.	52Pin No.	64Pin No. (QFP)	64Pin No. (TOFP)	Pn name	Primary function	Shared function	
						2 <sup>nd</sup> function	—
—	—	9	9	P44 (I/O)	General I/O pin	3 <sup>rd</sup> function	—
						4 <sup>th</sup> function	—
						5 <sup>th</sup> function	—
						6 <sup>th</sup> function	—
						7 <sup>th</sup> function	—
						8 <sup>th</sup> function	—
						2 <sup>nd</sup> function	—
						3 <sup>rd</sup> function	—
—	—	10	10	P45 (I/O)	General I/O pin	4 <sup>th</sup> function	—
						5 <sup>th</sup> function	—
						6 <sup>th</sup> function	—
						7 <sup>th</sup> function	—
						8 <sup>th</sup> function	—
						2 <sup>nd</sup> function	—
						3 <sup>rd</sup> function	—
						4 <sup>th</sup> function	—
—	—	13	13	P46 (I/O)	General I/O pin	5 <sup>th</sup> function	—
						6 <sup>th</sup> function	—
						7 <sup>th</sup> function	—
						8 <sup>th</sup> function	—
						2 <sup>nd</sup> function	—
						3 <sup>rd</sup> function	—
						4 <sup>th</sup> function	—
						5 <sup>th</sup> function	—
—	11	14	14	P47 (I/O)	General I/O pin	6 <sup>th</sup> function	—
						7 <sup>th</sup> function	—
						8 <sup>th</sup> function	—
						2 <sup>nd</sup> function	—
						3 <sup>rd</sup> function	—
						4 <sup>th</sup> function	—
						5 <sup>th</sup> function	—
						6 <sup>th</sup> function	—
24	25	29	29	P50 / (I/O)	General I/O pin	7 <sup>th</sup> function	—
						8 <sup>th</sup> function	—
						2 <sup>nd</sup> function	—
						3 <sup>rd</sup> function	—
						4 <sup>th</sup> function	—
						5 <sup>th</sup> function	—
						6 <sup>th</sup> function	—
						7 <sup>th</sup> function	—
—	26	30	30	P51 / (I/O)	General I/O pin	8 <sup>th</sup> function	—
						2 <sup>nd</sup> function	—
						3 <sup>rd</sup> function	—
						4 <sup>th</sup> function	—
						5 <sup>th</sup> function	—
						6 <sup>th</sup> function	—
						7 <sup>th</sup> function	—
						8 <sup>th</sup> function	—

Table 3 Pin List (7/10)

48Pin No.	52Pin No.	64Pin No. (QFP)	64Pin No. (TQFP)	Pn name	Primary function	Shared function	
						2 <sup>nd</sup> function	—
—	—	31	31	P52 / (I/O)	General I/O pin	2 <sup>nd</sup> function	—
						3 <sup>rd</sup> function	—
						4 <sup>th</sup> function	—
						5 <sup>th</sup> function	—
						6 <sup>th</sup> function	—
						7 <sup>th</sup> function	—
						8 <sup>th</sup> function	—
						—	—
3 <sup>rd</sup> function	—						
4 <sup>th</sup> function	—						
5 <sup>th</sup> function	—						
6 <sup>th</sup> function	—						
7 <sup>th</sup> function	—						
8 <sup>th</sup> function	—						
—	—	33	33	P54 / (I/O)	General I/O pin		
						3 <sup>rd</sup> function	—
						4 <sup>th</sup> function	—
						5 <sup>th</sup> function	—
						6 <sup>th</sup> function	—
						7 <sup>th</sup> function	—
						8 <sup>th</sup> function	—
						—	—
3 <sup>rd</sup> function	—						
4 <sup>th</sup> function	—						
5 <sup>th</sup> function	—						
6 <sup>th</sup> function	—						
7 <sup>th</sup> function	—						
8 <sup>th</sup> function	—						
—	39	47	47	P56 / (I/O)	General I/O pin		
						3 <sup>rd</sup> function	—
						4 <sup>th</sup> function	—
						5 <sup>th</sup> function	—
						6 <sup>th</sup> function	—
						7 <sup>th</sup> function	—
						8 <sup>th</sup> function	—
						—	—
3 <sup>rd</sup> function	—						
4 <sup>th</sup> function	—						
5 <sup>th</sup> function	—						
6 <sup>th</sup> function	—						
7 <sup>th</sup> function	—						
8 <sup>th</sup> function	—						

Table 3 Pin List (8/10)

48Pin No.	52Pin No.	64Pin No. (QFP)	64Pin No. (TOFP)	Pn name	Primary function	Shared function	
41	45	55	55	P60 / (I/O)	General I/O pin	2 <sup>nd</sup> function	—
						3 <sup>rd</sup> function	—
						4 <sup>th</sup> function	I2CM1_SCL
						5 <sup>th</sup> function	—
						6 <sup>th</sup> function	—
						7 <sup>th</sup> function	—
						8 <sup>th</sup> function	—
42	46	56	56	P61 / (I/O)	General I/O pin	2 <sup>nd</sup> function	—
						3 <sup>rd</sup> function	—
						4 <sup>th</sup> function	I2CM1_SDA
						5 <sup>th</sup> function	—
						6 <sup>th</sup> function	—
						7 <sup>th</sup> function	—
						8 <sup>th</sup> function	—
43	47	57	57	P62 / (I/O)	General I/O pin	2 <sup>nd</sup> function	—
						3 <sup>rd</sup> function	—
						4 <sup>th</sup> function	—
						5 <sup>th</sup> function	FTM4N
						6 <sup>th</sup> function	—
						7 <sup>th</sup> function	CMP1P
						8 <sup>th</sup> function	—
44	48	58	58	P63 / (I/O)	General I/O pin	2 <sup>nd</sup> function	—
						3 <sup>rd</sup> function	—
						4 <sup>th</sup> function	—
						5 <sup>th</sup> function	FTM4P
						6 <sup>th</sup> function	—
						7 <sup>th</sup> function	CMP1M
						8 <sup>th</sup> function	—
45	49	59	59	P64 / (I/O)	General I/O pin	2 <sup>nd</sup> function	—
						3 <sup>rd</sup> function	—
						4 <sup>th</sup> function	—
						5 <sup>th</sup> function	FTM5P
						6 <sup>th</sup> function	—
						7 <sup>th</sup> function	—
						8 <sup>th</sup> function	—
46	50	60	60	P65 / (I/O)	General I/O pin	2 <sup>nd</sup> function	—
						3 <sup>rd</sup> function	—
						4 <sup>th</sup> function	—
						5 <sup>th</sup> function	FTM5N
						6 <sup>th</sup> function	—
						7 <sup>th</sup> function	—
						8 <sup>th</sup> function	AIN8

Table 3 Pin List (9/10)

48Pin No.	52Pin No.	64Pin No. (QFP)	64Pin No. (TOFP)	Pn name	Primary function	Shared function	
						2 <sup>nd</sup> function	—
47	51	61	61	P66 / (I/O)	General I/O pin	2 <sup>nd</sup> function	—
						3 <sup>rd</sup> function	—
						4 <sup>th</sup> function	—
						5 <sup>th</sup> function	—
						6 <sup>th</sup> function	—
						7 <sup>th</sup> function	—
						8 <sup>th</sup> function	AIN9
—	—	62	62	P67 / (I/O)	General I/O pin	2 <sup>nd</sup> function	—
						3 <sup>rd</sup> function	—
						4 <sup>th</sup> function	—
						5 <sup>th</sup> function	—
						6 <sup>th</sup> function	—
						7 <sup>th</sup> function	—
						8 <sup>th</sup> function	—
—	—	20	20	P70 (I/O)	General I/O pin	2 <sup>nd</sup> function	—
						3 <sup>rd</sup> function	—
						4 <sup>th</sup> function	—
						5 <sup>th</sup> function	—
						6 <sup>th</sup> function	—
						7 <sup>th</sup> function	—
						8 <sup>th</sup> function	—
15	16	19	19	P71 (I/O)	General I/O pin	2 <sup>nd</sup> function	—
						3 <sup>rd</sup> function	—
						4 <sup>th</sup> function	—
						5 <sup>th</sup> function	—
						6 <sup>th</sup> function	—
						7 <sup>th</sup> function	—
						8 <sup>th</sup> function	—
14	15	18	18	P72 (I/O)	General I/O pin	2 <sup>nd</sup> function	—
						3 <sup>rd</sup> function	—
						4 <sup>th</sup> function	—
						5 <sup>th</sup> function	—
						6 <sup>th</sup> function	—
						7 <sup>th</sup> function	—
						8 <sup>th</sup> function	—
13	14	17	17	P73 (I/O)	General I/O pin	2 <sup>nd</sup> function	—
						3 <sup>rd</sup> function	—
						4 <sup>th</sup> function	—
						5 <sup>th</sup> function	—
						6 <sup>th</sup> function	—
						7 <sup>th</sup> function	—
						8 <sup>th</sup> function	—

Table 3 Pin List (10/10)

48Pin No.	52Pin No.	64Pin No. (QFP)	64Pin No. (TQFP)	Pn name	Primary function	Shared function	
						2 <sup>nd</sup> function	—
12	13	16	16	P74 (I/O)	General I/O pin	3 <sup>rd</sup> function	—
						4 <sup>th</sup> function	—
						5 <sup>th</sup> function	—
						6 <sup>th</sup> function	—
						7 <sup>th</sup> function	—
						8 <sup>th</sup> function	—
						2 <sup>nd</sup> function	—
11	12	15	15	P75 (I/O)	General I/O pin	3 <sup>rd</sup> function	—
						4 <sup>th</sup> function	—
						5 <sup>th</sup> function	—
						6 <sup>th</sup> function	—
						7 <sup>th</sup> function	—
						8 <sup>th</sup> function	—
						2 <sup>nd</sup> function	—

PIN DESCRIPTION

Table 4 Pin Description (1/4)

Function	Signal name	Pin name	I/O	Description	Logic
Power	—	V <sub>SS</sub>	—	Negative power supply pin (-)	—
	—	V <sub>DD</sub>	—	Positive power supply pin (+). Connect a capacitor C <sub>V</sub> (1μF) between this pin and V <sub>SS</sub> .	—
	—	V <sub>DDL</sub>	—	Power supply pin for internal logic (internal regulator's output). Connect a capacitor C <sub>V</sub> (1μF) between this pin and V <sub>SS</sub> .	—
Test	TEST0	P00	I/O	Input pin for testing. Also, used for on-chip debug interface or ISP function. P00 is initialized as pull-up input mode by the system reset (not high-impedance mode).	Positive
System	V <sub>REF</sub>	P23	—	Reference voltage output. An internal reference voltage in the SA type A/D converter block can be externally used for a reference. The pin is shared with the SA type A/D converter external reference voltage input.	—
	RESET_N	RESET_N	I	Input for reset. Asserting "L" level to this pin enters the MCU into system reset mode and internal circuits are initialized, then releasing it to "H" level make CPU start running the program. Used for on-chip debug interface or ISP function. Internal pull-up resistor is not installed.	Negative
	XT0	XT0	I	Low speed crystal oscillation pins Conenct 32.768kHz crystal resonator and have capacitors between the pin and V <sub>SS</sub> .	—
	XT1	XT1	O		—
	OUTLSCLK	P02 P21	O	Low-speed clock output.	—
	OUTHCLK	P03 P22	O	Low-speed clock output.	—
General input port (GPI)	PI00, PI01	XT0, XT1	I	General Input port Not available to use as general inputs when using the crystal resonator.	Positive
General port (GPIO)	P00	P00	I/O	General I/O port - High-impedance - Input with Pull-UP (initial value) - Input without Pull-UP - CMOS output - N-channel open drain output P00 is only initialized as pulled-up input and other ports are initialized as high-impedence Not available to use as I/O pin when using for on-chip debug interface or ISP function.	Positive
	P01 - P07	P01 - P07	I/O	General I/O port - High-impedance (initial value) - Input with Pull-UP - Input without Pull-UP - CMOS output - N-channel open drain output	Positive
	P10 - P17	P10 - P17			
	P20 - P27	P20 - P27			
	P30 - P33	P30 - P33			
	P40 - P47	P40 - P47			
	P50 - P57	P50 - P57			
	P60 - P67	P60 - P67			
P70 - P75	P70 - P75				

Table 4 Pin Description (2/4)

Function	Signal name	Pin name	I/O	Description	Logic
UART	SU0_TXD0	P03	O	Serial communication unit0/UART0 data output pin.	Positive
		P13			
	SU0_RXD0	P02	I	Serial communication unit0/UART0 data input pin.	Positive
		P07			
		P12			
		P17			
	SU0_TXD1	P03	O	Serial communication unit0/UART1 data output pin.	Positive
		P10			
		P13			
		P20			
	SU0_RXD1	P07	I	Serial communication unit0/UART1 data input pin.	Positive
		P17			
	SU1_TXD0	P22	O	Serial communication unit1/UART0 data output pin	Positive
		P25			
SU1_RXD0	P21	I	Serial communication unit1/UART0 data input pin.	Positive	
	P24				
	P26				
	P32				
SU1_TXD1	P22	O	Serial communication unit1/UART1 data output pin.	Positive	
	P25				
	P27				
	P33				
SU1_RXD1	P26	I	Serial communication unit1/UART1 data input pin.	Positive	
	P32				
Synchronous Serial Port	SU0_SIN	P02	I	Serial communication unit0/Synchronous serial data input pin.	Positive
		P12			
	SU0_SCK	P04	I/O	Serial communication unit0/Synchronous serial clock I/O pin.	Positive
		P11			
	SU0_SOUT	P03	O	Serial communication unit0/Synchronous serial data output pin.	Positive
		P13			
SU1_SIN	P21	I	Serial communication unit1/Synchronous serial data input pin.	Positive	
	P24				
SU1_SCK	P16	I/O	Serial communication unit1/Synchronous serial clock I/O pin.	Positive	
	P23				
SU1_SOUT	P22	O	Serial communication unit1/Synchronous serial data output pin.	Positive	
	P25				
I <sup>2</sup> C Bus	I2CU0_SDA	P03	I/O	I <sup>2</sup> C Unit0 (Master and Salve) Data I/O pin / N-ch open drain. Connect a pull-up resistor externally.	Positive
		P15			
		P26			
	I2CU0_SCL	P04	I/O	I <sup>2</sup> C Unit0 (Master and Salve) Clock I/O pin / N-ch open drain. Connect a pull-up resistor externally.	Positive
		P16			
		P27			
I2CM0_SDA	P06	I/O	I <sup>2</sup> C Master0 Data I/O pin / N-ch open drain. Connect a pull-up resistor externally.	Positive	
	P22				
I2CM0_SCL	P07	I/O	I <sup>2</sup> C Master0 Clock I/O pin / N-ch open drain. Connect a pull-up resistor externally.	Positive	
	P23				
I2CM1_SDA	P61	I/O	I <sup>2</sup> C Master1 Data I/O pin / N-ch open drain. Connect a pull-up resistor externally.	Positive	
I2CM1_SCL	P60	I/O	I <sup>2</sup> C Master1 Clock I/O pin / N-ch open drain. Connect a pull-up resistor externally.	Positive	

Table 4 Pin Description (3/4)

Function	Signal name	Pin name	I/O	Description	Logic	
Functional Timer (FTM)	FTM0P	P02	O	Functional Timer0 output.	Positive	
	FTM0N	P03	O	Functional Timer0 output.	Negative	
	FTM1P	P17	O	Functional Timer1 output.	Positive	
	FTM1N	P20	O	Functional Timer1 output.	Negative	
	FTM2P	P21	O	Functional Timer2 output.	Positive	
	FTM2N	P22	O	Functional Timer2 output.	Negative	
	FTM3P	P26	O	Functional Timer3 output.	Positive	
	FTM3N	P27	O	Functional Timer3 output.	Negative	
	FTM4P	P63	O	Functional Timer4 output.	Positive	
	FTM4N	P62	O	Functional Timer4 output.	Negative	
	FTM5P	P64	O	Functional Timer5 output.	Positive	
	FTM5N	P65	O	Functional Timer5 output.	Negative	
		EXTRG0	P02	I	Functional Timer0-5 event trigger input pin.	—
		EXTRG1	P03	I	Functional Timer0-5 event trigger input pin.	—
		EXTRG2	P04	I	Functional Timer0-5 event trigger input pin.	—
		EXTRG3	P17	I	Functional Timer0-5 event trigger input pin.	—
		EXTRG4	P21	I	Functional Timer0-5 event trigger input pin.	—
	EXTRG5	P23	I	Functional Timer0-5 event trigger input pin.	—	
	EXTRG6	P26	I	Functional Timer0-5 event trigger input pin.	—	
	EXTRG7	P27	I	Functional Timer0-5 event trigger input pin.	—	
16bit General Timer	TMH0OUT	P04	O	16bit General Timer 0 output pin	Positive	
	TMH1OUT	P13	O	16bit General Timer 1 output pin	Positive	
	TMH2OUT	P23	O	16bit General Timer 2 output pin	Positive	
	TMH3OUT	P13 P33	O	16bit General Timer 3 output pin	Positive	
	TMH4OUT	P12	O	16bit General Timer 4 output pin	Positive	
	TMH5OUT	P16	O	16bit General Timer 5 output pin	Positive	
Time Base Counter (TBC)	TBCOUT0	P01	O	Frequency adjustment clock output pin	Positive	
		P17				
		P26				
		P31				
	TBCOUT1	P01	O	Time Base Counter 1Hz/2Hz output pin	Positive	
		P20				
		P27				
		P31				
Buzzer	BZ0P	P17	O	Buzzer output (positive phase)	Positive	
		P26				
	BZ0N	P20	O	Buzzer output (negative phase)	Negative	
		P27				

Table 4 Pin Description (4/4)

Function	Signal name	Pin name	I/O	Description	Logic
External Interrupt	EXI0	P02	I	GPIO maskable external interrupt pin	—
	EXI1	P03	I	GPIO maskable external interrupt pin	—
	EXI2	P04	I	GPIO maskable external interrupt pin	—
	EXI3	P17	I	GPIO maskable external interrupt pin	—
	EXI4	P21	I	GPIO maskable external interrupt pin	—
	EXI5	P23	I	GPIO maskable external interrupt pin	—
	EXI6	P26	I	GPIO maskable external interrupt pin	—
Successive approximation type A/D converter	V <sub>REF1</sub>	P23	—	SA type A/D converter external reference voltage input. The voltage provided to the pin is used as the reference voltage for the A/D conversion.	—
	AIN0	P17	I	SA type A/D converter channel 0 input pin	—
	AIN1	P20	I	SA type A/D converter channel 1 input pin	—
	AIN2	P21	I	SA type A/D converter channel 2 input pin	—
	AIN3	P22	I	SA type A/D converter channel 3 input pin	—
	AIN4	P24	I	SA type A/D converter channel 4 input pin	—
	AIN5	P25	I	SA type A/D converter channel 5 input pin	—
	AIN6	P26	I	SA type A/D converter channel 6 input pin	—
	AIN7	P27	I	SA type A/D converter channel 7 input pin	—
	AIN8	P65	I	SA type A/D converter channel 8 input pin	—
	AIN9	P66	I	SA type A/D converter channel 9 input pin	—
	AIN10	P43	I	SA type A/D converter channel 10 input pin	—
Analog comparator	AIN11	P03	I	SA type A/D converter channel 11 input pin	—
	CMP0P	P03	I	Comparator input 0 (noninverting input)	—
	CMP0M	P02	I	Comparator input 0 (inverting input)	—
	CMP1P	P62	I	Comparator input 1 (noninverting input)	—
D/A converter	CMP1M	P63	I	Comparator input 1 (inverting input)	—
	DACOUT	P01	O	D/A converter output pin	—

## TERMINATION OF UNUSED PINS

Table 5 Termination of unused pins

Pin	Recommended pin termination
RESET_N	Connect to $V_{DD}$ through a resistor
P00/TEST0	Open the pin with the internal initial condition of pulled-up input mode.
XT0/PI00, XT1/PI01	Open the pins with the internal initial condition of Hi-impedance mode.
P01 to P07	
P10 to P17	
P20 to P27	
P30 to P33	
P40 to P47	
P50 to P57	
P60 to P67	
P70 to P75	

## Note:

For unused input ports or unused input/output ports, if an unstable middle level voltage is supplied to the corresponding pins which are configured as inputs without pull-up register or input/output mode, supply current may become excessively large. Therefore, it is recommended to configure those pins as either input mode with a pull-up resistor or output mode.

## ELECTRICAL CHARACTERISTICS

### Absolute Maximum Ratings

 (V<sub>SS</sub> = 0V)

Parameter	Symbol	Condition	Rating	Unit	
Power supply voltage 1	V <sub>DD</sub>	Ta = +25°C	-0.3 to +6.5	V	
Power supply voltage 2	V <sub>DDL</sub>	Ta = +25°C	-0.3 to +2.0	V	
Input voltage	V <sub>IN</sub>	Ta = +25°C	-0.3 to V <sub>DD</sub> +0.3* <sup>1</sup>	V	
Output voltage1	V <sub>OUT1</sub>	Ta = +25°C	-0.3 to V <sub>DD</sub> +0.3* <sup>1</sup>	V	
Output voltage2	V <sub>OUT2</sub>	Ta = +25°C	-0.3 to +6.5	V	
“H” level output current	I <sub>OUTH</sub>	Ta = +25°C	1pin	-40* <sup>2</sup>	mA
			Total	-150* <sup>2</sup>	
“L” level output current	I <sub>OUTL</sub>	Ta = +25°C	1pin	+40	mA
			Total	+150	
Power dissipation	PD	Ta = +25°C	1	W	
Storage temperature	T <sub>STG</sub>	—	-55 to +150	°C	

\*<sup>1</sup> 6.5V or lower

\*<sup>2</sup> The current flowing out the LSI through the pin is described in the negative number.

The applicable maximum current is the absolute value.

For example, -1mA means the maximum current 1mA flows out the LSI through the pin.

[Note] Use the product within absolute maximum ratings. The absolute maximum ratings are conditions which may physically deteriorate the quality of product.

### Recommended Operating Conditions

 (V<sub>SS</sub> = 0V)

Parameter	Symbol	Condition	Range	Unit
Operating temperature	T <sub>OP</sub>	—	-40 to ++105	°C
Operating voltage 1	V <sub>DD</sub>	—	1.6 to 5.5	V
Operating frequency (CPU)	f <sub>OP</sub>	V <sub>DD</sub> = 1.6 to 5.5V	30k to 4M	Hz
		V <sub>DD</sub> = 1.8 to 5.5V	30k to 25M	
V <sub>DDL</sub> pin external capacitance	C <sub>L</sub>	—	1.0 ±30%	μF

Maker	Part number	Frequency (kHz)	Load capacitance CL(pf)	Oscillation mode	Oscillation circuit parameter C <sub>DL</sub> (pf) * <sup>2,3</sup>	Oscillation circuit parameter C <sub>GL</sub> (pf) * <sup>2,3</sup>
Kyocera	ST3215SB* <sup>1</sup>	32.768	7	Standard	13	13
				Low power	12	12
			Touch	13	13	
				18	18	
SII	VT-200F* <sup>1</sup>		12.5	Standard	22	22
			9	Low power	16	16
Daishinku	DST1610A* <sup>1</sup>		12.5	Touch	22	22

\*<sup>1</sup> These crystal resonator support the operating temperature up to +85°C. Ask the crystal resonator makers for the product supports +105°C.

\*<sup>2</sup> These includes wiring and parasitic capacitance.

\*<sup>3</sup> These are reference data. Please optimize them on user system.

## Current Consumption

(V<sub>DD</sub>=1.6 to 5.5V, V<sub>SS</sub>=0V, Ta=-40 to +105°C, unless otherwise specified)

Parameter	Symbol	Condition	Min.	Typ.	Max.	Unit	Measuring circuit	
Supply current 0	IDD0	CPU is in STOP-D state. Low-speed RC1K/RC32K and PLL oscillation are stopped.	Ta = -40 to +85 °C	—	0.5	20	μA	1
			Ta = -40 to +105 °C	—	0.5	55		
Supply current 1	IDD1	CPU is in STOP state. Low-speed RC1K/RC32K and PLL oscillation are stopped.	Ta = -40 to +85 °C	—	0.65	22	μA	
			Ta = -40 to +105 °C	—	0.65	60		
Supply current 2-1	IDD2-1	Internal RC Oscillating. CPU is in HALT state (LTBC and WDT are operating <sup>*1</sup> ). PLL oscillation is stopped.	Ta = -40 to +85 °C	—	3.4	27	μA	
			Ta = -40 to +105 °C	—	3.4	67		
Supply current 2-2	IDD2-2	Low speed Crystal Oscillating. CPU is in HALT state (LTBC and WDT are operating <sup>*1</sup> ). PLL oscillation is stopped.	Ta = -40 to +85 °C	—	2.2	27	μA	
			Ta = -40 to +105 °C	—	2.2	67		
Supply current 3	IDD3	CPU: Running with 32kHz RC oscillation clock <sup>*1*2</sup> PLL oscillation is stopped.	Ta = -40 to +105 °C	—	14	76	μA	
Supply current 4	IDD4	CPU: Running with 16MHz PLL oscillating clock <sup>*2</sup> PLL 32MHz is oscillating. V <sub>DD</sub> =1.8~5.5V	Ta = -40 to +105 °C	—	5.0	6.2	mA	
Supply current 5	IDD5	CPU: Running with 24MHz PLL oscillating clock <sup>*2</sup> PLL 24MHz is oscillating. V <sub>DD</sub> =1.8~5.5V	Ta = -40 to +105 °C	—	7.3	8.5		

\*1 LTBC and WDT is operating, Significant bits of BLKCON0-3 and BRECON0-3 registers are all "1"

\*2 CPU running in wait mode

Low speed Crystal Oscillation

(V<sub>DD</sub>=1.6 to 5.5V, V<sub>SS</sub>=0V, Ta=-40 to +105°C, unless otherwise specified)

Parameter	Symbol	Condition	Range			Unit
			Min.	Typ.	Max.	
Crystal oscillation frequency *1 *2	f <sub>XTL</sub>	—	—	32.768	—	kHz
Crystal oscillation start time	T <sub>XTL</sub>	—	—	—	2	s

\*1: The oscillation frequency is determined by the oscillation circuit, crystal resonator and the external capacitance (C<sub>GL</sub>/C<sub>DL</sub>). As those parameters changes depending the crystal resonator, it requires evaluation on the actual PCB circuit for matching. Ask crystal resonator makers for matching and confirm the oscillation characteristics.

\*2: The quality of oscillation characteristics might be lost, depending on material of PCB, condition of wiring capacitance or parasitic capacitance on the external circuits. Note for designing the external circuit.

- Make the wires on the external circuit as short as possible.
- Place the crystal resonator and oscillation circuit as close to the MCU as possible and make the wires between the external capacitance and crystal resonator as short as possible.
- Ensure no signal line flowing big current runs near the oscillation circuit.
- Ensure no signal line runs under and near the oscillation circuit.
- Make ground of external capacitance the same as MCU ground VSS pin and connect them to the ground that has low variation of current and voltage.
- The quality of oscillation characteristics might be lost depending on operating environment due to moisture absorption of PCB and condensation of PCB surface, recommended to have measures such as covering the oscillation circuit with resin.

Low speed Crystal Oscillation external circuit example

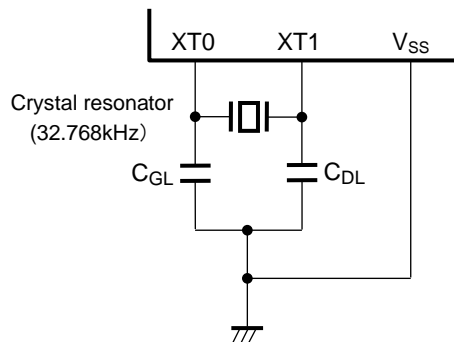

External Clock Input

(V<sub>DD</sub>=1.6 to 5.5V, V<sub>SS</sub>=0V, Ta=-40 to +105°C, unless otherwise specified)

Parameter	Symbol	Condition	Range			Unit
			Min.	Typ.	Max.	
Input Frequency	f <sub>EXCK</sub>	—	Typ. -1.0%	32.768	Typ. +1.0%	kHz
Input pulse width	t <sub>EXCKW</sub>	—	1/f <sub>EXCK</sub> x 0.4		1/f <sub>EXCK</sub> x 0.6	s

## On-chip Oscillator

(V<sub>DD</sub>=1.6 to 5.5V, V<sub>SS</sub>=0V, T<sub>a</sub>=-40 to +105°C, unless otherwise specified)

Parameter	Symbol	Condition	Min.	Typ.	Max.	Unit	Measuring circuit
Low-speed RC oscillator frequency accuracy 1	f <sub>RCL1</sub>	T <sub>a</sub> = +25°C V <sub>DD</sub> = 1.8 to 5.5V Without software adjustment *1	Typ -1.0%	32.768	Typ +1.0%	kHz	1
		T <sub>a</sub> = -40 to +85°C V <sub>DD</sub> = 1.8 to 5.5V Without software adjustment *1	Typ -2.5%	32.768	Typ +2.5%		
		T <sub>a</sub> = -40 to +105°C V <sub>DD</sub> = 1.8 to 5.5V Without software adjustment *1	Typ -3.0%	32.768	Typ +3.0%		
		V <sub>DD</sub> = 1.6 to 1.8V Without software adjustment *1	Typ -3.5%	32.768	Typ -3.5%		
Low-speed RC oscillator frequency accuracy 2	f <sub>RCL2</sub>	T <sub>a</sub> = -40 to +85°C V <sub>DD</sub> = 1.8 to 5.5V With software adjustment *1	Typ -1.0%	32.768	Typ +1.0%		
		T <sub>a</sub> = -40 to +105°C V <sub>DD</sub> = 1.8 to 5.5V With software adjustment *1	Typ -1.5%	32.768	Typ +1.5%		
PLL oscillation frequency accuracy 1	f <sub>PLL1</sub>	T <sub>a</sub> = -40 to +85°C V <sub>DD</sub> = 1.8 to 5.5V Without software adjustment *1	Typ -2.5%	16/24/32	Typ +2.5%	MHz	
		T <sub>a</sub> = -40 to +105°C V <sub>DD</sub> = 1.8 to 5.5V Without software adjustment *1	Typ -3.0%	16/24/32	Typ +3.0%		
		V <sub>DD</sub> = 1.6 to 1.8V Without software adjustment *1	Typ -3.5%	16/24/32	Typ +3.5%		
PLL oscillation frequency accuracy 2	f <sub>PLL2</sub>	T <sub>a</sub> = -40 to +85°C V <sub>DD</sub> = 1.8 to 5.5V With software adjustment *1	Typ -1.0%	16/24/32	Typ +1.0%		
		T <sub>a</sub> = -40 to +105°C V <sub>DD</sub> = 1.8 to 5.5V With software adjustment *1	Typ -1.5%	16/24/32	Typ +1.5%		
PLL oscillation start time	T <sub>PLL</sub>	V <sub>DD</sub> = 1.6 to 5.5V	—	—	2	ms	
1kHz Low-speed RC oscillator (for WDT) frequency accuracy	f <sub>RC1K</sub>	T <sub>a</sub> = -40 to +105°C V <sub>DD</sub> = 1.6 to 5.5V	0.5	1	2.5	kHz	

\*1 Adjust the frequency by using temperature sensor in ADC and a Specific Function Register (LRCADJ register)

## Input / Output pin 1

(V<sub>DD</sub>=1.6 to 5.5V, V<sub>SS</sub>=0V, Ta=-40 to +105°C, unless otherwise specified)

Parameter	Symbol	Condition	Min.	Typ.	Max.	Unit	Measuring circuit
Output voltage1 "H"/"L" level (P00-P07) (P10-P17) (P20-P27) (P30-P33) (P40-P47) (P50-P57) (P60-P67) (P70-P75)	VOH1	I <sub>OH1</sub> =-10mA V <sub>DD</sub> ≥4.5V	V <sub>DD</sub> -1.5	—	—	V	2
		I <sub>OH1</sub> =-1mA V <sub>DD</sub> ≥1.6V	V <sub>DD</sub> -0.5	—	—		
	VOL1	I <sub>OL1</sub> =+10mA V <sub>DD</sub> ≥4.5V	—	—	1.5		
		I <sub>OL1</sub> =+1mA V <sub>DD</sub> ≥1.6V	—	—	0.5		
Output voltage2 "L" level (P01-P07) (P10-P17) (P20-P27) (P30-P33) (P40-P47) (P50-P57) (P60-P67) (P70-P75)	VOL2	When Nch open drain output mode is selected	I <sub>OL2</sub> =+15mA V <sub>DD</sub> ≥4.5V	—	—	0.7	
			I <sub>OL2</sub> =+8mA V <sub>DD</sub> ≥3.0V	—	—	0.5	
			I <sub>OL2</sub> =+3mA V <sub>DD</sub> ≥2.0V	—	—	0.4	
			I <sub>OL2</sub> =+2mA 2.0V>V <sub>DD</sub> ≥1.6V	—	—	0.4	

Input / Output pin 2

(V<sub>DD</sub>=1.6 to 5.5V, V<sub>SS</sub>=0V, Ta=-40 to +105°C, unless otherwise specified)

Parameter	Symbol	Condition	Min.	Typ.	Max.	Unit	Measuring circuit	
“H” level output current1 *1*4	IOH1	1pin	V <sub>DD</sub> ≥4.5V	-10*3*5	—	—	mA	3
			V <sub>DD</sub> ≥1.6V	-1*3*5	—	—		
		Total of P00~P07, P10~P13, P44~P47, P50~P53, P70~P75 (duty≤50%)	V <sub>DD</sub> ≥4.5V	-90*5	—	—		
			V <sub>DD</sub> ≥1.6V	-20*5	—	—		
		Total of P14~P17, P20~P27, P30~P33, P40~P43, P54~P57 P60~P67 (duty≤50%)	V <sub>DD</sub> ≥4.5V	-90*5	—	—		
			V <sub>DD</sub> ≥1.6V	-20*5	—	—		
		All pin total (duty≤50%)	V <sub>DD</sub> ≥4.5V	-180*5	—	—		
			V <sub>DD</sub> ≥1.6V	-40*5	—	—		
“L” level output current1 *2	IOL1	1pin (CMOS output mode)	V <sub>DD</sub> ≥4.5V	—	—	10*3	mA	3
			V <sub>DD</sub> ≥1.6V	—	—	1*3		
“L” level output current2 *2	IOL2	1pin (Nch open drain output mode)	V <sub>DD</sub> ≥4.5V	—	—	15*3	mA	3
			V <sub>DD</sub> ≥3.0V	—	—	8*3		
			V <sub>DD</sub> ≥2.0V	—	—	3*3		
			V <sub>DD</sub> ≥1.6V	—	—	2*3		
“L” level output current *2*4	IOL3	Total of P00~P07, P10~P13, P44~P47, P50~P53, P70~P75 (duty≤50% *6)	V <sub>DD</sub> ≥4.5V	—	—	90	mA	3
			V <sub>DD</sub> ≥3.0V	—	—	40		
			V <sub>DD</sub> ≥2.0V	—	—	15		
			2.0V>V <sub>DD</sub> ≥1.6V	—	—	10		
		Total of P14~P17, P20~P27, P30~P33, P40~P43, P54~P57 and P60~P67 (duty≤50% *6)	V <sub>DD</sub> ≥4.5V	—	—	90		
			V <sub>DD</sub> ≥3.0V	—	—	40		
			V <sub>DD</sub> ≥2.0V	—	—	15		
			2.0V>V <sub>DD</sub> ≥1.6V	—	—	10		
All pin total (duty≤50% *6)	V <sub>DD</sub> ≥4.5V	—	—	180				
	2.0V>V <sub>DD</sub> ≥1.6V	—	—	20				
Output leak (P00-P07) (P10-P17) (P20-P27) (P30-P33) (P40-P47) (P50-P57) (P60-P67) (P70-P75)	IOOH	VOH=V <sub>DD</sub> (High impedance mode)	—	—	+1	μA	3	
	IOOL	VOL=V <sub>SS</sub> (High impedance mode)	-1*5	—	—			

- \*1 Sink-out current from  $V_{DD}$  to the output pin, which can guarantee the device operation.
- \*2 Sink-in current from the output pin to  $V_{SS}$ , which can guarantee the device operation.
- \*3 Do not beyond total current.
- \*4 The total current is on the condition of Duty  $\leq 50\%$ (same applies to IOH1).  
When the duty  $> 50\%$  the total current is calculated by following formula.  
Total current =  $IOL3 \times 50/n$  (When the duty is n%)  
<For an example> When  $IOL3=100mA$  and  $n=80\%$ ,  
Total current =  $IOL3 \times 50/80 = 62.5mA$   
Current allowed per 1pin is independent of the duty and specified as IOL1 and IOL2.  
Do not apply current larger than Absolute Maximum Ratings.
- \*5 The current flowing out the LSI through the pin is described in the negative number.  
The applicable maximum current is the absolute value.  
For example,  $-1mA$  means the maximum current 1mA flows out the LSI through the pin.
- \*6 Nch open drain output mode

(V<sub>DD</sub>=1.6 to 5.5V, V<sub>SS</sub>=0V, Ta=-40 to +105°C, unless otherwise specified)

Parameter	Symbol	Condition	Min.	Typ.	Max.	Unit	Measuring circuit
Input current1 (RESET_N)	I <sub>IH1</sub>	V <sub>IH1</sub> =V <sub>DD</sub>	—	—	1	μA	4
	I <sub>IL1</sub>	V <sub>IL1</sub> =V <sub>SS</sub>	-1* <sup>1</sup>	—	—		
Input current2 (P00/TEST0)	I <sub>IL2</sub>	V <sub>IL2</sub> =V <sub>SS</sub> (pull-up mode)	-1500* <sup>1</sup>	-300* <sup>1</sup>	-20* <sup>1</sup>	kΩ	
	V/I <sub>IL2</sub>	V <sub>IL2</sub> =V <sub>SS</sub> (pull-up mode)	3.7	10	80	μA	
	I <sub>IH2Z</sub>	V <sub>IH2</sub> =V <sub>DD</sub> (High impedance mode)	—	—	1		
	I <sub>IL2Z</sub>	V <sub>IL2</sub> =V <sub>SS</sub> (High impedance mode)	-1* <sup>1</sup>	—	—		
Input current3 (P01-P07) (P10-P17) (P20-P27) (P30-P33) (P40-P47) (P50-P57) (P60-P67) (P70-P75)	I <sub>IL3</sub>	V <sub>IL3</sub> =V <sub>SS</sub> (pull-up mode)	-250* <sup>1</sup>	-30* <sup>1</sup>	-2* <sup>1</sup>	kΩ	
	V/I <sub>IL3</sub>	V <sub>IL3</sub> =V <sub>SS</sub> (pull-up mode)	22	100	800	μA	
	I <sub>IH3Z</sub>	V <sub>IH3</sub> =V <sub>DD</sub> (High impedance mode)	—	—	1		
	I <sub>IL3Z</sub>	V <sub>IL3</sub> =V <sub>SS</sub> (High impedance mode)	-1* <sup>1</sup>	—	—		
Input current4 (PI00-PI01)	I <sub>IH4</sub>	V <sub>IH4</sub> =V <sub>DD</sub>	—	—	1	μA	
	I <sub>IL4</sub>	V <sub>IL4</sub> =V <sub>SS</sub>	-1* <sup>1</sup>	—	—		
Input voltage1 (RESET_N) (P00/TEST0) (P01-P07) (P10-P17) (P20-P27) (P30-P33) (P40-P47) (P50-P57) (P60-P67) (P70-P75) (PI00~PI01)	V <sub>IH1</sub>	—	0.7 x V <sub>DD</sub>	—	V <sub>DD</sub>	V	5
	V <sub>IL1</sub>	—	0	—	0.3 x V <sub>DD</sub>		
Pin capacitance (RESET_N) (P00/TEST0) (P01-P07) (P10-P17) (P20-P27) (P30-P33) (P40-P47) (P50-P57) (P60-P67) (P70-P75) (PI00~PI01)	C <sub>PIN</sub>	f = 10kHz Ta = +25°C	—	—	10	pF	—

\*<sup>1</sup> The current flowing out the LSI through the pin is described in the negative number.

The applicable maximum current is the absolute value.

For example, -1mA means the maximum current 1mA flows out the LSI through the pin.

Synchronous Serial Port

Slave mode

( $V_{DD}=1.8$  to  $5.5V$ ,  $V_{SS}=0V$ ,  $T_a=-40$  to  $+105^{\circ}C$ , unless otherwise specified)

Parameter	Symbol	Condition	Min.	Typ.	Max.	Unit
SCK input cycle	$t_{SCYC}$	—	1 <sup>*2</sup>	—	—	$\mu s$
SCK input pulse width	$t_{SW}$	—	0.5 <sup>*3</sup>	—	—	$\mu s$
SOUT output delay time	$t_{SD}$	$V_{DD}=2.4$ to $5.5V$	—	—	$100+$ $HCLK^{*1} \times 3$	ns
		$V_{DD}=1.8$ to $5.5V$	—	—	$200+$ $HCLK^{*1} \times 3$	ns
SIN input setup time	$t_{SS}$	—	$HCLK^{*1}$ $\times 1$	—	—	ns
SIN input hold time	$t_{SH}$	—	$80+$ $HCLK^{*1} \times 3$	—	—	ns

\*1 Cycle of high speed clock

\*2 Need input cycles of HSLCK x8 or longer

\*3 Need input cycles of HSLCK x4 or longer

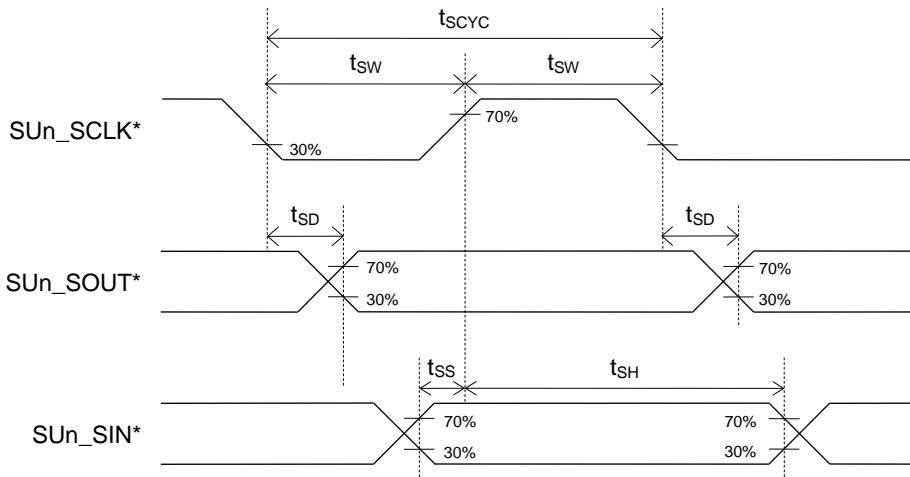

\* 2<sup>nd</sup> to 8<sup>th</sup> function of port, n=0~1

Master mode

( $V_{DD}=1.8$  to  $5.5V$ ,  $V_{SS}=0V$ ,  $T_a=-40$  to  $+105^{\circ}C$ , unless otherwise specified)

Parameter	Symbol	Condition	Min.	Typ.	Max.	Unit
SCK output cycle	$t_{SCYC}$	—	—	$SCLK^{*1}$	—	ns
SCK output pulse width	$t_{SW}$	—	$SCLK^{*1} \times 0.4$	$SCLK^{*1} \times 0.5$	$SCLK^{*1} \times 0.6$	ns
SOUT output delay time	$t_{SD}$	$V_{DD}=2.4$ to $5.5V$	—	—	100	ns
		$V_{DD}=1.8$ to $5.5V$	—	—	160	ns
SIN input setup time	$t_{SS}$	$V_{DD}=2.4$ to $5.5V$	120	—	—	ns
		$V_{DD}=1.8$ to $5.5V$	180	—	—	ns
SIN input hold time	$t_{SH}$	$V_{DD}=2.4$ to $5.5V$	80	—	—	ns
		$V_{DD}=1.8$ to $5.5V$	100	—	—	ns

\*1 Clock cycle selected by bit12~8(SnCK4~0) of the serial port n mode register (SIOOnMOD)  
 $V_{DD} \geq 2.4V$ : min250ns ,  $V_{DD} \geq 1.8V$ : min500ns

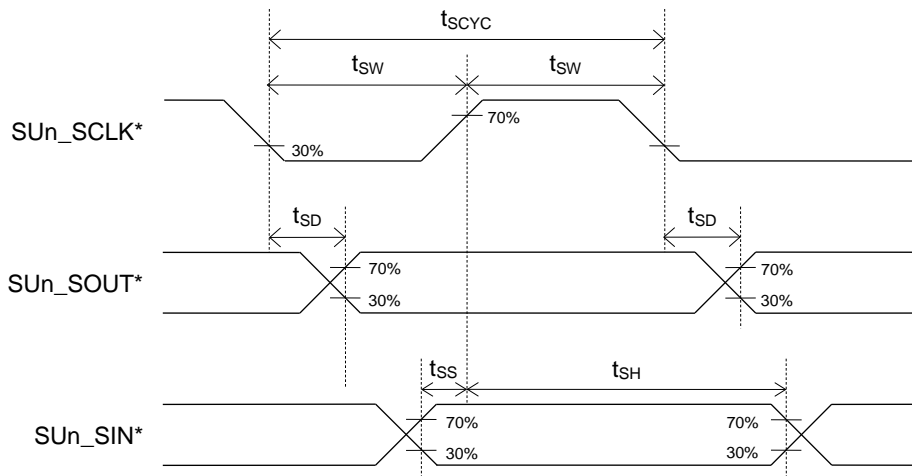

\* 2<sup>nd</sup> to 8<sup>th</sup> function of port, n=0~1

I<sup>2</sup>C Bus Interface

Standard Mode 100kHz

(V<sub>DD</sub>=1.8 to 5.5V, V<sub>SS</sub>=0V, Ta=-40 to +105°C, unless otherwise specified)

Parameter	Symbol	Condition	Min.	Typ.	Max.	Unit
SCL clock frequency	f <sub>SCL</sub>	—	0	—	100	kHz
SCL hold time (start/restart condition)	t <sub>HD:STA</sub>	—	4.0	—	—	μs
SCL "L" level time	t <sub>LOW</sub>	—	4.7	—	—	μs
SCL "H" level time	t <sub>HIGH</sub>	—	4.0	—	—	μs
SCL setup time (restart condition)	t <sub>SU:STA</sub>	—	4.7	—	—	μs
SDA hold time	t <sub>HD:DAT</sub>	—	0	—	—	μs
SDA setup time	t <sub>SU:DAT</sub>	—	0.25	—	—	μs
SDA setup time (stop condition)	t <sub>SU:STO</sub>	—	4.0	—	—	μs
Bus-free time	t <sub>BUF</sub>	—	4.7	—	—	μs

When using the I<sup>2</sup>C as the master, configure the I<sup>2</sup>C master n mode register(I2MnMOD) and I<sup>2</sup>C bus 0 mode register (master side, I2UM0MOD) so that meet these specifications.

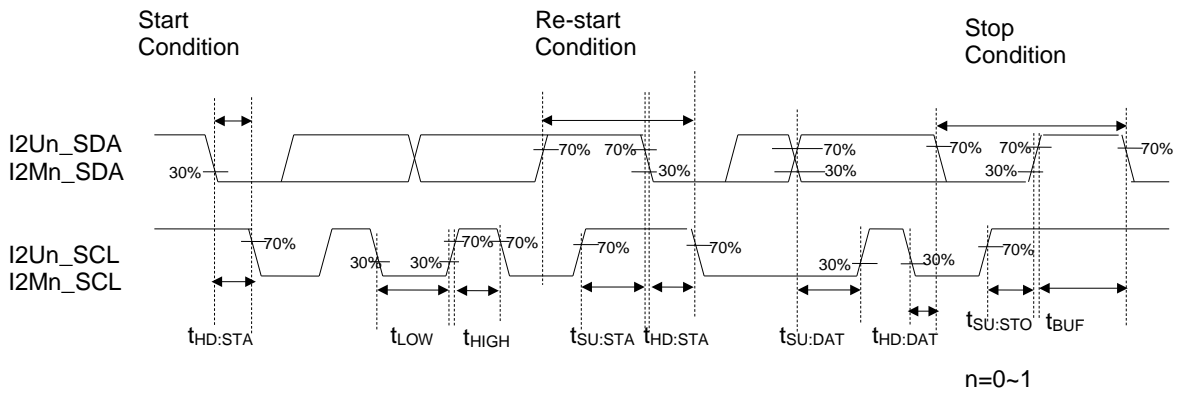

Fast Mode 400kHz

( $V_{DD}=1.8$  to  $5.5V$ ,  $V_{SS}=0V$ ,  $T_a=-40$  to  $+105^{\circ}C$ , unless otherwise specified)

Parameter	Symbol	Condition	Min.	Typ.	Max.	Unit
SCL clock frequency	$f_{SCL}$	—	0	—	400	kHz
SCL hold time (start/restart condition)	$t_{HD:STA}$	—	0.6	—	—	$\mu s$
SCL "L" level time	$t_{LOW}$	—	1.3	—	—	$\mu s$
SCL "H" level time	$t_{HIGH}$	—	0.6	—	—	$\mu s$
SCL setup time (restart condition)	$t_{SU:STA}$	—	0.6	—	—	$\mu s$
SDA hold time	$t_{HD:DAT}$	—	0	—	—	$\mu s$
SDA setup time	$t_{SU:DAT}$	—	0.1	—	—	$\mu s$
SDA setup time (stop condition)	$t_{SU:STO}$	—	0.6	—	—	$\mu s$
Bus-free time	$t_{BUF}$	—	1.3	—	—	$\mu s$

When using the I<sup>2</sup>C as the master, configure the I<sup>2</sup>C master n mode register(I2MnMOD) and I<sup>2</sup>C bus 0 mode register (master side, I2UM0MOD) so that meet these specifications.

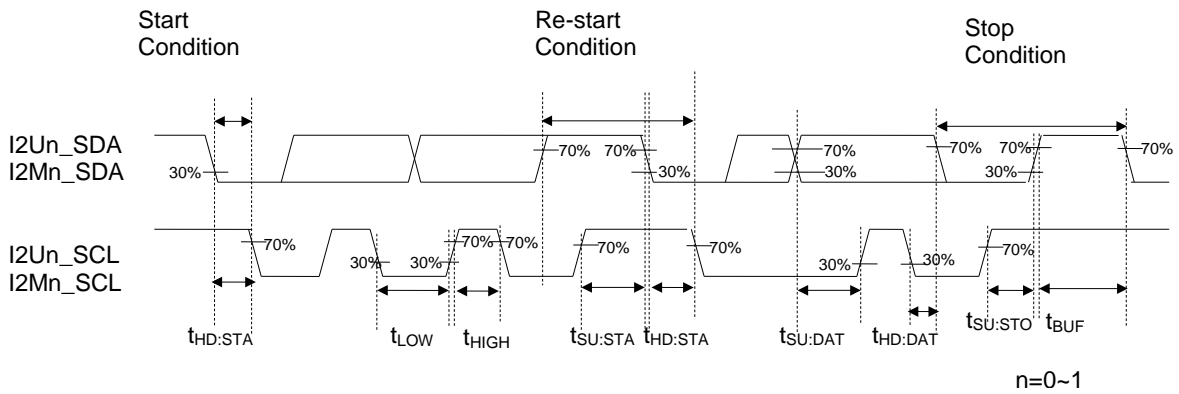

1Mbps Mode

( $V_{DD}=2.7$  to  $5.5V$ ,  $V_{SS}=0V$ ,  $T_a=-40$  to  $+105^{\circ}C$ , unless otherwise specified)

Parameter	Symbol	Condition	Min.	Typ.	Max.	Unit
SCL clock frequency	$f_{SCL}$	—	0	—	1000	kHz
SCL hold time (start/restart condition)	$t_{HD:STA}$	—	0.26	—	—	$\mu s$
SCL "L" level time	$t_{LOW}$	—	0.5	—	—	$\mu s$
SCL "H" level time	$t_{HIGH}$	—	0.26	—	—	$\mu s$
SCL setup time (restart condition)	$t_{SU:STA}$	—	0.26	—	—	$\mu s$
SDA hold time	$t_{HD:DAT}$	—	0	—	—	$\mu s$
SDA setup time	$t_{SU:DAT}$	—	0.1	—	—	$\mu s$
SDA setup time (stop condition)	$t_{SU:STO}$	—	0.26	—	—	$\mu s$
Bus-free time	$t_{BUF}$	—	0.5	—	—	$\mu s$

When using the I<sup>2</sup>C as the master, configure the I<sup>2</sup>C master n mode register(I2MnMOD) and I<sup>2</sup>C bus 0 mode register (master side, I2UM0MOD) so that meet these specifications.

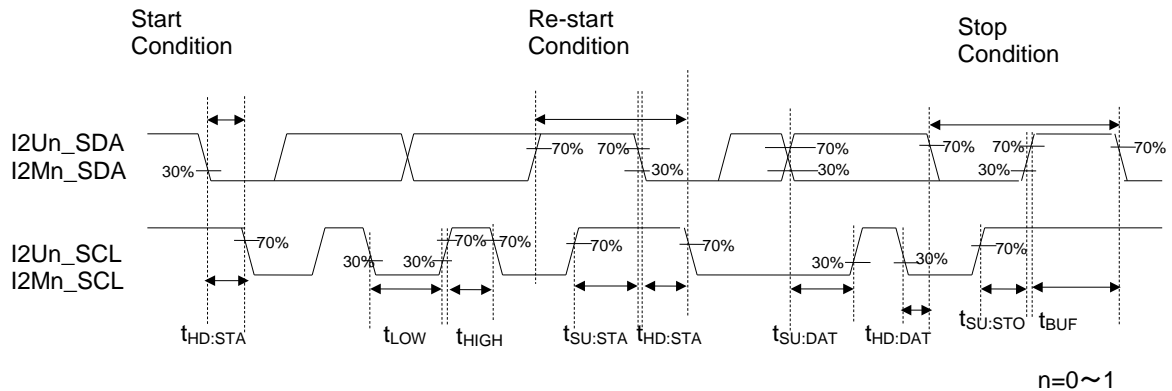

Reset

( $V_{DD}=1.6$  to  $5.5V$ ,  $V_{SS}=0V$ ,  $T_a=-40$  to  $+105^{\circ}C$ , unless otherwise specified)

Parameter	Symbol	Condition	Min.	Typ.	Max.	Unit	Measuring circuit
Reset pulse width	$P_{RST}$	—	2	—	—	ms	1
P00 "H" level setup time	$t_{SP00}$	—	1	—	—	ms	
P00 "H" level hold time	$t_{HP00}$	—	1	—	—	ms	

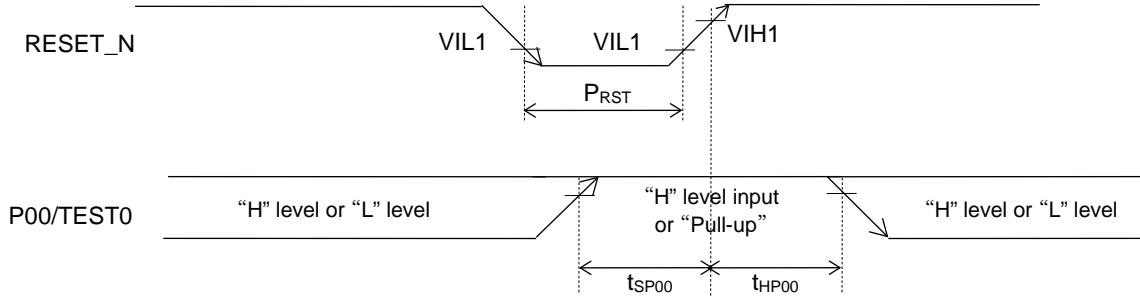

Power On Reset

( $V_{SS}=0V$ ,  $T_a=-40$  to  $+105^{\circ}C$ , unless otherwise specified)

Parameter	Symbol	Condition	Min.	Typ.	Max.	Unit	Measuring circuit
POR detect voltage	$V_{POR}$	Power down(falling)	1.44	1.5	1.58	V	1
		Power up(rising)	1.45	1.53	1.8	V	
Power on rising slope	$R_{POR}^{*1}$	—	0.009	—	60	V/ms	
POR response time	$P_{POR}$	*2	200	—	—	$\mu S$	

\*1: Rise the  $V_{DD}$  to 1.8V or higher when powering on.

\*2: This is the time from the  $V_{DD}$  gets 100mV lower than  $V_{POR}$  to the Power-On-Reset internally generates. Make the power down falling slope 2V/ms or lower(i.e. slower).

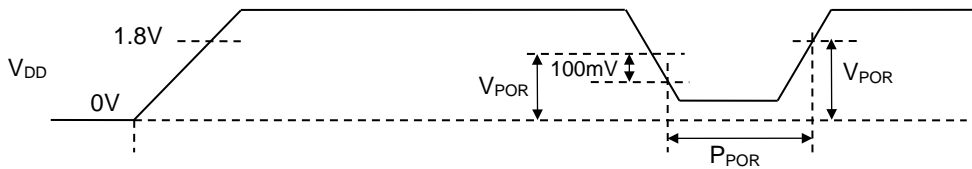

[Note for in case of instantaneous power failure]

In case of instantaneous power failure and a pulse shorter than the response time of VLS or POR is asserted to  $V_{DD}$ , it is possible to make the MCU cannot get the reset and make erroneous operation. In that case, please have countermeasures such as preventing the voltage down using bypass capacitor or making reset pin reset.

## VLS

(V<sub>DD</sub>=1.6 to 5.5V, V<sub>SS</sub>=0V, T<sub>a</sub>=-40 to +105°C, unless otherwise specified)

Parameter	Symbol	Condition		Min.	Typ.	Max.	Unit	Measuring circuit
		VLS0LV * <sup>1</sup>						
VLS threshold voltage * <sup>2</sup>	V <sub>VLSR</sub>	00H	Rising	3.86	4.06	4.26	V	1
	V <sub>VLSF</sub>		Falling	3.84	4.00	4.16		
	V <sub>VLSR</sub>	01H	Rising	3.57	3.76	3.95		
	V <sub>VLSF</sub>		Falling	3.55	3.70	3.85		
	V <sub>VLSR</sub>	02H	Rising	2.94	3.11	3.28		
	V <sub>VLSF</sub>		Falling	2.92	3.05	3.18		
	V <sub>VLSR</sub>	03H	Rising	2.85	3.01	3.17		
	V <sub>VLSF</sub>		Falling	2.83	2.95	3.07		
	V <sub>VLSR</sub>	04H	Rising	2.75	2.91	3.07		
	V <sub>VLSF</sub>		Falling	2.73	2.85	2.97		
	V <sub>VLSR</sub>	05H	Rising	2.66	2.81	2.96		
	V <sub>VLSF</sub>		Falling	2.64	2.75	2.86		
	V <sub>VLSR</sub>	06H	Rising	2.56	2.71	2.86		
	V <sub>VLSF</sub>		Falling	2.54	2.65	2.76		
	V <sub>VLSR</sub>	07H	Rising	2.46	2.61	2.76		
	V <sub>VLSF</sub>		Falling	2.44	2.55	2.66		
	V <sub>VLSR</sub>	08H	Rising	2.37	2.51	2.65		
	V <sub>VLSF</sub>		Falling	2.35	2.45	2.55		
	V <sub>VLSR</sub>	09H	Rising	1.98	2.11	2.24		
	V <sub>VLSF</sub>		Falling	1.96	2.05	2.14		
V <sub>VLSR</sub>	0AH	Rising	1.89	2.01	2.13			
V <sub>VLSF</sub>		Falling	1.87	1.95	2.03			
V <sub>VLSR</sub>	0BH	Rising	1.79	1.91	2.03			
V <sub>VLSF</sub>		Falling	1.77	1.85	1.93			
VLS Current	I <sub>VLS</sub>	—		—	50	—	nA	

\*<sup>1</sup> Bit3~Bit0 of voltage level detection circuit 0 level register (VLS0LV).\*<sup>2</sup> The Data VLS0LV = 0CH~0FH is not available to use, if the data is specified it will the same spec as that 0BH is specified.

## Analog Comparator

(V<sub>DD</sub>=1.8 to 5.5V, V<sub>SS</sub>=0V, T<sub>a</sub>=-40 to +105°C, unless otherwise specified)

Parameter	Symbol	Condition	Min.	Typ.	Max.	Unit	Measuring circuit
Comparator same phase input voltage range	V <sub>CMR</sub>	—	0.1	—	V <sub>DD</sub> -1.5	V	1
Comparator0 input offset	V <sub>CMOF</sub>	T <sub>a</sub> =+25 °C, V <sub>DD</sub> =5.0V	—	5	—	mV	
Comparator Reference Voltage	V <sub>CMREF</sub>	—	0.75	0.8	0.85	V	

Successive Approximation Type A/D Converter

(VDD=1.8 to 5.5V, VSS =0V, Ta=-40 to +105°C, unless otherwise specified)

Parameter	Symbol	Condition	Min.	Typ.	Max.	Unit
Resolution	n	—	—	—	10	bit
Integral non-linearity error	AINL	$2.7V \leq V_{REFP}^{*1} \leq 5.5V$	-4	—	4	LSB
		$2.2V \leq V_{REFP}^{*1} < 2.7V$	-6	—	6	
		$1.8V \leq V_{REFP}^{*1} < 2.2V$	-10	—	10	
		$V_{REFP} = \text{Internal reference voltage}$	-15	—	15	
Differential non-linearity error	ADNL	$2.7V \leq V_{REFP}^{*1} \leq 5.5V$	-3	—	3	LSB
		$2.2V \leq V_{REFP}^{*1} < 2.7V$	-5	—	5	
		$1.8V \leq V_{REFP}^{*1} < 2.2V$	-9	—	9	
		$V_{REFP} = \text{Internal reference voltage}$	-14	—	14	
Zero-scale error	ZSE	$RI \leq 1k\Omega$	-6	—	6	V
Full-scale error	FSE	$RI \leq 1k\Omega$	-6	—	6	
A/D reference voltage	$V_{REFX}$	—	1.8	—	$V_{DD}$	V
Internal reference voltage	$V_{REFI}$	—	1.5	1.55	1.6	
Conversion time	$t_{CONV}$	$4.5V \leq V_{DD} \leq 5.5V$	2.25	—	427	$\mu s$
		$2.2V \leq V_{DD} \leq 5.5V$	4.5	—	427	
		$1.8V \leq V_{DD} \leq 5.5V$	18	—	427	

\*1 : VDD or P23/VREF is selected for the reference voltage of Successive Approximation Type A/D Converter by setting bit5(VREFP1) and bit4(VREFP0) of SA-ADC TEMP/VREF control register(VREFCON).

The current flows during the ADC sampling as it takes charging. Make the output impedance of the analog signal source 1kΩ or smaller. Also, putting 0.1uF capacitor on the ADC input pin is recommended to reduce the noise.

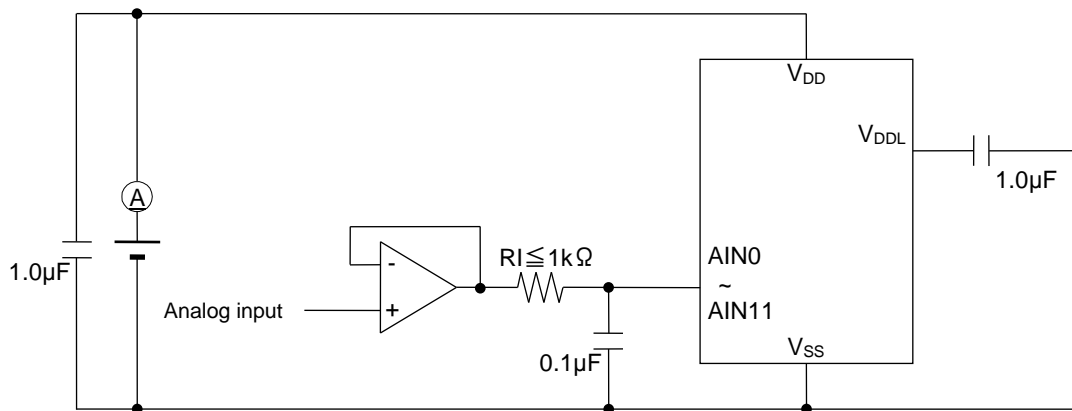

## D/A Converter

(VDD=1.8 to 5.5V, VSS =0V, Ta=-40 to +105°C, unless otherwise specified)

Parameter	Symbol	Condition	Min.	Typ.	Max.	Unit
Resolution	Dn	—	—	—	8	bit
Conversion cycle	tc	—	10	—	—	μs
Integral non-linearity error	DINL	RL=4MΩ	-2	—	2	LSB
Differential non-linearity error	DDNL	RL=4MΩ	-1	—	1	
Output impedance	Ro	DACEN bit of D/A converter enable register =1	3	6	9	kΩ

## Reference Voltage Output

(VDD=1.8 to 5.5V, VSS =0V, Ta=-40 to +105°C, unless otherwise specified)

Parameter	Symbol	Condition	Min.	Typ.	Max.	Unit
Output voltage	V <sub>REFOUT</sub>	—	—	1.55	—	V
Output impedance	R <sub>VREFOUT</sub>	—	—	—	500	kΩ

## Flash Memory

(V<sub>SS</sub>= 0V)

Parameter	Symbol	Condition	Range	Unit	
Operating temperature	T <sub>OP</sub>	Data flash memory, At write/erase	-40 to +85	°C	
		Flash ROM, At write/erase	0 to +40		
Operating voltage	V <sub>DD</sub>	At write/erase	+1.8 to +5.5	V	
Maximum rewrite count	CEPD	Data Flash (1024Byte x2)	10000	times	
	CEPP	Program Flash	100		
Erase unit	—	Block erase	Program Flash	16K	B
			Data Flash	2K	
	—	Sector erase	Program Flash	1K	B
			Data Flash	128	
Erase time (Max.)	—	Block erase / Sector erase	85	ms	
Write unit	—	Program Flash	4	B	
		Data Flash	1		
Write time (Max.)	—	Program Flash	80	μs	
	—	Data Flash	40		
Data retention period	YDR	—	15	years	

## Measuring circuit 1

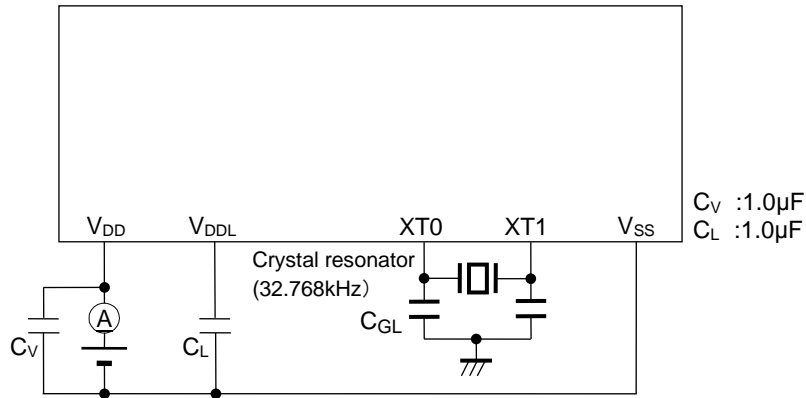

## Measuring circuit 2

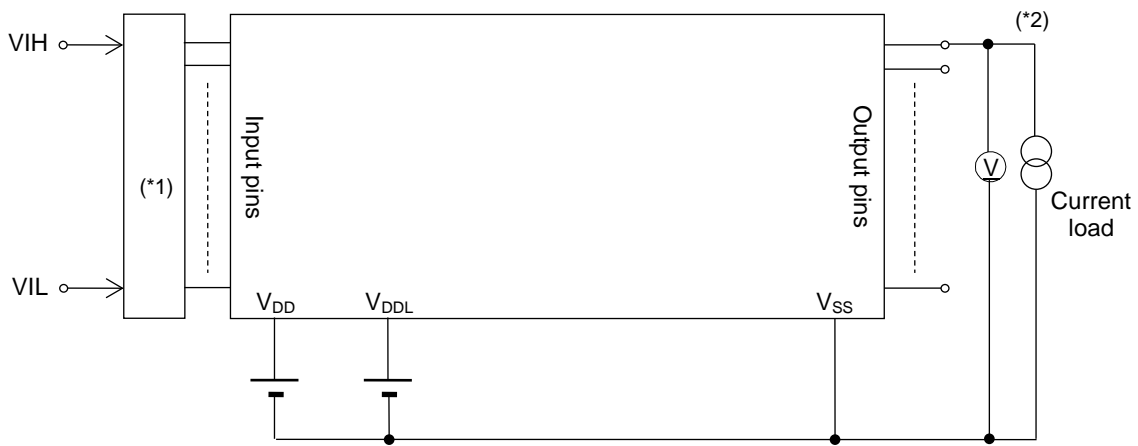

- (\*1) Input logic circuit to determine the specified measuring conditions
- (\*2) Measured connecting specified pins

## Measuring circuit 3

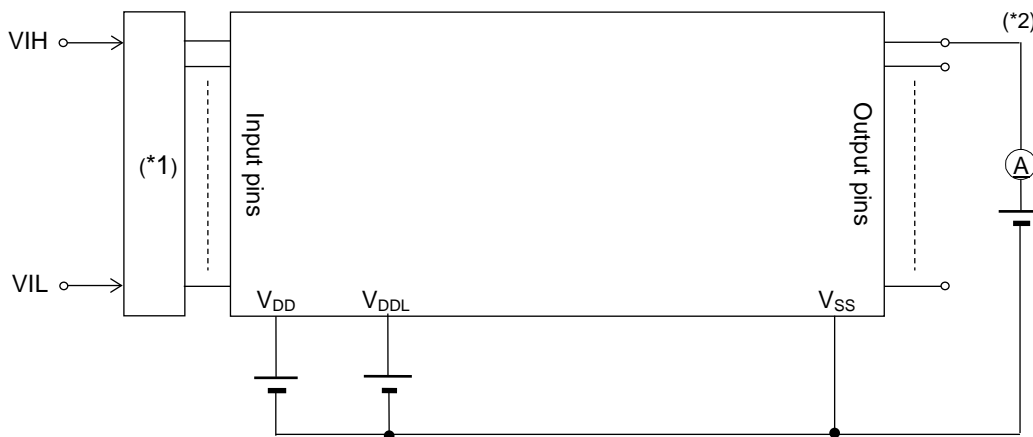

- (\*1) Input logic circuit to determine the specified measuring conditions
- (\*2) Measured connecting specified pins

## Measuring circuit 4

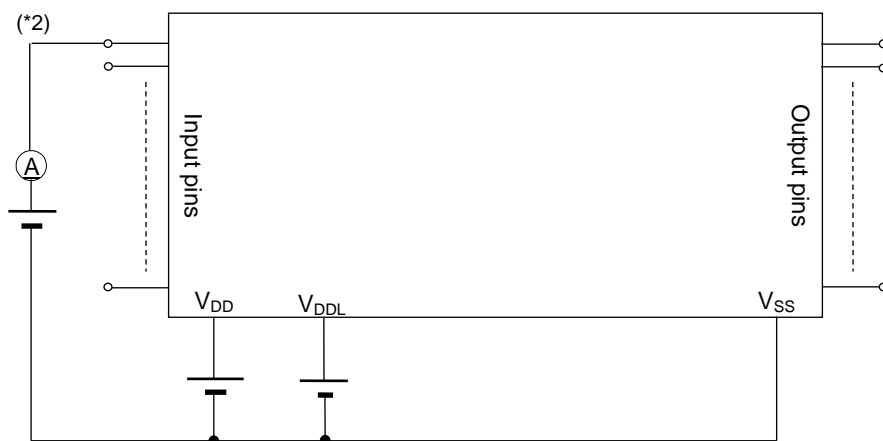

(\*2) Measured connecting specified pins

## Measuring circuit 5

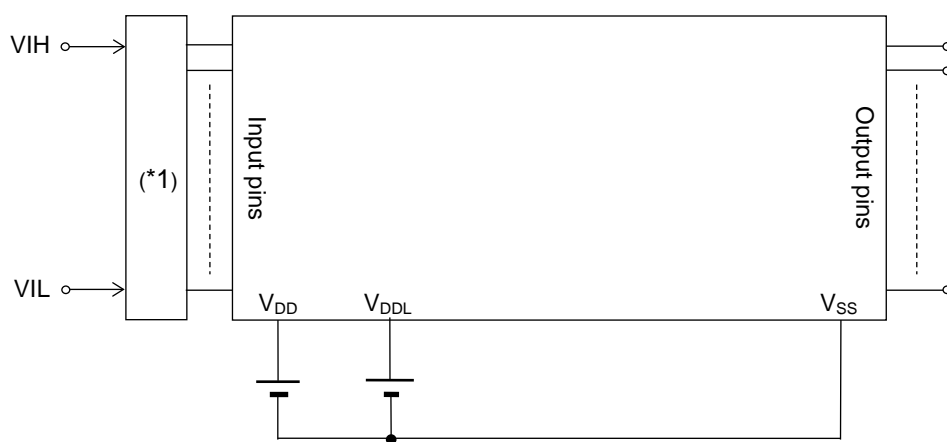

(\*1) Input logic circuit to determine the specified measuring conditions

# LAPIS Semiconductor Co.,Ltd.

FEDL62Q1400-05

## Characteristics graphs

These Graphs on the following pages are references for designing an application.

IOH vs VDD-VOH1

(VDD=5V TYP.)

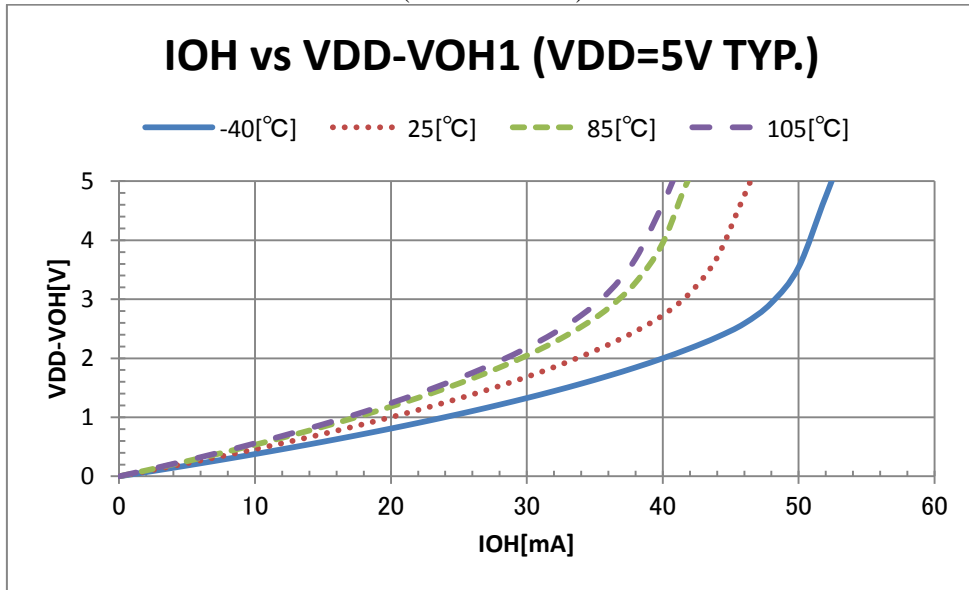

(VDD=3V TYP.)

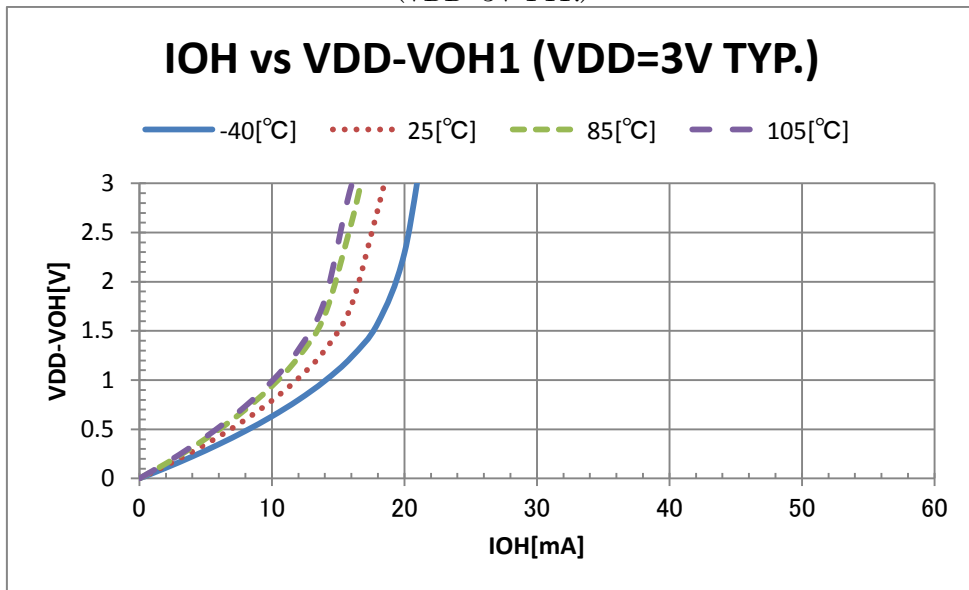

IOL VS VOL1

(VDD=5V TYP.)

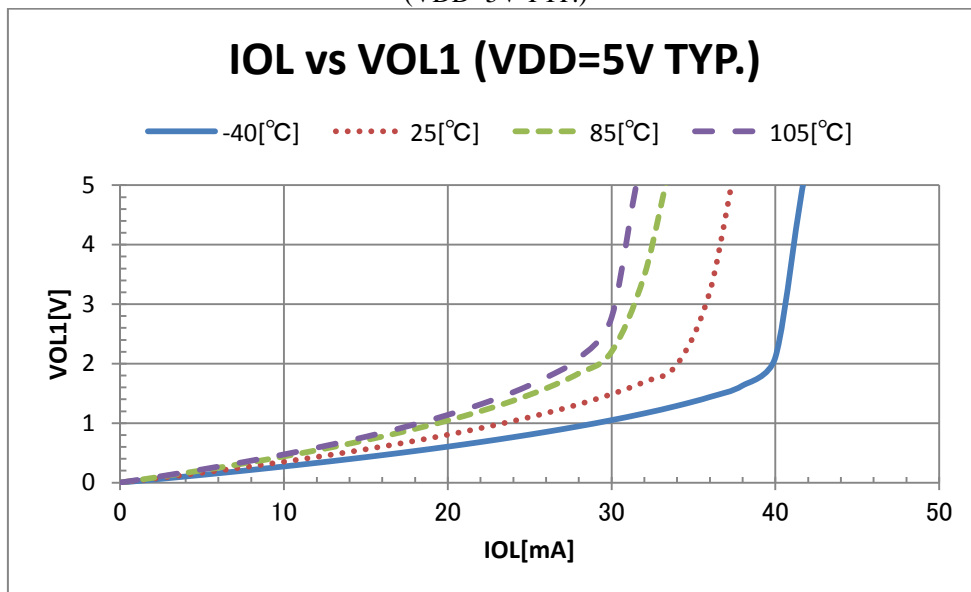

(VDD=3V TYP.)

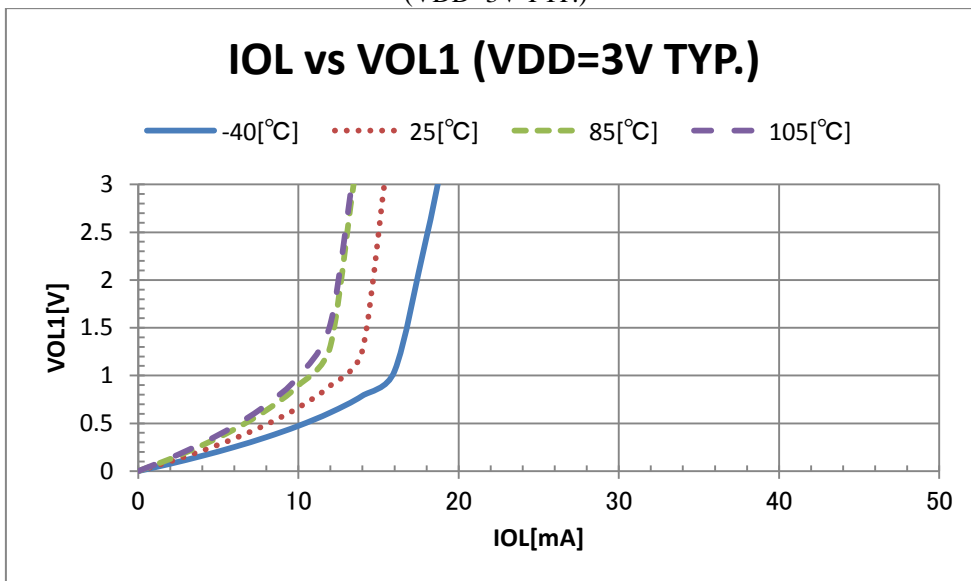

IOL VS VOL2

(VDD=5V TYP.)

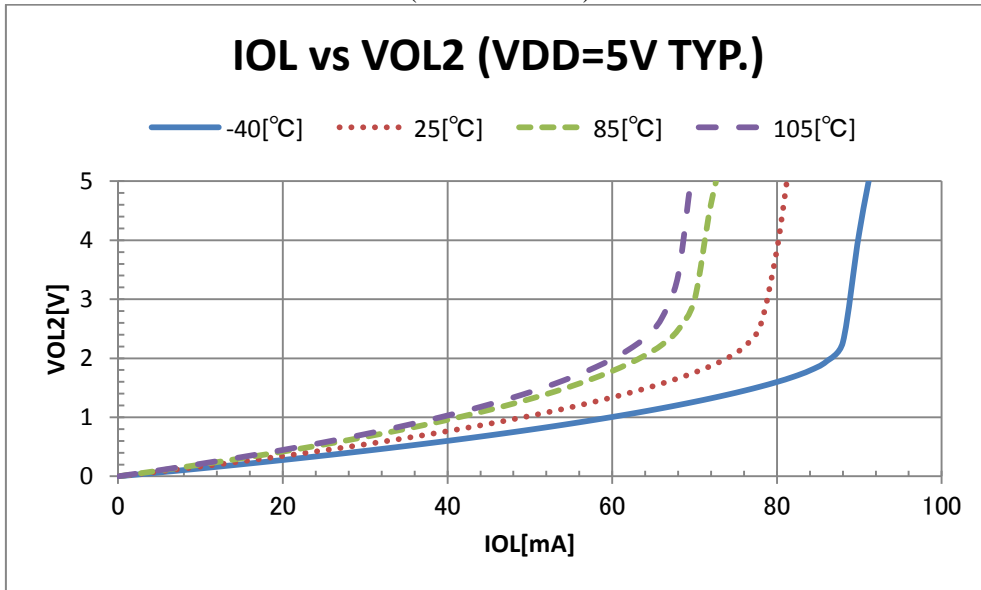

(VDD=3V TYP.)

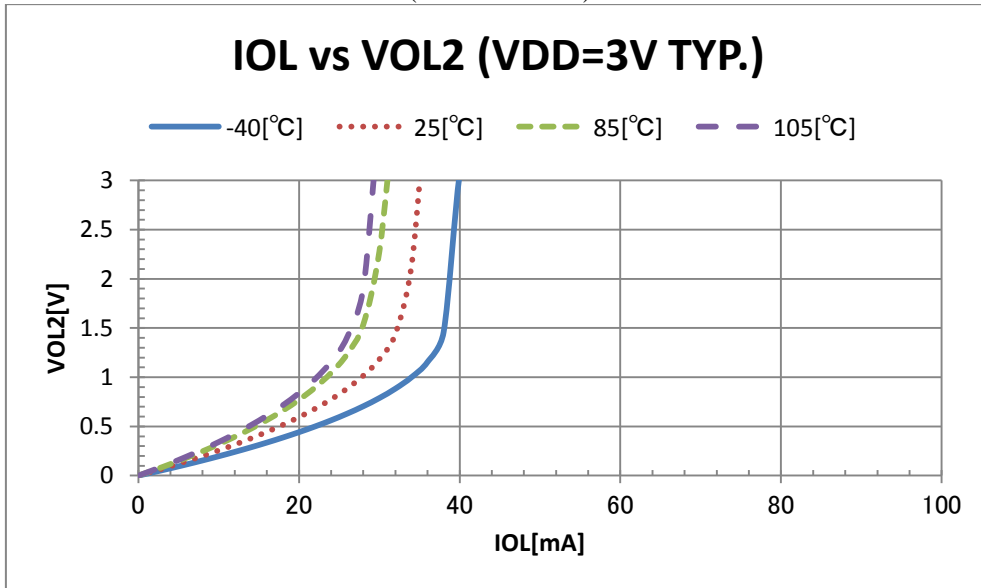

Pull-up resistor

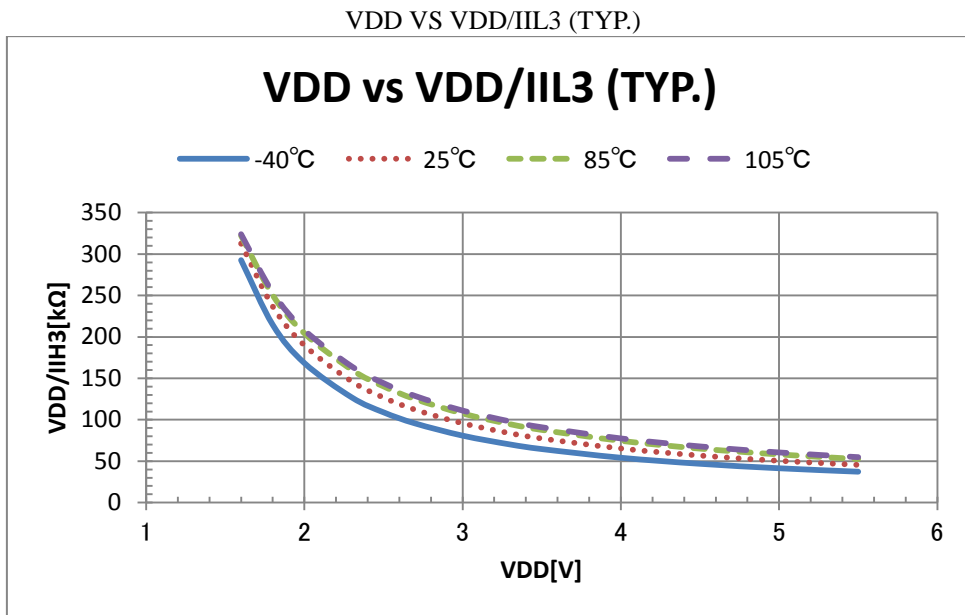
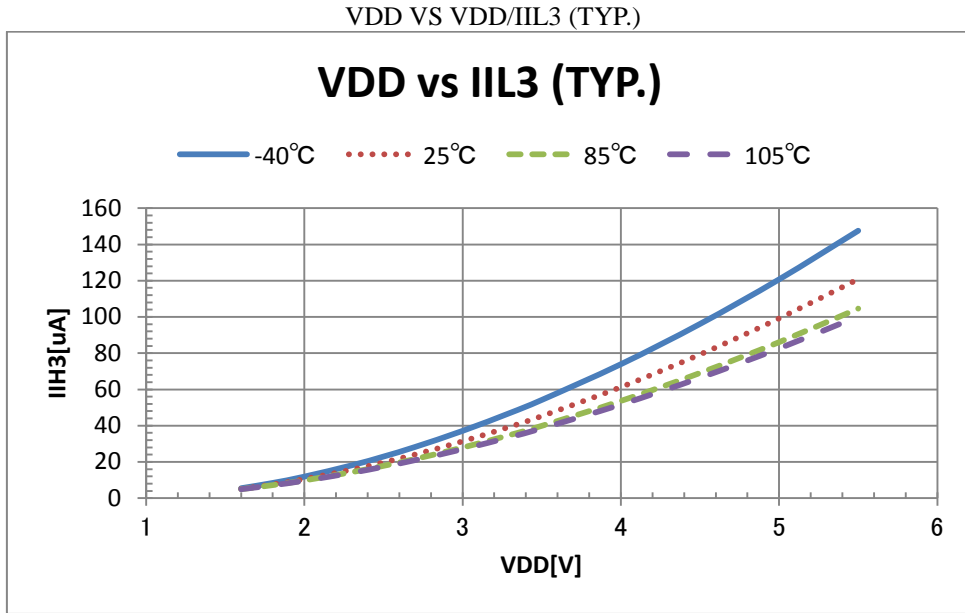

Current consumption VS operating frequency of CPU

VDD=3V, temp=+25°C, stop the clock supply to peripherals.  
PLL 16MHz mode, CPU Wait mode (TYP.)

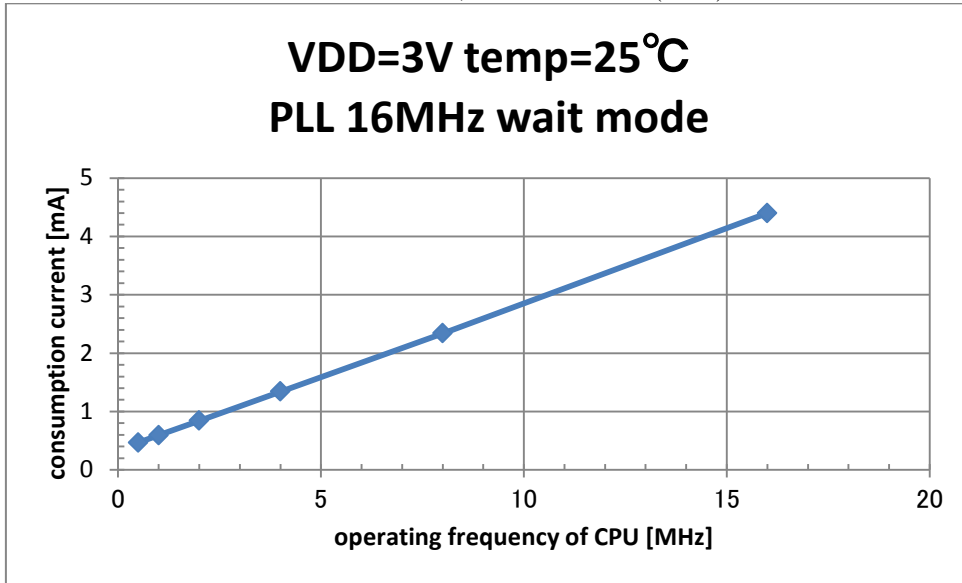

PLL 16MHz mode, CPU no Wait mode (TYP.)

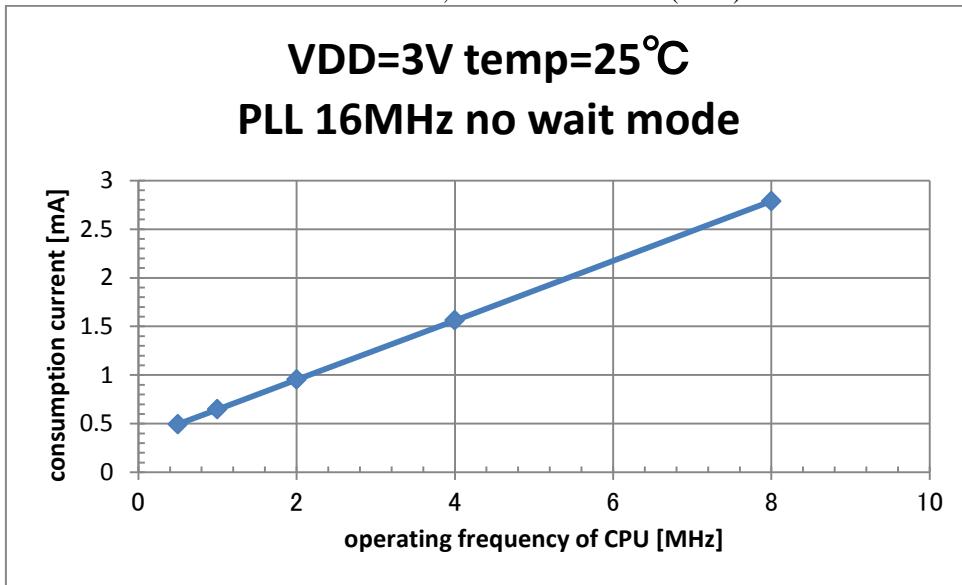

VDD=3V, temp=+25°C, stop the clock supply to peripherals.

PLL 24MHz mode, CPU Wait mode (TYP.) (IDD5)

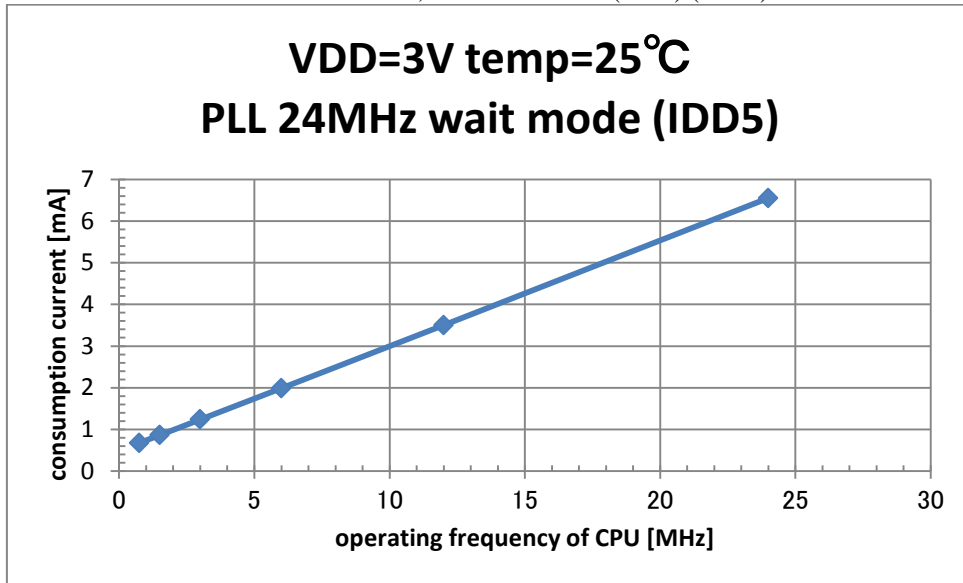

PLL 24MHz mode, CPU no Wait mode (TYP.)

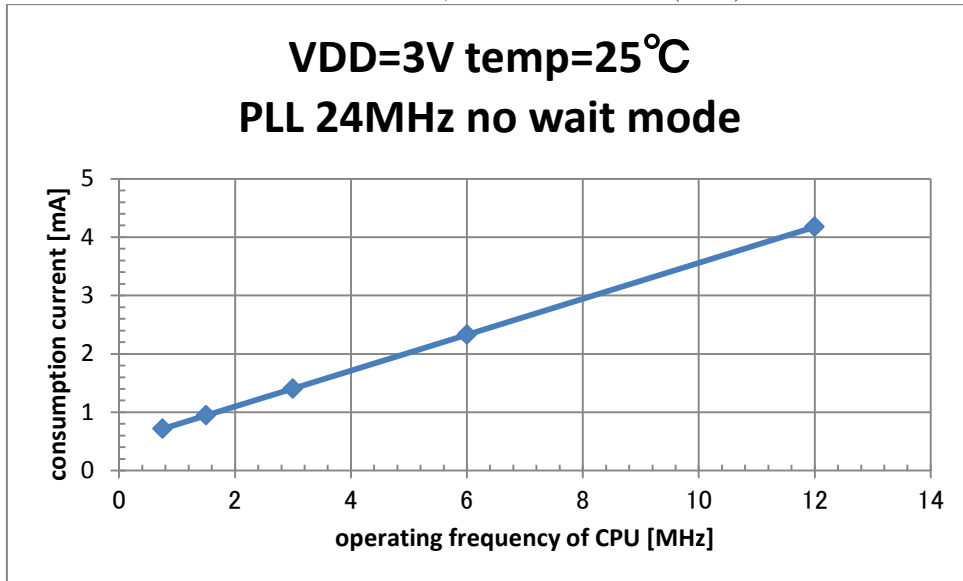

VDD=3V, temp=+25°C, stop the clock supply to peripherals.

PLL 32MHz mode, CPU Wait mode (TYP) (IDD4)

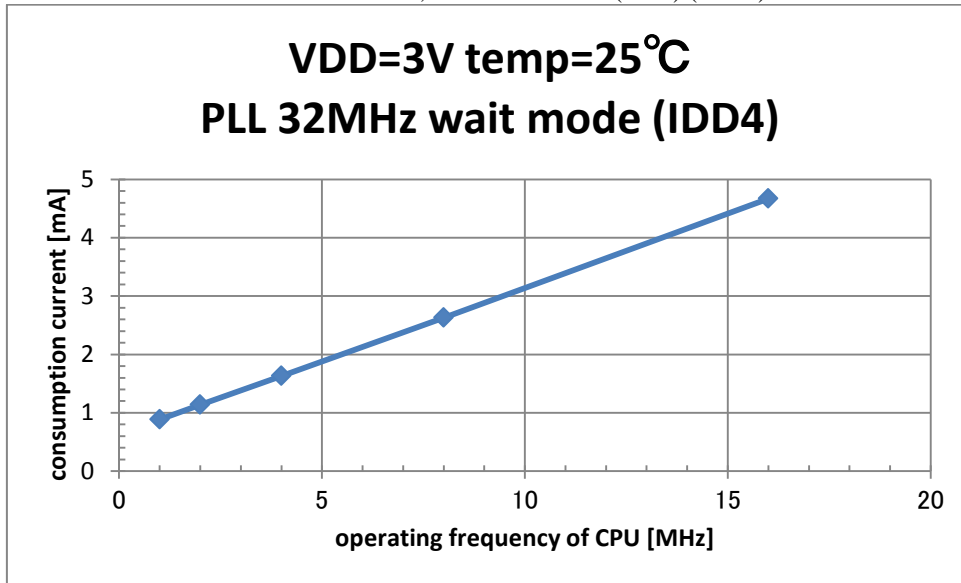

PLL 32MHz mode, CPU no Wait mode (TYP)

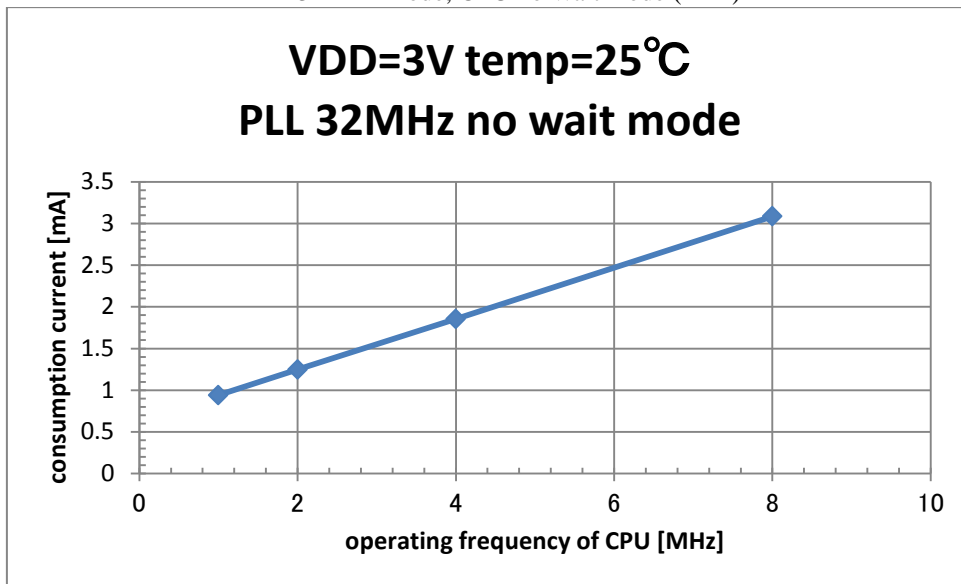

Consumption current of ADC VS operating voltage

Temp=+25°C (TYP)

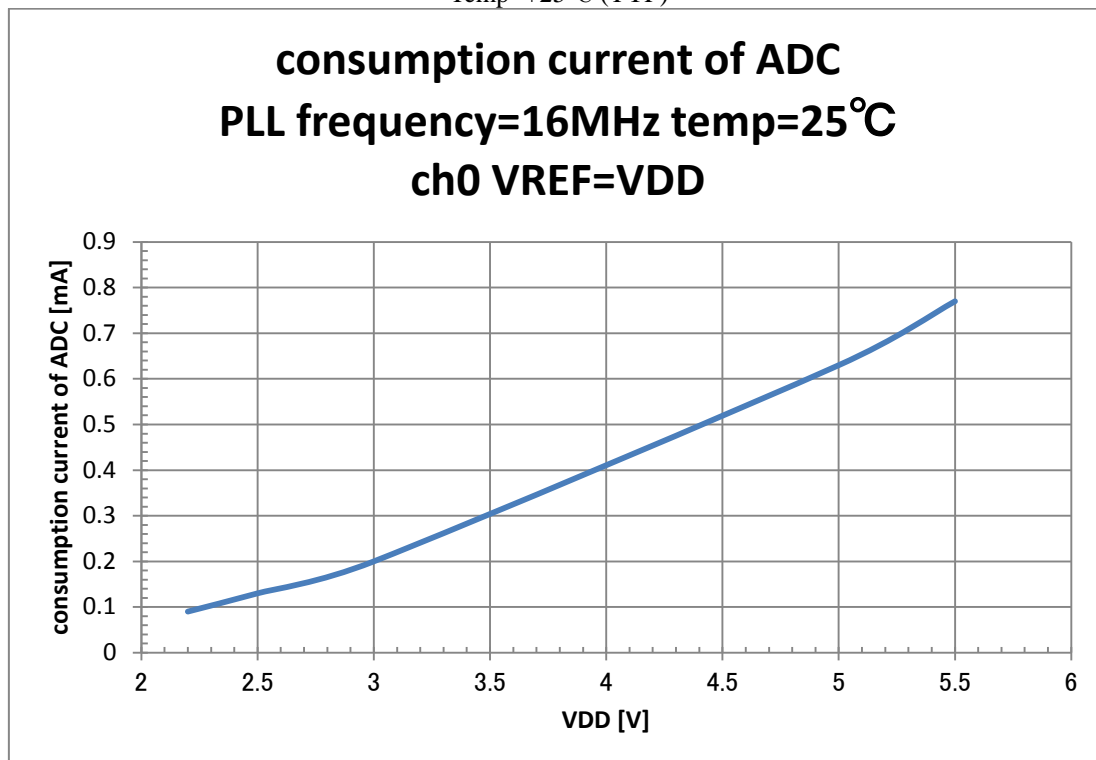

DIGITAL OUTPUT CODE vs absolute error of ADC

Temp=-40°C (TYP.)

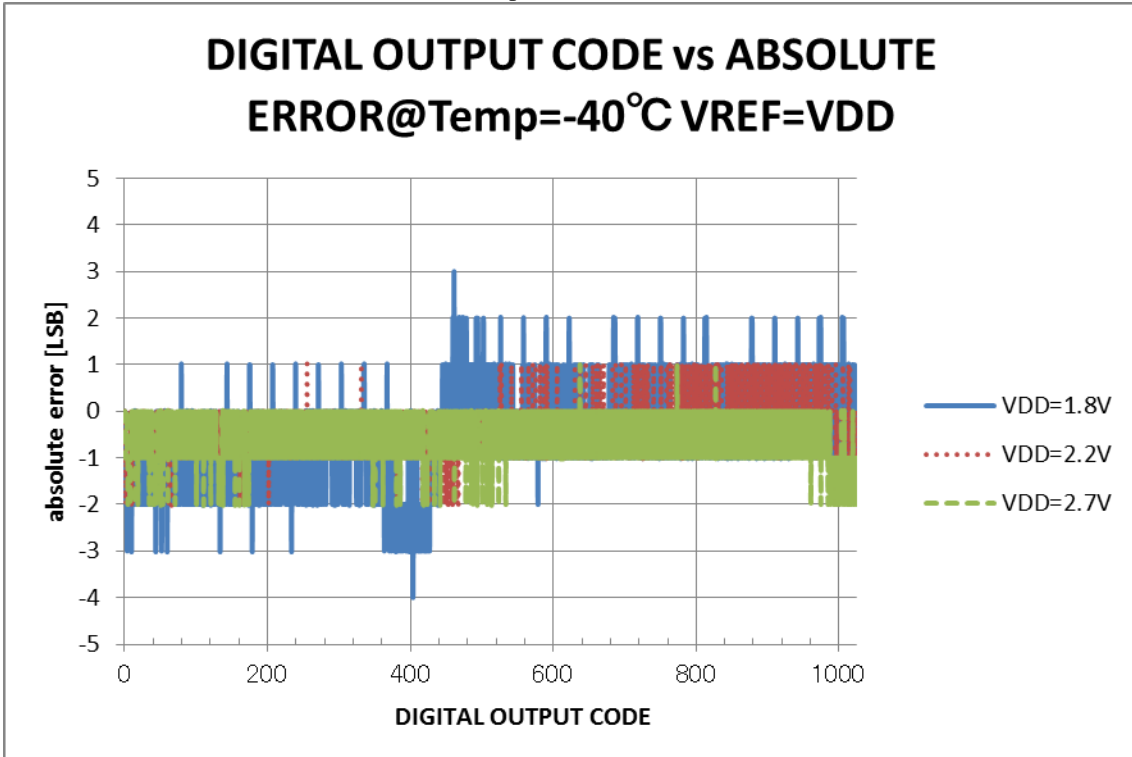

Temp=+25°C (TYP.)

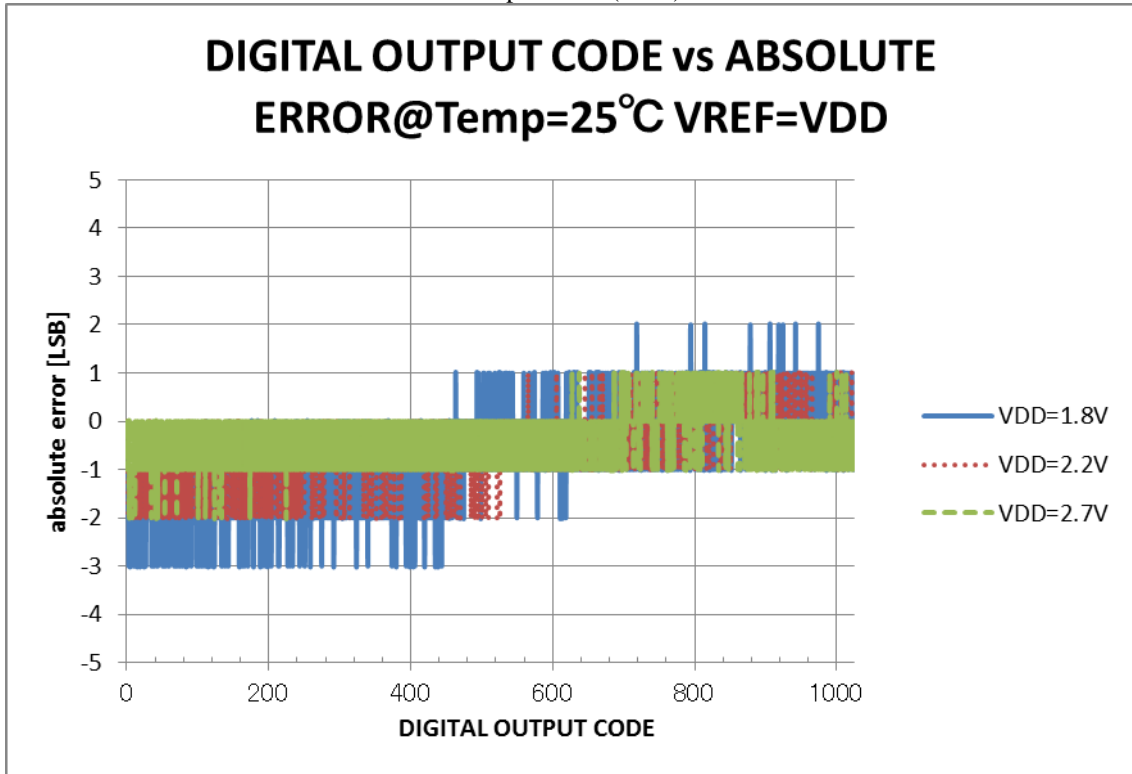

Temp=+105°C (TYP.)

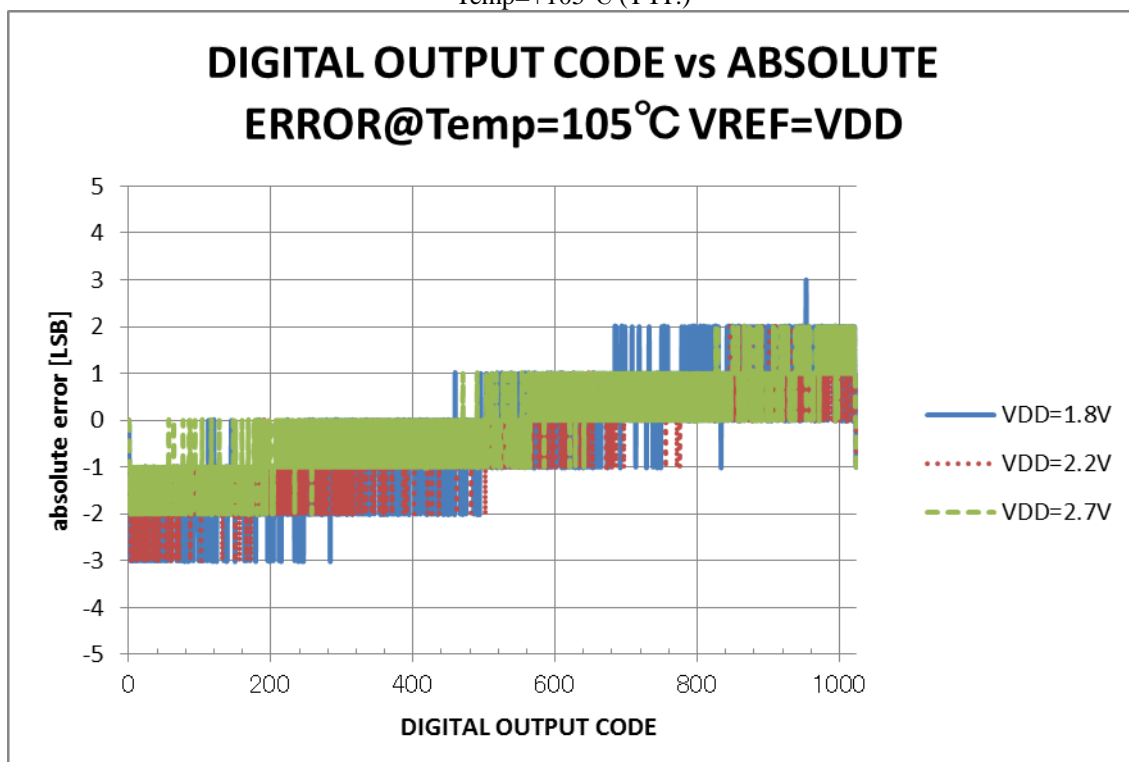

PACKAGE DIMENSIONS

ML62Q1430/1431/1432 48pin TQFP Package

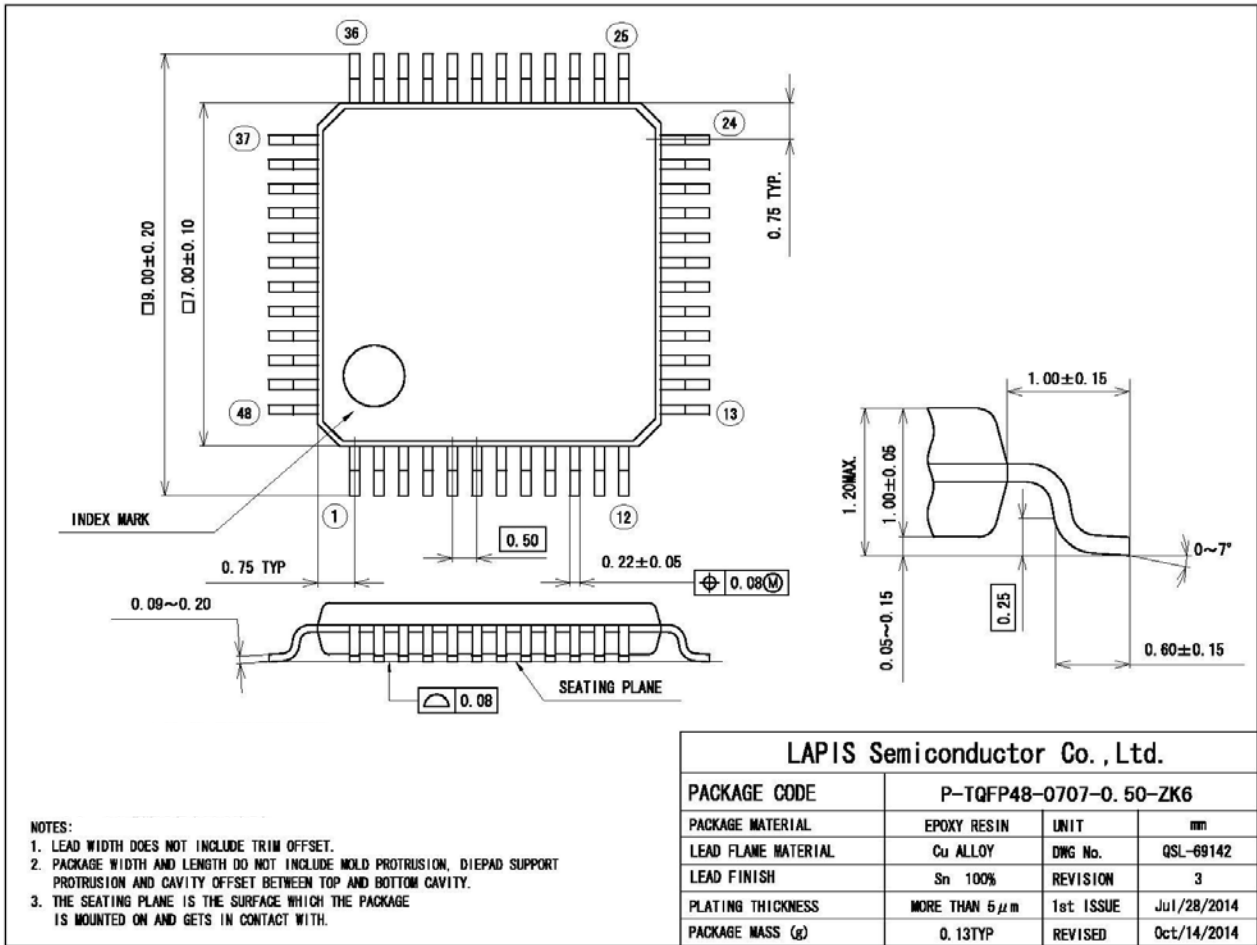

- NOTES:
1. LEAD WIDTH DOES NOT INCLUDE TRIM OFFSET.
  2. PACKAGE WIDTH AND LENGTH DO NOT INCLUDE MOLD PROTRUSION, DIEPAD SUPPORT PROTRUSION AND CAVITY OFFSET BETWEEN TOP AND BOTTOM CAVITY.
  3. THE SEATING PLANE IS THE SURFACE WHICH THE PACKAGE IS MOUNTED ON AND GETS IN CONTACT WITH.

(Unit: mm)

Notes for Mounting the Surface Mount Type Package

The surface mount type packages are very susceptible to heat in reflow mounting and humidity absorbed in storage. Therefore, before you perform reflow mounting, contact a ROHM sales office for the product name, package name, pin number, package code and desired mounting conditions (reflow method, temperature and times).

ML62Q1440/1441/1442 52pin TQFP Package

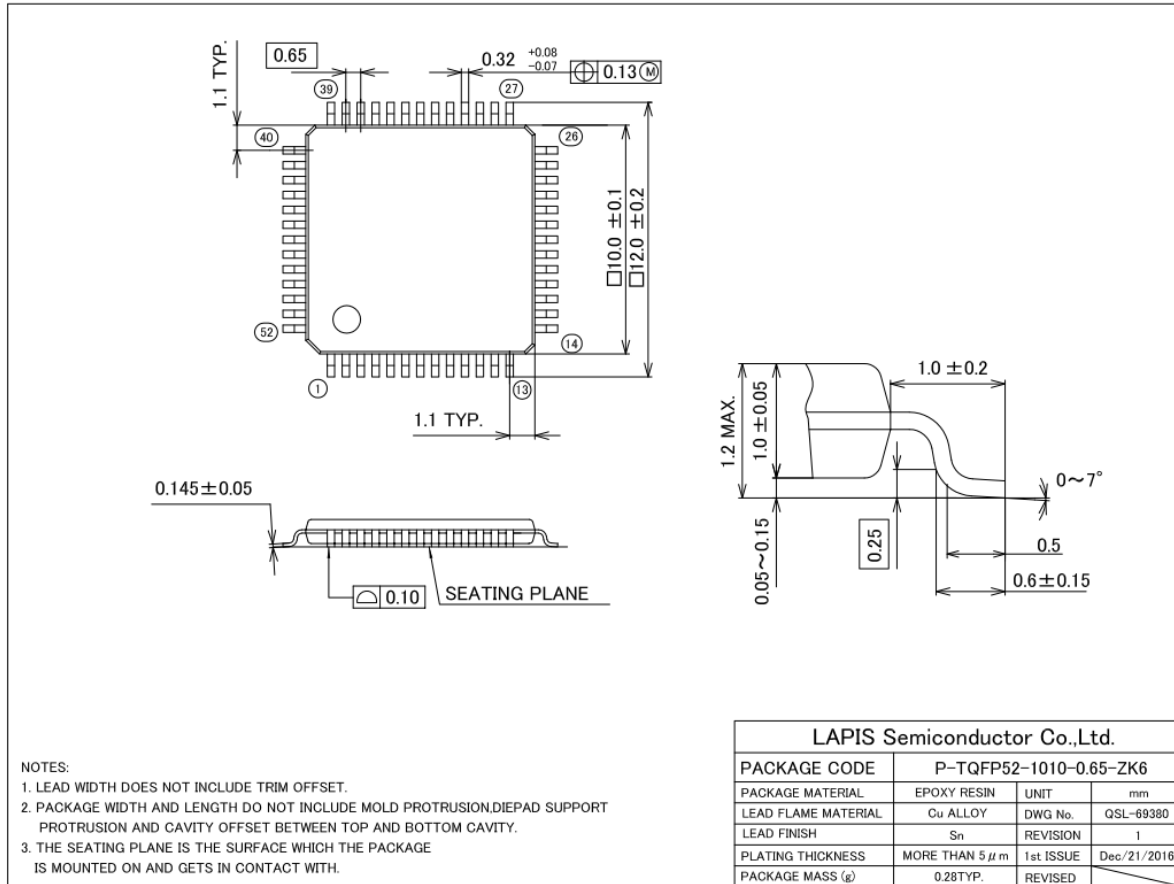

NOTES:

1. LEAD WIDTH DOES NOT INCLUDE TRIM OFFSET.
2. PACKAGE WIDTH AND LENGTH DO NOT INCLUDE MOLD PROTRUSION, DIEPAD SUPPORT PROTRUSION AND CAVITY OFFSET BETWEEN TOP AND BOTTOM CAVITY.
3. THE SEATING PLANE IS THE SURFACE WHICH THE PACKAGE IS MOUNTED ON AND GETS IN CONTACT WITH.

(Unit: mm)

Notes for Mounting the Surface Mount Type Package

The surface mount type packages are very susceptible to heat in reflow mounting and humidity absorbed in storage. Therefore, before you perform reflow mounting, contact a ROHM sales office for the product name, package name, pin number, package code and desired mounting conditions (reflow method, temperature and times).

## ML62Q1450/1451/1452 64pin TQFP Package

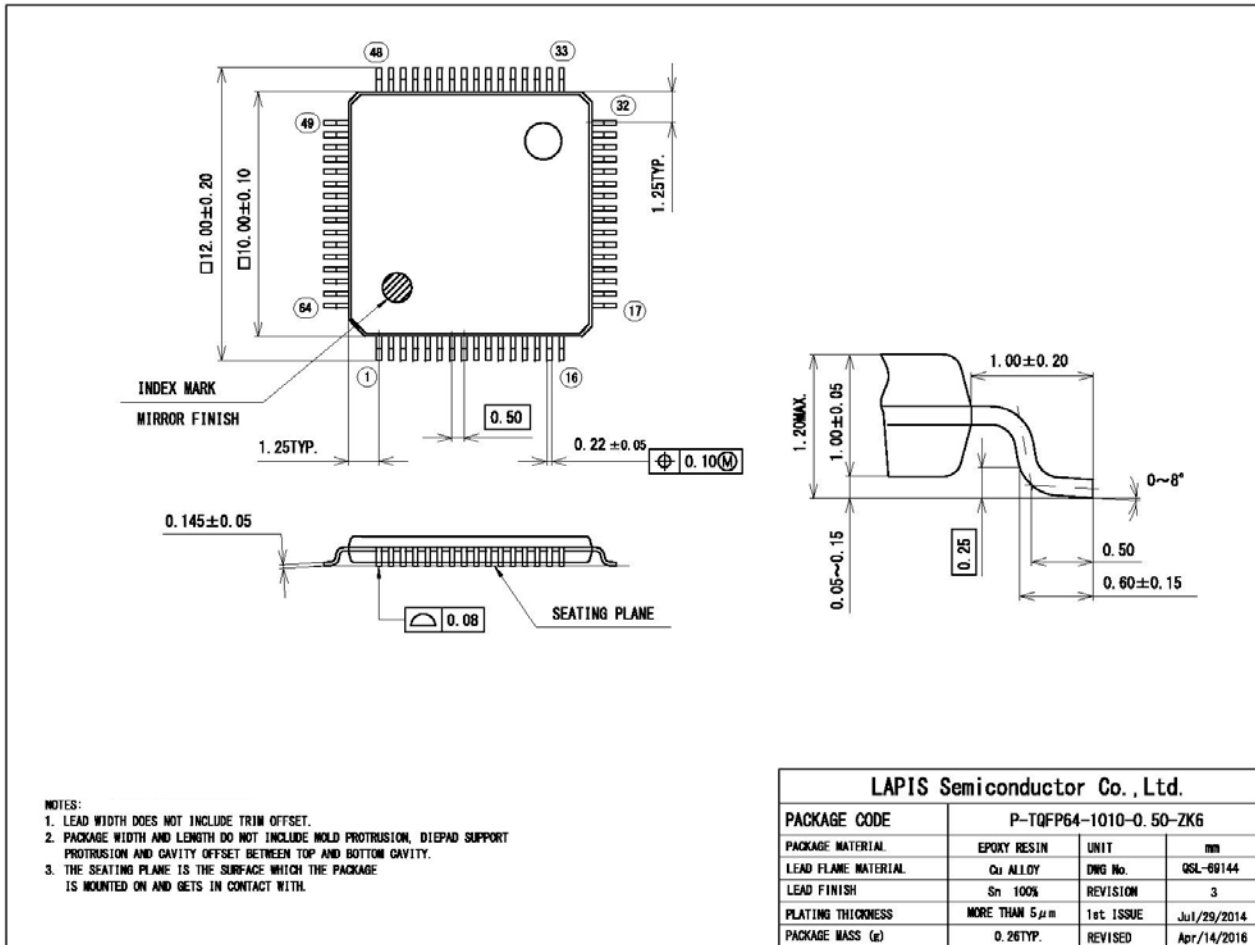

(Unit: mm)

### Notes for Mounting the Surface Mount Type Package

The surface mount type packages are very susceptible to heat in reflow mounting and humidity absorbed in storage. Therefore, before you perform reflow mounting, contact a ROHM sales office for the product name, package name, pin number, package code and desired mounting conditions (reflow method, temperature and times).

ML62Q1450/1451/1452 64pin QFP Package

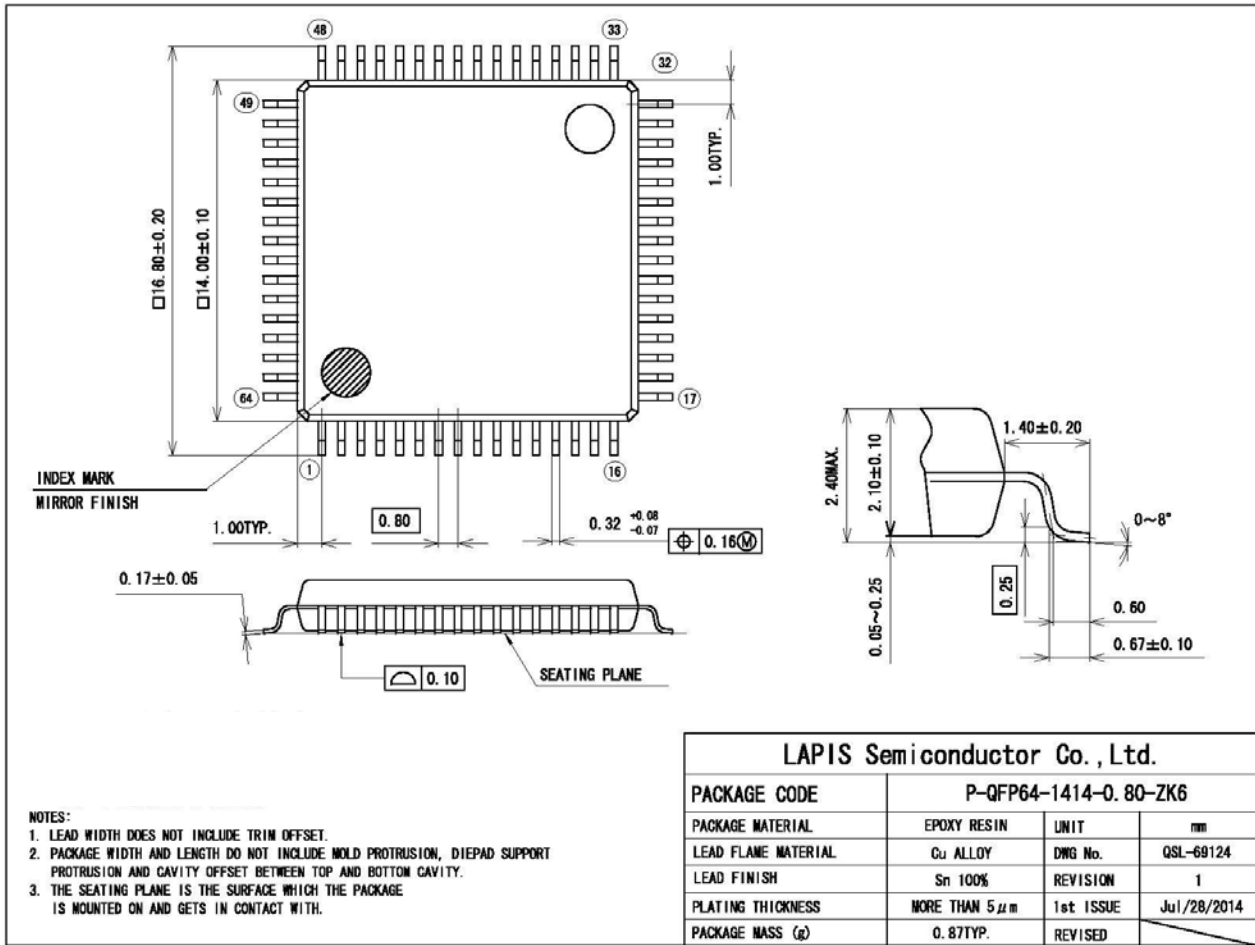

(Unit: mm)

Notes for Mounting the Surface Mount Type Package

The surface mount type packages are very susceptible to heat in reflow mounting and humidity absorbed in storage. Therefore, before you perform reflow mounting, contact a ROHM sales office for the product name, package name, pin number, package code and desired mounting conditions (reflow method, temperature and times).

## REVISION HISTORY

Document No.	Date	Page		Description
		Previous Edition	Current Edition	
FEDL62Q1400-01	Oct 19, 2017	-	-	Formal 1 <sup>st</sup> Revision.
FEDL62Q1400-02	Nov 1, 2017	3	3	Added description about Simplified RTC.
		28,33,34	28,33,34	Added description about the current.
		33	33	Added IOH1 condition. "VOH $\geq$ VDD-0.5"
FEDL62Q1400-04	May 11, 2018	-	-	The 3 <sup>rd</sup> Revision (-03) is skipped to match the revision number to Japanese User's Manual.
		3	3	Added the available CPU operation mode for the DMA.
		5	5	Corrected the kind of reference voltage for ADC.
		29	29	Added the condition of V <sub>DD</sub> for IDD4/IDD5.
		30	30	Added the spec of input pulse width (tEXCKW).
		28,32,33	28,32,33	Changed the word "High"/ "Low" level to "H"/"L" level.
		32,33	32,33	Added P00 for IOH1 and IOL3. Changed overall spec of IOH/IOL and VOH/VOL.
		34	35	Added the pull-up resistance value in the spec of Input current 2 and Input current 3.
		35~39	35~39	Added "n=0~1" in the figures.
		39	40	Changed the spec of t <sub>SU:DAT</sub> (0.05us d the s) in the 1Mbps Mode.
		35~39	36~40	Changed the channel number of serial ports : "0" or "1" to "n"
		40	41	<ul style="list-style-type: none"> <li>Added minimum value of R<sub>POR</sub>.</li> <li>Added the sped of P00 setup/hold time</li> </ul>
		42	43	<ul style="list-style-type: none"> <li>Corrected the conditions of Conversion time "2.2V<math>\leq</math>V<sub>DD</sub><math>\leq</math>5.5V" <math>\rightarrow</math> "2.7V<math>\leq</math>V<sub>DD</sub><math>\leq</math>5.5V" "V<sub>DD</sub> = 5.0V" <math>\rightarrow</math> "4.5V<math>\leq</math>V<sub>DD</sub><math>\leq</math>5.0V"</li> <li>Added a note for the external component of the ADC input.</li> </ul>
		42,43	43,44	Seperate the symbol of INL and DNL between ADC and DAC.
		44	45	Added the crystal oscillation circuit to the measuring circuit 1.
-	47~57	Added the characteristic graphs.		
47	58	Changed the figure for 48pin TQFP package dimension		
Over all	Over all	Added "+" to the positive temperatures (25 $^{\circ}$ C , 85 $^{\circ}$ C , 105 $^{\circ}$ C $\rightarrow$ +25 $^{\circ}$ C , +85 $^{\circ}$ C , +105 $^{\circ}$ C ).		
FEDL62Q1400-05	May 31, 2018	33,34	33,34	Added the note "6 :Nch open drain output mode" for IOL3 and IOL2.

## Notes

- 1) The information contained herein is subject to change without notice.
- 2) Although LAPIS Semiconductor is continuously working to improve product reliability and quality, semiconductors can break down and malfunction due to various factors. Therefore, in order to prevent personal injury or fire arising from failure, please take safety measures such as complying with the derating characteristics, implementing redundant and fire prevention designs, and utilizing backups and fail-safe procedures. LAPIS Semiconductor shall have no responsibility for any damages arising out of the use of our Products beyond the rating specified by LAPIS Semiconductor.
- 3) Examples of application circuits, circuit constants and any other information contained herein are provided only to illustrate the standard usage and operations of the Products. The peripheral conditions must be taken into account when designing circuits for mass production.
- 4) The technical information specified herein is intended only to show the typical functions of the Products and examples of application circuits for the Products. No license, expressly or implied, is granted hereby under any intellectual property rights or other rights of LAPIS Semiconductor or any third party with respect to the information contained in this document; therefore LAPIS Semiconductor shall have no responsibility whatsoever for any dispute, concerning such rights owned by third parties, arising out of the use of such technical information.
- 5) The Products are intended for use in general electronic equipment (i.e. AV/OA devices, communication, consumer systems, gaming/entertainment sets) as well as the applications indicated in this document.
- 6) The Products specified in this document are not designed to be radiation tolerant.
- 7) For use of our Products in applications requiring a high degree of reliability (as exemplified below), please contact and consult with a LAPIS Semiconductor representative: transportation equipment (i.e. cars, ships, trains), primary communication equipment, traffic lights, fire/crime prevention, safety equipment, medical systems, servers, solar cells, and power transmission systems.
- 8) Do not use our Products in applications requiring extremely high reliability, such as aerospace equipment, nuclear power control systems, and submarine repeaters.
- 9) LAPIS Semiconductor shall have no responsibility for any damages or injury arising from non-compliance with the recommended usage conditions and specifications contained herein.
- 10) LAPIS Semiconductor has used reasonable care to ensure the accuracy of the information contained in this document. However, LAPIS Semiconductor does not warrant that such information is error-free and LAPIS Semiconductor shall have no responsibility for any damages arising from any inaccuracy or misprint of such information.
- 11) Please use the Products in accordance with any applicable environmental laws and regulations, such as the RoHS Directive. For more details, including RoHS compatibility, please contact a ROHM sales office. LAPIS Semiconductor shall have no responsibility for any damages or losses resulting non-compliance with any applicable laws or regulations.
- 12) When providing our Products and technologies contained in this document to other countries, you must abide by the procedures and provisions stipulated in all applicable export laws and regulations, including without limitation the US Export Administration Regulations and the Foreign Exchange and Foreign Trade Act.
- 13) This document, in part or in whole, may not be reprinted or reproduced without prior consent of LAPIS Semiconductor.

Copyright 2017-2018 LAPIS Semiconductor Co., Ltd.

---

## LAPIS Semiconductor Co.,Ltd.

2-4-8 Shinyokohama, Kouhoku-ku,  
Yokohama 222-8575, Japan  
<http://www.lapis-semi.com/en/>