

## Data Sheet | Item Number: 285-195

2-conductor through terminal block; 95 mm<sup>2</sup>; lateral marker slots; only for DIN 35 x 15 rail; POWER CAGE CLAMP; 95,00 mm<sup>2</sup>; gray

<https://www.wago.com/285-195>

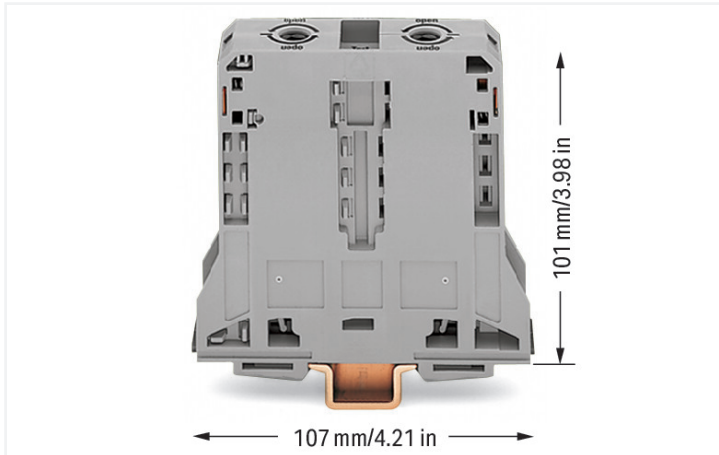

Color: ■ gray

High-current terminal block, 285 Series, gray

Our through terminal block (item number 285-195) simplifies electrical installations. Ensure that the strip lengths are 35 mm when connecting conductors to this through terminal block. This product features conductor terminals and utilizes POWER CAGE CLAMP. The POWER CAGE CLAMP is perfect for connecting large conductor cross-sections. This universal connector is both reliable and maintenance-free. What's more, you can use it to connect all types of conductors and the clamping point can be locked open, making it easier to use. You do not need to use a torque wrench or prepare the conductor. For example, crimping ferrules is not necessary. Depending on the conductor type, this through terminal block is designed for conductor cross sections ranging from 25 mm<sup>2</sup> to 95 mm<sup>2</sup>.

### Electrical data

Ratings per	IEC/EN 60947-7-1		
Overtoltage category	III	III	II
Pollution degree	3	2	2
Nominal voltage	1000 V	-	-
Rated impulse withstand voltage	12 kV	-	-
Rated current	232 A	-	-

Ratings per IEC/EN 2	
Rated voltage (III / 3)	1500 V
Rated impulse withstand voltage (III/3)	12 kV

Approvals per	UL 1059		
Use group	B	C	D
Rated voltage	600 V	600 V	-
Rated current	200 A	200 A	-

Approvals per	CSA 22.2 No 158		
Use group	B	C	D
Rated voltage	1000 V	1000 V	-
Rated current	210 A	-	-

Power Loss	
Power loss, per pole (potential)	7.5354 W
Rated current $I_N$ for power loss specification	232 A
Resistance value for specified, current-dependent power loss	0.00014 Ω

General information	
Voltage type 1	AC/DC
Voltage type 2	DC
Wiring direction	Side-entry wiring

### Connection Data

Clamping units	2
Total number of potentials	1
Number of levels	1
Number of jumper slots	2

### Connection 1

Connection technology	POWER CAGE CLAMP
Actuation type	T-wrench; 8 mm
Connectable conductor materials	Copper
Nominal cross-section	95 mm <sup>2</sup>
Solid conductor	25 ... 95 mm <sup>2</sup> / 4 ... 4/0 AWG
Stranded conductor	25 ... 95 mm <sup>2</sup> / 4 ... 4/0 AWG
Fine-stranded conductor	25 ... 95 mm <sup>2</sup> / 4 ... 4/0 AWG
Fine-stranded conductor; with insulated ferrule	25 ... 95 mm <sup>2</sup> / 4 ... 4/0 AWG
Fine-stranded conductor; with uninsulated ferrule	25 ... 95 mm <sup>2</sup> / 4 ... 4/0 AWG
Strip length	35 mm / 1.38 inches
Wiring direction	Side-entry wiring

### Physical data

Width	25 mm / 0.984 inches
Height	107 mm / 4.213 inches
Depth from upper-edge of DIN-rail	101 mm / 3.976 inches

### Mechanical data

Mounting type	DIN-35 x 15 rail
Mounting (note)	only suitable for DIN 35 x 15 rail
Marking level	Side marking

### Material data

Note (material data)	<a href="#">Information on material specifications can be found here</a>
Color	gray
Material group	I
Insulation material (main housing)	Polyamide (PA66)
Flammability class per UL94	V0
Fire load	3.556 MJ
Weight	264.3 g

### Environmental requirements

Processing temperature	-35 ... +85 °C
Continuous operating temperature	-60 ... +105 °C

### Environmental Testing

Test specification: Railway applications – Rolling stock – Electronic equipment	DIN EN 50155 (VDE 0115-200):2022-06
Test procedure: Railway applications – Rolling stock equipment – Vibration and shock tests	DIN EN 61373 (VDE 0115-0106):2011-04
Spectrum/Mounting location	Service life test, Category 1, Class A/B
Functional test with noise-like oscillations	Test passed according to Section 8 of the standard
Frequency	f <sub>1</sub> = 5 Hz to f <sub>2</sub> = 150 Hz
Acceleration	0.101g (highest test level used for all axes)
Test duration per axis	10 min.
Test directions	X, Y and Z axes

### Environmental Testing

Monitoring of contact faults and interruptions	Passed
Voltage drop measurement before and after each axis	Passed
Simulated service life test through increased levels of noise-like oscillations	Test passed according to Section 9 of the standard
Frequency	$f_1 = 5 \text{ Hz}$ to $f_2 = 150 \text{ Hz}$
Acceleration	0.572g (highest test level used for all axes)
Test duration per axis	5 h
Test directions	X, Y and Z axes
Extended testing: Monitoring of contact faults and interruptions	Passed
Extended testing: Voltage drop measurement before and after each axis	Passed
Shock test	Test passed according to Section 10 of the standard
Shock pulse form	Half sine
Acceleration	5g (highest test level used for all axes)
Shock duration	30 ms
Number of shocks (per axis)	3 pos. und 3 neg.
Test directions	X, Y and Z axes
Extended testing: Monitoring of contact faults and interruptions	Passed
Extended testing: Voltage drop measurement before and after each axis	Passed
Vibration and shock stress for rolling stock equipment	Passed

### Commercial data

Product Group	1 (Rail Mounted Terminal Blocks)
PU (SPU)	5 pcs
Packaging type	Box
Country of origin	PL
GTIN	4044918452564
Customs tariff number	85369010000

### Product Classification

UNSPSC	39121410
eCl@ss 10.0	27-14-11-20
eCl@ss 9.0	27-14-11-20
ETIM 9.0	EC000897
ETIM 10.0	EC000897
ECCN	NO US CLASSIFICATION

### Environmental Product Compliance

RoHS Compliance Status	Compliant, No Exemption
------------------------	-------------------------

### Approvals / Certificates

#### General approvals



Approval	Standard	Certificate Name
CCA DEKRA Certification B.V.	EN 60947	NTR NL-7707
CSA CSA Group	C22.2	1151144
KEMA/KEUR DEKRA Certification B.V.	EN 60947	71-105562
UL Underwriters Laboratories Inc.	UL 1059	E45172

#### Declarations of conformity and manufacturer's declarations



Approval	Standard	Certificate Name
EU-Declaration of Confor- mity WAGO GmbH & Co. KG	-	-
Railway WAGO GmbH & Co. KG	-	Z00004420.000
UK-Declaration of Confor- mity WAGO GmbH & Co. KG	-	-

#### Approvals for marine applications



Approval	Standard	Certificate Name
ABS American Bureau of Ship- ping	EN 60947	24-0152298-PDA
BV Bureau Veritas S.A.	EN 60947	07436/G0 BV
DNV GL Det Norske Veritas, Ger- manischer Lloyd	-	TAE00001V2
LR Lloyds Register	EN 60947	LR23325966TA
PRS Polski Rejestr Statków	-	TE/1094/880590/23

### Downloads

#### Environmental Product Compliance

##### Compliance Search

Environmental Product Compliance 285-195	↓
---	---

### Documentation

#### Bid Text

285-195	19.02.2019	xml 3.23 KB	↓
285-195	04.01.2018	doc 23.50 KB	↓

CAD/CAE-Data

CAD data	CAE data
2D/3D Models 285-195	EPLAN Data Portal 285-195
	WSCAD Universe 285-195
	ZUKEN Portal 285-195

1 Compatible Products

1.1 Optional Accessories

1.1.1 Cover

1.1.1.1 Cover



**Item No.: 285-169**

Finger guard; touchproof cover protects unused conductor entries and jumper slots; for 95 mm² high-current tbs; yellow

1.1.2 Current and voltage tap

1.1.2.1 Current and voltage tap



**Item No.: 855-951/250-000**

Current and voltage tap up to 95 mm²; Primary rated current: 250 A; Secondary rated current: 1 A; Rated power: 0.2 VA; Accuracy class: 0.5; fused

1.1.3 DIN-rail

1.1.3.1 Mounting accessories



**Item No.: 210-198**

Copper carrier rail; 35 x 15 mm; 2.3 mm thick; 2 m long; unslotted; according to EN 60715; copper-colored



**Item No.: 210-508**

Steel carrier rail; 35 x 15 mm; 1.5 mm thick; 2 m long; slotted; galvanized; similar to EN 60715; silver-colored



**Item No.: 210-197**

Steel carrier rail; 35 x 15 mm; 1.5 mm thick; 2 m long; slotted; similar to EN 60715; silver-colored



**Item No.: 210-506**

Steel carrier rail; 35 x 15 mm; 1.5 mm thick; 2 m long; unslotted; galvanized; similar to EN 60715; silver-colored



**Item No.: 210-114**

Steel carrier rail; 35 x 15 mm; 1.5 mm thick; 2 m long; unslotted; similar to EN 60715; silver-colored

### 1.1.4 Ferrule

#### 1.1.4.1 Ferrule



**Item No.: 216-435**

Ferrule; Sleeve for 50 mm<sup>2</sup> / AWG 1; un-insulated; electro-tin plated; electrolytic copper; gastight crimped; acc. to DIN 46228, Part 1/08.92

### 1.1.5 Installation

#### 1.1.5.1 Mounting accessories



**Item No.: 285-168**

Fixing element; for 95 mm<sup>2</sup> high-current terminal blocks; orange



**Item No.: 249-197**

Screwless end stop; 14 mm wide; for DIN-rail 35 x 15 and 35 x 7.5; gray

### 1.1.6 Jumper

#### 1.1.6.1 Jumper



**Item No.: 285-495**

Jumper; insulated; gray

### 1.1.7 Marking

#### 1.1.7.1 Group marker carrier



**Item No.: 249-105**

Group marker carrier; gray

#### 1.1.7.2 Marker



**Item No.: 793-5501/000-006**

WMB marking card; as card; for terminal block width 5 - 17.5 mm; stretchable 5 - 5.2 mm; plain; snap-on type; blue



**Item No.: 793-5501/000-014**

WMB marking card; as card; for terminal block width 5 - 17.5 mm; stretchable 5 - 5.2 mm; plain; snap-on type; brown



**Item No.: 793-5501/000-007**

WMB marking card; as card; for terminal block width 5 - 17.5 mm; stretchable 5 - 5.2 mm; plain; snap-on type; green



**Item No.: 793-5501/000-023**

WMB marking card; as card; for terminal block width 5 - 17.5 mm; stretchable 5 - 5.2 mm; plain; snap-on type; green



**Item No.: 793-5501/000-017**

WMB marking card; as card; for terminal block width 5 - 17.5 mm; stretchable 5 - 5.2 mm; plain; snap-on type; light green



**Item No.: 793-5501/000-012**

WMB marking card; as card; for terminal block width 5 - 17.5 mm; stretchable 5 - 5.2 mm; plain; snap-on type; orange



**Item No.: 793-5501/000-005**

WMB marking card; as card; for terminal block width 5 - 17.5 mm; stretchable 5 - 5.2 mm; plain; snap-on type; red



**Item No.: 793-5501/000-024**

WMB marking card; as card; for terminal block width 5 - 17.5 mm; stretchable 5 - 5.2 mm; plain; snap-on type; violet



**Item No.: 793-5501**

WMB marking card; as card; for terminal block width 5 - 17.5 mm; stretchable 5 - 5.2 mm; plain; snap-on type; white



**Item No.: 793-5501/000-002**

WMB marking card; as card; for terminal block width 5 - 17.5 mm; stretchable 5 - 5.2 mm; plain; snap-on type; yellow



**Item No.: 793-501/000-006**

WMB marking card; as card; not stretchable; plain; snap-on type; blue



**Item No.: 793-501/000-007**

WMB marking card; as card; not stretchable; plain; snap-on type; gray

1.1.7.2 Marker



**Item No.: 793-501/000-023**

WMB marking card; as card; not stretchable; plain; snap-on type; green

**Item No.: 793-501/000-017**

WMB marking card; as card; not stretchable; plain; snap-on type; light green

**Item No.: 793-501/000-012**

WMB marking card; as card; not stretchable; plain; snap-on type; orange

**Item No.: 793-501/000-005**

WMB marking card; as card; not stretchable; plain; snap-on type; red



**Item No.: 793-501/000-024**

WMB marking card; as card; not stretchable; plain; snap-on type; violet

**Item No.: 793-501**

WMB marking card; as card; not stretchable; plain; snap-on type; white

**Item No.: 793-501/000-002**

WMB marking card; as card; not stretchable; plain; snap-on type; yellow

**Item No.: 2009-115/000-006**

WMB-Inline; for Smart Printer; 1500 pieces on roll; stretchable 5 - 5.2 mm; plain; snap-on type; blue



**Item No.: 2009-115/000-007**

WMB-Inline; for Smart Printer; 1500 pieces on roll; stretchable 5 - 5.2 mm; plain; snap-on type; gray

**Item No.: 2009-115/000-023**

WMB-Inline; for Smart Printer; 1500 pieces on roll; stretchable 5 - 5.2 mm; plain; snap-on type; green

**Item No.: 2009-115/000-017**

WMB-Inline; for Smart Printer; 1500 pieces on roll; stretchable 5 - 5.2 mm; plain; snap-on type; light green

**Item No.: 2009-115/000-012**

WMB-Inline; for Smart Printer; 1500 pieces on roll; stretchable 5 - 5.2 mm; plain; snap-on type; orange



**Item No.: 2009-115/000-005**

WMB-Inline; for Smart Printer; 1500 pieces on roll; stretchable 5 - 5.2 mm; plain; snap-on type; red

**Item No.: 2009-115/000-024**

WMB-Inline; for Smart Printer; 1500 pieces on roll; stretchable 5 - 5.2 mm; plain; snap-on type; violet

**Item No.: 2009-115**

WMB-Inline; for Smart Printer; 1500 pieces on roll; stretchable 5 - 5.2 mm; plain; snap-on type; white

**Item No.: 2009-115/000-002**

WMB-Inline; for Smart Printer; 1500 pieces on roll; stretchable 5 - 5.2 mm; plain; snap-on type; yellow

1.1.7.3 Marker carrier



**Item No.: 285-442**

Adaptor; gray

1.1.8 Power tap

1.1.8.1 Power tap



**Item No.: 285-407**

Power tap; for 95 mm<sup>2</sup> high-current tbs; gray

1.1.9 Protective warning marker

1.1.9.1 Cover



**Item No.: 285-170**

Protective warning marker; with high-voltage symbol; black; yellow

**Item No.: 285-175**

Protective warning marker; yellow

### 1.1.10 Tool

#### 1.1.10.1 Operating tool



**Item No.: 285-172**

Allen wrench; with a partially insulated shaft; green

**Item No.: 285-173**

Allen wrench; with a partially insulated shaft; with anti-rotation protection; green

### Installation Notes

#### Installation

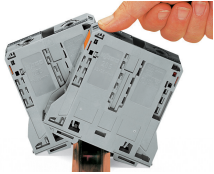

Snapping a terminal block onto DIN-rail (to the left or to the right).

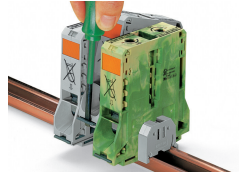

Removing a terminal block from the assembly (to the left or to the right).

### Conductor termination



For the optimal clamping force:

- Bend conductor
- Cut conductor to length (conductor end must be straight)
- Strip conductor



Always observe the on-unit printed strip length guide!

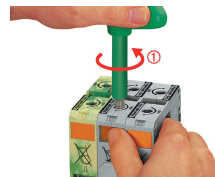

**Conductor termination – step 1:**  
Rotate the T-wrench counter-clockwise to the stop. Next, push in the orange locking tab. The clamp is locked open for hands-free wiring.

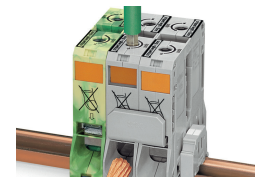

**Conductor termination – step 2:**  
Insert a stripped conductor into the clamping unit until it hits the backstop. Hold in this position.



**Conductor termination – step 3:**  
A short counter-clockwise rotation releases the tab. When unlocked, the T-wrench rotates clockwise, securely clamping the conductor.

### Commoning

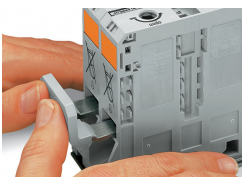

Commoning with an adjacent jumper: insert the jumper above the conductor entry hole – prior to conductor termination. The nominal cross-section remains unchanged.

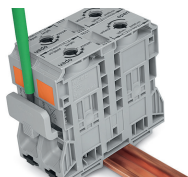

Removing jumper via operating tool.

Cover

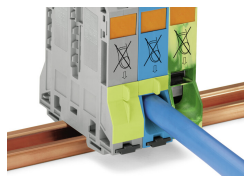

Protective warning marker may indicate:  
Notice: Power is still on even after switching off the main switch!

Yellow, detachable finger guards provide touch-proof safety by shielding jumper contact slots and/or unused conductor entries.

Power tap

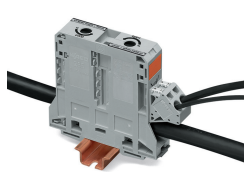
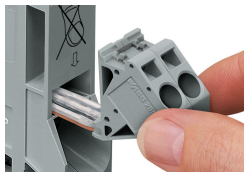

Easily and consistently tap directly into the power supply. Insert the unwired tap before opening the clamping unit.

The power taps enable the distribution of the L1, L2 and L3 potentials. The warning covers and finger guards ensure IP20 touch-proof protection.

Current and voltage tap

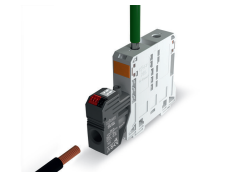
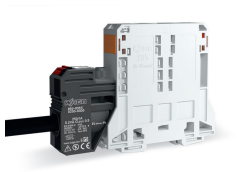

Installation via jumper slot

Feedthrough for primary conductors

Push-in CAGE CLAMP® connection technology

Integrated fuse

Security

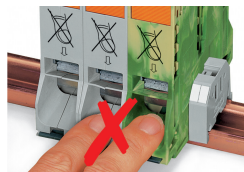

Risk of Injury!  
Do not insert fingers in the conductor entry!

Testing

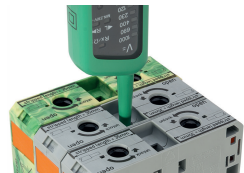
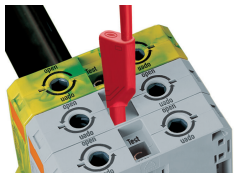

Testing via touch-proof 4 mm Ø test plugs (not available from WAGO, but offered by industry suppliers such as, Multi-Contact Deutschland GmbH).

Testing  
Voltage measurements can be performed, e.g., using a 2-pole voltage tester (Item No. 206-707).

Marking

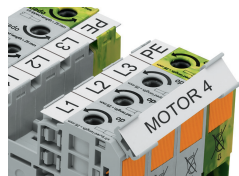
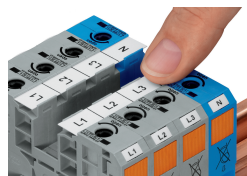

WMB markers or self-adhesive, printable marking strips can be accommodated on 35, 50 and 95 mm<sup>2</sup> high-current terminal blocks.

Marker carrier (Item No. 285-442) for marking strips (Item No. 2009-110) or 2 WMB markers for 285-13x, 285-15x and 285-19x Terminal Blocks