

大容量積層セラミックコンデンサ

HIGH VALUE MULTILAYER CERAMIC CAPACITORS

	code	Temp.characteristics	operating Temp. range
OPERATING TEMP.	BJ	B	-25~+85°C
		X7R	-55~+125°C
		X5R	-55~+85°C
	C	C	-25~+85°C
		X5S	-55~+85°C
		X6S	-55~+105°C
	E	E	-25~+85°C
		Y5U	-30~+85°C
	F	F	-25~+85°C
		Y5V	-30~+85°C

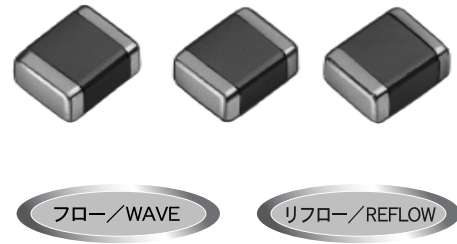

特長 FEATURES

- 電極にNi金属を使用し、端子電極部にメッキをしてあることにより、はんだ付け性および耐熱性にすぐれ、マイグレーションもほとんど発生せず、高い信頼性を示します
- 等価直列抵抗(ESR)が小さく、ノイズ吸収性にすぐれています。特にタンタルおよびアルミ電解コンデンサに比較した場合
- 高い許容リップル電流値
- 高い定格電圧でありながら小型形状
- 絶縁抵抗、破壊電圧が高く信頼性にすぐれる等の特徴があります

- The use of Nickel(Ni) as material for both the internal and external electrodes improves the solderability and heat resistance characteristics. This almost completely eliminates migration and raises the level of reliability significantly.
- Low equivalent series resistance(ESR) provides excellent noise absorption characteristics.
- Compared to tantalum or aluminum electrolytic capacitors these ceramic capacitors offer a number of excellent features, including:
 - Higher permissible ripple current values
 - Smaller case sizes relative to rated voltage
 - Improved reliability due to higher insulation resistance and breakdown voltage.

用途 APPLICATIONS

- デジタル回路全般
- 電源バイパスコンデンサ
液晶モジュール用
液晶駆動電圧ライン用
電源電圧の高いLSI、IC、OPアンプ用
- 平滑コンデンサ
DC-DCコンバータ(入力、出力側用)
スイッチング電源(2次側用)

- General digital circuit
- Power supply bypass capacitors
Liquid crystal modules
Liquid crystal drive voltage lines
LSI, IC, converters(both for input and output)
- Smoothing capacitors
DC-DC converters (both for input and output)
Switching power supplies (secondary side)

形名表記法 ORDERING CODE

1 定格電圧 (VDC)	3 端子電極	5 温度特性 (%)	7 容量許容差	9 個別仕様
A 4 J 6.3 L 10 E 16 T 25 G 35 U 50	K メッキ品	△F +30 -80 △C ±20 △E +20 -55 BJ ±10 △= スペース	K ±10 % M ±20 % Z +80 -20 %	- 標準
2 シリーズ名	4 形状寸法 (EIA)L×W(mm)	6 公称静電容量 (pF)	8 製品厚み (mm)	10 包装
M 積層コンデンサ	107(0603) 1.6×0.8 212(0805) 2.0×1.25 316(1206) 3.2×1.6 325(1210) 3.2×2.5 432(1812) 4.5×3.2	例 473 47,000 105 1,000,000	K 0.45 V 0.5 A 0.8 D 0.85 F 1.15 G 1.25 H 1.5 L 1.6 N 1.9 Y 2.0max M 2.5 U 3.2	B 単品(袋詰め) T リールテーピング
		6 Nominal capacitance(pF)		11 当社管理記号
		example 473 47,000 105 1,000,000		△ 標準品 △= スペース

J M K 3 1 6 B J 1 0 6 M L - T ○

1 Rated voltage(VDC)	3 End termination	5 Temperature characteristics code	7 Capacitance tolerances(%)	9 Special code
A 4 J 6.3 L 10 E 16 T 25 G 35 U 50	K Plated	△F Y5V -30~+85°C +22/-82% BJ X7R -55~+125°C ±15% BJ X5R -55~+85°C ±15% △C X5S -55~+85°C ±22% △C X6S -55~+105°C ±22% △E Y5U -30~+85°C ±22/-56% △=Blank space	K ±10 M ±20 Z +80 -20	- Standard products
2 Series name	4 Dimensions(case size)(mm)	6 Nominal capacitance(pF)	8 Thickness(mm)	10 Packaging
M Multilayer Ceramic Capacitors	107(0603) 1.6×0.8 212(0805) 2.0×1.25 316(1206) 3.2×1.6 325(1210) 3.2×2.5 432(1812) 4.5×3.2	example 473 47,000 105 1,000,000	K 0.45 V 0.5 A 0.8 D 0.85 F 1.15 G 1.25 H 1.5 L 1.6 N 1.9 Y 2.0max M 2.5 U 3.2	B Bulk T Tape & reel
				11 Internal code
				△ Standard products △=Blank space

アイテム一覧 PART NUMBERS

■107TYPE

定格電圧 Rated Voltage	形名 Ordering code	公称 静電容量 Capacitance [μF]	温度特性 Temperature characteristics	tan δ Dissipation factor [%]Max.	実装条件 Soldering method R:リフロー Soldering W:フロー Wave soldering	静電容量 許容差 Capacitance tolerance	厚み Thickness [mm]
35V	GMK107 BJ333□A	0.033	B/X5R	2.5	R/W	±10% ±20%	0.8±0.1
	GMK107 BJ473□A	0.047	B/X5R	2.5			0.8±0.1
25V	TMK107 BJ223□A	0.022	B/X7R	2.5			0.8±0.1
	TMK107 BJ683□A	0.068	B/X5R	3.5			0.8±0.1
	TMK107 BJ104□A	0.1	B/X5R	3.5			0.8±0.1
	TMK107 BJ105□A*	1	B/X5R	5			0.8±0.1
16V	EMK107 BJ333□A	0.033	B/X7R	3.5	R/W		0.8±0.1
	EMK107 BJ473□A	0.047	B/X7R	3.5			0.8±0.1
	EMK107 BJ683□A	0.068	B/X7R	3.5			0.8±0.1
	EMK107 BJ104□A	0.1	B/X7R	3.5			0.8±0.1
	EMK107 BJ154□A	0.15	B/X5R	3.5	R	0.8±0.1	
	EMK107 BJ224□A	0.22	B/X5R	3.5		0.8±0.1	
	EMK107 BJ474□A*	0.47	B/X5R	3.5		0.8±0.1	
	EMK107 BJ105□A*	1	B/X5R	5		0.8±0.1	
10V	LМК107 BJ334□A	0.33	B/X5R	3.5	R/W	0.8±0.1	
	LМК107 BJ474□A	0.47	B/X5R	3.5		0.8±0.1	
	LМК107 BJ684□A	0.68	B/X5R	5	R	0.8±0.1	
	LМК107 BJ105□A*	1	B/X7R	5		0.8±0.1	
	LМК107 BJ225□A*	2.2	B/X5R	10		0.8±0.1	
6.3V	JMK107 BJ474□K	0.47	B/X5R	5	R	0.45±0.05	
	JMK107 BJ105□K*	1	B/X5R	10		0.45±0.05	
	JMK107 BJ225□A*	2.2	B/X5R	10		0.8±0.1	
	JMK107 BJ335□A*	3.3	X5R	10		0.8±0.1	
	JMK107 BJ475MA*	4.7	X5R	10		±20% 0.8±0.1	
	4V	AMK107 BJ225□V*	2.2	X5R		10	±10% ±20%
50V	UMK107 C105□A	1	C/X5S	10	R/W	0.8±0.1	
	UMK107 F104ZA	0.1	F/Y5V	7		0.8±0.1	
16V	EMK107 F224ZA	0.22	F/Y5V	7		R	0.8±0.1
	EMK107 F474ZA	0.47	F/Y5V	7			0.8±0.1
	EMK107 F105ZA*	1	F/Y5V	16	R	0.8±0.1	
	EMK107 F225ZA*	2.2	F/Y5V	16		0.8±0.1	
10V	LМК107 F105ZA	1	F/Y5V	16	R	0.8±0.1	
	LМК107 F225ZA	2.2	F/Y5V	16		0.8±0.1	
6.3	JMK107 F105ZK	1	F/Y5V	16		0.45±0.05	

形名の□には静電容量許容差記号が入ります。 □ Please specify the capacitance tolerance code.

*高温負荷試験の試験電圧は定格電圧の1.5倍

* Test Voltage of Loading at high temperature test is 1.5 time of the rated voltage.

■212TYPE

定格電圧 Rated Voltage	形名 Ordering code	公称 静電容量 Capacitance [μF]	温度特性 Temperature characteristics	tan δ Dissipation factor [%]Max.	実装条件 Soldering method R:リフロー Reflow soldering W:フロー Wave soldering	静電容量 許容差 Capacitance tolerance	厚み Thickness [mm]
50V	UMK212 BJ223□D	0.022	B/X7R	2.5	R/W	±10% ±20%	0.85±0.1
	UMK212 BJ333□D	0.033	B/X7R	2.5			0.85±0.1
	UMK212 BJ473□G	0.047	B/X7R	2.5			1.25±0.1
	UMK212 BJ683□G	0.068	B/X7R	2.5			1.25±0.1
	UMK212 BJ104□G	0.1	B/X7R	2.5			1.25±0.1
	UMK212 BJ154□G	0.15	B/X7R	3.5			1.25±0.1
35V	UMK212 BJ224□G	0.22	B/X5R	3.5	R	1.25±0.1	
	GМК212 BJ334□G	0.33	B/X7R	3.5		1.25±0.1	
25V	GМК212 BJ474□G	0.47	B/X5R	3.5	R/W	1.25±0.1	
	TMK212 BJ473□D	0.047	B/X7R	2.5		0.85±0.1	
	TMK212 BJ683□D	0.068	B/X7R	2.5		0.85±0.1	
16V	TMK212 BJ474□D	0.47	B/X5R	3.5	R	0.85±0.1	
	TMK212 BJ105□G	1	B/X5R	5		1.25±0.1	
	EMK212 BJ474□D	0.47	B/X7R	3.5		0.85±0.1	
	10V	EMK212 BJ684□D	0.68	B/X7R	3.5	R/W	0.85±0.1
		EMK212 BJ105□D	1	B/X5R	5		0.85±0.1
		EMK212 BJ155□D	1.5	B/X5R	5	R	0.85±0.1
		EMK212 BJ225□D*	2.2	B/X5R	5		0.85±0.1
		EMK212 BJ684□G	0.68	B/X7R	3.5	R/W	1.25±0.1
		EMK212 BJ105□G	1	B/X7R	3.5		1.25±0.1
EMK212 BJ225□G		2.2	B/X5R	5	R	1.25±0.1	
EMK212 BJ475□G*		4.7	B/X5R	5		1.25±0.15	
6.3V	LMK212 BJ224□K	0.22	B/X5R	3.5	R	0.45±0.05	
	LMK212 BJ105□D	1	B/X7R	3.5		0.85±0.1	
	LMK212 BJ225□D*	2.2	B/X5R	5		0.85±0.1	
	10V	LMK212 BJ475□D*	4.7	B/X5R	7.5	R/W	0.85±0.1
		LMK212 BJ105□G	1	B/X7R	3.5		1.25±0.1
		LMK212 BJ225□G	2.2	B/X7R	5	R	1.25±0.1
		LMK212 BJ335□G	3.3	B/X5R	5		1.25±0.1
		LMK212 BJ475□G*	4.7	B/X5R	5		1.25±0.15
		LMK212 BJ106□G*	10	B/X5R	10		1.25±0.15
		JMK212 BJ105□K	1	B/X5R	5		0.45±0.05
6.3V	JMK212 BJ475□D*	4.7	B/X5R	10	0.85±0.1		
	JMK212 BJ106□D*	10	X5R	10	0.85±0.1		
	JMK212 BJ475□G	4.7	B/X5R	5	1.25±0.15		
	JMK212 BJ106□G*	10	B/X5R	10	1.25±0.15		
	JMK212 BJ226MG*	22	X5R	10	1.25±0.15		
10V	LMK212 C106□G*	10	C/X5S	10	R/W	1.25±0.1	
	UMK212 F224ZD	0.22	F/Y5V	7		0.85±0.1	
50V	UMK212 F474ZG	0.47	F/Y5V	7	R/W	1.25±0.1	
	UMK212 F105ZG	1	F/Y5V	7		1.25±0.1	
	EMK212 F225ZG	2.2	F/Y5V	7		1.25±0.1	
16V	LMK212 F225ZD	2.2	F/Y5V	9	R	0.85±0.1	
	LMK212 F475ZG	4.7	F/Y5V	9		1.25±0.1	
10V	LMK212 F106ZG	10	F/Y5V	16	R	1.25±0.1	
	JMK212 F475ZD	4.7	F/Y5V	16		0.85±0.1	
6.3V	JMK212 F106ZG	10	F/Y5V	16	R	1.25±0.1	

形名の□には静電容量許容差記号が入ります。

□ Please specify the capacitance tolerance code.

*高温負荷試験の試験電圧は定格電圧の1.5倍

* Test Voltage of Loading at high temperature test is 1.5 time of the rated voltage.

アイテム一覧 PART NUMBERS

■316TYPE

定格電圧 Rated Voltage	形名 Ordering code	公称静電容量 Capacitance [μF]	温度特性 Temperature characteristics	tan δ Dissipation factor [%]Max.	実装条件 Soldering method R:リフロー Reflow soldering W:7口 Wave soldering	静電容量許容差 Capacitance tolerance	厚み Thickness [mm]	
50V	UMK316 BJ154□F	0.15	B/X7R	2.5	R/W	±10% ±20%	1.15±0.1	
	UMK316 BJ224□L	0.22	B/X7R	2.5			1.6±0.2	
	UMK316 BJ474□L	0.47	B/X7R	3.5			1.6±0.2	
35V	GMK316 BJ684□L	0.68	B/X7R	3.5			1.6±0.2	
	GMK316 BJ105□L	1	B/X7R	3.5			1.6±0.2	
25V	TMK316 BJ154□D	0.15	B/X7R	2.5			R	0.85±0.1
	TMK316 BJ224□F	0.22	B/X7R	2.5				1.15±0.1
	TMK316 BJ334□F	0.33	B/X7R	2.5				1.15±0.1
	TMK316 BJ684□L	0.68	B/X7R	3.5				1.6±0.2
	TMK316 BJ105□D	1	B/X5R	3.5				0.85±0.1
	TMK316 BJ225□L	2.2	B/X7R	3.5				1.6±0.2
	TMK316 BJ335□L	3.3	B/X5R	3.5				1.6±0.2
	TMK316 BJ475□L*	4.7	B/X5R	5	1.6±0.2			
16V	EMK316 BJ106□L*	10	B/X5R	5	R/W	1.6±0.2		
	EMK316 BJ155□D	1.5	B/X5R	3.5		0.85±0.1		
	EMK316 BJ225□D	2.2	B/X5R	3.5		0.85±0.1		
	EMK316 BJ684□F	0.68	B/X7R	3.5		1.15±0.1		
	EMK316 BJ105□F	1	B/X7R	3.5		1.15±0.1		
	EMK316 BJ225□L	2.2	B/X7R	3.5		1.6±0.2		
	EMK316 BJ335□L	3.3	B/X7R	3.5		1.6±0.2		
10V	EMK316 BJ475□L	4.7	B/X5R	5	R	1.6±0.2		
	EMK316 BJ106□L*	10	B/X5R	5		1.6±0.2		
	LMK316 BJ335□D	3.3	B/X5R	5		0.85±0.1		
	LMK316 BJ475□D	4.7	B/X5R	5		0.85±0.1		
	LMK316 BJ106□D*	10	B/X5R	10		0.85±0.1		
	LMK316 BJ335□L	3.3	B/X7R	3.5		1.6±0.2		
	LMK316 BJ475□L	4.7	B/X7R	5		1.6±0.2		
6.3V	LMK316 BJ106□L*	10	B/X5R	5	R	1.6±0.2		
	LMK316 BJ226ML*	22	B/X5R	10		±20%		
	JMK316 BJ685□F	6.8	B/X5R	10		±10%		
	JMK316 BJ106□D*	10	B/X5R	10		±20%		
	JMK316 BJ106□L	10	B/X7R	5		1.6±0.2		
4V	JMK316 BJ226ML*	22	B/X5R	10	R/W	±20%		
	AMK316 BJ476ML*	47	X5R	10		1.6±0.2		
25V	TMK316 C106□L	10	C/X5S	10		±10% ±20%		
50V	UMK316 F225ZG	2.2	F/Y5V	7	R/W			
35V	GMK316 F475ZG	4.7	F/Y5V	7	R	±80% -20%		
25V	TMK316 F106ZL	10	F/Y5V	9		1.25±0.1		
16V	EMK316 F106ZL	10	F/Y5V	9		1.6±0.2		
10V	LMK316 F475ZD	4.7	F/Y5V	9		1.6±0.2		
	LMK316 F106ZF	10	F/Y5V	9		0.85±0.1		
	LMK316 F226ZL	22	F/Y5V	16		1.15±0.1		
6.3V	JMK316 F106ZD	10	F/Y5V	16			1.6±0.2	
								0.85±0.1

形名の□には静電容量許容差記号が入ります。 □ Please specify the capacitance tolerance code.

*高温負荷試験の試験電圧は定格電圧の1.5倍

* Test Voltage of Loading at high temperature test is 1.5 time of the rated voltage.

アイテム一覧 PART NUMBERS

■325TYPE

定格電圧 Rated Voltage	形名 Ordering code	公称静電容量 Capacitance [μF]	温度特性 Temperature characteristics	tan δ Dissipation factor [%]Max.	実装条件 Soldering method R:リフロー Reflow soldering W:フロー Wave soldering	静電容量許容差 Capacitance tolerance	厚み Thickness [mm]
50V	UMK325 BJ105□H	1	B/X7R	3.5	R/W	±10%±20%	1.5±0.1
35V	GMK325 BJ225MN	2.2	B/X5R	3.5	R	±20%	1.9±0.2
25V	TMK325 BJ105MD	1	B/X7R	3.5			0.85±0.1
	TMK325 BJ225MH	2.2	B/X7R	3.5			1.5±0.1
	TMK325 BJ335MN	3.3	B/X7R	3.5			1.9±0.2
	TMK325 BJ475MN	4.7	B/X5R	3.5			1.9±0.2
	TMK325 BJ106MM*	10	B/X5R	3.5			2.5±0.2
	TMK325 BJ106MY	10	B/X5R	5			1.9+0.1/-0.2
16V	EMK325 BJ475MN	4.7	B/X7R	3.5			1.9±0.2
	EMK325 BJ106MD*	10	B/X5R	3.5			0.85±0.1
	EMK325 BJ106MN	10	B/X5R	5			1.9±0.2
	EMK325 BJ226MM*	22	B/X5R	5			2.5±0.2
10V	LMK325 BJ335MD	3.3	B/X5R	3.5			0.85±0.1
	LMK325 BJ106MN	10	B/X7R	3.5			1.9±0.2
	LMK325 BJ475MD	4.7	B/X5R	5			0.85±0.1
	LMK325 BJ106MD*	10	B/X5R	5			0.85±0.1
	LMK325 BJ226MY*	22	B/X5R	5			1.9+0.1/-0.2
	LMK325 BJ226MM*	22	B/X5R	5			2.5±0.2
6.3V	LMK325 BJ476MM*	47	B/X5R	10			2.5±0.2
	JMK325 BJ685MD	6.8	B/X5R	5			0.85±0.1
	JMK325 BJ226MY	22	B/X5R	5			1.9+0.1/-0.2
	JMK325 BJ476MM*	47	B/X5R	10			2.5±0.2
	JMK325 BJ826MN*	82	X5R	10			1.9±0.2
	JMK325 BJ107MM*	100	X5R	10			2.5±0.3
50V	JMK325 E826ZY*	82	E/Y5U	16	1.9+0.1/-0.2		
	JMK325 E107ZM*	100	E/Y5U	16	2.5±0.2		
	UMK325 F475ZH	4.7	F/Y5V	9	1.5±0.1		
	35V	GMK325 F106ZH	10	F/Y5V	7	1.5±0.1	
	10V	LMK325 F226ZN	22	F/Y5V	16	1.9±0.2	
		LMK325 F106ZF	10	F/Y5V	16	1.15±0.1	
	6.3V	JMK325 F476ZN	47	F/Y5V	16	1.9±0.2	
		JMK325 F107ZM*	100	F/Y5V	16	2.5±0.2	

■432TYPE

定格電圧 Rated Voltage	形名 Ordering code	公称静電容量 Capacitance [μF]	温度特性 Temperature characteristics	tan δ Dissipation factor [%]Max.	実装条件 Soldering method R:リフロー Reflow soldering W:フロー Wave soldering	静電容量許容差 Capacitance tolerance	厚み Thickness [mm]
25V	TMK432 BJ106MM	10	B/X5R	3.5	R	±20%	2.5±0.2
16V	EMK432 BJ226MM*	22	B/X5R	3.5			2.5±0.2
10V	LMK432 BJ226MM	22	B/X5R	3.5			2.5±0.2
6.3V	JMK432 BJ476MM*	47	B/X5R	5			2.5±0.2
	JMK432 BJ107MU*	100	B/X5R	10			3.2±0.3
50V	UMK432 C106MM*	10	C/X5S	5			2.5±0.2
	TMK432 C226MM*	22	C/X5S	5			2.5±0.2
25V	TMK432 C476MM*	47	C/X5S	5			2.5±0.2
	JMK432 C107MM*	100	C/X6S	7			2.5±0.2
6.3V	JMK432 C107MY*	100	C/X5S	10			1.9+0.1/-0.2
	10V	LMK432 F476ZM*	47	F/Y5V			16
6.3V	JMK432 F107ZM*	100	F/Y5V	16			2.5±0.2

形名の□には静電容量許容差記号が入ります。 □ Please specify the capacitance tolerance code.

*高温負荷試験の試験電圧は定格電圧の1.5倍

* Test Voltage of Loading at high temperature test is 1.5 time of the rated voltage.

特性図 ELECTRICAL CHARACTERISTICS

インピーダンス・ESR-周波数特性例 Example of Impedance ESR vs. Frequency characteristics
 ・当社積層セラミックコンデンサ例 (Taiyo Yuden multilayer ceramic capacitor)

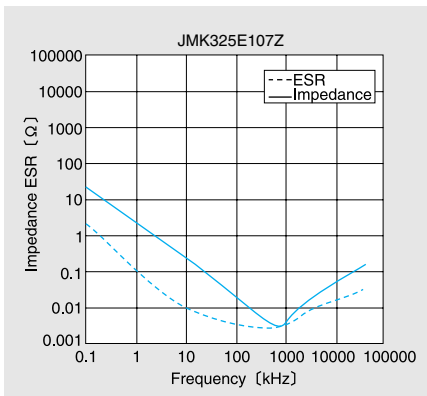
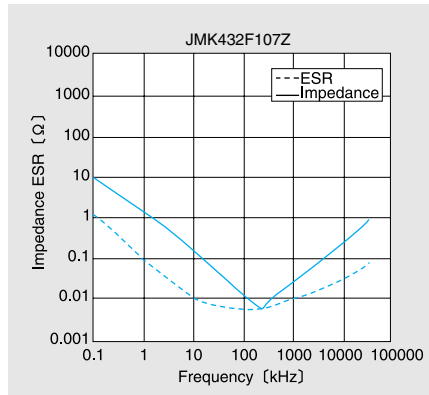
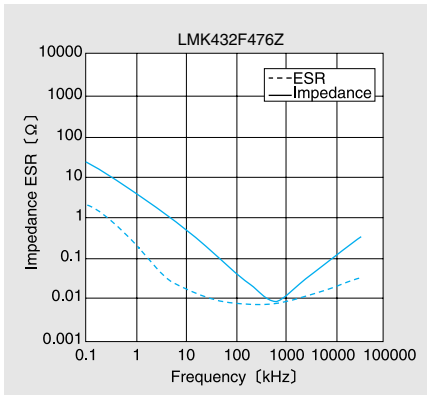
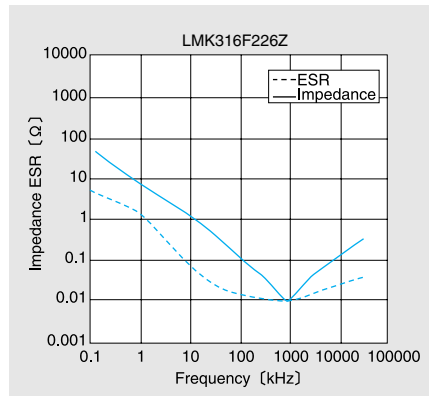
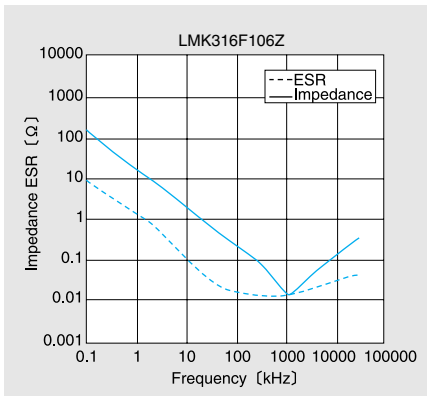
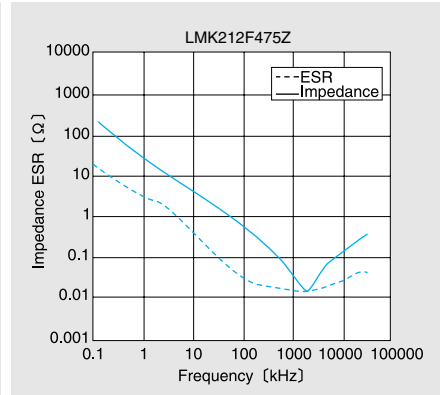
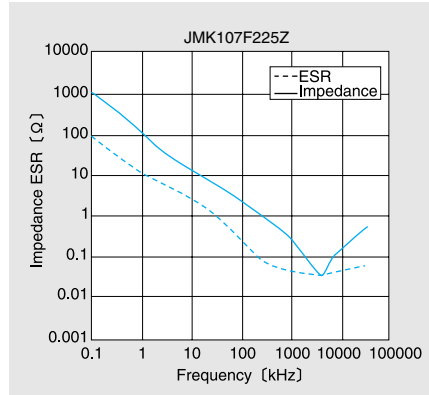
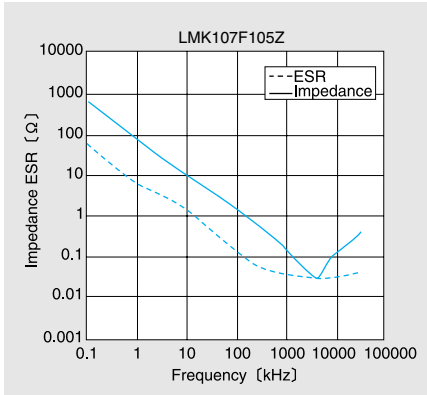

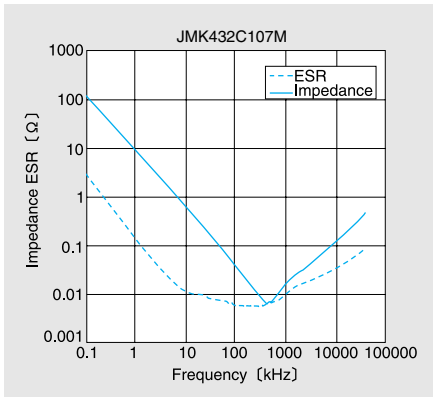
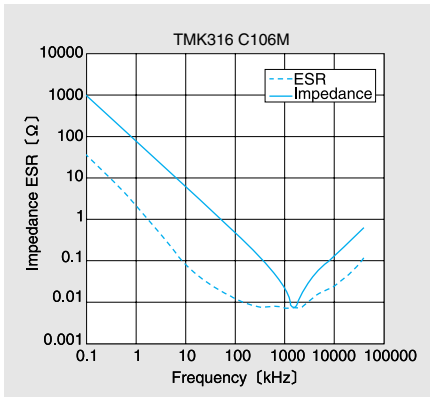
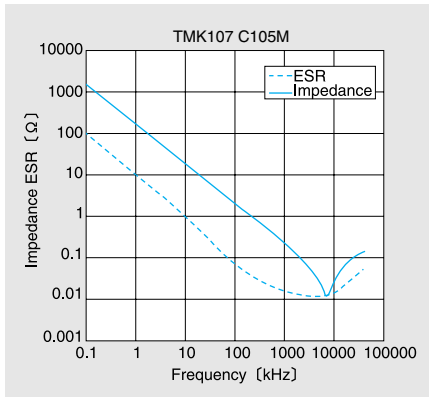
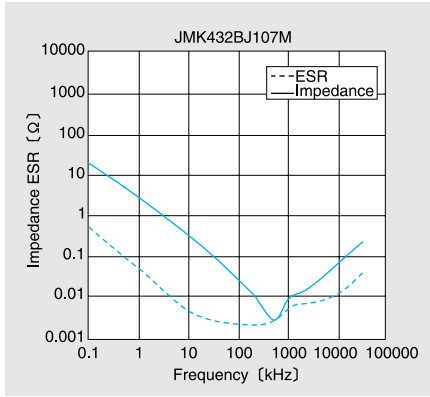
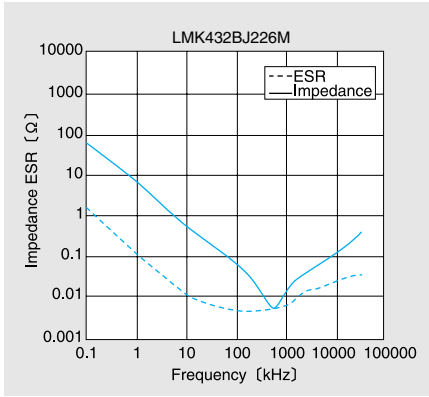
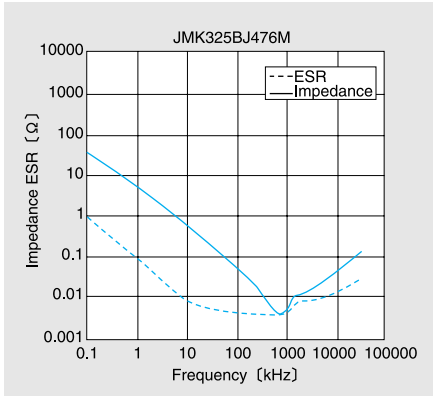
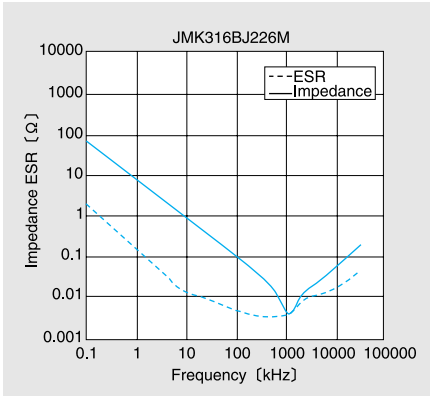
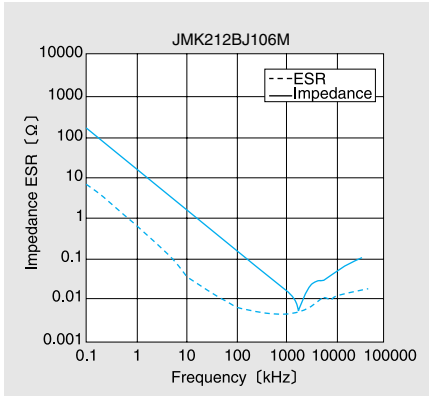
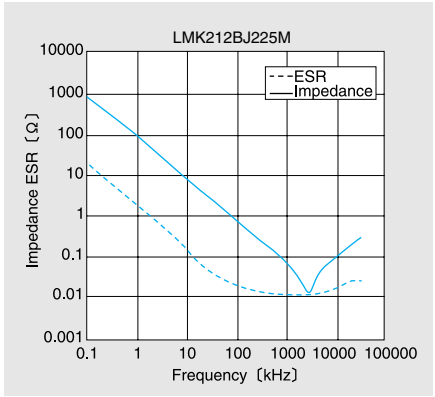
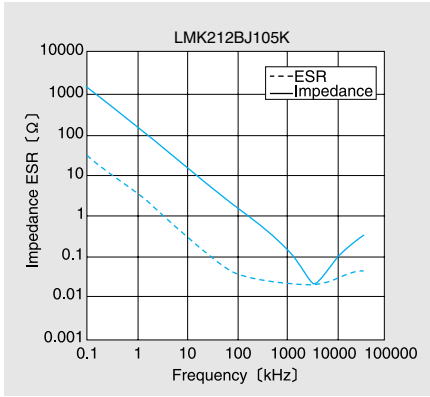
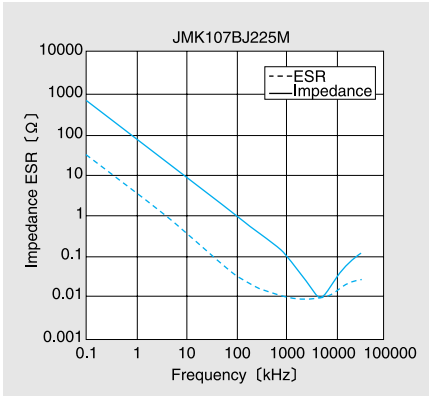

一般積層セラミックコンデンサ (温度補償用・Class 1) STANDARD MULTILAYER CERAMIC CAPACITORS (CLASS1 : TEMPERATURE COMPENSATING DIELECTRIC TYPE)

OPERATING TEMP. -55~+125°C

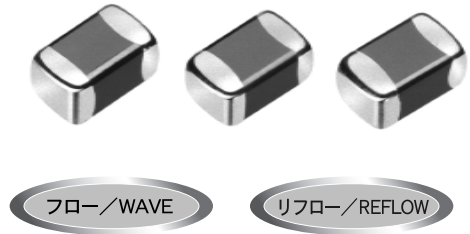

特長 FEATURES

- ・実装密度の向上が図れます
- ・モノリシックの構造のため、信頼性が高い
- ・同一形状、静電容量範囲が広い

- ・ Improve Higher Mounting Densities.
- ・ Multilayer block structure provides higher reliability
- ・ A wide range of capacitance values available in standard case sizes.

用途 APPLICATIONS

- ・一般電子機器用
- ・通信機器用 (携帯電話、PHS、コードレス電話 etc.)

- ・ General electronic equipment
- ・ Communication equipment (portable telephones, PHS, other wireless applications, etc.)

形名表記法 ORDERING CODE

1 定格電圧 (VDC)	4 形状寸法 (EIA) L×W (mm)	6 公称静電容量 (pF)	7 容量許容差	9 個別仕様
E 16 T 25 U 50	063(0201) 0.6×0.3 105(0402) 1.0×0.5 107(0603) 1.6×0.8	例 0R5 0.5 010 1 100 10 ※R= 小数点	C ± 0.25 pF D ± 0.5 pF F ± 1 pF J ± 5 % K ± 10 %	— 標準
2 シリーズ名	5 温度特性 (ppm/°C)	8 製品厚み (mm)	10 包装	11 当社管理記号
M 積層コンデンサ	C□ 0 : CG, CH, CJ, CK P□ -150 : PH, PJ, PK R□ -220 : RH, RJ, RK S□ -330 : SH, SJ, SK G ± 30 T□ -470 : TH, TJ, TK H ± 60 U□ -750 : UJ, UK J ± 120 S L +350~+1000 K ± 250 □=許容差	P 0.3 V 0.5 W 0.5 Z 0.8	B 単品(袋詰め) F テーピング(2mmピッチ・178φ) T テーピング(4mmピッチ・178φ)	△ 標準品 △=スペース

U M K 1 0 5 C H 1 0 1 J W - F ○

1 Rated voltage (VDC)	4 Dimensions (case size) (EIA) L×W (mm)	6 Nominal Capacitance (pF)	7 Capacitance Tolerance	9 Special code
E 16 T 25 U 50	063(0201) 0.6×0.3 105(0402) 1.0×0.5 107(0603) 1.6×0.8	example 0R5 0.5 010 1 100 10 *R=decimal point	C ± 0.25 pF D ± 0.5 pF F ± 1 pF J ± 5 % K ± 10 %	— Standard Products
2 Series name	5 Temperature characteristics (ppm/°C)	8 Thickness (mm)	10 Packaging	11 Internal code
M Multilayer ceramic capacitor	C□ 0 : CG, CH, CJ, CK (C0G, C0H, C0J, C0K) P□ -150 : PH, PJ, PK (P2H, P2J, P2K) R□ -220 : RH, RJ, RK (R2H, R2J, R2K) S□ -330 : SH, SJ, SK (S2H, S2J, S2K) 2 ± 30 T□ -470 : TH, TJ, TK (T2H, T2J, T2K) H ± 60 U□ -750 : UJ, UK (U2J, U2K) 2J ± 120 S L +350~+1000 K ± 250 □=Temperature	P 0.3 V 0.5 W 0.5 Z 0.8	B Bulk F Tape(2mm pitch・178φ) T Tape(4mm pitch・178φ)	△ Standard Products △=Blank space

外形寸法 EXTERNAL DIMENSIONS

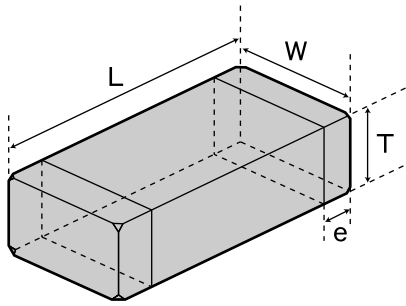

Type (EIA)	L	W	T		e
□MK063 (0201)	0.6±0.03 (0.024±0.001)	0.3±0.03 (0.012±0.001)	0.3±0.03 (0.012±0.001)	P	0.15±0.05 (0.006±0.002)
□MK105 (0402)	1.0±0.05 (0.039±0.002)	0.5±0.05 (0.020±0.002)	0.5±0.05 (0.020±0.002)	W	0.25±0.10 (0.010±0.004)
□MK107 (0603)	1.6±0.10 (0.063±0.004)	0.8±0.10 (0.031±0.004)	0.8±0.10 (0.031±0.004)	Z	0.35±0.25 (0.014±0.010)

Unit : mm(inch)

概略バリエーション AVAILABLE CAPACITANCE RANGE

Type	063							105				107			
Temp.char.	C□	R□	S□	T□	U□	C□	SL	C□	FC,TC,RC,SC	U□	SL	C□	FC,TC,RC,SC	U□	SL
WV	25V		16V		50V		50V								
[pF]	[pF 3digits]														
0.5	OR5														
1	010														
1.5	1R5														
2	020														
3	030														
4	040														
5	050														
6	060	P													
7	070														
8	080														
9	090	W													
10	100														
12	120														
15	150														
18	180														
22	220														
27	270														
33	330														
39	390														
47	470														
56	560														
68	680														
82	820					V	V								
100	101														
120	121														
150	151														
180	181														
220	221														
270	271														
330	331														
390	391														
470	471														
560	561														
680	681														
820	821														
1000	102														

注：グラフの記号は製品の厚み記号です。
Note: Letter code in shaded areas are thickness codes.

温度特性 Temperature Characteristics

温度特性 Temperature char.(EIA)	温度係数範囲 [ppm/C] ※1 Temperature coefficient range	使用温度範囲 Operating Temp. range
C K(C0K)	0±250	-55~+125℃
C J(C0J)	0±120	
C H(C0H)	0±60	
C G(C0G)	0±30	
P K(P2K)	-150±250	
P J(P2J)	-150±120	
P H(P2H)	-150±60	
R K(R2K)	-220±250	
R J(R2J)	-220±120	
R H(R2H)	-220±60	
S K(S2K)	-330±250	
S J(S2J)	-330±120	
S H(S2H)	-330±60	
T K(T2K)	-470±250	
T J(T2J)	-470±120	
T H(T2H)	-470±60	
U K(U2K)	-750±250	
U J(U2J)	-750±120	
S L	-1000~+350	

※1：20℃における静電容量を基準。
Based on the capacitance at 20℃

静電容量許容差 Capacitance Tolerance Symbol

記号 Symbol	許容差 Tolerance	区分 Item
C	±0.25pF	~5pF
D	±0.5 pF	~10pF
F	±1pF	6~10 pF
J	±5 %	11pF~
K	±10 %	11pF~

Q

Q※2 Symbol	区分 Item
≥400+20・C※1	~27pF
≥1000	30pF~

※1：C=公称静電容量 Nominal capacitance(pF)

※2：測定周波数 Measurement Frequency= 1±0.1MHz(C≤1000pF)
1±0.1kHz (C>1000pF)

測定電圧 Measurement voltage = 0.5~5Vrms(C≤1000pF)
1±0.2Vrms(C>1000pF)

セレクションガイド
Selection Guide

アイテム一覧
Part Numbers

特性図
Electrical Characteristics

梱包
Packaging

信頼性
Reliability Data

使用上の注意
Precautions



etc

063TYPE

Class 1

定格電圧 Rated Voltage (DC)	形名 Ordering code	温度特性 Temperature characteristics (EIA)														公称静電容量 Capacitance [pF]	静電容量許容差 Capacitance tolerance [%]	厚み Thickness [mm] (inch)					
		CK (CK)	CJ (CJ)	CH (CH)	CG (CG)	PK (PK)	PJ (PJ)	PH (PH)	RK (RK)	RJ (RJ)	RH (RH)	SK (SK)	SJ (SJ)	SH (SH)	TK (TK)				TJ (TJ)	TH (TH)	UK (UK)	UJ (UJ)	SL
25V	TMK063 CK0R5□P	●																			0.5	±0.25pF	0.3±0.03 (0.012±0.001)
	TMK063 CK010□P	●																			1		
	TMK063 CK1R5□P	●																			1.5		
	TMK063 CK020□P	●																			2		
	TMK063 CJ030□P		●																		3		
	TMK063 CH040□P			●																	4		
	TMK063 CH050□P			●																	5		
	TMK063 CH060□P			●																	6		
	TMK063 CH070□P			●																	7		
	TMK063 CH080□P			●																	8		
	TMK063 CH090□P			●																	9		
	TMK063 CH100□P			●																	10		
	TMK063 CH120□P			●																	12		
	TMK063 CH150□P			●																	15		
	TMK063 CH180□P			●																	18		
	TMK063 CH220□P			●																	22		
	TMK063 CH270□P			●																	27		
	TMK063 CH330□P			●																	33		
	TMK063 CH390□P			●																	39		
	TMK063 CH470□P			●																	47		
TMK063 CH560□P			●																	56			
TMK063 CH680□P			●																	68			
TMK063 CH820□P			●																	82			
TMK063 CH101□P			●																	100			

注：形名の□には静電容量許容差記号が入ります。
△ Please specify the capacitance tolerance code.

105TYPE

Class 1

定格電圧 Rated Voltage (DC)	形名 Ordering code	温度特性 Temperature characteristics (EIA)														公称静電容量 Capacitance [pF]	静電容量許容差 Capacitance tolerance [%]	厚み Thickness [mm] (inch)					
		CK (CK)	CJ (CJ)	CH (CH)	CG (CG)	PK (PK)	PJ (PJ)	PH (PH)	RK (RK)	RJ (RJ)	RH (RH)	SK (SK)	SJ (SJ)	SH (SH)	TK (TK)				TJ (TJ)	TH (TH)	UK (UK)	UJ (UJ)	SL
50V	UMK105 △ 0R5□W	●																●			0.5	±0.25pF	0.5±0.05 (0.020±0.002)
	UMK105 △ 010□W	●																●			1		
	UMK105 △ 1R5□W	●																●			1.5		
	UMK105 △ 020□W	●																●			2		
	UMK105 △ 030□W		●															●			3		
	UMK105 △ 040□W			●														●			4		
	UMK105 △ 050□W			●														●			5		
	UMK105 △ 060□W			●														●			6		
	UMK105 △ 070□W			●														●			7		
	UMK105 △ 080□W			●														●			8		
	UMK105 △ 090□W			●														●			9		
	UMK105 △ 100□W			●														●			10		
	UMK105 △ 120□W			●														●			12		
	UMK105 △ 150□W			●														●			15		
	UMK105 △ 180□W			●														●			18		
	UMK105 △ 220□V			●														●			22		
	UMK105 △ 270□V			●														●			27		
	UMK105 △ 330□V			●														●			33		
	UMK105 △ 390□V			●														●			39		
	UMK105 △ 470□V			●														●			47		
	UMK105 △ 560□V			●														●			56		
	UMK105 △ 680□V			●														●			68		
	UMK105 △ 820□V			●														●			82		
	UMK105 △ 101□V			●														●			100		
	UMK105 △ 121□V			●														●			120		
	UMK105 △ 151□V			●														●			150		
	UMK105 △ 181□V			●														●			180		
	UMK105 △ 221□V			●														●			220		
	UMK105 △ 271□V			●														●			270		
	UMK105 UJ331□V			●														●			330		
UMK105 SL121□V																		●		120			
UMK105 SL151□V																		●		150			
UMK105 SL181□V																		●		180			
UMK105 SL221□V																		●		220			
UMK105 SL271□V																		●		270			
UMK105 SL331□V																		●		330			

注：形名の△には温度特性、□には静電容量許容差記号が入ります。
△ Please specify the temperature characteristics code and □ the capacitance tolerance code.

105TYPE

Class 1

定格電圧 Rated Voltage (DC)	形名 Ordering code	温度特性 Temperature characteristics (EIA)														公称静電容量 Capacitance [pF]	静電容量許容差 Capacitance tolerance [%]	厚み Thickness [mm] (inch)					
		CK (CK)	CJ (CJ)	CH (CH)	CG (CG)	PK (PK)	PJ (PJ)	PH (PH)	FK (FK)	FJ (FJ)	FH (FH)	SK (SK)	SJ (SJ)	SH (SH)	TK (TK)				TJ (TJ)	TH (TH)	UK (UK)	UJ (UJ)	SL
16V	EMK105 △ 0R5BW										●			●							0.5	±0.1pF	0.5±0.05 (0.020±0.002)
	EMK105 △ 010BW										●			●							1		
	EMK105 △ 1R2BW										●			●							1.2		
	EMK105 △ 1R5BW										●			●							1.5		
	EMK105 △ 1R8BW										●			●							1.8		
	EMK105 △ 2R2JW										●			●							2.2		
	EMK105 △ 2R7JW										●			●							2.7		
	EMK105 △ 3R3JW											●	●	●							3.3		
	EMK105 △ 3R9JW												●	●	●						3.9		
	EMK105 △ 4R7JW													●	●	●					4.7		
	EMK105 △ 5R6JW										●			●	●	●					5.6		
	EMK105 △ 6R8JW										●			●	●	●					6.8		
	EMK105 △ 8R2JW										●			●	●	●					8.2		
	EMK105 △ 100JW										●			●	●	●					10		
	EMK105 △ 120JW										●			●	●	●					12		
	EMK105 △ 150JW										●			●	●	●					15		
	EMK105 △ 180JW										●			●	●	●					18		
EMK105 △ 200JW										●			●	●	●					20			

注：形名の△には温度特性、□には静電容量許容差記号が入ります。
 △ Please specify the temperature characteristics code and □ the capacitance tolerance code.

一般積層セラミックコンデンサ

(高誘電率系・Class 2)

STANDARD MULTILAYER CERAMIC CAPACITORS

(CLASS2 :HIGH DIELECTRIC CONSTANT TYPE)

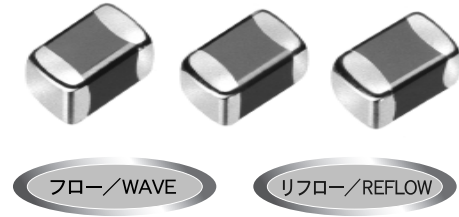

	code	Temp.characteristics	operating Temp. range
OPERATING TEMP.	B/BJ	B	-25~+85°C
		X7R	-55~+125°C
		X5R	-55~+85°C
	F	F	-25~+85°C
		Y5V	-30~+85°C

特長 FEATURES

- 実装密度の向上が図れます
- モノリシックの構造のため、信頼性が高い
- 同一形状、静電容量範囲が広い

- Improve Higher Mounting Densities.
- Multilayer block structure provides higher reliability
- A wide range of capacitance values available in standard case sizes.

用途 APPLICATIONS

- 一般電子機器用
- 通信機器用 (携帯電話、PHS、コードレス電話 etc.)

- General electronic equipment
- Communication equipment (portable telephones, PHS, other wireless applications, etc.)

形名表記法 ORDERING CODE

1	2	3	4	5	6	7	8	9	10	11
定格電圧 (VDC)	シリーズ名	端子電極	形状寸法 (EIA)L×W(mm)	温度特性	公称静電容量 (pF)	容量許容差 (%)	製品厚み (mm)	個別仕様	包装	当社管理記号
A 4 J 6.3 L 10 E 16 T 25 U 50	M 積層コンデンサ	K メッキ品	063(0201) 0.6×0.3 105(0402) 1.0×0.5 107(0603) 1.6×0.8	△B, BJ ±10% △F ±30% △=スペース	例 102 1000 223 22000	K ±10 M ±20 Z $\pm\frac{+80}{-20}$	P 0.3 V 0.5 Z 0.8	- 標準	B 単品(袋詰め) F テーピング(2mmピッチ・178φ) T テーピング(4mmピッチ・178φ)	△ 標準 △=スペース



1	4	6	7	9
Rated voltage(VDC)	Dimensions (case size)(L×W)(mm)	Nominal Capacitance(pF)	Capacitance Tolerance(%)	Special code
A 4 J 6.3 L 10 E 16 T 25 U 50	063(0201) 0.6×0.3 105(0402) 1.0×0.5 107(0603) 1.6×0.8	example 102 1000 223 22000	K ±10 M ±20 Z $\pm\frac{+80}{-20}$	- Standard products
2	5	8	10	11
Series name	Temperature characteristics code	Thickness(mm)	Packaging	Internal code
M Multilayer ceramic capacitors	△B X7R -55~+125°C ±15% BJ X5R -55~+85°C ±15% △F Y5V -30~+85°C $\pm\frac{+22}{-55}$ % △=Blank space	P 0.3 V 0.5 Z 0.8	B Bulk F Tape&Reel(2mm pitch・178φ) T Tape&Reel(4mm pitch・178φ)	△ Standard Products △=Blank space
3	End termination			
K Plated				

外形寸法 EXTERNAL DIMENSIONS

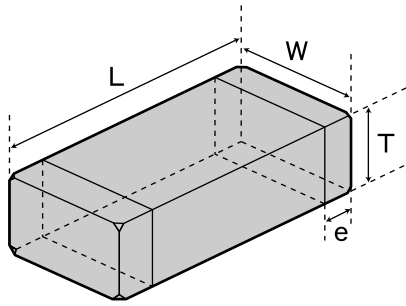

Type(EIA)	L	W	T		e
□MK063 (0201)	0.6±0.03 (0.024±0.001)	0.3±0.03 (0.012±0.001)	0.3±0.03 (0.012±0.001)	P	0.15±0.05 (0.006±0.002)
□MK105 (0402)	1.0±0.05 (0.039±0.002)	0.5±0.05 (0.020±0.002)	0.5±0.05 (0.020±0.002)	V	0.25±0.10 (0.010±0.002)
□MK107 (0603)	1.6±0.10 (0.063±0.004)	0.8±0.10 (0.031±0.004)	0.8±0.10 (0.031±0.004)	Z	0.35±0.25 (0.014±0.010)

Unit : mm(inch)

概略バリエーション AVAILABLE CAPACITANCE RANGE

汎用積層セラミックコンデンサ (General Multilayer Ceramic capacitors)

Type	063						105						107							
Temp.char.	B/X5R			F/Y5V			B/X7R			F/Y5V			B/X7R		F/Y5V					
Cap [pF]	16V	10V	6.3V	6.3V	4V	50V	25V	16V	10V	6.3V	50V	25V	16V	10V	6.3V	50V	25V	50V	25V	
100																				
150																				
220																				
330																				
470																				
680																				
1000																				
1500																				
2200																				
3300																				
4700																				
6800																				
10000																				
15000																				
22000																				
33000																				
47000																				
68000																				
100000																				
220000																				
470000																				
1000000																				

注：グラフの記号は製品厚み記号です。 Note : Letter codes in shaded areas are thickness codes. *1 Items are only available in X5R

温度特性 Temperature Characteristics	温度範囲 Operating temp. range [°C]	基準温度 Ref. Temp. [°C]	静電容量 変化率 Capacitance Change [%]
B	-25~85	20	±10
X7R	-55~125	25	±15
X5R	-55~85	25	±15
F	-25~85	20	+30 -80
Y5V	-30~85	25	+22 -82

記号 Code	許容差 Tolerance	区分 Item
K	±10%	B Char.
M	±20%	B Char.
Z	+80% -20%	F Char.

Type	tan δ ※1	区分 Item
063	≤3.5%	B Char. 16V
	≤5.0%	B Char. 10V
	≤10%	B Char. 0.022~0.1 μF
	≤16%	F Char. 6.3V
	≤20%	F Char. 4V
105	≤2.5%	B Char. 50V, 25V (0.0068 μF)
	≤3.5%	B Char. 16V, 0.027~0.047 μF, 25V (0.01 μF)
	≤5.0%	F Char. 50V, 25V B Char. 0.056~0.22 μF
	≤7.0%	F Char. 0.033 μF, 0.047 μF
	≤9.0%	F Char. 0.068 μF~0.1 μF
	≤10%	B Char. 0.47 μF~1 μF
	≤11%	F Char. 0.22 μF
	≤16%	F Char. 0.47 μF
107	≤20%	F Char. 1 μF
	≤2.5%	B Char.
	≤5.0%	F Char.

※1 測定周波数 Measurement frequency=1±0.1kHz
測定電圧 Measurement voltage =1±0.2Vrms

セレクションガイド
Selection Guide

アイテム一覧
Part Numbers

特性図
Electrical Characteristics

梱包
Packaging

信頼性
Reliability Data

使用上の注意
Precautions



etc

アイテム一覧 PART NUMBERS

063TYPE(0201 case size)

定格電圧 Rated Voltage (DC)	形名 Ordering code	公称 静電容量 Capacitance [pF]	温度特性 Temp.Char	tan δ Dissipation factor [%]Max.	実装条件 Soldering method R:リフロー Reflow soldering W: フロー Wave soldering	静電容量 許容差 Capacitance tolerance [%]	厚み Thickness (mm)(inch)
16V	EMK063 BJ101□P	100	B/X5R	3.5	R	±10% ±20%	0.3±0.03 (0.012±0.001)
	EMK063 BJ151□P	150					
	EMK063 BJ221□P	220					
	EMK063 BJ331□P	330					
	EMK063 BJ471□P	470					
	EMK063 BJ681□P	680					
10V	LMK063 BJ152□P	1500	B/X5R	5	R	±10% ±20%	0.3±0.03 (0.012±0.001)
	LMK063 BJ222□P	2200					
	LMK063 BJ332□P	3300					
	LMK063 BJ472□P	4700					
	LMK063 BJ682□P	6800					
	LMK063 BJ103□P	10000					
6.3V	JMK063 BJ223□P	22000	X5R	10	R	±10% ±20%	0.3±0.03 (0.012±0.001)
	JMK063 BJ473□P	47000					
	JMK063 BJ104□P*	100000					
	JMK063 F223ZP	22000					
4V	JMK063 F473ZP	47000	F/Y5V	16	R	+80% -20%	0.3±0.03 (0.012±0.001)
	AMK063 F104ZP	100000					

形名の□には静電容量許容差記号が入ります。

□Please specify the capacitance tolerance code.

105TYPE(0402 case size)

定格電圧 Rated Voltage (DC)	形名 Ordering code	公称 静電容量 Capacitance [pF]	温度特性 Temp.Char	tan δ Dissipation factor [%]Max.	実装条件 Soldering method R:リフロー Reflow soldering W: フロー Wave soldering	静電容量 許容差 Capacitance tolerance [%]	厚み Thickness (mm)(inch)
50V	UMK105 BJ221□V	220	B/X7R	2.5	R	±10% ±20%	0.5±0.05 (0.020±0.002)
	UMK105 BJ331□V	330					
	UMK105 BJ471□V	470					
	UMK105 BJ681□V	680					
	UMK105 BJ102□V	1000					
	UMK105 BJ152□V	1500					
	UMK105 BJ222□V	2200					
	UMK105 BJ332□V	3300					
25V	TMK105 BJ472□V	4700	B/X7R	3.5	R	±10% ±20%	0.5±0.05 (0.020±0.002)
	TMK105 BJ682□V	6800					
	TMK105 BJ103□V	10000					
16V	TDK105 BJ153□V	15000	B/X7R	3.5	R	±10% ±20%	0.5±0.05 (0.020±0.002)
	TDK105 BJ223□V	22000					
	EMK105 BJ333□V	33000					
	EMK105 BJ473□V	47000					
	EMK105 BJ104□V*	100000					
10V	LMK105 BJ104□V	100000	B/X5R	5	R	±10% ±20%	0.5±0.05 (0.020±0.002)
	LMK105 BJ224□V*	220000					
6.3V	JMK105 BJ224□V	220000	X5R	10	R	±10% ±20%	0.5±0.05 (0.020±0.002)
	JMK105 BJ474□V*	470000					
	JMK105 BJ105□V*	1000000					
50V	UMK105 F103ZV	10000	F/Y5V	5	R	+80% -20%	0.5±0.05 (0.020±0.002)
25V	TMK105 F223ZV	22000					
16V	EMK105 F473ZV	47000					
	EMK105 F104ZV	100000					
10V	LMK105 F224ZV	220000					
6.3V	JMK105 F474ZV	470000					
	JMK105 F105ZV*	1000000					

形名の□には静電容量許容差記号が入ります。

□Please specify the capacitance tolerance code.

* 高温負荷試験の試験電圧は定格電圧の1.5倍

* Test voltage of Loading at high temperature test is 1.5 time of the rated voltage.

高周波積層セラミックコンデンサ

MULTILAYER CERAMIC CAPACITORS

FOR HIGH FREQUENCY APPLICATIONS(1GHz+)

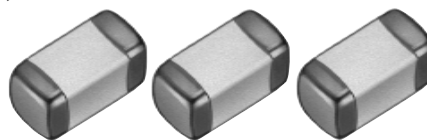

OPERATING TEMP. -55~+125°C

リフロー/REFLOW

特長 FEATURES

- ・積層磁器コンデンサとしては高いQ値が高周波で得られる
- ・1005形状であるため、実装密度の向上、軽量化が図れる
- ・Q values in the high frequency range (1 GHz+) are excellent compared to other types of multilayer capacitors.
- ・The 1005(0402) case size is designed for high density mounting and weight reduction in various applications.

用途 APPLICATIONS

- ・高周波におけるコンデンサのQ値および小型化が求められる用途向き VCO、TCXO etc
- ・高周波回路の特性調整用途
- ・Suitable for those high frequency applications in which a capacitor with both a high Q-value and small size is required such as portable communications and other wireless applications. VCO, TCXO. etc.
- ・Adjustment of characteristics in high frequency circuit

形名表記法 ORDERING CODE

1	4	6	8	10
定格電圧 (VDC)	形状寸法(EIA)L×W(mm)	公称静電容量 [pF]	製品厚み(mm)	包装
E 16 U 50	105(0402) 1.0×0.5	例 020 2 4R3 4.3 ※R=小数点	W 0.5	B 単品(袋づめ) F リールテーピング品(178μmピッチ)
2	5	7	9	
シリーズ名	温度特性(ppm/°C)	容量許容差	個別仕様	
V 高周波用積層コンデンサ	CH 0±60 RH -220±60	B ±0.1pF J ±5%	- 標準	
3				
端子電極				
K メッキ品				

U V K 1 0 5 R H 4 R 3 J W - F

1 2 3 4 5 6 7 8 9 10

1	4	6	8	10
Rated voltage(VDC)	Dimensions (case size)(L×W)(mm)	Nominal Capacitance(pF)	Thickness(mm)	Packaging
E 16 U 50	105(0402) 1.0×0.5	example 020 2 4R3 4.3 ※R=Decimal point	W 0.5	B Bulk F Tape&Reel(2mm pitch・178μ)
2	5	7	9	
Series name	Temperature characteristics(ppm/°C)	Capacitance Tolerances	Special code	
V MULTILAYER CERAMIC CAPACITORS FOR HIGH FREQUENCY	CH 0±60 RH -220±60	B ±0.1pF J ±5%	- Standard Products	
3				
End termination				
K Plated				

外形寸法 EXTERNAL DIMENSIONS

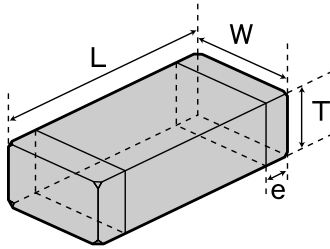

Type(EIA)	L	W	T	e
□VK105 (0402)	1.0±0.05 (0.039±0.002)	0.5±0.05 (0.020±0.002)	0.5±0.05 (0.020±0.002)	0.25±0.1 (0.010±0.004)

Unit : mm(inch)

アイテム一覧 PART NUMBERS

定格電圧 Rated Voltage (DC)	形名 Ordering code	温度特性 Temperature characteristics		公称静電容量 Capacitance [pF]	静電容量許容差 Capacitance tolerance	Q規格値 (at 1GHz) Q (min)	厚み Thickness [mm]	Q typ. 値 (参考値) Typical Q
		CH	RH					
E: 16V U: 50V	□VK105 CH0R3BW	●		0.3	±0.1pF	300	0.5±0.05	1200
	□VK105 CH0R4BW	●		0.4		300		1200
	□VK105 CH0R5BW	●		0.5		300		1200
	□VK105 CH0R6BW	●		0.6		300		1100
	□VK105 CH0R7BW	●		0.7		300		1100
	□VK105 CH0R8BW	●		0.8		300		1000
	□VK105 CH0R9BW	●		0.9		300		950
	□VK105 CH010BW	●		1.0		300		950
	□VK105 CH1R1BW	●		1.1		280		930
	□VK105 CH1R2BW	●		1.2		270		850
	□VK105 CH1R3BW	●		1.3		260		740
	□VK105 CH1R5BW	●		1.5		240		710
	□VK105 CH1R6BW	●		1.6		230		670
	□VK105 CH1R8BW	●		1.8		210		650
	□VK105 CH020BW	●		2.0		190		610
	□VK105 CH2R2JW	●		2.2		180		530
	□VK105 CH2R4JW	●		2.4		170		510
	□VK105 CH2R7JW	●		2.7		150		460
	□VK105 CH030JW	●		3.0		130		390
	□VK105 CH3R3JW	●		3.3		120		370
	□VK105 CH3R6JW	●		3.6	110	360		
	□VK105 CH3R9JW	●		3.9	99	360		
	□VK105 CH4R3JW	●		4.3	84	360		
	□VK105 CH4R7JW	●		4.7	84	340		
	□VK105 CH5R1JW	●		5.1	84	320		
	□VK105 RH0R5BW		●	0.5	300	1100		
	□VK105 RH0R6BW		●	0.6	300	1000		
	□VK105 RH0R7BW		●	0.7	300	1000		
	□VK105 RH0R8BW		●	0.8	300	970		
	□VK105 RH0R9BW		●	0.9	300	950		
	□VK105 RH010BW		●	1.0	300	900		
	□VK105 RH1R1BW		●	1.1	280	900		
	□VK105 RH1R2BW		●	1.2	270	740		
	□VK105 RH1R3BW		●	1.3	260	700		
	□VK105 RH1R5BW		●	1.5	240	680		
	□VK105 RH1R6BW		●	1.6	230	640		
	□VK105 RH1R8BW		●	1.8	210	620		
	□VK105 RH020BW		●	2.0	190	570		
	□VK105 RH2R2JW		●	2.2	180	480		
	□VK105 RH2R4JW		●	2.4	170	470		
□VK105 RH2R7JW		●	2.7	150	420			
□VK105 RH030JW		●	3.0	130	360			
□VK105 RH3R3JW		●	3.3	120	350			
□VK105 RH3R6JW		●	3.6	110	340			
□VK105 RH3R9JW		●	3.9	99	340			
□VK105 RH4R3JW		●	4.3	84	340			
□VK105 RH4R7JW		●	4.7	84	320			
□VK105 RH5R1JW		●	5.1	84	310			

注：□には定格電圧記号がはいるます。 □Please specify the Rated Voltage code.

仕様 SPECIFICATIONS

温度特性 Temperature Characteristics	使用温度範囲 Operating Temperature range	温度係数範囲 Temperature Coefficient range [ppm/°C]	静電容量許容差 Capacitance Tolerance (区分)
CH	-55~+125°C	0±60	±0.1pF(~2.0pF)
RH		-220±60	±5% (2.2pF~)

■容量値とQの関係例(CH特性例) Capacitance vs Q value (Typical for CH T.C.)

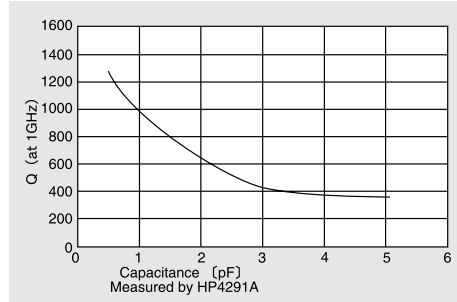

セレクションガイド
Selection Guide

アイテム一覧
Part Numbers

特性図
Electrical Characteristics

梱包
Packaging

信頼性
Reliability Data

使用上の注意
Precautions



etc

超低歪積層セラミックコンデンサ (CFCAP®)

SUPER LOW DISTORTION MULTILAYER CERAMIC CAPACITORS (CFCAP®)

OPERATING TEMP. -55~+125°C



リフロー/REFLOW

特長 FEATURES

- ・新規開発を行った誘電体材料を使用し優れた温度特性と内部電極にNiを用いることで、小型・高容量・低コストを実現しました
- ・低歪み率、低ショックノイズでアナログ回路や携帯機器のデジタル回路に最適です
- ・耐熱性、耐破壊電圧、機械的強度が高くフィルムコンデンサの置き換えに最適です

- ・ Newly developed dielectric material and the use of nickel for internal electrodes provide excellent temperature characteristics with high capacitance, small case size and low cost.
- ・ Low distortion and low shock noise make these capacitors well suited for use in analog or digital mobile devices.
- ・ Excellent heat-resistance, high break down voltage, and mechanical strength make these capacitors well suited for replacing film capacitors.

用途 APPLICATIONS

- ・ AV関連機器などの信号回路
- ・ アナログ信号のカップリング用途
- ・ 携帯電話のPLL回路
- ・ 良好な温度特性による時定数回路、発信回路、フィルタなど

- ・ Signal line for AV products
- ・ Analog signal coupling applications
- ・ PLL circuit of mobile phones
- ・ Good temperature characteristics for time constant circuits, oscillation circuits and filters

形名表記法 ORDERING CODE

1 定格電圧 (VDC)	3 端子電極	5 シリーズ記号	7 容量許容差	9 個別仕様
U 50 G 35 T 25 E 16 L 10	K メッキ品	SD スタンダード	K ±10 %	- 標準
2 シリーズ名	4 形状寸法 (EIA)L×W(mm)	6 公称静電容量 (pF)	8 製品厚み (mm)	10 包装
M 積層コンデンサ	107(0603) 1.6×0.8 212(0805) 2.0×1.25 316(1206) 3.2×1.6	例 223 22,000 104 100,000	A 0.8 D 0.85 F 1.15 G 1.25 L 1.6	B 単品 (袋づめ) T リールテーピング
				11 当社管理記号
				○ 標準品 ○=スペース



1 Rated voltage(VDC)	3 End termination	5 Series Symbol	7 Capacitance tolerances(%)	9 Special code
U 50 G 35 T 25 E 16 L 10	K Plated	SD Standard	K ±10	- Standard products
2 Multilayer ceramic capacitors	4 Dimensions(case size)(mm)	6 Nominal capacitance(pF)	8 Thickness(mm)	10 Packaging
M	107(0603) 1.6×0.8 212(0805) 2.0×1.25 316(1206) 3.2×1.6	example 223 22,000 104 100,000	A 0.8 D 0.85 F 1.15 G 1.25 L 1.6	B Bulk T Tape & reel
				11 Internal code
				○ Standard products ○=Blank space

外形寸法 EXTERNAL DIMENSIONS

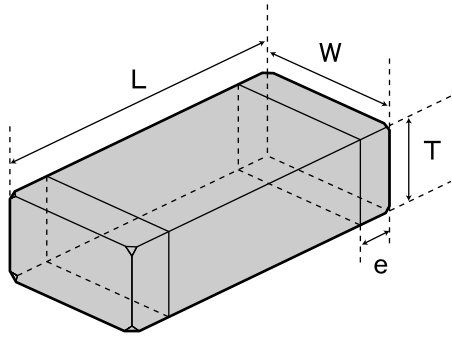

Type(EIA)	L	W	T		e
TMK107 (0603)	1.6±0.10 (0.063±0.004)	0.8±0.10 (0.031±0.004)	0.8±0.10 (0.031±0.004)	A	0.35±0.25 (0.014±0.010)
TMK212 (0805)	2.0±0.10 (0.079±0.004)	1.25±0.10 (0.049±0.004)	0.85±0.10 (0.033±0.004)	D	0.5±0.25 (0.020±0.010)
			1.25±0.10 (0.049±0.004)	G	
TMK316 (1206)	3.2±0.15 (0.126±0.006)	1.6±0.15 (0.063±0.006)	1.15±0.10 (0.045±0.004)	F	0.5 ^{+0.35} _{-0.25} (0.020 ^{+0.014} _{-0.010})
			1.6±0.20 (0.063±0.008)	L	

Unit : mm (inch)

概略バリエーション AVAILABLE CAPACITANCE RANGE

Cap [nF]	Type	107				212				316	
	Temp.Char	SD				SD				SD	
	VDC [pF:3digits]	50V	25V	16V	10V	50V	35V	16V	10V	35V	25V
1	102	A									
1.5	152	A									
2.2	222	A									
3.3	332	A									
4.7	472		A			D					
6.8	682			A		D					
10	103			A		D					
15	153				A		D				
22	223				A		G				
33	333							D		F	
47	473								D		F
68	683								G		F
100	104								G		L

※グラフ記号は製品厚みを表します。 Letters inside the shaded boxes indicate thickness.

シリーズコード Series Code	静電容量許容差(%) Capacitance tolerance	tanδ[%] Dissipation factor
SD	±10(K)	0.1%max.

セレクションガイド
Selection Guide



アイテム一覧
Part Numbers



特性図
Electrical Characteristics



梱包
Packaging



信頼性
Reliability Data



使用上の注意
Precautions



アイテム一覧 PART NUMBERS

■107TYPE (0603 case size)

定格電圧 Rated Voltage	形名 Ordering code	公称静電容量 Capacitance [nF]	温度特性 Temperature characteristics Standard type	tan δ Dissipation factor [%]Max.	実装条件 Soldering method R:リフロー Reflow soldering W:フロー Wave soldering	静電容量許容差 Capacitance tolerance	厚み Thickness [mm](inch)
50V	UMK107 SD102KA	1.0	Standard type	0.1	R	±10%*	0.8±0.1 (0.031±0.004)
	UMK107 SD122KA	1.2					
	UMK107 SD152KA	1.5					
	UMK107 SD182KA	1.8					
	UMK107 SD222KA	2.2					
	UMK107 SD272KA	2.7					
	UMK107 SD332KA	3.3					
25V	TMK107 SD392KA	3.9					
	TMK107 SD472KA	4.7					
	EMK107 SD562KA	5.6					
16V	EMK107 SD682KA	6.8					
	EMK107 SD822KA	8.2					
	EMK107 SD103KA	10					
	EMK107 SD123KA	12					
10V	LMK107 SD153KA	15					
	LMK107 SD183KA	18					
	LMK107 SD223KA	22					

*: J公差(±5%)も対応致します。御相談ください。

■212TYPE (0805 case size)

定格電圧 Rated Voltage	形名 Ordering code	公称静電容量 Capacitance [nF]	温度特性 Temperature characteristics Standard type	tan δ Dissipation factor [%]Max.	実装条件 Soldering method R:リフロー Reflow soldering W:フロー Wave soldering	静電容量許容差 Capacitance tolerance	厚み Thickness [mm](inch)
50V	UMK212 SD392KD	3.9	Standard type	0.1	R	±10%*	0.85±0.1 (0.033±0.004)
	UMK212 SD472KD	4.7					
	UMK212 SD562KD	5.6					
	UMK212 SD682KD	6.8					
	UMK212 SD822KD	8.2					
	UMK212 SD103KD	10					
35V	GMK212 SD123KD	12					
	GMK212 SD153KD	15					
	GMK212 SD183KG	18					
	GMK212 SD223KG	22					
	GMK212 SD273KG	27					
16V	EMK212 SD333KD	33					
10V	LMK212 SD473KD	47					
	LMK212 SD683KG	68					
	LMK212 SD104KG	100					

*: J公差(±5%)も対応致します。御相談ください。

■316TYPE (1206 case size)

定格電圧 Rated Voltage	形名 Ordering code	公称静電容量 Capacitance [nF]	温度特性 Temperature characteristics Standard type	tan δ Dissipation factor [%]Max.	実装条件 Soldering method R:リフロー Reflow soldering W:フロー Wave soldering	静電容量許容差 Capacitance tolerance	厚み Thickness [mm](inch)
35V	GMK316 SD333KF	33	Standard type	0.1	R	±10%*	1.15±0.1 (0.045±0.004)
	GMK316 SD393KF	39					
25V	TMK316 SD473KF	47					
	TMK316 SD563KF	56					
	TMK316 SD683KF	68					
	TMK316 SD823KL	82					
	TMK316 SD104KL	100					

*: J公差(±5%)も対応致します。御相談ください。

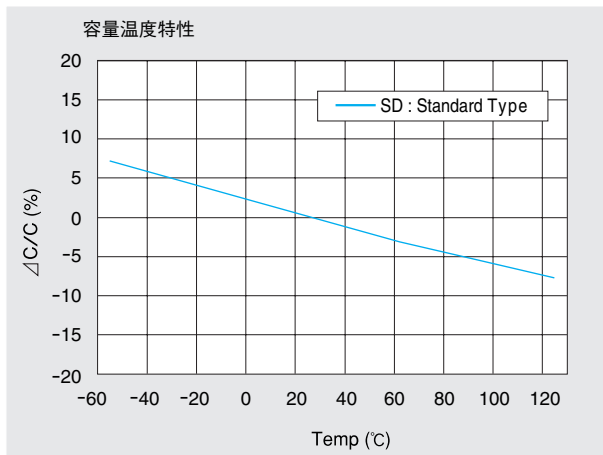

Super Low Distortion Multilayer Ceramic Capacitors (CFCAP)

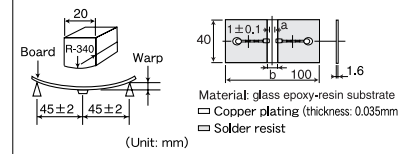
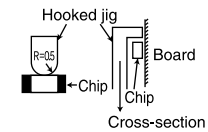
Item	Specified Value	Test Methods and Remarks
1. Operating Temperature Range	-55 to +125°C	
2. Storage Temperature Range	-55 to +125°C	
3. Rated Voltage	10VDC, 16VDC, 25VDC, 35VDC, 50VDC,	
4. Withstanding Voltage Between terminals	No breakdown or damage	Applied voltage: Rated voltage×3 Duration: 1 to 5 sec. Charge/discharge current: 50mA max.
5. Insulation Resistance	10000 MΩ or 500MΩ μF, whichever is smaller	Applied voltage: Rated voltage Duration: 60±5 sec. Charge/discharge current: 50mA max.
6. Capacitance (Tolerance)	±10%	Measuring frequency : 1 k Hz±10% Measuring voltage : 1±0.2Vrms Bias application: None
7. Tangent of Loss Angle (tan δ)	0.1%max	Measuring frequency : 1 k Hz±10% Measuring voltage : 1±0.2Vrms Bias application: None
8. Resistance to Flexure of Substrate	Appearance: No abnormality Capacitance change: ±5%	Warp: 1mm Speed: 0.5mm/second Duration: 10 seconds The measurement shall be made with the board in the bent position.  (Unit: mm)
9. Body strength		
10. Adhesion of electrode	No separation or indication of separation of electrode.	Applied force: 5N Duration: 30 ±5 seconds 
11. Solderability	At least 95% of terminal electrode is covered by new solder.	Solder temp.: 230 ±5°C Duration: 4 ±1 seconds
12. Resistance to soldering	Appearance: No abnormality Capacitance change: ±2.5% max. tanδ: Initial value Insulation resistance: Initial value Withstanding voltage (between terminals): No abnormality	Solder temp.: 270 ±5°C Duration: 3 ±0.5 seconds Preheating conditions: 80 to 100°C, 2 to 5 min. or 5 to 10 min. 150 to 200°C, 2 to 5 min. or 5 to 10 min. Recovery: Recovery for the following period under the standard condition after the test: 24 ±2hrs
13. Thermal shock	Appearance: No abnormality Capacitance change: ±2.5% max tanδ: Initial value Insulation resistance: Initial value Withstanding voltage (between terminals): No abnormality	Conditions for 1 cycle: Step 1: Minimum operating temperature +0/-3 °C 30±3 minutes Step 2: Room temperature 2 to 3min. Step 3: Maximum operating temperature -0/+3 °C 30±3 minutes Step 4: Room temperature 2 to 3min. Number of cycles: 5 times Recovery after the test: 24±2hrs
14. Damp heat (steady state)	Appearance: No abnormality Capacitance change: ±5% max tanδ: 0.5% max Insulation resistance 50MΩ μF or 1000MΩ whichever is smaller	Temperature: 40±2°C Humidity: 90 to 95% RH Duration: 500 +24/-0 hrs Recovery: Recovery for the following period under the standard condition after the removal from test chamber: 24 ±2hrs

Super Low Distortion Multilayer Ceramic Capacitors (CFCAP)

Item	Specified Value	Test Methods and Remarks
15.Loading under Damp Heat	Appearance: No abnormality Capacitance change: $\pm 7.5\%$ max $\tan\delta$: 0.5% max Insulation resistance: $25M\Omega\mu F$ or $500M\Omega$ whichever is smaller	According to JIS C 5102 clause 9.9. Temperature: $40\pm 2^{\circ}C$ Humidity:90 to 95% RH Duration: 500_{-0}^{+24} hrs Applied voltage: Rated voltage Charge/discharge current:50mA max Recovery: Recovery for the following period under the standard condition after the removal from test chamber: 24 ± 2 hrs
16.Loading at High Temperature	Appearance: No abnormality Capacitance change: $\pm 3\%$ max $\tan\delta$: 0.35% max Insulation resistance: $50M\Omega\mu F$ or $1000M\Omega$ whichever is smaller	According to JIS C 5102 clause 9.9. Temperature: $125\pm 3^{\circ}C$ Duration: 1000_{-0}^{+48} hrs Applied voltage: Rated voltage x 2 Recovery: Recovery for the following period under the standard condition after the removal from test chamber: 24 ± 2 hrs

Note on standard condition: "standard condition" referred to herein is defined as follows.

Temperature: 5 to 35°C, Relative humidity: 45 to 85 %, Air pressure: 86 to 106kpa,

When there are questions concerning measurement results: In order to provide correlation data, the test shall be conducted under condition.

Temperature: $20\pm 2^{\circ}C$, Relative humidity: 65 to 70 %, Air pressure: 86 to 106kpa

Unless otherwise specified,all the tests are conducted under the "standard condition."

中高耐圧積層セラミックコンデンサ

MEDIUM-HIGH VOLTAGE MULTILAYER CERAMIC CAPACITOR

	code	Temp.characteristics	operating Temp. range
OPERATING TEMP.	BJ	B	- 25~+85°C
		X5R	- 55~+85°C
		X7R	- 55~+125°C

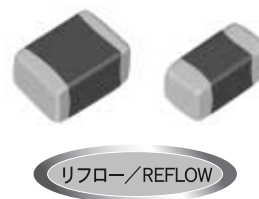

特長 FEATURES

- ・内部電極にNi金属を使用しており、マイグレーションが発生せず、高信頼性を示す。
- ・高定格電圧でありながら小型形状
- ・The use of Nickel(Ni) as material for internal electrodes almost completely eliminates migration and high reliability
- ・Small case sizes with high rated voltage

用途 APPLICATIONS

- ・一般電話交換機
- ・インバータ
- ・無線、通信基地局
- ・General telephone exchange
- ・Inverter.
- ・Wireless and Telecommunication base.

形名表記法 ORDERING CODE

1 定格電圧 (VDC)	3 端子電極	5 温度特性 (%)	7 容量許容差	9 個別仕様
H 100 Q 250 S 630	K メッキ品	B J ±10	K ±10% M ±20%	- 標準
2 シリーズ名	4 形状寸法 (EIA)L×W(mm)	6 公称静電容量 (pF)	8 製品厚み (mm)	10 包装
M 積層コンデンサ	212(0805) 2.0×1.25 316(1206) 3.2×1.6 325(1210) 3.2×2.5 432(1812) 4.5×3.2	例 104 100,000 105 1,000,000	G 1.25 F 1.15 L 1.6 N 1.9 M 2.5	B 単品(袋詰め) T リールテーピング
				11 当社管理記号
				△ 標準品 △=スペース

H	M	K	3	1	6	B	J	1	0	4	K	L	-	T	○
1	2	3	4	5	6	7	8	9	10	11					

1 Rated voltage(VDC)	3 End termination	5 Temperature characteristics code	7 Capacitance tolerances(%)	9 Special code
H 100 Q 250 S 630	K Plated	B J X7R -55~+125°C±15% B J X5R -55~+85°C±15%	K ±10 M ±20	- Standard products
2 Series name	4 Dimensions(case size)(mm)	6 Nominal capacitance(pF)	8 Thickness(mm)	10 Packaging
M Multilayer ceramic capacitors	212(0805) 2.0×1.25 316(1206) 3.2×1.6 325(1210) 3.2×2.5 432(1812) 4.5×3.2	example 104 100,000 105 1,000,000	G 1.25 F 1.15 L 1.6 N 1.9 M 2.5	B Bulk T Tape & reel
				11 Internal code
				△ Standard products △=Blank space

外形寸法 EXTERNAL DIMENSIONS

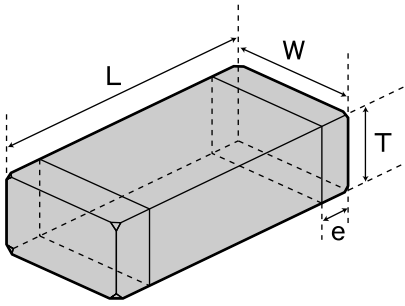

Type (EIA)	L	W	T		e
□MK212 (0805)	2.0±0.10 (0.079±0.004)	1.25±0.10 (0.049±0.004)	1.25±0.10 (0.049±0.004)	G	0.3以上 (0.012min.)
□MK316 (1206)	3.2±0.15 (0.126±0.006)	1.6±0.15 (0.063±0.006)	1.15±0.10 (0.045±0.004)	F	0.3以上 (0.012min.)
			1.6±0.20 (0.063±0.008)	L	
□MK325 (1210)	3.2±0.3 (0.126±0.012)	2.5±0.20 (0.098±0.008)	1.15±0.10 (0.045±0.004)	F	0.3以上 (0.012min.)
			1.9±0.20 (0.075±0.008)	N	
□MK432 (1812)	4.5±0.4 (0.177±0.016)	3.2±0.30 (0.126±0.012)	2.5±0.20 (0.098±0.008)	M	0.3以上 (0.012min.)

Unit : mm(inch)

概略バリエーション AVAILABLE CAPACITANCE RANGE

Cap [μF]	Type	212			316					325					432						
	Temp. Char VDC	BJ/X7R 100V	BJ/X7R 250V	BJ/X5R 250V	BJ/X7R 100V	BJ/X7R 250V	BJ/X5R 250V	BJ/X7R 630V	BJ/X5R 630V	BJ/X7R 100V	BJ/X7R 250V	BJ/X5R 250V	BJ/X7R 630V	BJ/X5R 630V	BJ/X7R 100V	BJ/X5R 100V	BJ/X7R 250V	BJ/X5R 250V	BJ/X7R 630V	BJ/X5R 630V	
	[pF:3digits]																				
0.01	103	G	G					F													
0.022	223	G		G					L				N								
0.047	473	G			L	L							N								M
0.1	104	G			L		L			F	N									M	M
0.22	224				L					N		N						M			
0.47	474									N					M				M		
1.0	105									N					M						
2.2	225															M					

※グラフ記号は製品厚みを表します。 Letters inside the shaded boxes indicate thickness.

温度特性コード Temp. char.Code	温度特性 Temperature characteristics				静電容量許容差[%] Capacitance tolerance	tanδ[%] Dissipation factor	
	準拠規格 Applicable standard		温度範囲[°C] Temperature range	基準温度[°C] Ref. Temp.			静電容量変化率[%] Capacitance change
	JIS	B					
BJ		X7R	-55~125	25	±15	±20(M) ±10(K)	3.5%(100V) 2.5%(250V, 630V)
		X5R	-55~85	25	±15		

セレクションガイド
Selection Guide



etc

アイテム一覧
Part Numbers



特性図
Electrical Characteristics



梱包
Packaging



信頼性
Reliability Data



使用上の注意
Precautions



アイテム一覧 PART NUMBERS

■212TYPE(0805 case size)

定格電圧 RatedVoltage	形名 Ordering code	公称静電容量 Capacitance [μF]	温度特性 Temperature characteristics	tan δ Dissipation factor [%]Max.	実装条件 Soldering method R:リフロー Rework soldering W:フロウ Wave soldering	静電容量許容差 Capacitance tolerance	厚み Thickness [mm] (inch)
100V	HMK212 BJ103□G	0.01	BJ/X7R	3.5	R	±10%, ±20%	1.25±0.1 (0.049±0.004)
	HMK212 BJ223□G	0.022					
	HMK212 BJ473□G	0.047					
	HMK212 BJ104□G	0.1					
250V	QMK212 BJ103□G	0.01	BJ/X5R	2.5			
	QMK212 BJ223□G	0.022					

■316TYPE(1206 case size)

定格電圧 RatedVoltage	形名 Ordering code	公称静電容量 Capacitance [μF]	温度特性 Temperature characteristics	tan δ Dissipation factor [%]Max.	実装条件 Soldering method R:リフロー Rework soldering W:フロウ Wave soldering	静電容量許容差 Capacitance tolerance	厚み Thickness [mm] (inch)
100V	HMK316 BJ473□L	0.047	BJ/X7R	3.5	R	±10%, ±20%	1.6±0.2 (0.063±0.008)
	HMK316 BJ104□L	0.1					
	HMK316 BJ224□L	0.22					
250V	QMK316 BJ473□L	0.047	BJ/X5R	2.5			1.15±0.1 (0.045±0.004)
	QMK316 BJ104□L	0.1					
630V	SMK316 BJ103□F	0.01	BJ/X7R	2.5			1.6±0.2 (0.063±0.008)
	SMK316 BJ223□L	0.022	BJ/X5R				1.6±0.2 (0.063±0.008)

■325TYPE(1210 case size)

定格電圧 RatedVoltage	形名 Ordering code	公称静電容量 Capacitance [μF]	温度特性 Temperature characteristics	tan δ Dissipation factor [%]Max.	実装条件 Soldering method R:リフロー Rework soldering W:フロウ Wave soldering	静電容量許容差 Capacitance tolerance	厚み Thickness [mm] (inch)
100V	HMK325 BJ104□F	0.10	BJ/X7R	3.5	R	±10%, ±20%	1.15±0.1 (0.045±0.004)
	HMK325 BJ224□N	0.22					
	HMK325 BJ474□N	0.47					
	HMK325 BJ105□N	0.1					
250V	QMK325 BJ473□N	0.047	BJ/X5R	2.5			1.9±0.2 (0.075±0.008)
	QMK325 BJ104□N	0.10					
	QMK325 BJ224□N	0.22					
630V	SMK325 BJ223□N	0.022	BJ/X7R	2.5			
	SMK325 BJ473□N	0.047	BJ/X5R				

■432TYPE(1812 case size)

定格電圧 RatedVoltage	形名 Ordering code	公称静電容量 Capacitance [μF]	温度特性 Temperature characteristics	tan δ Dissipation factor [%]Max.	実装条件 Soldering method R:リフロー Rework soldering W:フロウ Wave soldering	静電容量許容差 Capacitance tolerance	厚み Thickness [mm] (inch)
100V	HMK432 BJ474□M	0.47	BJ/X7R	3.5	R	±10%, ±20%	2.5±0.2 (0.098±0.008)
	HMK432 BJ105□M	1.0					
	HMK432 BJ225□M	2.2					
250V	QMK432 BJ104□M	0.1	BJ/X7R	2.5			
	QMK432 BJ224□M	0.22					
	QMK432 BJ474□M	0.47					
630V	SMK432 BJ473□M	0.047	BJ/X7R	2.5			
	SMK432 BJ104□M	0.1	BJ/X5R				

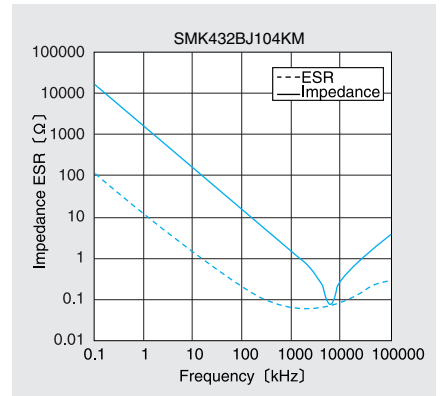
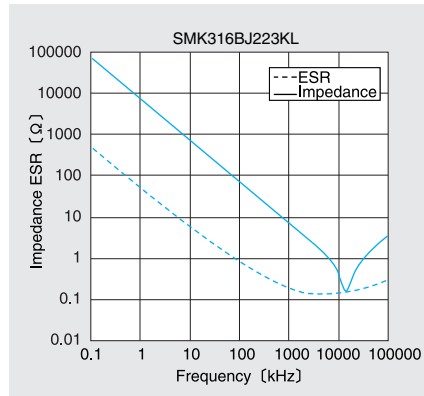
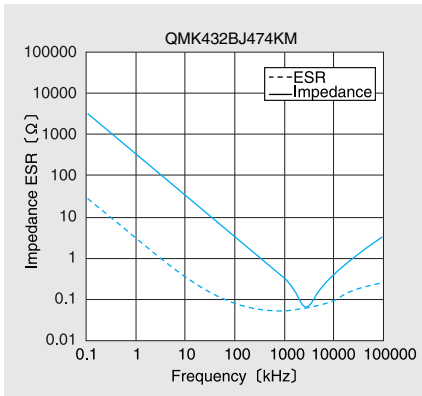
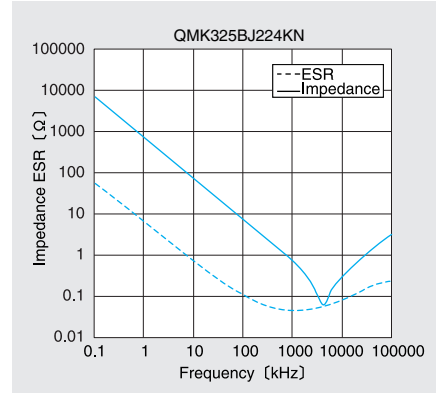
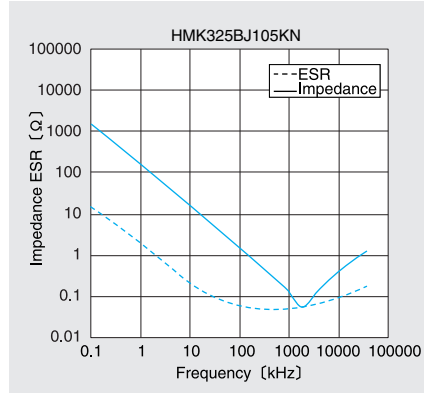
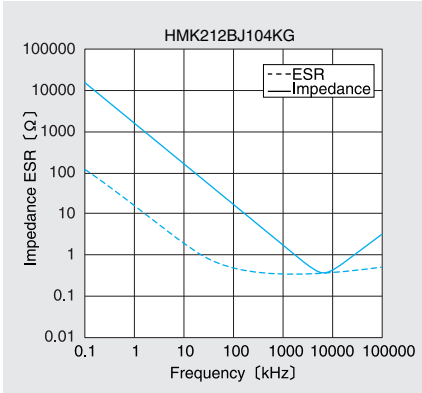

静電容量—温度特性 Temperature characteristics

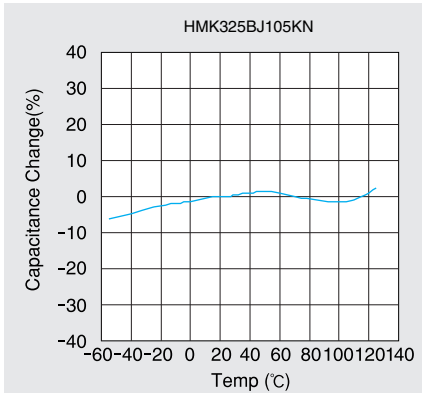

MEDIUM-HIGH VOLTAGE MULTILAYER CERAMIC CAPACITOR

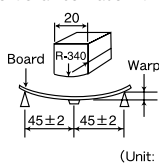
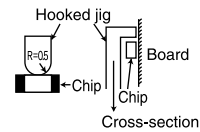
Item	Specified Value	Test Methods and Remarks
1.Operating Temperature Range	X7R : -55 to +125°C X5R: -55 to +85°C B J : -25 to +85°C	
2.Storage Temperature Range	X7R : -55 to +125°C X5R: -55 to +85°C B J : -25 to +85°C	
3.Rated Voltage	100VDC, 250VDC, 630VDC	
4.Withstanding Voltage Between terminals	No breakdown or damage	Applied voltage:Rated voltage×2.5(100V) Rated voltage×2(250V) Rated voltage×1.2(630V) Duration : 1~5sec. Charge/discharge current : 50mAmax.
5.Insulation Resistance	100MΩ μ F or 10GΩ , whichever is smaller.	Applied voltage:Rated voltage(100V, 250V) 500V(630V) Duration : 60± 5 sec. Charge/discharge current : 50mAmax.
6.Capacitance(Tolerance)	±20%、±10%	Measuring frequency:1kHz±10% Measuring voltage:1±0.2Vrms Bias application:None
7.Tangent of Loss Angel	3.5%max(100V). 2.5%max(250V, 630V).	Measuring frequency:1kHz±10% Measuring voltage:1±0.2Vrms Bias application:None
8.Temperature Characteristic of Capacitance	B J : ±10% (-25 to +85°C) X7R: ±15% (-55 to +125°C) X5R: ±15% (-55 to +85°C)	According to JIS 5102 clause7.12. Charge of maximum capacitance deviation in step 1 to 5 Temperature at step 1:+25°C Temperature at step 2:minimum operating temperature Temperature at step 3:+25°C(Reference temperature) Temperature at step 4:maximum operating temperature Temperature at step 5:+25°C Reference temperature Characteristic B shall be +20°C
9.Resistance to Flexure of Substrate	Appearance:No abnormality Capacitance change:Within±10%	Warp:1mm Testing boade:glass epoxy-resin substrate Thickness:1.6mm The measurement shall be made with board in the bent position  (Unit: mm)
10.Adhesion of Electrode	No separation or indication of separation of electrode	Applied force:5N Duration:30±5sec.  Cross-section
11.Solderability	At least 75% of terminal electrode is covered by solder	Solder temperature:230±5°C Duration:4±1sec.
12.Resistance to Soldering	Appearance:No abnormality Capacitance change:Within±10%(×5R, B J), ±15%(×7R) tan δ : Initial value Insulation resistance:Initial value Withstanding voltage(between terminals): No abnormality	Preconditioning:Thermal treatment(at 150°C for 1hr) Solder temperature:270±5°C Duration:3±0.5sec. Preheating conditions: 80 to 100°C, 2 to 5 min. 150 to 200°C, 2 to 5 min. Recovery:Recovery for the following period under the stander condition after the test. 48±4hrs
13.Thermal shock	Appearance:No abnormality Capacitance change:Within±15%(100V), ±7.5%(250V, 630V) tan δ : Initial value Insulation resistance:Initial value	Preconditioning:Thermal treatment(at 150°C for 1hr) Conditions for 1 cycle Step 1:Minimum operating temperature +0/-3°C 30±3min. Step 2:Room temperature 2 to 3min. Step 3:Maximum operating temperature +0/-3°C 30±3min. Step4:Room temperature 2 to 3min. Number of cycles:5 times Recovery after the test:48±4hrs

アレイ形積層セラミックコンデンサ

ARRAY TYPE MULTILAYER CERAMIC CAPACITOR

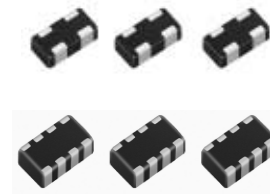

リフロー／REFLOW

	code	Temp.characteristics	operating Temp. range
OPERATING TEMP.	BJ	B	-25~+85°C
		X5R	-55~+85°C
		X7R	-55~+125°C
	CH	C0H	-55~+125°C

特長 FEATURES

- 2125形状で4回路構成であるため、より高密度、高効率な実装を実現
- 1回路あたりの容量は1 μ Fの大容量
- 内部電極には、信頼性とコストパフォーマンスに優れたNiを使用しています。
- 4 circuits in 2125 package allows higher placement density and efficiency
- The capacitance in each circuit, F or B dielectric, is 1 μ F
- Internal electrode is nickel for increased cost performance and reliability

用途 APPLICATIONS

- 一般電子機器用
- 通信機器用(携帯電話、PHS、コードレス電話etc)
- General electronic equipment
- Communication equipment (mobile phone, PHS, cordless phone, etc.)

形名表記法 ORDERING CODE

1	3	5	7	9
定格電圧 (VDC)	端子電極	温度特性	容量許容差	個別仕様
J 6.3 L 10 E 16 T 25 U 50	K メッキ品	BJ ± 10 [%] CH 0 ± 60 [ppm/°C]	M ± 20 % K ± 10 % F ± 1 pF	- 標準
2	4	6	8	10
シリーズ名	形状寸法 (EIA) L×W(mm)	公称静電容量 (pF)	製品厚み (mm)	包装
4 4 連積層コンデンサ 2 2 連積層コンデンサ	110(0504) 1.4×1.0 212(0805) 2.0×1.25 316(1206) 3.2×1.6	例 104 100,000 105 1,000,000	B 0.6 A 0.8 D 0.85 F 1.15	T リールテーピング
		6		11
		Nominal capacitance (pF)		当社管理記号
		example 104 100,000 105 1,000,000		Δ 標準品 Δ = スペース

E	4	K	2	1	2	B	J	1	0	4	M	D	-	T	○
1	2	3	4	5	6	7	8	9	10	11					

1	3	5	7	9
Rated voltage (VDC)	End termination	Temperature characteristics code	Capacitance tolerances (%)	Special code
J 6.3 L 10 E 16 T 25 U 50	K Plated	BJ X5R -55~+85°C ± 15 % X7R -55~+125°C ± 15 % CH C0H 0 ± 60 [ppm/°C]	M ± 20 K ± 10 F ± 1 pF	- Standard products
2	4	6	8	10
Series name	Dimensions (case size) (mm)	Nominal capacitance (pF)	Thickness (mm)	Packaging
4 4 circuit multilayer capacitors 2 2 circuit multilayer capacitors	110(0504) 1.4×1.0 212(0805) 2.0×1.25 316(1206) 3.2×1.6	example 104 100,000 105 1,000,000	B 0.6 A 0.8 D 0.85 F 1.15	T Tape & reel
				11
				Internal code
				Δ Standard products Δ = Blank space

外形寸法 EXTERNAL DIMENSIONS

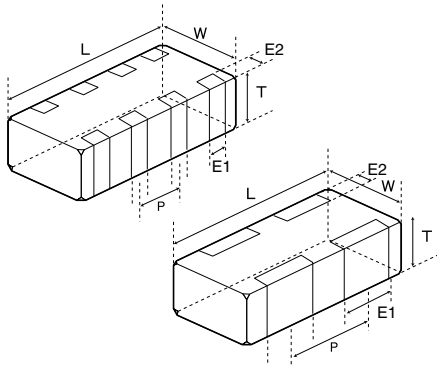

Type(EIA)	L	W	E1	E2	P	T	
□2K110 (0504)	1.37±0.07 (0.054±0.003)	1.00±0.08 (0.039±0.003)	0.36±0.10 (0.014±0.004)	0.20±0.10 (0.008±0.004)	0.64±0.10 (0.025±0.004)	B	0.60±0.06 (0.024±0.003)
						A	0.80±0.08 (0.031±0.003)
□4K212 (0805)	2.00±0.10 (0.079±0.004)	1.25±0.10 (0.049±0.004)	0.25±0.10 (0.010±0.004)	0.25±0.15 (0.010±0.006)	0.50±0.10 (0.020±0.004)	D	0.85±0.10 (0.033±0.004)
□2K212 (0805)	2.00±0.10 (0.079±0.004)	1.25±0.10 (0.049±0.004)	0.50±0.20 (0.020±0.008)	0.25±0.15 (0.010±0.006)	1.00±0.10 (0.039±0.004)	D	0.85±0.10 (0.033±0.004)
□4K316 (1206)	3.20±0.15 (0.126±0.006)	1.60±0.15 (0.063±0.006)	0.40±0.20 (0.016±0.008)	0.30±0.20 (0.012±0.008)	0.80±0.10 (0.031±0.004)	F	1.15±0.15 (0.045±0.006)

Unit : mm (inch)

概略バリエーション AVAILABLE CAPACITANCE RANGE

BJ/ X7R, BJ/ X5R

Cap [μF]	Type Temp.Char VDC [pF:3digits]	1410 2連 □2K110				2125 2連 □2K212		2125 4連 □4K212				3216 4連 □4K316		
		BJ/ X7R		BJ/ X5R		BJ/ X5R		BJ/ X5R				BJ/ X5R		
		25V	16V	10V	6.3V	10V	6.3V	25V	16V	10V	6.3V	16V	10V	6.3V
0.01	103	B												
0.022	223	B												
0.047	473		B											
0.1	104		B				D	D						
0.22	224			B					D					
0.47	474			A						D				
1.0	105				A	D					D	F	F	F
2.2	225						D							

※グラフ記号は製品厚みを表します。 Letters inside the shaded boxes indicate thickness.

CH/ C0H

Cap [pF]	Type Temp.Char VDC [pF:3digits]	1410 2連 □2K110	
		CH / C0H	50V
		10	100
12	120	B	
15	150	B	
18	180	B	
22	220	B	
27	270	B	
33	330	B	
39	390	B	
47	470	B	
56	560	B	
68	680	B	
82	820	B	
100	101	B	

※グラフ記号は製品厚みを表します。 Letters inside the shaded boxes indicate thickness.

温度特性コード Temp. char.Code	温度特性 Temperature characteristics					静電容量許容差(%) Capacitance tolerance	tanδ(%) Dissipation factor
	準拠規格 Applicable standard		温度範囲(°C) Temperature range	基準温度(°C) Ref. Temp.	静電容量変化率 Capacitance change		
	BJ	JIS	B	-25~85	20		
EIA		X5R	-55~85	25	±15[%]		
EIA		X7R	-55~125	25	±15[%]		
CH	JIS	CH	-55~125	20	±60[ppm/c]	±10(K)	0.1%max.**
	EIA	C0H	-55~125	25	±60[ppm/c]		

* 10% : J2K110, J4K212 3.5% : 110type C<0.1μF

** 27pF以下 Q≥400+20・C 30pF以上 Q≥1000

セレクションガイド
Selection Guide

アイテム一覧
Part Numbers

特性図
Electrical Characteristics

梱包
Packaging

信頼性
Reliability Data

使用上の注意
Precautions



etc

アイテム一覧 PART NUMBERS

■1410TYPE (0504 case size) 2連タイプ (2 circuit type)

定格電圧 Rated Voltage	形名 Ordering code	公称静電容量 Capacitance [μF]	温度特性 Temperature characteristics	tan δ Dissipation factor[%]Max.	実装条件 Soldering method R:リフロー Reflow soldering W:フロ- Wave soldering	静電容量許容差 Capacitance tolerance	厚み Thickness [mm](inch)
25V	T2K110 BJ103□B	0.01	B/X7R	3.5	R	±20%[M] ±10%[K]	0.6±0.06 (0.024±0.002)
	T2K110 BJ223□B	0.022					
16V	E2K110 BJ473□B	0.047		5			
	E2K110 BJ104□B	0.1					
10V	L2K110 BJ224□B	0.22	B/X5R	10	R	±20%[M] ±10%[K]	0.8±0.08 (0.031±0.003)
	L2K110 BJ474MA	0.47					
6.3V	J2K110 BJ105MA*	1.0	X5R				

定格電圧 Rated Voltage	形名 Ordering code	公称静電容量 Capacitance [pF]	温度特性 Temperature characteristics	Q symbol	実装条件 Soldering method R:リフロー Reflow soldering W:フロ- Wave soldering	静電容量許容差 Capacitance tolerance	厚み Thickness [mm](inch)
50V	U2K110 CH100FB	10	CH	400+20・C	R	±10%[K]	0.6±0.06 (0.024±0.002)
	U2K110 CH120KB	12					
	U2K110 CH150KB	15					
	U2K110 CH180KB	18					
	U2K110 CH220KB	22					
	U2K110 CH270KB	27					
	U2K110 CH330KB	33		1000 (0.1%)			
	U2K110 CH390KB	39					
	U2K110 CH470KB	47					
	U2K110 CH560KB	56					
	U2K110 CH680KB	68					
	U2K110 CH820KB	82					
U2K110 CH101KB	100						

■2125TYPE (0805 case size) 4連タイプ (4 circuit type)

定格電圧 Rated Voltage	形名 Ordering code	公称静電容量 Capacitance [μF]	温度特性 Temperature characteristics	tan δ Dissipation factor[%]Max.	実装条件 Soldering method R:リフロー Reflow soldering W:フロ- Wave soldering	静電容量許容差 Capacitance tolerance	厚み Thickness [mm](inch)
25V	T4K212 BJ104□D	0.1	B/X5R	5	R	±20%[M] ±10%[K]	0.85±0.1 (0.033±0.004)
16V	E4K212 BJ104□D	0.1					
10V	L4K212 BJ224□D	0.22					
	L4K212 BJ474□D	0.47					
6.3V	J4K212 BJ105□D*	1.0	X5R	10			

■2125TYPE (0805 case size) 2連タイプ (2 circuit type)

定格電圧 Rated Voltage	形名 Ordering code	公称静電容量 Capacitance [μF]	温度特性 Temperature characteristics	tan δ Dissipation factor[%]Max.	実装条件 Soldering method R:リフロー Reflow soldering W:フロ- Wave soldering	静電容量許容差 Capacitance tolerance	厚み Thickness [mm](inch)
10V	L2K212 BJ105MD	1.0	B/X5R	5	R	±20%[M]	0.85±0.1 (0.033±0.004)
6.3V	J2K212 BJ225MD*	2.2	X5R	10			

■3216TYPE (1206 case size) 4連タイプ (4 circuit type)

定格電圧 Rated Voltage	形名 Ordering code	公称静電容量 Capacitance [μF]	温度特性 Temperature characteristics	tan δ Dissipation factor[%]Max.	実装条件 Soldering method R:リフロー Reflow soldering W:フロ- Wave soldering	静電容量許容差 Capacitance tolerance	厚み Thickness [mm](inch)
16V	E4K316 BJ105□F*	1.0	B/X5R	5	R	±20%[M] ±10%[K]	1.15±0.15 (0.045±0.006)
10V	L4K316 BJ105□F						
6.3V	J4K316 BJ105□F						

形名の□には静電容量許容差記号が入ります。

□ Please specify the capacitance tolerance code.

*高温負荷試験の試験電圧は定格電圧の1.5倍

*Test voltage of Loading at high temperature test is 1.5 time of the rated voltage.

インピーダンス・ESR-周波数特性例 Example of Impedance ESR vs. Frequency characteristics

・当社積層セラミックコンデンサ例 (Taiyo Yuden multilayer ceramic capacitor)

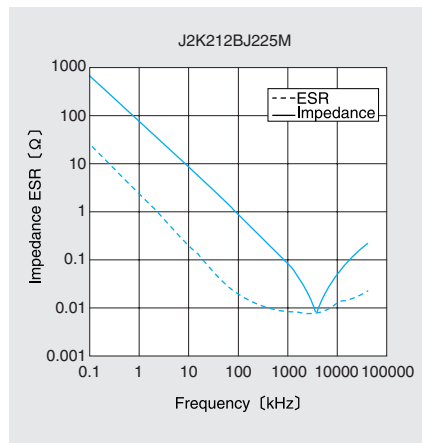
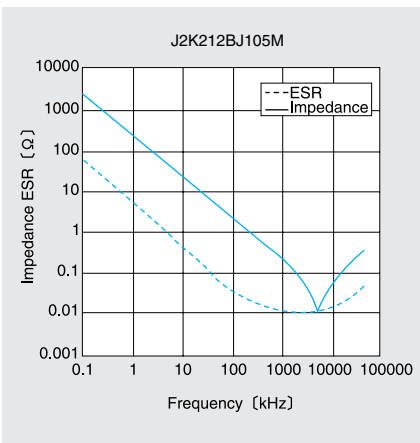
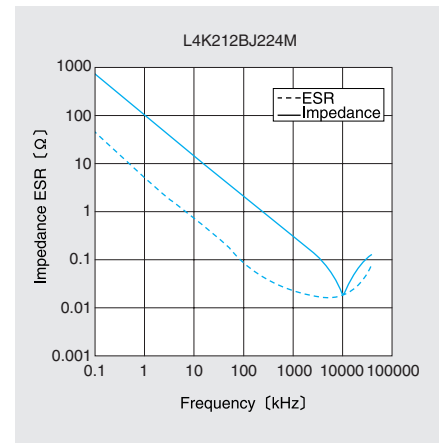
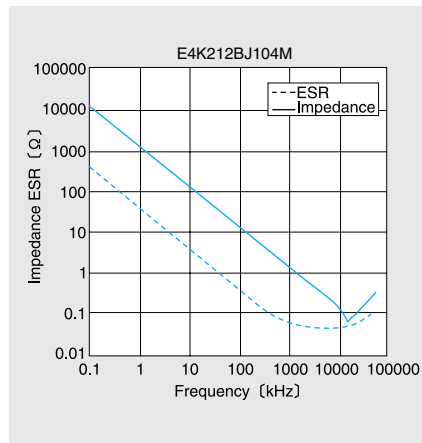
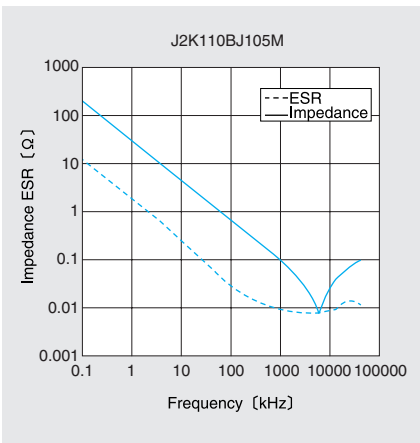
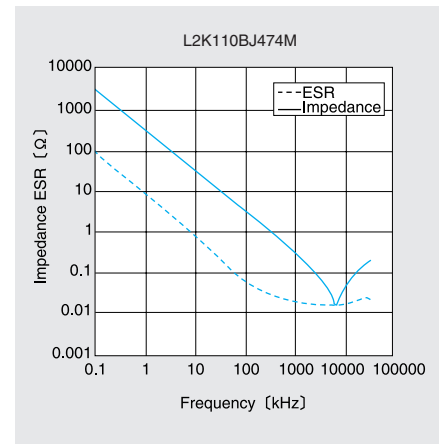
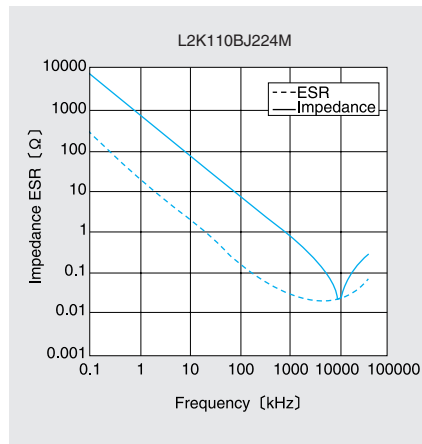
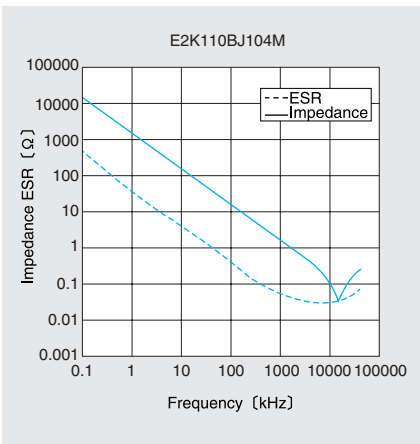
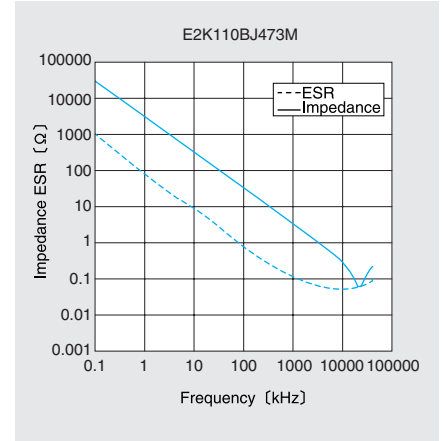
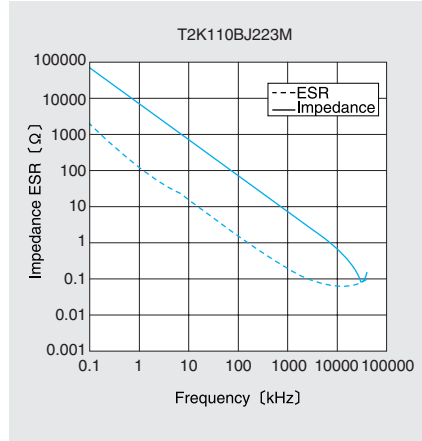
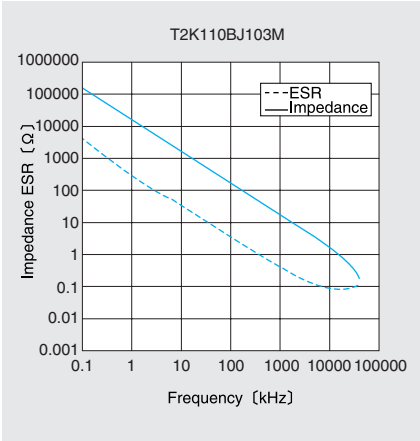

梱包 PACKAGING

①最小受注単位数 Minimum Quantity

■袋づめ梱包 Bulk packaging

形式(EIA) Type	製品厚み Thickness		標準数量 Standard quantity [pcs]
	mm(inch)	code	
□MK105(0402)	0.5 (0.020)	V, W	1000
U VK105(0402)		W	
□MK107(0603)	0.8 (0.031)	A	
		Z	
□2K110(0504)	0.8 (0.031)	A	
	0.6 (0.024)	B	
	0.85 (0.033)	D	
□MK212(0805)	1.25 (0.049)	G	
□4K212(0805)	0.85 (0.033)	D	
□2K212(0805)	0.85 (0.033)	D	
□MK316(1206)	0.85 (0.033)	D	
	1.15 (0.045)	F	
	1.25 (0.049)	G	
	1.6 (0.063)	L	
□MK325(1210)	0.85 (0.033)	D	
	1.15 (0.045)	F	
	1.5 (0.059)	H	
	1.9 (0.075)	N	
	2.0max (0.079)	Y	
	2.5 (0.098)	M	

■テーピング梱包 Taped packaging

形式(EIA) Type	製品厚み Thickness		標準数量 Standard quantity [pcs]	
	mm(inch)	code	紙テープ paper	エンボステープ Embossed tape
□MK063(0201)	0.3 (0.012)	P	15000	—
□MK105(0402)	0.5 (0.020)	V, W	10000	—
U VK105(0402)		W		
□MK107(0603)	0.5 (0.020)	V	4000	—
	0.45 (0.018)	K	4000	—
	0.8 (0.031)	A	4000	—
□2K110(0504)	0.8 (0.031)	Z	4000	—
	0.8 (0.031)	A	4000	—
□2K110(0504)	0.6 (0.024)	B	4000	—
	0.45 (0.018)	K	4000	—
□MK212(0805)	0.85 (0.033)	D	4000	—
	1.25 (0.049)	G	—	3000
□4K212(0805)	0.85 (0.033)	D	4000	—
□2K212(0805)	0.85 (0.033)	D	4000	—
□MK316(1206)	0.85 (0.033)	D	4000	—
	1.15 (0.045)	F	—	3000
	1.25 (0.049)	G	—	3000
□4K316(1206)	1.6 (0.063)	L	—	2000
	0.85 (0.033)	D	—	2000
	1.15 (0.045)	F	—	2000
	1.5 (0.059)	H	—	2000
□MK325(1210)	1.9 (0.075)	N	—	2000
	2.0max (0.079)	Y	—	2000
	2.5 (0.098)	M	—	500
□MK432(1812)	1.9 (0.075)	Y	—	1000
	2.5 (0.098)	M	—	500
	3.2 (0.125)	U	—	500

②テーピング材質 Taping material

紙テープ Card board carrier tape

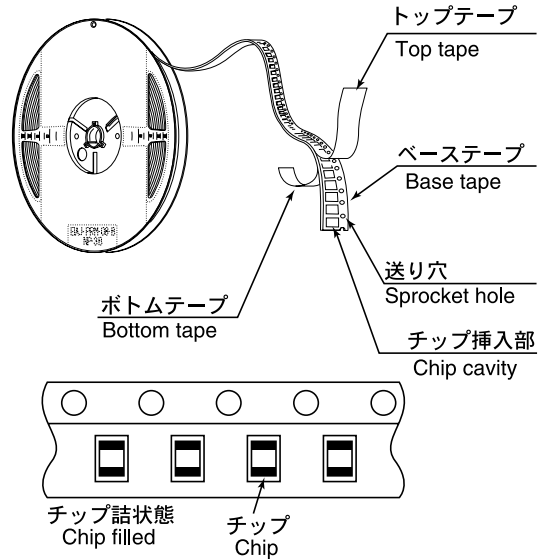

エンボステープ Embossed Tape

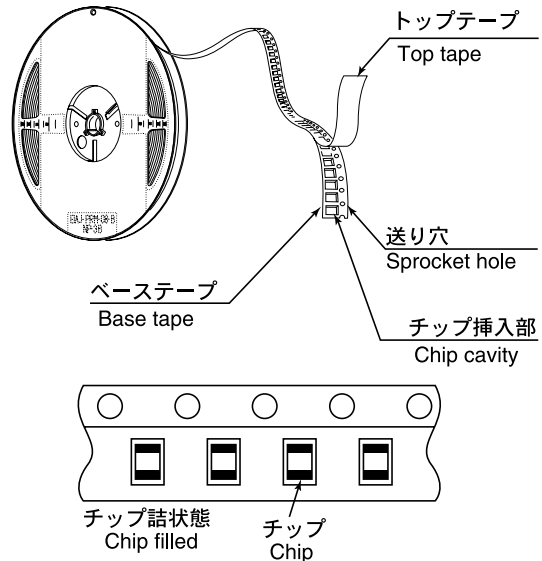

③バルクカセット Bulk Cassette

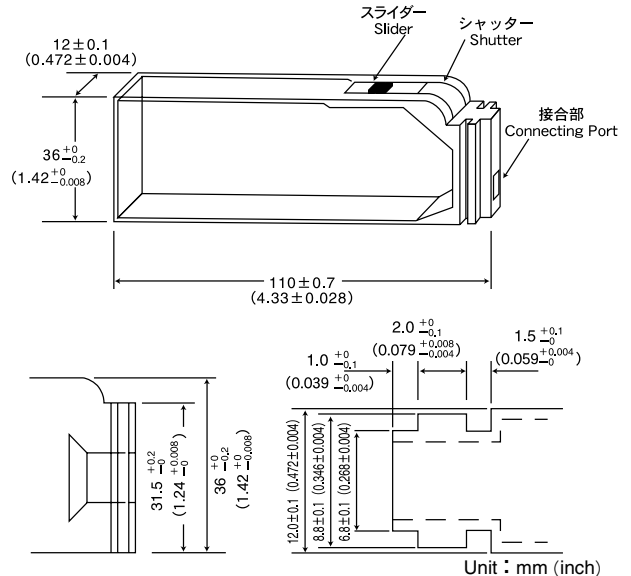

105, 107, 212形状で個別対応致しますのでお問い合わせ下さい。
Please contact any of our offices for accepting your requirement according to dimensions 0402, 0603, 0805.(inch)

③テーピング寸法 Taping dimensions
紙テープ Paper Tape (8mm幅) (0.315inches wide)

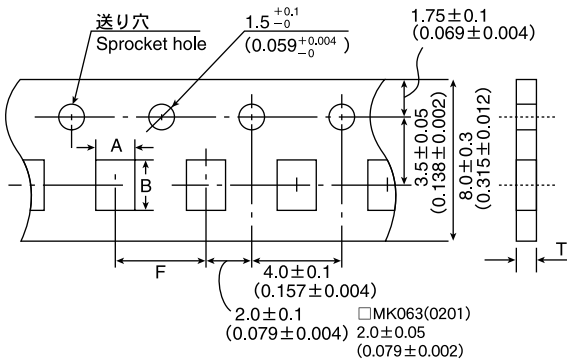

Type (EIA)	チップ挿入部 Chip Cavity		挿入ピッチ Insertion Pitch F	テープ厚み Tape Thickness	
	A	B		K	T
□MK063(0201)	0.37±0.06 (0.06±0.002)	0.67±0.06 (0.027±0.002)	2.0±0.05 (0.079±0.002)	0.45max. (0.018max.)	
□MK105(0402) U VK105(0402)	0.65±0.1 (0.026±0.004)	1.15±0.1 (0.045±0.004)	2.0±0.05 (0.079±0.002)	0.8max. (0.031max.)	
□MK107(0603)	1.0±0.2 (0.039±0.008)	1.8±0.2 (0.071±0.008)	4.0±0.1 (0.157±0.004)	1.1max. (0.043max.)	
□2K110(0504)	1.15±0.2 (0.045±0.008)	1.55±0.2 (0.061±0.008)	4.0±0.1 (0.157±0.004)	1.0max. (0.039max.)	
□MK212(0805)	1.65±0.2 (0.065±0.008)	2.4±0.2 (0.094±0.008)	4.0±0.1 (0.157±0.004)	1.1max. (0.043max.)	
□4K212(0805)					
□2K212(0805)					
□MK316(1206)	2.0±0.2 (0.079±0.008)	3.6±0.2 (0.142±0.008)			

エンボステープ Embossed tape (8mm幅) (0.315inches wide)

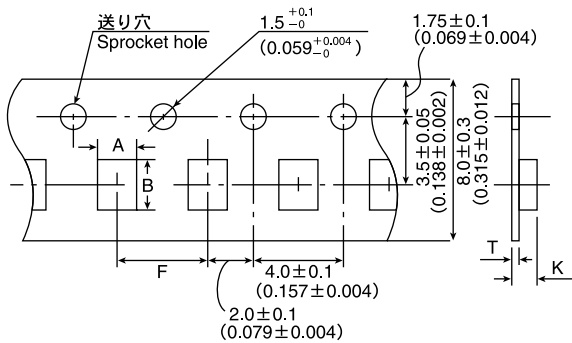

Type (EIA)	チップ挿入部 Chip cavity		挿入ピッチ Insertion Pitch F	テープ厚み Tape Thickness	
	A	B		K	T
□MK212(0805)	1.65±0.2 (0.065±0.008)	2.4±0.2 (0.094±0.008)	4.0±0.1 (0.157±0.004)		
□MK316(1206)	2.0±0.2 (0.079±0.008)	3.6±0.2 (0.142±0.008)		2.5max. (0.098max.)	0.6max. (0.024max.)
□4K316(1206)	2.0±0.2 (0.079±0.008)	3.6±0.2 (0.142±0.008)		3.4max. (0.134max.)	
□MK325(1210)	2.8±0.2 (0.110±0.008)	3.6±0.2 (0.142±0.008)			

Unit : mm(inch)

エンボステープ Embossed tape (12mm幅) (0.472inches wide)

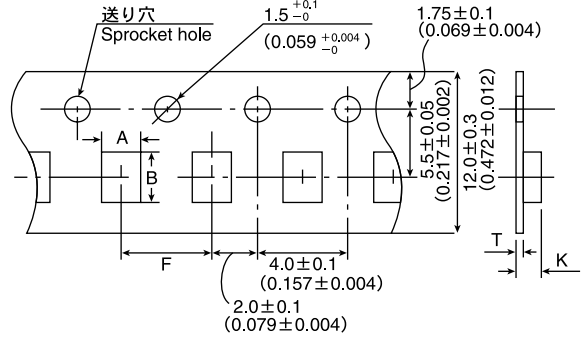

Type (EIA)	チップ挿入部 Chip cavity		挿入ピッチ Insertion Pitch F	テープ厚み Tape Thickness	
	A	B		K	T
□MK432(1812)	3.7±0.2 (0.146±0.008)	4.9±0.2 (0.193±0.008)	8.0±0.1 (0.315±0.004)	4.0max. (0.157max.)	0.6max. (0.024max.)

Unit : mm(inch)

④リーダー部/空部 Leader and Blank portion

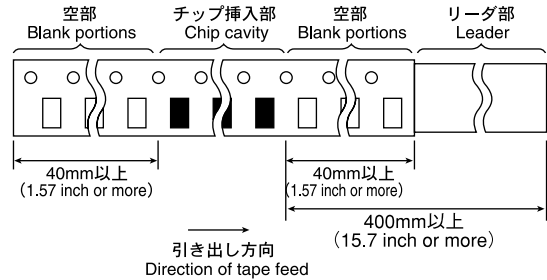

⑤リール寸法 Reel size

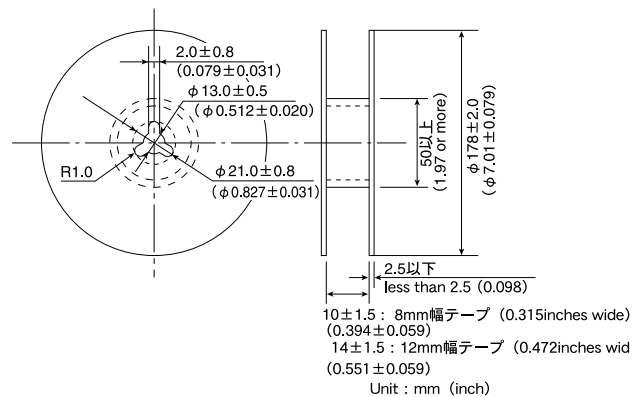

⑥トップテープ強度 Top Tape Strength

トップテープのはがし力は下図矢印方向にて0.1~0.7Nとなります。
The top tape requires a peel-off force of 0.1~0.7N in the direction of the arrow as illustrated below.

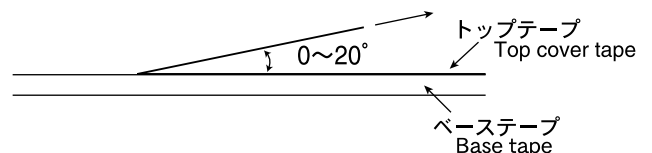

Multilayer Ceramic Capacitor Chips

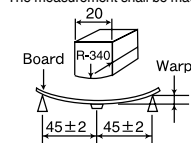
Item	Specified Value				Test Methods and Remarks
	Temperature Compensating (Class 1)		High Permittivity (Class 2)		
	Standard	High Frequency Type	Standard Note1	High Value	
1. Operating Temperature Range	-55 to +125°C		B : -55 to +125°C F : -25 to +85°C	-25 to +85°C	High Capacitance Type BJ(X7R) : -55~+125°C, BJ(X5R) : -55~+85°C C(X5S) : -55~+85°C, C(X6S) : -55~+105°C E(Y5U) : -30~+85°C, F(Y5V) : -30~+85°C
2. Storage Temperature Range	-55 to +125°C		B : -55 to +125°C F : -25 to +85°C	-25 to +85°C	High Capacitance Type BJ(X7R) : -55~+125°C, BJ(X5R) : -55~+85°C C(X5S) : -55~+85°C, C(X6S) : -55~+105°C E(Y5U) : -30~+85°C, F(Y5V) : -30~+85°C
3. Rated Voltage	50VDC, 25VDC, 16VDC	16VDC	50VDC, 25VDC	50VDC, 35VDC, 25VDC 16VDC, 10VDC, 6.3VDC 4DVC	
4. Withstanding Voltage Between terminals	No breakdown or damage	No abnormality	No breakdown or damage		Applied voltage: Rated voltage×3 (Class 1) Rated voltage×2.5 (Class 2) Duration: 1 to 5 sec. Charge/discharge current: 50mA max. (Class 1,2)
5. Insulation Resistance	10000 MΩ min.		500 MΩ μF. or 10000 MΩ., whichever is the smaller. Note 5		Applied voltage: Rated voltage Duration: 60±5 sec. Charge/discharge current: 50mA max.
6. Capacitance (Tolerance)	0.5 to 5 pF: ±0.25 pF 1 to 10pF: ±0.5 pF 5 to 10 pF: ±1 pF 11 pF or over: ± 5% ±10% 105TYPERΔ, SΔ, TΔ, UΔ only 0.5~2pF: ±0.1pF 2.2~20pF: ±5%	0.5 to 2 pF : ±0.1 pF 2.2 to 5.1 pF : ±5%	B: ±10%, ±20% F: $\begin{matrix} +80 \\ -20 \end{matrix}$ %	B : ±10%、±20% C : ±10%、±20% E : -20%/+80% F : -20%/+80%	Measuring frequency : Class 1 : 1MHz±10%(C≤1000pF) 1 k Hz±10%(C>1000pF) Class 2 : 1 k Hz±10%(C≤22μF) 120Hz±10Hz(C>22μF) Measuring voltage : Class 1 : 0.5~5Vrms(C≤1000pF) 1±0.2Vrms(C>1000pF) Class 2 : 1±0.2Vrms(C≤22μF) 0.5±0.1Vrms(C>22μF) Bias application: None
7. Q or Tangent of Loss Angle (tan δ)	Under 30 pF : Q≥400 + 20C 30 pF or over : Q≥1000 C= Nominal capacitance	Refer to detailed specification	B: 2.5% max. (50V, 25V) F: 5.0% max. (50V, 25V)	B : 2.5% max. C、E、F : 7% max. Note 4	Multilayer: Measuring frequency : Class 1 : 1MHz±10%(C≤1000pF) 1 k Hz±10%(C>1000pF) Class 2 : 1 k Hz±10%(C≤22μF) 120Hz±10Hz(C>22μF) Measuring voltage : Class 1 : 0.5~5Vrms(C≤1000pF) 1±0.2Vrms(C>1000pF) Class 2 : 1±0.2Vrms(C≤22μF) 0.5±0.1Vrms(C>22μF) Bias application: None High-Frequency-Multilayer: Measuring frequency: 1GHz Measuring equipment: HP4291A Measuring jig: HP16192A
8. Temperature Characteristic of Capacitance	(Without voltage application) CK : 0±250 CJ : 0±120 CH : 0±60 CG : 0±30 PK : -150±250 PJ : -150±120 PH : -150±60 RK : -220±250 RJ : -220±120 RH : -220±60 SK : -330±250 SJ : -330±120 SH : -330±60 TK : -470±250 TJ : -470±120 TH : -470±60 UK : -750±250 UJ : -750±120 SL : +350 to -1000 (ppm/°C)	CH : 0±60 RH : -220±60 (ppm/°C)	B : ±10%(-25~85°C) F : $\begin{matrix} +30 \\ -80 \end{matrix}$ %(-25~85°C) B(X7R) : ±15% F(Y5V) : $\begin{matrix} +22 \\ -82 \end{matrix}$ %	B : ±10% (-25~+85°C) C : ±20% (-25~+85°C) E : +20%/ -55% (-25~+85°C) F : +30%/ -80% (-25~+85°C) B(X7R、X5R) : ±15% C(X5S、X6S) : ±22% E(Y5U) : +22%/ -56% F(Y5V) : +22%/ -82%	According to JIS C 5102 clause 7.12. Temperature compensating: Measurement of capacitance at 20°C and 85°C shall be made to calculate temperature characteristic by the following equation. $\frac{C_{85} - C_{20}}{C_{20} \times \Delta T} \times 10^{-6} \text{ (ppm/°C)}$ High permittivity: Change of maximum capacitance deviation in step 1 to 5 Temperature at step 1: +20°C Temperature at step 2: minimum operating temperature Temperature at step 3: +20°C (Reference temperature) Temperature at step 4: maximum operating temperature Temperature at step 5: +20°C Reference temperature for X7R, X5R, X5S, X6S, Y5U and Y5V shall be +25°C
9. Resistance to Flexure of Substrate	Appearance: No abnormality Capacitance change: Within ±5% or ±0.5 pF, whichever is larger.	Appearance: No abnormality Capacitance change: Within ±0.5 pF	Appearance: No abnormality Capacitance change: B, BJ, C: Within ±12.5% E, F: Within ±30%	Warp: 1mm Testing board: glass epoxy-resin substrate Thickness: 1.6mm (063 TYPE : 0.8mm) The measurement shall be made with board in the bent position.  (Unit: mm)	

Multilayer Ceramic Capacitor Chips

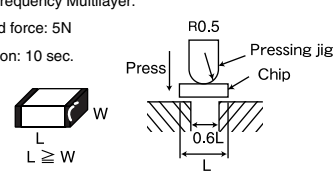
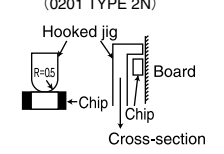
Item	Specified Value				Test Methods and Remarks
	Temperature Compensating (Class 1)		High Permittivity (Class 2)		
	Standard	High Frequency Type	Standard Note1	High Value	
10.Body Strength	—	No mechanical damage.	—	—	High Frequency Multilayer: Applied force: 5N Duration: 10 sec. 
11.Adhesion of Electrode	No separation or indication of separation of electrode.				Applied force: 5N Duration: 30±5 sec. (0201 TYPE 2N) 
12.Solderability	At least 95% of terminal electrode is covered by new solder.				Solder temperature: 230±5°C Duration: 4±1 sec.
13.Resistance to soldering	Appearance: No abnormality Capacitance change: Within ± 2.5% or ±0.25pF, whichever is larger. Q: Initial value Insulation resistance: Initial value Withstanding voltage (between terminals): No abnormality	Appearance: No abnormality Capacitance change: Within ±2.5% Q: Initial value Insulation resistance: Initial value Withstanding voltage (between terminals): No abnormality	Appearance: No abnormality Capacitance change: Within ±7.5% (B, BJ) Within ±15% (C) Within ±20% (E, F) tan δ: Initial value Note 4 Insulation resistance: Initial value Withstanding voltage (between terminals): No abnormality	Preconditioning: Thermal treatment (at 150°C for 1 hr) (Applicable to Class 2.) Solder temperature: 270±5°C Duration: 3±0.5 sec. Preheating conditions: 80 to 100°C, 2 to 5 min. or 5 to 10 min. 150 to 200°C, 2 to 5 min. or 5 to 10 min. Recovery: Recovery for the following period under the standard condition after the test. 24±2 hrs (Class 1) 48±4 hrs (Class 2)	
14.Thermal shock	Appearance: No abnormality Capacitance change: Within ± 2.5% or ±0.25pF, whichever is larger. Q: Initial value Insulation resistance: Initial value Withstanding voltage (between terminals): No abnormality	Appearance: No abnormality Capacitance change: Within ±0.25pF Q: Initial value Insulation resistance: Initial value Withstanding voltage (between terminals): No abnormality	Appearance: No abnormality Capacitance change: Within ±7.5% (B, BJ) Within ±15% (C) Within ±20% (E, F) tan δ: Initial value Note 4 Insulation resistance: Initial value Withstanding voltage (between terminals): No abnormality	Preconditioning: Thermal treatment (at 150°C for 1 hr) (Applicable to Class 2.) Conditions for 1 cycle: Step 1: Minimum operating temperature -3°C 30±3 min. Step 2: Room temperature 2 to 3 min. Step 3: Maximum operating temperature $+3^{\circ}\text{C}$ 30±3 min. Step 4: Room temperature 2 to 3 min. Number of cycles: 5 times Recovery after the test: 24±2 hrs (Class 1) 48±4 hrs (Class 2)	
15.Damp Heat (steady state)	Appearance: No abnormality Capacitance change: Within ±5% or ±0.5pF, whichever is larger. Q: $C \geq 30 \text{ pF} : Q \geq 350$ $10 \leq C < 30 \text{ pF} : Q \geq 275 + 2.5C$ $C < 10 \text{ pF} : Q \geq 200 + 10C$ C: Nominal capacitance Insulation resistance: 1000 MΩ min.	Appearance: No abnormality Capacitance change: Within ±0.5pF, Insulation resistance: 1000 MΩ min.	Appearance: No abnormality Capacitance change: B: Within ±12.5% F: Within ±30% tan δ: B: 5.0% max. F: 7.5% max. Note 4 Insulation resistance: 50 MΩ μF or 1000 MΩ whichever is smaller. Note 5	Appearance: No abnormality Capacitance change: BJ: Within ±12.5% C(X6S) Within ±25% C(X5S),E,F Within ±30% tan δ: Note 4 BJ: 5.0% max. C, E, F: 11.0% max. Insulation resistance: 50 MΩ μF or 1000 MΩ whichever is smaller. Note 5	Multilayer : Preconditioning: Thermal treatment (at 150°C for 1 hr) (Applicable to Class 2.) Temperature: 40±2°C Humidity: 90 to 95% RH Duration: 500 $^{+24}_{-0}$ hrs Recovery: Recovery for the following period under the standard condition after the removal from test chamber. 24±2 hrs (Class 1) 48±4 hrs (Class 2) High-Frequency Multilayer: Temperature: 60±2°C Humidity: 90 to 95% RH Duration: 500 $^{+24}_{-0}$ hrs Recovery: Recovery for the following period under the standard condition after the removal from test chamber. 24±2 hrs (Class 1)

Multilayer Ceramic Capacitor Chips





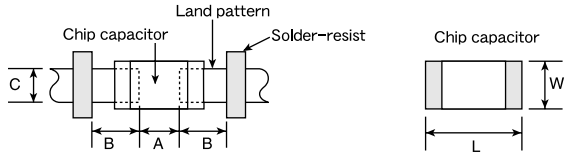
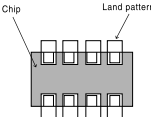
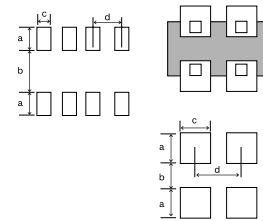

Item	Specified Value				Test Methods and Remarks
	Temperature Compensating (Class 1)		High Permittivity (Class 2)		
	Standard	High Frequency Type	Standard Note1	High Value	
16.Loading under Damp Heat	Appearance: No abnormality Capacitance change: Within $\pm 7.5\%$ or $\pm 0.75\text{pF}$, whichever is larger. Q: $C \geq 30\text{ pF}$; $Q \geq 200$ $C < 30\text{ pF}$; $Q \geq 100 + 10C/3$ C: Nominal capacitance Insulation resistance: 500 M Ω min.	Appearance: No abnormality Capacitance change: $C \leq 2\text{ pF}$: Within $\pm 0.4\text{ pF}$ $C > 2\text{ pF}$: Within $\pm 0.75\text{ pF}$ C: Nominal capacitance Insulation resistance: 500 M Ω min.	Appearance: No abnormality Capacitance change: B: Within $\pm 12.5\%$ F: Within $\pm 30\%$ $\tan \delta$: B: 5.0% max. F: 7.5% max. Note 4 Insulation resistance: 25 M Ω μF or 500 M Ω , whichever is the smaller. Note 5	Appearance: No abnormality Capacitance change: BJ: Within $\pm 12.5\%$ C, E, F: Within $\pm 30\%$ $\tan \delta$: Note 4 BJ: 5.0% max. C, E, F: 11% max. Insulation resistance: 25 M Ω μF or 500 M Ω , whichever is the smaller. Note 5	According to JIS C 5102 Clause 9. 9. Multilayer: Preconditioning: Voltage treatment (Class 2) Temperature: 40 $\pm 2^\circ\text{C}$ Humidity: 90 to 95% RH Duration: 500 $^{+24}_{-0}$ hrs Applied voltage: Rated voltage Charge and discharge current: 50mA max. (Class 1,2) Recovery: Recovery for the following period under the standard condition after the removal from test chamber. 24 ± 2 hrs (Class 1) 48 ± 4 hrs (Class 2) High-Frequency Multilayer: Temperature: 60 $\pm 2^\circ\text{C}$ Humidity: 90 to 95% RH Duration: 500 $^{+24}_{-0}$ hrs Applied voltage: Rated voltage Charge and discharge current: 50mA max. Recovery: 24 ± 2 hrs of recovery under the standard condition after the removal from test chamber.
17.Loading at High Temperature	Appearance: No abnormality Capacitance change: Within $\pm 3\%$ or $\pm 0.3\text{pF}$, whichever is larger. Q: $C \geq 30\text{ pF}$; $Q \geq 350$ $10 \leq C < 30\text{ pF}$; $Q \geq 275 + 2.5C$ $C < 10\text{ pF}$; $Q \geq 200 + 10C$ C: Nominal capacitance Insulation resistance: 1000 M Ω min.	Appearance: No abnormality Capacitance change: Within $\pm 3\%$ or $\pm 0.3\text{pF}$, whichever is larger. Insulation resistance: 1000 M Ω min.	Appearance: No abnormality Capacitance change: B: Within $\pm 12.5\%$ F: Within $\pm 30\%$ $\tan \delta$: Note 4 B: 4.0% max. F: 7.5% max. Insulation resistance: 50 M Ω μF or 1000 M Ω , whichever is smaller. Note 5	Appearance: No abnormality Capacitance change: BJ: Within $\pm 12.5\%$ Within $\pm 20\% \text{※※}$ Within $\pm 25\% \text{※※}$ C: Within $\pm 25\% \text{(X6S)}$ Within $\pm 30\% \text{(X5S)}$ E, F: Within $\pm 30\%$ $\tan \delta$: Note 4 BJ: 5.0% max. C, F, F: 11% max. Insulation resistance: 50 M Ω μF or 1000 M Ω , whichever is smaller. Note 5	According to JIS C 5102 clause 9.10. Multilayer: Preconditioning: Voltage treatment (Class 2) Temperature: 125 $\pm 3^\circ\text{C}$ (Class 1, Class 2: B, BJ(X7R)) 85 $\pm 2^\circ\text{C}$ (Class 2: BJ, F) Duration: 1000 $^{+48}_{-0}$ hrs Applied voltage: Rated voltage $\times 2$ Note 6 Recovery: Recovery for the following period under the standard condition after the removal from test chamber. As for Ni product, thermal treatment shall be performed prior to the recovery. 24 ± 2 hrs (Class 1) 48 ± 4 hrs (Class 2) High-Frequency Multilayer: Temperature: 125 $\pm 3^\circ\text{C}$ (Class 1) Duration: 1000 $^{+48}_{-0}$ hrs Applied voltage: Rated voltage $\times 2$ Recovery: 24 ± 2 hrs of recovery under the standard condition after the removal from test chamber.

Note 1 :For 105 type, specified in "High value".
 Note 2 :Thermal treatment (Multilayer): 1 hr of thermal treatment at 150 ± 0 / -10 $^\circ\text{C}$ followed by 48 ± 4 hrs of recovery under the standard condition shall be performed before the measurement.
 Note 3 :Voltage treatment (Multilayer): 1 hr of voltage treatment under the specified temperature and voltage for testing followed by 48 ± 4 hrs of recovery under the standard condition shall be performed before the measurement.
 Note 4, 5 :The figure indicates typical inspection. Please refer to individual specifications.
 Note 6 :Some of the parts are applicable in rated voltage $\times 1.5$. Please refer to individual specifications.
 Note on standard condition: "standard condition" referred to herein is defined as follows: 5 to 35 $^\circ\text{C}$ of temperature, 45 to 85% relative humidity, and 86 to 106kPa of air pressure.
 When there are questions concerning measurement results: In order to provide correlation data, the test shall be conducted under condition of 20 $\pm 2^\circ\text{C}$ of temperature, 65 to 70% relative humidity, and 86 to 106kPa of air pressure. Unless otherwise specified, all the tests are conducted under the "standard condition."

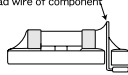
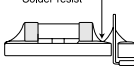
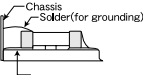
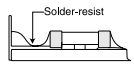
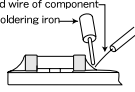
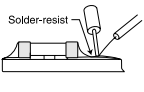
Precautions on the use of Multilayer Ceramic Capacitors

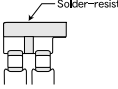
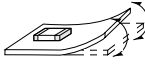
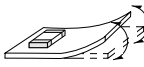
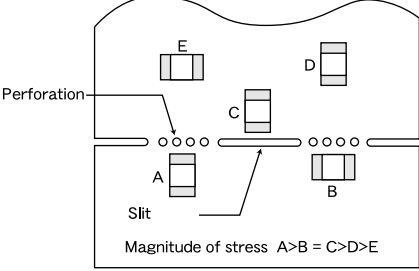
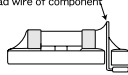
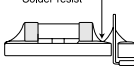
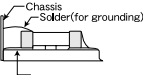
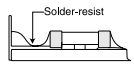
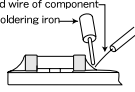
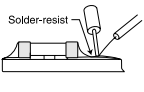
Stages	Precautions	Technical considerations																																																																																																																								
1.Circuit Design	<p>Verification of operating environment, electrical rating and performance</p> <p>1. A malfunction in medical equipment, spacecraft, nuclear reactors, etc. may cause serious harm to human life or have severe social ramifications. As such, any capacitors to be used in such equipment may require higher safety and/or reliability considerations and should be clearly differentiated from components used in general purpose applications.</p> <p>Operating Voltage (Verification of Rated voltage)</p> <p>1. The operating voltage for capacitors must always be lower than their rated values.</p> <p>If an AC voltage is loaded on a DC voltage, the sum of the two peak voltages should be lower than the rated value of the capacitor chosen. For a circuit where both an AC and a pulse voltage may be present, the sum of their peak voltages should also be lower than the capacitor's rated voltage.</p> <p>2. Even if the applied voltage is lower than the rated value, the reliability of capacitors might be reduced if either a high frequency AC voltage or a pulse voltage having rapid rise time is present in the circuit.</p>																																																																																																																									
2.PCB Design	<p>Pattern configurations (Design of Land-patterns)</p> <p>1. When capacitors are mounted on a PCB, the amount of solder used (size of fillet) can directly affect capacitor performance. Therefore, the following items must be carefully considered in the design of solder land patterns:</p> <p>(1) The amount of solder applied can affect the ability of chips to withstand mechanical stresses which may lead to breaking or cracking. Therefore, when designing land-patterns it is necessary to consider the appropriate size and configuration of the solder pads which in turn determines the amount of solder necessary to form the fillets.</p> <p>(2) When more than one part is jointly soldered onto the same land or pad, the pad must be designed so that each component's soldering point is separated by solder-resist.</p>	<p>1.The following diagrams and tables show some examples of recommended patterns to prevent excessive solder amounts.(larger fillets which extend above the component end terminations)</p> <p>Examples of improper pattern designs are also shown.</p> <p>(1) Recommended land dimensions for a typical chip capacitor land patterns for PCBs</p>  <p>Recommended land dimensions for wave-soldering (unit: mm)</p> <table border="1" data-bbox="849 1249 1230 1432"> <thead> <tr> <th>Type</th> <th>107</th> <th>212</th> <th>316</th> <th>325</th> </tr> </thead> <tbody> <tr> <td rowspan="2">Size</td> <td>L</td> <td>1.6</td> <td>2.0</td> <td>3.2</td> </tr> <tr> <td>W</td> <td>0.8</td> <td>1.25</td> <td>1.6</td> </tr> <tr> <td>A</td> <td>0.8~1.0</td> <td>1.0~1.4</td> <td>1.8~2.5</td> <td>1.8~2.5</td> </tr> <tr> <td>B</td> <td>0.5~0.8</td> <td>0.8~1.5</td> <td>0.8~1.7</td> <td>0.8~1.7</td> </tr> <tr> <td>C</td> <td>0.6~0.8</td> <td>0.9~1.2</td> <td>1.2~1.6</td> <td>1.8~2.5</td> </tr> </tbody> </table> <p>Recommended land dimensions for reflow-soldering (unit: mm)</p> <table border="1" data-bbox="849 1502 1382 1686"> <thead> <tr> <th>Type</th> <th>063</th> <th>105</th> <th>107</th> <th>212</th> <th>316</th> <th>325</th> <th>432</th> </tr> </thead> <tbody> <tr> <td rowspan="2">Size</td> <td>L</td> <td>0.6</td> <td>1.0</td> <td>1.6</td> <td>2.0</td> <td>3.2</td> <td>4.5</td> </tr> <tr> <td>W</td> <td>0.3</td> <td>0.5</td> <td>0.8</td> <td>1.25</td> <td>1.6</td> <td>3.2</td> </tr> <tr> <td>A</td> <td>0.20~0.30</td> <td>0.45~0.55</td> <td>0.6~0.8</td> <td>0.8~1.2</td> <td>1.8~2.5</td> <td>1.8~2.5</td> <td>2.5~3.5</td> </tr> <tr> <td>B</td> <td>0.20~0.30</td> <td>0.40~0.50</td> <td>0.6~0.8</td> <td>0.8~1.2</td> <td>1.0~1.5</td> <td>1.0~1.5</td> <td>1.5~1.8</td> </tr> <tr> <td>C</td> <td>0.25~0.40</td> <td>0.45~0.55</td> <td>0.6~0.8</td> <td>0.9~1.6</td> <td>1.2~2.0</td> <td>1.8~3.2</td> <td>2.3~3.5</td> </tr> </tbody> </table> <p>Excess solder can affect the ability of chips to withstand mechanical stresses. Therefore, please take proper precautions when designing land-patterns.</p> <table border="1" data-bbox="849 1751 1187 1926"> <thead> <tr> <th>Type</th> <th>316 (4 circuits)</th> <th>212 (4 circuits)</th> </tr> </thead> <tbody> <tr> <td rowspan="2">Size</td> <td>L</td> <td>3.2</td> <td>2.0</td> </tr> <tr> <td>W</td> <td>1.6</td> <td>1.25</td> </tr> <tr> <td>a</td> <td>0.7~0.9</td> <td>0.5~0.6</td> </tr> <tr> <td>b</td> <td>1</td> <td>0.5~0.6</td> </tr> <tr> <td>c</td> <td>0.4~0.5</td> <td>0.2~0.3</td> </tr> <tr> <td>d</td> <td>0.8</td> <td>0.5</td> </tr> </tbody> </table>  <table border="1" data-bbox="849 1932 1187 2109"> <thead> <tr> <th>Type</th> <th>212 (2 circuits)</th> <th>110 (2 circuits)</th> </tr> </thead> <tbody> <tr> <td rowspan="2">Size</td> <td>L</td> <td>2.0</td> <td>1.37</td> </tr> <tr> <td>W</td> <td>1.25</td> <td>1.0</td> </tr> <tr> <td>a</td> <td>0.5~0.6</td> <td>0.35~0.45</td> </tr> <tr> <td>b</td> <td>0.5~0.6</td> <td>0.55~0.65</td> </tr> <tr> <td>c</td> <td>0.5~0.6</td> <td>0.3~0.4</td> </tr> <tr> <td>d</td> <td>1.0</td> <td>0.64</td> </tr> </tbody> </table> 	Type	107	212	316	325	Size	L	1.6	2.0	3.2	W	0.8	1.25	1.6	A	0.8~1.0	1.0~1.4	1.8~2.5	1.8~2.5	B	0.5~0.8	0.8~1.5	0.8~1.7	0.8~1.7	C	0.6~0.8	0.9~1.2	1.2~1.6	1.8~2.5	Type	063	105	107	212	316	325	432	Size	L	0.6	1.0	1.6	2.0	3.2	4.5	W	0.3	0.5	0.8	1.25	1.6	3.2	A	0.20~0.30	0.45~0.55	0.6~0.8	0.8~1.2	1.8~2.5	1.8~2.5	2.5~3.5	B	0.20~0.30	0.40~0.50	0.6~0.8	0.8~1.2	1.0~1.5	1.0~1.5	1.5~1.8	C	0.25~0.40	0.45~0.55	0.6~0.8	0.9~1.6	1.2~2.0	1.8~3.2	2.3~3.5	Type	316 (4 circuits)	212 (4 circuits)	Size	L	3.2	2.0	W	1.6	1.25	a	0.7~0.9	0.5~0.6	b	1	0.5~0.6	c	0.4~0.5	0.2~0.3	d	0.8	0.5	Type	212 (2 circuits)	110 (2 circuits)	Size	L	2.0	1.37	W	1.25	1.0	a	0.5~0.6	0.35~0.45	b	0.5~0.6	0.55~0.65	c	0.5~0.6	0.3~0.4	d	1.0	0.64
Type	107	212	316	325																																																																																																																						
Size	L	1.6	2.0	3.2																																																																																																																						
	W	0.8	1.25	1.6																																																																																																																						
A	0.8~1.0	1.0~1.4	1.8~2.5	1.8~2.5																																																																																																																						
B	0.5~0.8	0.8~1.5	0.8~1.7	0.8~1.7																																																																																																																						
C	0.6~0.8	0.9~1.2	1.2~1.6	1.8~2.5																																																																																																																						
Type	063	105	107	212	316	325	432																																																																																																																			
Size	L	0.6	1.0	1.6	2.0	3.2	4.5																																																																																																																			
	W	0.3	0.5	0.8	1.25	1.6	3.2																																																																																																																			
A	0.20~0.30	0.45~0.55	0.6~0.8	0.8~1.2	1.8~2.5	1.8~2.5	2.5~3.5																																																																																																																			
B	0.20~0.30	0.40~0.50	0.6~0.8	0.8~1.2	1.0~1.5	1.0~1.5	1.5~1.8																																																																																																																			
C	0.25~0.40	0.45~0.55	0.6~0.8	0.9~1.6	1.2~2.0	1.8~3.2	2.3~3.5																																																																																																																			
Type	316 (4 circuits)	212 (4 circuits)																																																																																																																								
Size	L	3.2	2.0																																																																																																																							
	W	1.6	1.25																																																																																																																							
a	0.7~0.9	0.5~0.6																																																																																																																								
b	1	0.5~0.6																																																																																																																								
c	0.4~0.5	0.2~0.3																																																																																																																								
d	0.8	0.5																																																																																																																								
Type	212 (2 circuits)	110 (2 circuits)																																																																																																																								
Size	L	2.0	1.37																																																																																																																							
	W	1.25	1.0																																																																																																																							
a	0.5~0.6	0.35~0.45																																																																																																																								
b	0.5~0.6	0.55~0.65																																																																																																																								
c	0.5~0.6	0.3~0.4																																																																																																																								
d	1.0	0.64																																																																																																																								

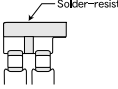
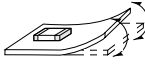
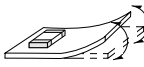
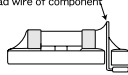
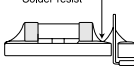
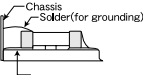
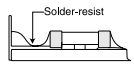
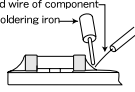
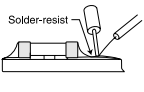
Precautions on the use of Multilayer Ceramic Capacitors

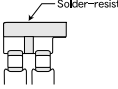
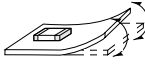
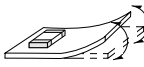
Stages	Precautions	Technical considerations																					
<p>2.PCB Design</p>	<p>Pattern configurations (Capacitor layout on panelized [breakaway] PC boards)</p> <p>1. After capacitors have been mounted on the boards, chips can be subjected to mechanical stresses in subsequent manufacturing processes (PCB cutting, board inspection, mounting of additional parts, assembly into the chassis, wave soldering the reflow soldered boards etc.) For this reason, planning pattern configurations and the position of SMD capacitors should be carefully performed to minimize stress.</p>	<p>(2) Examples of good and bad solder application</p> <table border="1" data-bbox="849 301 1452 746"> <thead> <tr> <th>Items</th> <th>Not recommended</th> <th>Recommended</th> </tr> </thead> <tbody> <tr> <td>Mixed mounting of SMD and leaded components</td> <td></td> <td></td> </tr> <tr> <td>Component placement close to the chassis</td> <td></td> <td></td> </tr> <tr> <td>Hand-soldering of leaded components near mounted components</td> <td></td> <td></td> </tr> <tr> <td>Horizontal component placement</td> <td></td> <td></td> </tr> </tbody> </table> <p>1-1. The following are examples of good and bad capacitor layout; SMD capacitors should be located to minimize any possible mechanical stresses from board warp or deflection.</p> <table border="1" data-bbox="849 847 1452 1000"> <thead> <tr> <th></th> <th>Not recommended</th> <th>Recommended</th> </tr> </thead> <tbody> <tr> <td>Deflection of the board</td> <td></td> <td></td> </tr> </tbody> </table> <p>1-2. To layout the capacitors for the breakaway PC board, it should be noted that the amount of mechanical stresses given will vary depending on capacitor layout. The example below shows recommendations for better design.</p> <div data-bbox="906 1109 1327 1380">  <p>Magnitude of stress $A > B = C > D > E$</p> </div> <p>1-3. When breaking PC boards along their perforations, the amount of mechanical stress on the capacitors can vary according to the method used. The following methods are listed in order from least stressful to most stressful: push-back, slit, V-grooving, and perforation. Thus, any ideal SMD capacitor layout must also consider the PCB splitting procedure.</p>	Items	Not recommended	Recommended	Mixed mounting of SMD and leaded components			Component placement close to the chassis			Hand-soldering of leaded components near mounted components			Horizontal component placement				Not recommended	Recommended	Deflection of the board		
Items	Not recommended	Recommended																					
Mixed mounting of SMD and leaded components																							
Component placement close to the chassis																							
Hand-soldering of leaded components near mounted components																							
Horizontal component placement																							
	Not recommended	Recommended																					
Deflection of the board																							

Precautions on the use of Multilayer Ceramic Capacitors

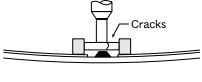
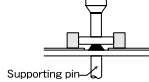
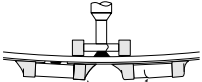
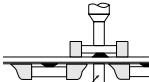
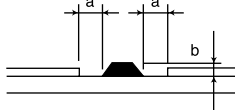
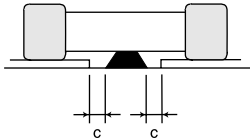
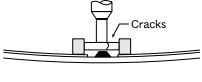
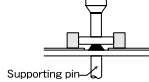
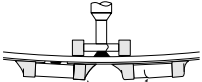
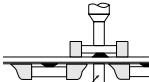
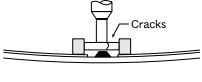
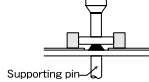
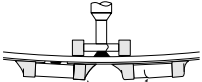
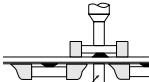
Stages	Precautions	Technical considerations																	
<p>3. Considerations for automatic placement</p>	<p>Adjustment of mounting machine</p> <ol style="list-style-type: none"> Excessive impact load should not be imposed on the capacitors when mounting onto the PC boards. The maintenance and inspection of the mounters should be conducted periodically. <p>Selection of Adhesives</p> <ol style="list-style-type: none"> Mounting capacitors with adhesives in preliminary assembly, before the soldering stage, may lead to degraded capacitor characteristics unless the following factors are appropriately checked; the size of land patterns, type of adhesive, amount applied, hardening temperature and hardening period. Therefore, it is imperative to consult the manufacturer of the adhesives on proper usage and amounts of adhesive to use. 	<ol style="list-style-type: none"> If the lower limit of the pick-up nozzle is low, too much force may be imposed on the capacitors, causing damage. To avoid this, the following points should be considered before lowering the pick-up nozzle: <ol style="list-style-type: none"> The lower limit of the pick-up nozzle should be adjusted to the surface level of the PC board after correcting for deflection of the board. The pick-up pressure should be adjusted between 1 and 3 N static loads. To reduce the amount of deflection of the board caused by impact of the pick-up nozzle, supporting pins or back-up pins should be used under the PC board. The following diagrams show some typical examples of good pick-up nozzle placement: <table border="1" data-bbox="850 526 1452 797"> <thead> <tr> <th></th> <th>Not recommended</th> <th>Recommended</th> </tr> </thead> <tbody> <tr> <td>Single-sided mounting</td> <td></td> <td></td> </tr> <tr> <td>Double-sided mounting</td> <td></td> <td></td> </tr> </tbody> </table> <ol style="list-style-type: none"> As the alignment pin wears out, adjustment of the nozzle height can cause chipping or cracking of the capacitors because of mechanical impact on the capacitors. To avoid this, the monitoring of the width between the alignment pin in the stopped position, and maintenance, inspection and replacement of the pin should be conducted periodically. <ol style="list-style-type: none"> Some adhesives may cause reduced insulation resistance. The difference between the shrinkage percentage of the adhesive and that of the capacitors may result in stresses on the capacitors and lead to cracking. Moreover, too little or too much adhesive applied to the board may adversely affect component placement, so the following precautions should be noted in the application of adhesives. <ol style="list-style-type: none"> Required adhesive characteristics <ol style="list-style-type: none"> The adhesive should be strong enough to hold parts on the board during the mounting & solder process. The adhesive should have sufficient strength at high temperatures. The adhesive should have good coating and thickness consistency. The adhesive should be used during its prescribed shelf life. The adhesive should harden rapidly The adhesive must not be contaminated. The adhesive should have excellent insulation characteristics. The adhesive should not be toxic and have no emission of toxic gasses. The recommended amount of adhesives is as follows; <table border="1" data-bbox="850 1469 1404 1589"> <thead> <tr> <th>Figure</th> <th>212/316 case sizes as examples</th> </tr> </thead> <tbody> <tr> <td>a</td> <td>0.3mm min</td> </tr> <tr> <td>b</td> <td>100 ~ 120 μm</td> </tr> <tr> <td>c</td> <td>Adhesives should not contact the pad</td> </tr> </tbody> </table> <div style="display: flex; justify-content: space-around; margin-top: 20px;"> <div data-bbox="874 1664 1109 1808"> <p>Amount of adhesive</p>  </div> <div data-bbox="1173 1664 1423 1852"> <p>After capacitors are bonded</p>  </div> </div>		Not recommended	Recommended	Single-sided mounting			Double-sided mounting			Figure	212/316 case sizes as examples	a	0.3mm min	b	100 ~ 120 μm	c	Adhesives should not contact the pad
	Not recommended	Recommended																	
Single-sided mounting																			
Double-sided mounting																			
Figure	212/316 case sizes as examples																		
a	0.3mm min																		
b	100 ~ 120 μm																		
c	Adhesives should not contact the pad																		

Precautions on the use of Multilayer Ceramic Capacitors

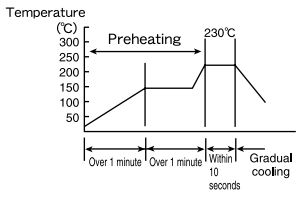
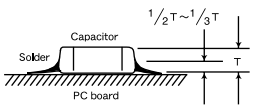
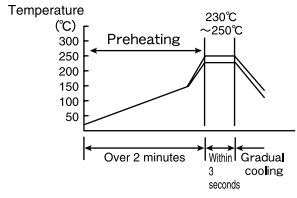
Stages	Precautions	Technical considerations
<p>4. Soldering</p>	<p>Selection of Flux</p> <p>1. Since flux may have a significant effect on the performance of capacitors, it is necessary to verify the following conditions prior to use;</p> <p>(1) Flux used should be with less than or equal to 0.1 wt% (equivalent to chlorine) of halogenated content. Flux having a strong acidity content should not be applied.</p> <p>(2) When soldering capacitors on the board, the amount of flux applied should be controlled at the optimum level.</p> <p>(3) When using water-soluble flux, special care should be taken to properly clean the boards.</p> <p>Soldering</p> <p>Temperature, time, amount of solder, etc. are specified in accordance with the following recommended conditions.</p> <p>And please contact us about peak temperature when you use lead-free paste.</p>	<p>1-1. When too much halogenated substance (Chlorine, etc.) content is used to activate the flux, or highly acidic flux is used, an excessive amount of residue after soldering may lead to corrosion of the terminal electrodes or degradation of insulation resistance on the surface of the capacitors.</p> <p>1-2. Flux is used to increase solderability in flow soldering, but if too much is applied, a large amount of flux gas may be emitted and may detrimentally affect solderability. To minimize the amount of flux applied, it is recommended to use a flux-bubbling system.</p> <p>1-3. Since the residue of water-soluble flux is easily dissolved by water content in the air, the residue on the surface of capacitors in high humidity conditions may cause a degradation of insulation resistance and therefore affect the reliability of the components. The cleaning methods and the capability of the machines used should also be considered carefully when selecting water-soluble flux.</p> <p>1-1. Preheating when soldering</p> <p>Heating: Ceramic chip components should be preheated to within 100 to 130°C of the soldering.</p> <p>Cooling: The temperature difference between the components and cleaning process should not be greater than 100°C.</p> <p>Ceramic chip capacitors are susceptible to thermal shock when exposed to rapid or concentrated heating or rapid cooling. Therefore, the soldering process must be conducted with great care so as to prevent malfunction of the components due to excessive thermal shock.</p> <p>Recommended conditions for soldering</p> <p>[Reflow soldering]</p> <p>Temperature profile</p>  <p>Caution</p> <p>1. The ideal condition is to have solder mass (fillet) controlled to 1/2 to 1/3 of the thickness of the capacitor, as shown below:</p>  <p>2. Because excessive dwell times can detrimentally affect solderability, soldering duration should be kept as close to recommended times as possible.</p> <p>[Wave soldering]</p> <p>Temperature profile</p>  <p>Caution</p> <ol style="list-style-type: none"> 1. Make sure the capacitors are preheated sufficiently. 2. The temperature difference between the capacitor and melted solder should not be greater than 100 to 130°C 3. Cooling after soldering should be as gradual as possible. 4. Wave soldering must not be applied to the capacitors designated as for reflow soldering only.

Precautions on the use of Multilayer Ceramic Capacitors

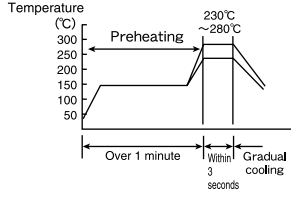
Stages	Precautions	Technical considerations						
4. Soldering		<p>[Hand soldering]</p> <p>Temperature profile</p>  <p>Caution</p> <ol style="list-style-type: none"> 1. Use a 20W soldering iron with a maximum tip diameter of 1.0 mm. 2. The soldering iron should not directly touch the capacitor. 						
5. Cleaning	<p>Cleaning conditions</p> <ol style="list-style-type: none"> 1. When cleaning the PC board after the capacitors are all mounted, select the appropriate cleaning solution according to the type of flux used and purpose of the cleaning (e.g. to remove soldering flux or other materials from the production process.) 2. Cleaning conditions should be determined after verifying, through a test run, that the cleaning process does not affect the capacitor's characteristics. 	<ol style="list-style-type: none"> 1. The use of inappropriate solutions can cause foreign substances such as flux residue to adhere to the capacitor or deteriorate the capacitor's outer coating, resulting in a degradation of the capacitor's electrical properties (especially insulation resistance). 2. Inappropriate cleaning conditions (insufficient or excessive cleaning) may detrimentally affect the performance of the capacitors. <p>(1)Excessive cleaning</p> <p>In the case of ultrasonic cleaning, too much power output can cause excessive vibration of the PC board which may lead to the cracking of the capacitor or the soldered portion, or decrease the terminal electrodes' strength. Thus the following conditions should be carefully checked;</p> <table border="0" data-bbox="906 991 1190 1072"> <tr> <td>Ultrasonic output</td> <td>Below 20 W/ℓ</td> </tr> <tr> <td>Ultrasonic frequency</td> <td>Below 40 kHz</td> </tr> <tr> <td>Ultrasonic washing period</td> <td>5 min. or less</td> </tr> </table>	Ultrasonic output	Below 20 W/ℓ	Ultrasonic frequency	Below 40 kHz	Ultrasonic washing period	5 min. or less
Ultrasonic output	Below 20 W/ℓ							
Ultrasonic frequency	Below 40 kHz							
Ultrasonic washing period	5 min. or less							
6. Post cleaning processes	<ol style="list-style-type: none"> 1. With some type of resins a decomposition gas or chemical reaction vapor may remain inside the resin during the hardening period or while left under normal storage conditions resulting in the deterioration of the capacitor's performance. 2. When a resin's hardening temperature is higher than the capacitor's operating temperature, the stresses generated by the excess heat may lead to capacitor damage or destruction. The use of such resins, molding materials etc. is not recommended. 							
7. Handling	<p>Breakaway PC boards (splitting along perforations)</p> <ol style="list-style-type: none"> 1. When splitting the PC board after mounting capacitors and other components, care is required so as not to give any stresses of deflection or twisting to the board. 2. Board separation should not be done manually, but by using the appropriate devices. <p>Mechanical considerations</p> <ol style="list-style-type: none"> 1. Be careful not to subject the capacitors to excessive mechanical shocks. <ol style="list-style-type: none"> (1)If ceramic capacitors are dropped onto the floor or a hard surface, they should not be used. (2)When handling the mounted boards, be careful that the mounted components do not come in contact with or bump against other boards or components. 							

Precautions on the use of Multilayer Ceramic Capacitors

Stages	Precautions	Technical considerations				
8.Storage conditions	<p>Storage</p> <p>1. To maintain the solderability of terminal electrodes and to keep the packaging material in good condition, care must be taken to control temperature and humidity in the storage area. Humidity should especially be kept as low as possible.</p> <ul style="list-style-type: none"> • Recommended conditions <table border="0" style="margin-left: 20px;"> <tr> <td>Ambient temperature</td> <td>Below 40°C</td> </tr> <tr> <td>Humidity</td> <td>Below 70% RH</td> </tr> </table> <p>The ambient temperature must be kept below 30°C. Even under ideal storage conditions capacitor electrode solderability decreases as time passes, so should be used within 6 months from the time of delivery.</p> <ul style="list-style-type: none"> • Ceramic chip capacitors should be kept where no chlorine or sulfur exists in the air. <p>2. The capacitance value of high dielectric constant capacitors (type 2 &3) will gradually decrease with the passage of time, so this should be taken into consideration in the circuit design. If such a capacitance reduction occurs, a heat treatment of 150°C for 1hour will return the capacitance to its initial level.</p>	Ambient temperature	Below 40°C	Humidity	Below 70% RH	<p>1. If the parts are stored in a high temperature and humidity environment, problems such as reduced solderability caused by oxidation of terminal electrodes and deterioration of taping/packaging materials may take place. For this reason, components should be used within 6 months from the time of delivery. If exceeding the above period, please check solderability before using the capacitors.</p>
Ambient temperature	Below 40°C					
Humidity	Below 70% RH					

高周波用円筒セラミックコンデンサ (セラチップ)

TUBULAR TYPE CERAMIC CAPACITORS (FOR HIGH FREQUENCY)

OPERATING TEMP. -25°C~+85°C

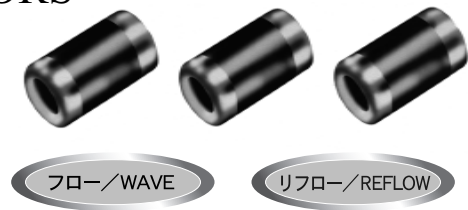

特長 FEATURES

- 高周波特性に優れる
 - インピーダンス特性が良好
 - 等価直列抵抗(ESR)が小さい
 - 高周波でのQ値が高い
 - ハンダくわれ・ぬれ性に対する端子電極対応により、ハンダ付けの信頼性に優れる
 - 耐熱衝撃性に優れる
 - 寸法安定性に優れ、高い実装性を誇る
 - 基板曲げ時の耐ベンディング性に優れる
 - チューナ特性に優れる
- Excellent high-frequency characteristics:
 - * Good impedance characteristics
 - * Low equivalent series resistance
 - * Large Q-value at high frequencies
 - Compatible with 0603 and 0805 component solder pad dimensions
 - Highly resistant to heat and impact
 - Excellent solderability and ability to withstand PCB bending
 - Excellent tuner characteristics

用途 APPLICATIONS

- 通信機器用
 - 携帯電話、PHS、コードレス電話etc
 - 民生機器用
 - チューナ、ビデオ、テレビetc
- Communications Equipment: portable telephones, PHS, other wireless applications, etc.
 - Consumer Electronic Appliances: tuners, video equipment, television sets, etc.

形名表記法 ORDERING CODE

1	2	3	4	5	6	7
定格電圧 (VDC)	分類	形状寸法(mm)	温度特性 (ppm/°C)	公称静電容量 (pF)	容量許容差	包装
B 12 (16可) E 16 T 35 U 50	CN 円筒コンデンサ	033 1.6×1.0 053 2.0×1.25	△A ±5% △B ±10% △F ±30% △W ±10% △Y ±22% C□ 0: CK, CJ, CH □許容差 R□ -220: RK, RJ, RH S□ -330: SK, SJ, SH H ±60 T□ -470: TK, TJ, TH J ±120 U□ -750: UK, UJ K ±250 SL +350~-1000 L ±500 △=スペース	例 0R5 0.5 010 1 472 4700 R=小数点	10pF以下 10pF超 C△ ±0.25 pF D△ ±0.5 pF F△ ±1 pF J△ ±5% K△ ±10% M△ ±20% N△ ±30% Z△ ±80/-20% △=スペース	△△ 単品(袋詰め) -2 テーピング -7 バルクカセット品 △=スペース

U C N 0 3 3 C H 1 0 0 D △ - 2

1 2 3 4 5 6 7

1	2	3	4	5	6	7
Rated voltage(VDC)	Type	External Dimensions(mm)	Temperature characteristics(ppm/°C)	Nominal Capacitance(pF)	Capacitance Tolerances	Packaging
B 12 (Available up to 16) E 16 T 35 U 50	CN Tubular capacitor	033 1.6×1.0 053 2.0×1.25	△A ±5% △B ±10% △F ±30% △W ±10% △Y ±22% C□ 0: CK, CJ, CH □=Tolerance R□ -220: RK, RJ, RH S□ -330: SK, SJ, SH H ±60 T□ -470: TK, TJ, TH J ±120 U□ -750: UK, UJ K ±250 SL +350~-1000 L ±500 △=Blank space	0R5 0.5 010 1 472 4700 *R=decimal point	10pF≤ 10pF> C△ ±0.25 pF D△ ±0.5 pF F△ ±1 pF J△ ±5% K△ ±10% M△ ±20% N△ ±30% Z△ ±80/-20% △=Blank space	△△ Bulk -2 Tape & reel -7 Bulk cassette △=Blank space

外形寸法 EXTERNAL DIMENSIONS

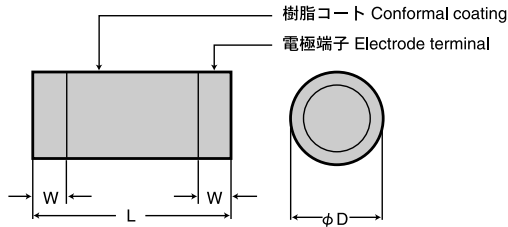

Type	L	φD	W
033	1.6 ^{+0.2} _{-0.1} (0.063 ^{+0.008} _{-0.004})	1.0±0.1 (0.039±0.004)	0.3±0.15 (0.012±0.006)
	2.0 ^{+0.2} _{-0.1} (0.079 ^{+0.008} _{-0.004})	1.25±0.2 (0.049±0.008)	0.3 ^{+0.2} _{-0.1} (0.012 ^{+0.008} _{-0.004})

Unit : mm(inch)

概略バリエーション AVAILABLE CAPACITANCE RANGE

Class1 (Temperature compensating)

WV		50V(UCN)											
Temp.char.	Type	C□		R□		S□		T□		U□		SL	
		033	053	033	053	033	053	033	053	033	053	033	053
Cap [pF]	[pF 3digits]												
0.5	0R5												
0.75	R75												
1	101												
1.5	1R5												
2	020												
2.5	2R5												
3	030												
3.5	3R5												
4	040												
4.5	4R5												
5	050												
6	060												
7	070												
8	080												
9	090												
10	100												
11	110												
12	120												
13	130												
15	150												
16	160												
18	180												
20	200												
22	220												
24	240												
27	270												
30	300												
33	330												
36	360												
39	390												
43	430												
47	470												
51	510												
56	560												
68	680												
75	750												
82	820												
91	910												
100	101												
120	121												
150	151												

Class2, 3 (High dielectric constant)

WV		50V(UCN)				35V(TCN)		16V(BCN)		16V(ECN)	
Temp.char.	Type	A		B		W		Y		F	
		053	033	053	033	053	033	053	033	053	033
Cap [pF]	[pF 3digits]										
68	680										
82	820										
100	101										
120	121										
150	151										
180	181										
220	221										
270	271										
330	331										
390	391										
470	471										
560	561										
680	681										
820	821										
1000	102										
1500	152										
2200	222										
3300	332										
4700	472										
8200	822										
10000	103										
15000	153										
22000	223										

仕様 SPECIFICATIONS

033Type

温度特性 Temp.char.	静電容量変化率 Capacitance Change	静電容量許容差 Capacitance Tolerance	Q or tanδ
CK	0±250ppm/℃	0.5~5pF C(±0.25pF)	Q 400+20·Cmin (C≤27pF)
RK	-220±250		
SK	-330±250		
TK	-470±250		
UK	-750±250		
CJ	0±120ppm/℃	6~10pF D(±0.5pF) F(±1pF)	500min (30≤C≤33pF)
RJ	-220±120		
SJ	-330±120		
TJ	-470±120		
UJ	-750±120		
CH	0±60ppm/℃	11~91pF J(±5%)	100min (51≤C≤91pF)
RH	-220±60		
SH	-330±60		
TH	-470±60		
SL	+350~-1000ppm/℃		
B	±10%	K(±10%)	tanδ 2.5%max
W	±10%	M(±20%)	
Y	±22%	N(±30%)	tanδ 7.5%max
F	+30 -85%	Z(+80 -20%)	

053Type

温度特性 Temp.char.	静電容量変化率 Capacitance Change	静電容量許容差 Capacitance Tolerance	Q or tanδ
CK	0±250ppm/℃	0.5~5pF C(±0.25pF)	Q 400+20·Cmin (C≤27pF)
RK	-220±250		
SK	-330±250		
TK	-470±250		
UK	-750±250		
CJ	0±120ppm/℃	6~10pF D(±0.5pF) F(±1pF)	1000min (30≤C≤39pF)
RJ	-220±120		
SJ	-330±120		
TJ	-470±120		
UJ	-750±120		
CH	0±60ppm/℃	11~56pF J(±5%)	500min (43≤C≤56pF)
RH	-220±60		
SH	-330±60		
TH	-470±60		
SL	+350~-1000ppm/℃		
A	±5%	K(±10%)	tanδ 1.5%max
B	±10%		
W	±10%	M(±20%)	tanδ 2.5%max
Y	±22%	N(±30%)	
F	+30 -85%	Z(+80 -20%)	tanδ 7.5%max

セレクションガイド Selection Guide

アイテム一覧 Part Numbers

特性図 Electrical Characteristics

梱包 Packaging

信頼性 Reliability Data

使用上の注意 Precautions



etc

アイテム一覧 PART NUMBERS

033Type
Class1

定格電圧 Rated Voltage (DC)	形名 Ordering code	温度特性 Temperature characteristics	公称静電容量 Capacitance [pF]	静電容量許容差 Capacitance tolerance	Q or tanδ	絶縁抵抗 Insulation resistance
50V	UCN033 △0R5 □	CK,RK SK,TK UK,SL	0.5	±0.25pF ±0.5 pF	Q _≥ 400+20・C (C:静電容量) (C:capacitance)	10000MΩmin.
	UCN033 △R75 □		0.75			
	UCN033 △010 □		1			
	UCN033 △1R5 □		1.5			
	UCN033 △020 □		2			
	UCN033 △2R5 □	CJ,RJ,SJ	2.5			
	UCN033 △030 □	TJ,UJ,SL	3			
	UCN033 △3R5 □	CH RH SH TH UJ SL	3.5			
	UCN033 △040 □		4			
	UCN033 △4R5 □		4.5			
	UCN033 △050 □		5			
	UCN033 △060 □		6			
	UCN033 △070 □		7			
	UCN033 △080 □		8			
	UCN033 △090 □		9			
	UCN033 △100 □		10			
	UCN033 △110 □		11			
	UCN033 △120 □	12				
	UCN033 △130 □	13				
	UCN033 △150 □	RH,SH,TH,UJ,SL	15			
	UCN033 △160 □	SH,TH,UJ,SL	16			
	UCN033 △180 □	18				
	UCN033 △200 □	TH,UJ,SL	20			
	UCN033 △220 □	22				
	UCN033 △240 □	UJ,SL	24			
	UCN033 △270 □	27				
	UCN033 SL300 □	SL	30			
	UCN033 SL330 □		33			
	UCN033 SL360 □		36			
	UCN033 SL390 □		39			
UCN033 SL430 □	43					
UCN033 SL470 □	47					
UCN033 SL510 □	51					
UCN033 SL560 □	56					
UCN033 SL680 □	68					
UCN033 SL750 □	75					
UCN033 SL820 □	82					
UCN033 SL910 □	91					
UCN033 SL101 □	100					

形名の△は温度特性記号、□は静電容量許容差記号が入ります。 △ Please specify the temperature characteristics and □ capacitance tolerance code.

Class2,3

定格電圧 Rated Voltage (DC)	形名 Ordering code		温度特性 Temperature characteristics	公称静電容量 Capacitance (pF)	静電容量許容差 Capacitance tolerance	Q or $\tan\delta$	絶縁抵抗 Insulation resistance
50V	UCN033 B121 <input type="checkbox"/>		B	120	$\pm 10\%$ $\pm 20\%$	$\tan\delta \leq 2.5$	10000M Ω min.
	UCN033 B151 <input type="checkbox"/>			150			
	UCN033 B181 <input type="checkbox"/>			180			
	UCN033 B221 <input type="checkbox"/>			220			
	UCN033 B271 <input type="checkbox"/>			270			
	UCN033 B331 <input type="checkbox"/>			330			
	UCN033 W391 <input type="checkbox"/>		W	390	$\pm 20\%$ $\pm 30\%$		
	UCN033 W471 <input type="checkbox"/>			470			
	UCN033 W561 <input type="checkbox"/>			560			
35V	TCN033 Y681 <input type="checkbox"/>		Y	680	$\pm 20\%$ $\pm 30\%$	1000M Ω min.	
	TCN033 Y821 <input type="checkbox"/>			820			
	TCN033 Y102 <input type="checkbox"/>			1000			
	TCN033 Y152 <input type="checkbox"/>			1500			
	TCN033 Y222 <input type="checkbox"/>			2200			
16V	BCN033 Y332 <input type="checkbox"/>			3300	$\pm 80\%$ -20%		
	BCN033 Y472 <input type="checkbox"/>			4700			
	ECN033 F103Z		F	10000			$\tan\delta \leq 7.5\%$

形名の△は温度特性記号、□は静電容量許容差記号が入ります。 △ Please specify the temperature characteristics and □ capacitance tolerance code.

アイテム一覧 PART NUMBERS

053Type
Class1

定格電圧 Rated Voltage (DC)	形名 Ordering code	温度特性 Temperature characteristics	公称静電容量 Capacitance [pF]	静電容量許容差 Capacitance tolerance	Q or tanδ	絶縁抵抗 Insulation resistance	
50V	UCN053 △0R5 □	CK,RK SK,TK UK,SL	0.5	±0.25pF ±0.5pF	Q≥400+20・C (C:静電容量) (C:capacitance)	10000MΩmin.	
	UCN053 △R75 □		0.75				
	UCN053 △010 □		1				
	UCN053 △1R5 □		1.5				
	UCN053 △020 □		2				
	UCN053 △2R5 □		CJ,RJ,SJ				2.5
	UCN053 △030 □	TJ,UJ,SL	3				
	UCN053 △3R5 □	CH RH SH TH UJ SL	3.5				±0.5pF ±1pF
	UCN053 △040 □		4				
	UCN053 △4R5 □		4.5				
	UCN053 △050 □		5				
	UCN053 △060 □		6				
	UCN053 △070 □		7				
	UCN053 △080 □		8				
	UCN053 △090 □		9				
	UCN053 △100 □		10				
	UCN053 △110 □		11				
	UCN053 △120 □		12				
	UCN053 △130 □		13				
	UCN053 △150 □	15					
	UCN053 △160 □	16					
	UCN053 △180 □	18					
	UCN053 △200 □	20					
	UCN053 △220 □	SH,TH,UJ,SL	22				
	UCN053 △240 □	TH,UJ,SL	24				
	UCN053 △270 □		27				
	UCN053 △300 □	UJ,SL	30				
	UCN053 SL330 □	SL	33	±5% ±10%	Q≥1000		
	UCN053 SL360 □		36				
	UCN053 SL390 □		39				
	UCN053 SL430 □		43				
	UCN053 SL470 □		47				
	UCN053 SL510 □		51				
UCN053 SL560 □	56						
UCN053 SL620 □	62						
UCN053 SL680 □	68						
UCN053 SL750 □	75						
UCN053 SL820 □	82						
UCN053 SL910 □	91						
UCN053 SL101 □	100						
UCN053 SL121 □	120						
UCN053 SL151 □	150						
				Q≥500			
				Q≥100			

形名の△は温度特性記号、□は静電容量許容差記号が入ります。

△ Please specify the temperature characteristics and □ capacitance tolerance code.

Class2、3

定格電圧 Rated Voltage (DC)	形名 Ordering code	温度特性 Temperature characteristics	公称静電容量 Capacitance (pF)	静電容量許容差 Capacitance tolerance	Q or tanδ	絶縁抵抗 Insulation resistance
50V	UCN053 A680 <input type="checkbox"/>	A	68	±10% ±20%	tanδ≤1.5%	10000MΩmin.
	UCN053 A820 <input type="checkbox"/>		82			
	UCN053 A101 <input type="checkbox"/>		100			
	UCN053 A121 <input type="checkbox"/>		120			
	UCN053 A151 <input type="checkbox"/>		150			
	UCN053 A181 <input type="checkbox"/>		180			
	UCN053 B221 <input type="checkbox"/>	B	220	±10% ±20%	tanδ≤1.5%	
	UCN053 B271 <input type="checkbox"/>		270			
	UCN053 B331 <input type="checkbox"/>		330			
	UCN053 B391 <input type="checkbox"/>		390			
	UCN053 B471 <input type="checkbox"/>		470			
	UCN053 W561 <input type="checkbox"/>	W	560	±20% ±30%	tanδ≤2.5%	
	UCN053 W681 <input type="checkbox"/>		680			
UCN053 W821 <input type="checkbox"/>	820					
35V	TCN053 Y681 <input type="checkbox"/>	Y	680	±20% ±30%	tanδ≤2.5%	1000MΩmin.
	TCN053 Y821 <input type="checkbox"/>		820			
	TCN053 Y102 <input type="checkbox"/>		1000			
	TCN053 Y152 <input type="checkbox"/>		1500			
	TCN053 Y222 <input type="checkbox"/>		2200			
16V	BCN053 Y332 <input type="checkbox"/>	Y	3300	±20% ±30%	tanδ≤2.5%	
	BCN053 Y472 <input type="checkbox"/>		4700			
	BCN053 Y682 <input type="checkbox"/>		6800			
	BCN053 Y822 <input type="checkbox"/>		8200			
	ECN053 F103 <input type="checkbox"/>	F	10000	+80% -20%	tanδ≤7.5%	
	ECN053 F153 <input type="checkbox"/>		15000			
	ECN053 F223 <input type="checkbox"/>		22000			

形名の□は静電容量許容差記号が入ります。

Please specify the capacitance tolerance code.

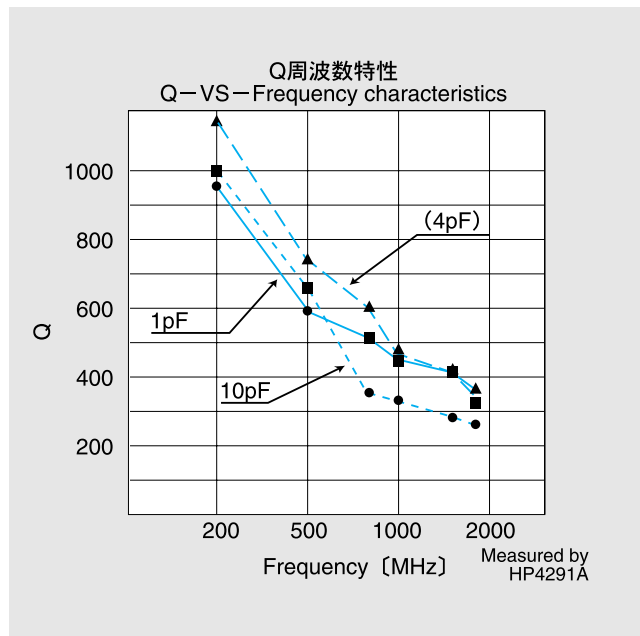
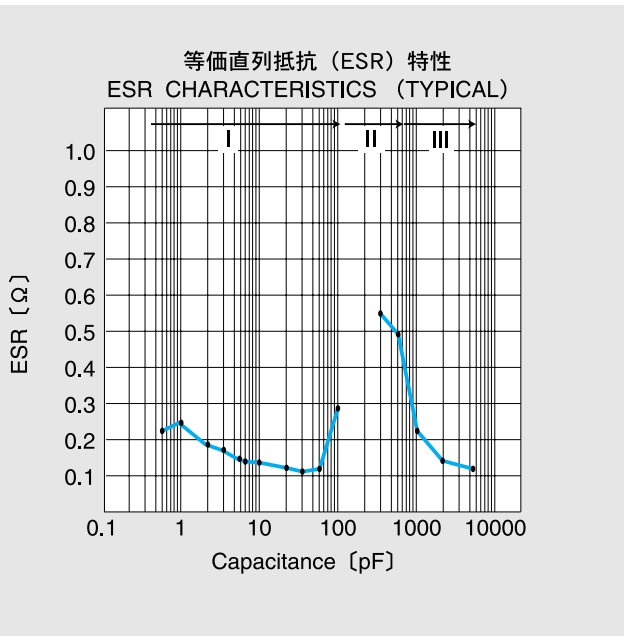

①最小受注単位数 Minimum Quantity

形式 Type	最小受注単位数(PCS) Minimum Quantity		
	袋づめ Bulk	バルクカセット Bulk cassette	テーピング Tape&Reel
033	5000	10000	3000
053	2000	6000	3000

②テーピング材質 Tape Material

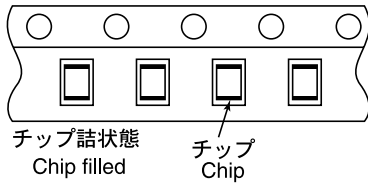
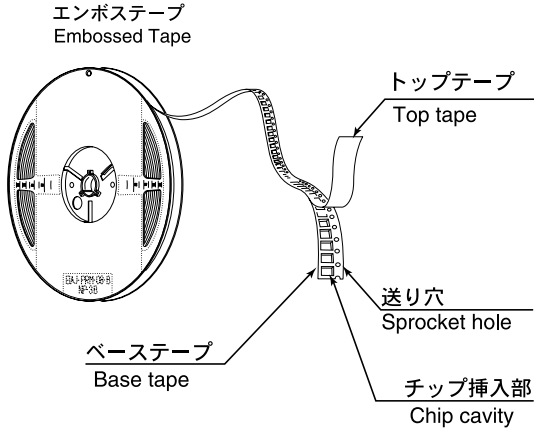

③テーピング寸法 Taping Dimensions

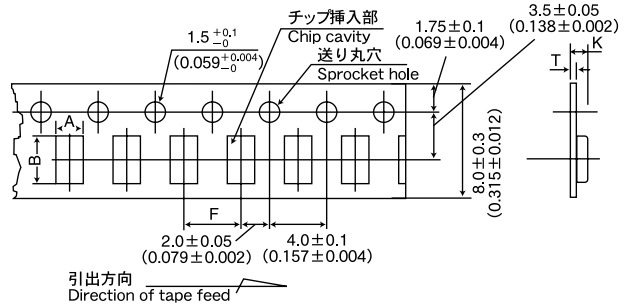

形式 Type	チップ挿入部 Chip cavity		挿入ピッチ Insertion Pitch	テープ厚み Tape Thickness	
	A	B	F	K	T
033	1.4 ± 0.1 (0.055 ± 0.004)	1.9 ± 0.2 (0.075 ± 0.008)	4.0 ± 0.1 (0.157 ± 0.004)	1.4max. (0.055max)	0.30max. (0.012max)
053	1.45 ± 0.1 (0.057 ± 0.004)	2.35 ± 0.2 (0.093 ± 0.008)	4.0 ± 0.1 (0.157 ± 0.004)	2.0max. (0.079max)	0.30max. (0.012max)

Unit : mm (inch)

④リーダー部/空部 Leader and Blank Portion

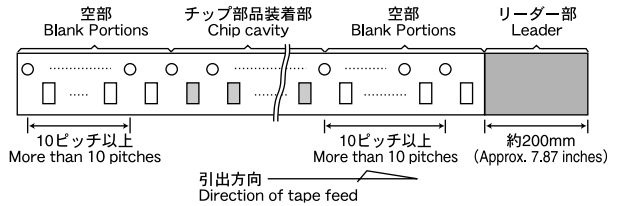

⑤リール寸法 Reel Size

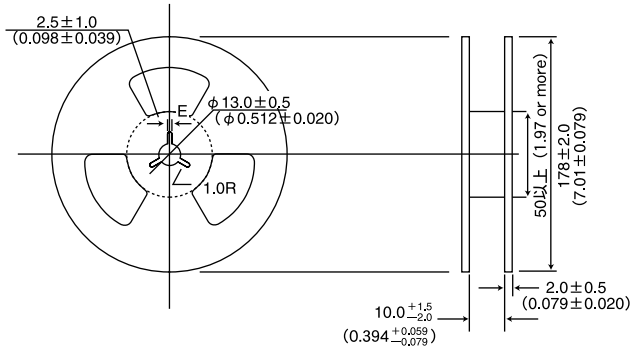

Unit = mm (inch)

⑥ トップテープ強度 Top Tape Strength

トップテープの剥離力は、下図矢印方向にて0.2~0.8Nとなります。
 The top tape requires a peel-off force of 0.2 to 0.8N in the direction of the arrow as illustrated below.

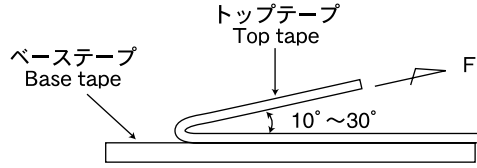

⑦ バルクカセット Bulk Cassette

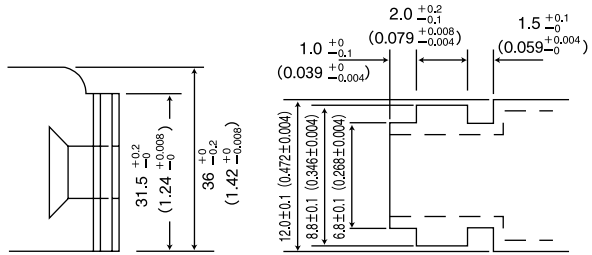
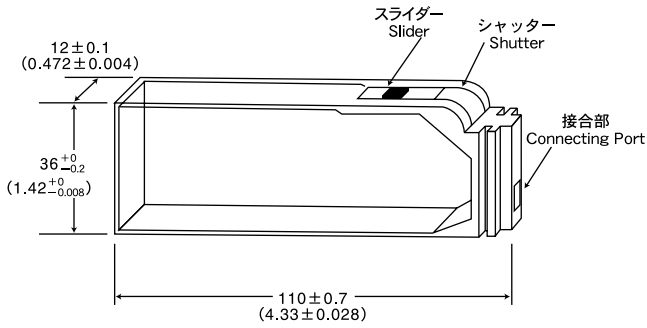

Unit : mm (inch)

TUBULAR TYPE CERAMIC CAPACITORS

Item		Specified Value			Test Methods and Remarks
		Temperature Compensating (Class 1)	High Permittivity (Class 2)	Semiconductor (Class 3)	
		Tubular(*CN)	Tubular(*CN)	Tubular(*CN)	
1. Operating Temperature Range		-25 to +85°C	-25 to +85°C	-25 to +85°C	
2. Storage Temperature Range		-25 to +85°C	-25 to +85°C	-25 to +85°C	
3. Rated Voltage		50VDC	50VDC	50 VDC, 35 VDC, 16 VDC	
4. Withstanding Voltage	Between terminals	No abnormality	No abnormality	No abnormality	Tubular (*CN): Applied voltage: Rated voltage×3 (Class 1) Rated voltage×2.5 (Class 2) Rated voltage×2 (Class 3) Duration: 1 to 5 sec. Charge/discharge current: 50mA max. (Class 1,2) 10mA max. (Class 3)
5. Insulation Resistance		10000 MΩ min	10000 MΩ min	1000 MΩ min	Applied voltage: Rated voltage Duration: 60±5 sec. Charge/discharge current: 10mA max. (Class 3)
6. Capacitance		0.5 to 5 pF : ±0.25 pF ±0.5 pF 6 to 10 pF : ±0.5 pF ±1 pF 11 pF or over : ± 5% ±10%	±10% ±20%	±20%, ±30% +80% -20%	Tubular (*CN): Measuring frequency: 1MHz ±20%(Class 1) 1kHz ±20%(Class 2,3) Measuring voltage: 1 ±0.5Vrms (Class1,2,3) 0.1Vrms max (Class3:F) Bias application: None
7. Q or Tangent of Loss Angle (tan δ)		053: Under 30 pF : Q≥400 + 20C 30 pF or over : Q≥1000 SL, 43 pF or over : Q≥500 033: Under 30 pF : Q≥400 + 20C SL, 30 to 39 pF : Q≥500 SL, 43 to 100 pF : Q≥100 C= Nominal capacitance	A: 1.5% max. B: 2.5% max.	W,Y: 2.5% max.	Tubular (*CN): Measuring frequency: 1MHz±20% (Class 1) 1kHz±20% (Class 2,3) Measuring voltage: 1 ±0.5Vrms (Class1,2,3) 0.1Vrms max (Class3:F) Bias application: None

Withstanding voltage is also referred to as "voltage proof" under IEC specifications.

TUBULAR TYPE CERAMIC CAPACITORS

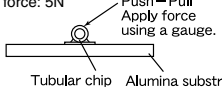
Item		Specified Value			Test Methods and Remarks
		Temperature Compensating (Class 1)	High Permittivity (Class 2)	Semiconductor (Class 3)	
		Tubular(*CN)	Tubular(*CN)	Tubular(*CN)	
8.Capacitance Change due to Temperature or Rate of Capacitance Change	(When voltage is not applied)	CK : 0±250	A : ±5%	W : ±10%	According to JIS C 5102 clause 7.12. Temperature compensating: Measurement of capacitance at 20°C and 85°C shall be made to calculate temperature characteristic by the following equation. $\frac{(C_{85}-C_{20})}{C_{20} \times \Delta T} \times 10^6 \text{ (ppm/}^\circ\text{C)}$ $\frac{(C_{-25}-C_{20})}{C_{20} \times \Delta T} \times 10^6 \text{ (ppm/}^\circ\text{C)}$ High permittivity and semiconductor types: Change of maximum capacitance deviation in step 1 to 5 Temperature at step 1: +20°C Temperature at step 2: -25°C Temperature at step 3: +20°C (Reference temperature) Temperature at step 4: +85°C Temperature at step 5: +20°C
		CJ : 0±120 CH : 0±60 RK : -220±250 RJ : -220±120 RH : -220±60 SK : -330±250 SJ : -330±120 SH : -330±60 TK : -470±250 TJ : -470±120 TH : -470±60 UK : -750±250 UJ : -750±120 SL : +350 to -1000 (ppm/°C)	B : ±10%	Y : ±22%	
9.Adhesion of Electrode	No damage	No damage	No damage	Tubular (*CN): Applied force: 5N  Tubular chip Alumina substrate (t = 1.0mm)	
10.Solderability	At least 80% of terminal electrodes is covered by new solder.	At least 80% of terminal electrodes is covered by new solder.	At least 80% of terminal electrodes is covered by new solder.	Tubular (*CN): According to JIS C 5102 clause 8.13. Solder temperature: 230±5°C Duration: 4±1 sec.	

TUBULAR TYPE CERAMIC CAPACITORS

Item	Specified Value			Test Methods and Remarks
	Temperature Compensating (Class 1)	High Permittivity (Class 2)	Semiconductor (Class 3)	
	Tubular(*CN)	Tubular(*CN)	Tubular(*CN)	
11. Resistance to Soldering Heat	Appearance: No abnormality Capacitance change: Within $\pm 2.5\%$ or $\pm 0.25\text{pF}$, whichever is larger. Q: Initial value Insulation resistance: Initial value Withstanding voltage (between terminals): No abnormality	Appearance: No abnormality Capacitance change: A: Within $\pm 3\%$ B: Within $\pm 5\%$ $\tan \delta$: Initial value Insulation resistance: Initial value Withstanding voltage (between terminals): No abnormality	Appearance: No abnormality Capacitance change: A: Within $\pm 7.5\%$ (B, BJ) B: Within $\pm 20\%$ (F) $\tan \delta$: Initial value Insulation resistance: Initial value Withstanding voltage (between terminals): No abnormality	Tubular (*CN): According to JIS C 5102 clause 8.14. Solder temperature: $270 \pm 5^\circ\text{C}$ Duration: 3 ± 0.5 sec. Preheating conditions: 80 to 120°C , 2 min. 150 to 200°C , 2 min. Recovery: Recovery for the following period under the standard condition after the test. 24 \pm 2 hrs (Class 1) 48 \pm 4 hrs (Class 2,3) * The Class 3 requires thermal treatment after the test.
12. Thermal Shock	Appearance: No abnormality Capacitance change: Within $\pm 2.5\%$ or $\pm 0.25\text{pF}$, whichever is larger. Q: Initial value 0.5~27pF $Q \geq 400 + 20\text{C}$ SL 30~39pF $Q \geq 500$ 43~100pF $Q \geq 100$ Insulation resistance: Initial value Withstanding voltage (between terminals): No abnormality	Appearance: No abnormality Capacitance change: A: Within $\pm 3\%$ B: Within $\pm 5\%$ $\tan \delta$: Initial value Insulation resistance: Initial value Withstanding voltage (between terminals): No abnormality	Appearance: No abnormality Capacitance change: Within $\pm 5\%$ $\tan \delta$: 3% max. Insulation resistance: Initial value Withstanding voltage (between terminals): No abnormality	Tubular (*CN): Conditions for 1 cycle: Step 1: Room temperature 10 min. Step 2: $-25 \pm 3^\circ\text{C}$ 30 min. Step 3: Room temperature 10 min. Step 4: $+85 \pm 3^\circ\text{C}$ 30 min. Number of cycles: 5 Recovery: Recovery for the following period under the standard condition after the test. 24 \pm 2 hrs (Class 1) 48 \pm 4 hrs (Class 2,3)

Withstanding voltage is also referred to as "voltage proof" under IEC specifications.

Thermal Shock is also referred to as "rapid change of temperature" under IEC specifications.

TUBULAR TYPE CERAMIC CAPACITORS

Item	Specified Value			Test Methods and Remarks
	Temperature Compensating (Class 1)	High Permittivity (Class 2)	Semiconductor (Class 3)	
	Tubular(*CN)	Tubular(*CN)	Tubular(*CN)	
13.Damp Heat (steady state)	Appearance : No abnormality Capacitance change: Within $\pm 5\%$ or $\pm 0.5\text{pF}$, whichever is larger. Q(033): 0.5 to 9 pF : $Q \geq 200 + 10C$ 10 to 27 pF : $Q \geq 275 + 2.5C$ 30 to 39 pF : $Q \geq 250(\text{SL})$ 43 to 100 pF : $Q \geq 50(\text{SL})$ Q(053): $C \geq 30$ pF : $Q \geq 350$ $10 \leq C < 30$ pF : $Q \geq 275 + 2.5C$ $C < 10$ pF : $Q \geq 200 + 10C$ 053SL43 pF or over : $Q \geq 250$ C= Nominal capacitance Insulation resistance : 1000 M Ω min.	Appearance : No abnormality Capacitance change: A: Within $\pm 7.5\%$ B: Within $\pm 10\%$ tan δ : A : 3% max. B : 5% max. Insulation resistance: 1000 M Ω min.	Appearance : No abnormality Capacitance change: Within $\begin{matrix} +10 \\ -15 \end{matrix} \%$ tan δ : 5% max. Insulation resistance : 500 M Ω min. (033) 1000M Ω min (053)	Tubular (*CN033,053): Temperature: $40 \pm 2^\circ\text{C}$ Humidity: 90 to 95% RH Duration: $500 \begin{matrix} +24 \\ -0 \end{matrix}$ hrs Recovery: Recovery for the following period under the standard condition after the removal from test chamber. 24 \pm 2 hrs (Class 1) 48 \pm 4 hrs (Class 2,3)
14.Loading under Damp Heat	Appearance: No abnormality Capacitance change: Within $\pm 7.5\%$ or $\pm 0.75\text{pF}$, whichever is larger. Q(033): 0.5 to 27 pF : $Q \geq 100 + 10C/3$ 30 to 39 pF : $Q \geq 250(\text{SL})$ 43 to 100 pF : $Q \geq 30(\text{SL})$ Q(053): $C \geq 30$ pF : $Q \geq 200$ $C < 30$ pF : $Q \geq 100 + 10C/3$ 053SL43 pF or over: $Q \geq 150$ C= Nominal capacitance Insulation resistance: 500 M Ω min.	Appearance: No abnormality Capacitance change: A : Within $\pm 7.5\%$ B : Within $\pm 10\%$ tan δ : A : 5% max. B : 5% max. Insulation resistance: 500 M Ω min.	Appearance: No abnormality Capacitance change: Within $\begin{matrix} +10 \\ -15 \end{matrix} \%$ tan δ : 5% max. Insulation resistance: 250 M Ω min.	According to JIS C 5102 clause 9.9. Tubular (*CN): Temperature: $40 \pm 2^\circ\text{C}$ Humidity: 90 to 95% RH Duration: $500 \begin{matrix} +24 \\ -0 \end{matrix}$ hrs (*CN033,053) Applied voltage: Rated voltage Charge and discharge current: 50mA max. (Class 1,2) 10mA max. (Class 3) Recovery: Recovery for the following period under the standard condition after the removal from test chamber. As for Class 3, thermal treatment shall be performed prior to the recovery. 24 \pm 2 hrs (Class 1) 48 \pm 4 hrs (Class 2,3)

Withstanding voltage is also referred to as "voltage proof" under IEC specifications.

TUBULAR TYPE CERAMIC CAPACITORS

Item	Specified Value			Test Methods and Remarks
	Temperature Compensating (Class 1)	High Permittivity (Class 2)	Semiconductor (Class 3)	
	Tubular(*CN)	Tubular(*CN)	Tubular(*CN)	
15. Load Test under High Temp	Appearance: No abnormality Capacitance change: Within $\pm 3\%$ or $\pm 0.3\text{pF}$, whichever is larger. Q(033): 0.5 to 9 pF : $Q \geq 200 + 10C$ 10 to 27 pF : $Q \geq 275 + 2.5C$ 30 to 39 pF : $Q \geq 250(\text{SL})$ 43 to 100 pF : $Q \geq 50(\text{SL})$ Q(053): $C \geq 30$ pF : $Q \geq 350$ $10 \leq C < 30$ pF : $Q \geq 275 + 2.5C$ $C < 10$ pF : $Q \geq 200 + 10C$ 053SL43 pF or over : $Q \geq 250$ C= Nominal capacitance Insulation resistance: 1000 M Ω min.	Appearance: No abnormality Capacitance change: A: Within $\pm 7.5\%$ B: Within $\pm 10\%$ tan δ : A : 3% max. B : 4% max. Insulation resistance: 1000 M Ω min.	Appearance: No abnormality Capacitance change: Within $^{+10}_{-15}\%$ tan δ : 5% max. Insulation resistance: 500 M Ω min.	According to JIS C 5102 clause 9.10. Tubular (*CN): Temperature: $85 \pm 2^\circ\text{C}$ Duration: 1000^{+48}_0 hrs (*CN033,053) Applied voltage: Rated voltage $\times 2$ (Class 1,2) Rated voltage $\times 1.25$ (Class 3) Charge and discharge current: 50mA max. (Class 1,2) 10mA max. (Class 3) Recovery: Recovery for the following period under the standard condition after the removal from test chamber. As for Class 3, thermal treatment shall be performed prior to the recovery. 24 ± 2 hrs (Class 1) 48 ± 4 hrs (Class 2,3)

Note 1: Thermal treatment (Tubular/*CN Class3): 1 hr of thermal treatment at $120 \pm 3^\circ\text{C}$ followed by 4 hrs of recovery under the standard condition shall be performed before the measurement.

Note on standard condition: "standard condition" referred to herein is defined as follows:

5 to 35°C of temperature, 45 to 85% relative humidity and 86 to 106kPa of air pressure.

When there are questions concerning measurement results:

In order to provide correlation data, the test shall be conducted under condition of $20 \pm 2^\circ\text{C}$ of temperature, 60 to 70% relative humidity and 86 to 106kPa of air pressure.

Unless otherwise specified, all the tests are conducted under the "standard condition."







*Please specify the rated voltage code.

Withstanding voltage is also referred to as "voltage proof" under IEC specifications.

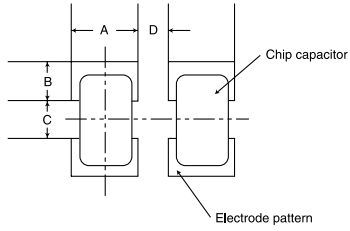
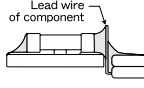
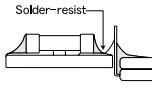
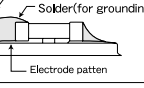
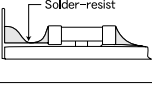
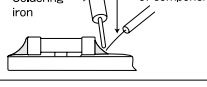
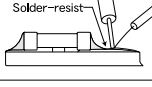
Precautions on the use of Tubular Type

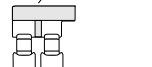
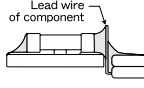
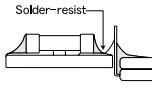
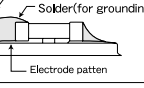
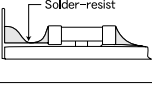
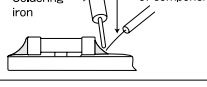
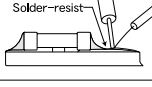
Stages	Precautions	Technical considerations
<p>1. Circuit Design</p>	<p>◆Verification of operating environment, electrical rating and performance</p> <p>1. A malfunction in medical equipment, spacecraft, nuclear reactors, etc. may cause serious harm to human life or have severe social ramifications. As such, any capacitors to be used in such equipment may require higher safety and/or reliability considerations and should be clearly differentiated from components used in general purpose applications.</p> <p>◆Operating Voltage (Verification of Rated voltage)</p> <p>1. The operating voltage for capacitors must always be lower than their rated values.</p> <p>If an AC voltage is loaded on a DC voltage, the sum of the two peak voltages should be lower than the rated value of the capacitor chosen. For a circuit where both an AC and a pulse voltage may be present, the sum of their peak voltages should also be lower than the capacitor's rated voltage.</p> <p>2. Even if the applied voltage is lower than the rated value, the reliability of capacitors might be reduced if either a high frequency AC voltage or a pulse voltage having rapid rise time is present in the circuit.</p> <p>◆Operating Current (Limitation in the current)</p> <p>1. General purpose capacitors are usually designed in a DC environment. Therefore, if capacitors are used in the circuits where AC or Pulse voltages are loaded, a large current running through the capacitor may result in a short-circuit due to self-generated heat.</p> <p>2. Class 3 capacitors have limitations in charging and discharging current. Therefore, if the current is overloaded it may cause the capacitor to short-circuit, burn or smoke.</p> <p>◆Operating Environment precautions</p> <p>1. Capacitors should not be used in the following environments:</p> <p>(1)Environmental conditions to avoid</p> <ul style="list-style-type: none"> a. exposure to water or salt water. b. exposure to moisture or condensation. c. exposure to corrosive gases (such as hydrogen sulfide, sulfurous acid, chlorine, and ammonia) 	

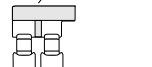
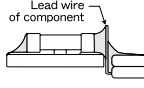
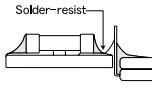
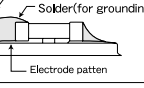
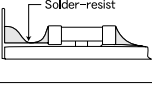
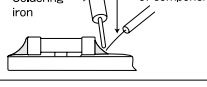
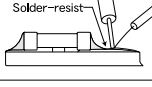
Precautions on the use of Tubular Type

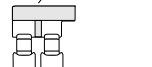
Stages	Precautions	Technical considerations																																													
<p>2. PCB Design</p>	<p>◆Pattern configurations (Design of Land-patterns)</p> <p>1. When capacitors are mounted on a PCB, the amount of solder used (size of fillet) can directly affect capacitor performance. Therefore, the following items must be carefully considered in the design of solder land patterns:</p> <p>(1) The amount of solder applied can affect the ability of chips to withstand mechanical stresses which may lead to breaking or cracking. Therefore, when designing land-patterns it is necessary to consider the appropriate size and configuration of the solder pads which in turn determines the amount of solder necessary to form the fillets.</p> <p>(2) When more than one part is jointly soldered onto the same land or pad, the pad must be designed so that each component's soldering point is separated by solder-resist.</p>	<p>1. The following diagrams and tables show some examples of recommended patterns to prevent excessive solder amounts (larger fillets which extend above the component end terminations). Examples of improper pattern designs are also shown.</p> <p>(1) Recommended land dimensions for a typical chip capacitor Electrode patterns for PCBs</p>  <p>Recommended land patterns for wave soldering Unit: (mm)</p> <table border="1" data-bbox="853 753 1212 934"> <thead> <tr> <th>Type</th> <th>053</th> <th>033</th> </tr> </thead> <tbody> <tr> <td>Location A</td> <td>1.2</td> <td>1.0</td> </tr> <tr> <td>Location B</td> <td>1.2</td> <td>1.0</td> </tr> <tr> <td>Location C</td> <td>1.1</td> <td>0.8~1.0</td> </tr> <tr> <td>Location D</td> <td>1.0</td> <td>0.8</td> </tr> </tbody> </table> <p>Recommended land patterns for reflow soldering Unit: (mm)</p> <table border="1" data-bbox="853 982 1212 1164"> <thead> <tr> <th>Type</th> <th>053</th> <th>033</th> </tr> </thead> <tbody> <tr> <td>Location A</td> <td>1.2</td> <td>0.9</td> </tr> <tr> <td>Location B</td> <td>0.8</td> <td>0.6</td> </tr> <tr> <td>Location C</td> <td>1.0</td> <td>0.9</td> </tr> <tr> <td>Location D</td> <td>0.5 or more</td> <td>0.5 or more</td> </tr> </tbody> </table> <p>Notes;</p> <ol style="list-style-type: none"> When designing land patterns, rounded corners on the solder pad might result in better solderability. The size of the solder pad can vary depending on the part location and amount of solder. Therefore, please carefully consider location and solder amounts when designing solder pads. <p>• Examples of good and bad solder application</p> <table border="1" data-bbox="853 1452 1452 1900"> <thead> <tr> <th>Item</th> <th>Not recommended</th> <th>Lead wire of component</th> </tr> </thead> <tbody> <tr> <td>Mixe-mounting of SMD and leaded components</td> <td></td> <td></td> </tr> <tr> <td>Component placement close to the chassis</td> <td></td> <td></td> </tr> <tr> <td>Hand-soldering of leaded components near mounted components</td> <td></td> <td></td> </tr> <tr> <td>Horizontal component placement</td> <td></td> <td></td> </tr> </tbody> </table>	Type	053	033	Location A	1.2	1.0	Location B	1.2	1.0	Location C	1.1	0.8~1.0	Location D	1.0	0.8	Type	053	033	Location A	1.2	0.9	Location B	0.8	0.6	Location C	1.0	0.9	Location D	0.5 or more	0.5 or more	Item	Not recommended	Lead wire of component	Mixe-mounting of SMD and leaded components			Component placement close to the chassis			Hand-soldering of leaded components near mounted components			Horizontal component placement		
Type	053	033																																													
Location A	1.2	1.0																																													
Location B	1.2	1.0																																													
Location C	1.1	0.8~1.0																																													
Location D	1.0	0.8																																													
Type	053	033																																													
Location A	1.2	0.9																																													
Location B	0.8	0.6																																													
Location C	1.0	0.9																																													
Location D	0.5 or more	0.5 or more																																													
Item	Not recommended	Lead wire of component																																													
Mixe-mounting of SMD and leaded components																																															
Component placement close to the chassis																																															
Hand-soldering of leaded components near mounted components																																															
Horizontal component placement																																															

Precautions on the use of Tubular Type

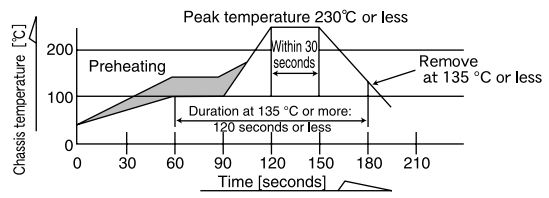
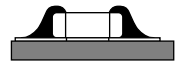
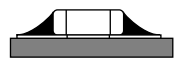
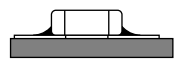
Stages	Precautions	Technical considerations
4. Soldering	<p>◆Selection of Flux</p> <ol style="list-style-type: none"> When soldering capacitors on the board, flux should be applied thinly and evenly. Flux used should be with less than or equal to 0.1 wt% (equivalent to Chlorine) of halogenated content. Flux having a strong acidity content should not be applied. When using water-soluble flux, special care should be taken to properly clean the boards. <p>◆Wave Soldering</p> <p>Temperature, time, amount of solder, etc. are specified in accordance with the following recommended conditions.</p> <p>◆Reflow Soldering</p> <ol style="list-style-type: none"> Temperature, time, amount of solder, etc. are specified in accordance with the following recommended conditions. The time between solder paste application and capacitor placement should be as short as possible The selection of appropriate solder materials is required. 	<ol style="list-style-type: none"> Flux is used to increase solderability in wave soldering, but if too much is applied, a large amount of flux gas may be emitted and may detrimentally affect solderability. To minimize the amount of flux applied, it is recommended to use a flux-bubbling system. With too much halogenated substance (Chlorine, etc.) content is used to activate the flux, an excessive amount of residue after soldering may lead to corrosion of the terminal electrodes or degradation of insulation resistance on the surface of the capacitors. Since the residue of water-soluble flux is easily dissolved by water content in the air, the residue on the surface of capacitors in high humidity conditions may cause a degradation of insulation resistance and therefore affect the reliability of the components. The cleaning methods and the capability of the machines used should also be considered carefully when selecting water-soluble flux. <p>1-1. If capacitors are used beyond the range of the following recommended conditions, heat stresses may cause cracks inside the capacitors, and consequently degrade the reliability of the capacitors. Above all, rapid heating/cooling or partial heating tend to be the major causes of cracks.</p> <p>[Examples of reflow soldering]</p>  <ol style="list-style-type: none"> Excessively long soldering times or high soldering temperatures may cause separation of the terminations from chip bodies, or leakage of capacity. If solder paste is left exposed for a long period of time before capacitors are placed the surface dries out and a membrane film will form on the board surface causing a considerable reduction in solderability. During the reflow process, when too much solder paste is applied excess solder mass can produce mechanical and heat stresses on the capacitors and may consequently result in the breakage or cracking of the components. On the other hand, too little solder paste will weaken the adhesion characteristics and may consequently cause separation of components and degrade the circuit reliability. <div style="display: flex; justify-content: space-around; align-items: flex-end;"> <div style="text-align: center;"> <p>(a) Too much solder</p>  </div> <div style="text-align: center;"> <p>(b) Appropriate amount of solder</p>  </div> <div style="text-align: center;"> <p>(c) Too little solder</p>  </div> </div> <ol style="list-style-type: none"> With inappropriate solder materials, solder balls may form. These solder balls must be thoroughly removed, since the balls would cause a reduction in capacitor electrical characteristics or degradation of reliability.

Precautions on the use of Tubular Type

Stages	Precautions	Technical considerations						
<p>4. Soldering</p>	<p>◆Hand soldering with iron</p> <ol style="list-style-type: none"> Temperature, time, amount of solder, etc. are specified in accordance with the following recommended conditions. When touch-up work is required for repair, preheating must be conducted with appropriate temperature control. Special attention should be paid to the diameter of the soldering iron tip and wattage when additional part mounting or repair work takes place. The solder iron should only directly touch the external electrodes. Amount of solder should be applied at the appropriate level. 	<ol style="list-style-type: none"> If capacitors are used beyond the range of the following recommended conditions, heat stresses may cause cracks inside the capacitors, and consequently degrade the reliability of the capacitors. Above all, rapid heating/cooling or partial heating tend to be the major causes of cracks. Recommended conditions for solder iron touch-up <p>[Example of soldering iron]</p> <table border="1" data-bbox="847 417 1453 497"> <thead> <tr> <th>Soldering iron's temperature [°C]</th> <th>Watt [W]</th> <th>Iron tip dia. [mm]</th> </tr> </thead> <tbody> <tr> <td>Below 270</td> <td>Below 20</td> <td>Below 3.0 in diameter</td> </tr> </tbody> </table> <p>Temperature range between iron tip and preheating temperature. 130°C or less Duration 3 seconds or less Number of times 3 times or less</p> <ol style="list-style-type: none"> Selection of soldering irons Temperature at the tip of the soldering iron varies depending on the type of soldering iron. If the temperature at the tip of the soldering iron is too high thermal stresses may cause cracks in the component. If the soldering iron tip touches the ceramic material directly, the component may develop heat stresses, and cracks. During the solder iron process, when too much solder is used it can result in mechanical and heat stresses on the capacitors and may consequently result in the breakage or cracking of the components. On the other hand, too little solder will weaken the adhesion characteristics and may consequently cause separation of components and degrade the circuit reliability. <p>(Appropriate application of soldering iron) (Appropriate amount of solder)</p> 	Soldering iron's temperature [°C]	Watt [W]	Iron tip dia. [mm]	Below 270	Below 20	Below 3.0 in diameter
Soldering iron's temperature [°C]	Watt [W]	Iron tip dia. [mm]						
Below 270	Below 20	Below 3.0 in diameter						
<p>5. Cleaning</p>	<p>◆Board cleaning</p> <ol style="list-style-type: none"> When using ultrasonic cleaning on PC boards with capacitors, avoid subjecting the PCB directly to vibration. Special attention should be paid to output frequency and duration of ultrasonic cleaning. Cleaning conditions should be determined after verifying, through a test run, that the cleaning process does not affect the capacitor's characteristics. 	<ol style="list-style-type: none"> In the case of ultrasonic cleaning, too much power output can cause excessive vibration of the PC board which may lead to the cracking of the capacitor or the soldered portion, or decrease the terminal electrodes' strength. Thus the following conditions should be carefully checked; <table border="1" data-bbox="884 1203 1206 1284"> <tbody> <tr> <td>Ultrasonic output</td> <td>Below 20 W/l</td> </tr> <tr> <td>Ultrasonic frequency</td> <td>Below 40 kHz</td> </tr> <tr> <td>Ultrasonic cleaning period</td> <td>5 min. or less</td> </tr> </tbody> </table> In case of insufficient cleaning <ol style="list-style-type: none"> The halogenated content in the flux residue may lead to corrosion of the terminal electrodes or degradation of insulation resistance. When using water-soluble flux, it may degrade insulation resistance characteristics of the capacitor surface. 	Ultrasonic output	Below 20 W/l	Ultrasonic frequency	Below 40 kHz	Ultrasonic cleaning period	5 min. or less
Ultrasonic output	Below 20 W/l							
Ultrasonic frequency	Below 40 kHz							
Ultrasonic cleaning period	5 min. or less							
<p>6. Post cleaning processes</p>	<p>◆Application of resin molding, etc. to the PCB and components.</p> <ol style="list-style-type: none"> Please contact your local Taiyo Yuden sales office before performing resin coating or molding on mounted capacitors. 	<ol style="list-style-type: none"> 1-1. When a resin's hardening temperature is higher than the capacitor's operating temperature, the stresses generated by the excess heat may lead to capacitor damage or destruction. 1-2. With some type of resins a decomposition gas or chemical reaction vapor may remain inside the resin during the hardening period or while left under normal storage conditions resulting in the deterioration of the capacitor's performance. 1-3. Some types of coating or molding material may degrade humidity resistance. Therefore, it is highly recommended you contact the material manufacturer before using. 						

Precautions on the use of Tubular Type

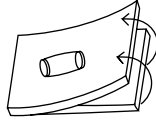
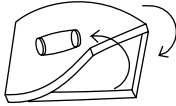
Stages	Precautions	Technical considerations
7. Handling	<p>◆Breakaway PC boards (splitting along perforations)</p> <ol style="list-style-type: none"> When splitting the PC board after mounting capacitors and other components, care is required so as not to give any stresses of deflection or twisting to the board. Board separation should not be done manually, but by using the appropriate devices. <p>◆Mechanical considerations</p> <ol style="list-style-type: none"> Be careful not to subject the capacitors to excessive mechanical shocks. If ceramic capacitors are dropped on the floor or a hard surface they should not be used. 	<p>1. If the board is subjected to the stresses of deflection and twisting (as shown below) when splitting or breaking away the boards, it may cause cracks in the board.</p> <div style="display: flex; justify-content: space-around; align-items: center;"> <div style="text-align: center;"> <p>Deflection</p>  </div> <div style="text-align: center;"> <p>Twisting</p>  </div> </div> <ol style="list-style-type: none"> Because the capacitor is made of ceramic, mechanical shocks applied to the board may damage or crack the capacitors. Ceramic capacitors which are dropped onto the floor or a hard surface may develop defects and have a higher risk of failure over time.
8. Storage conditions	<p>◆Storage</p> <ol style="list-style-type: none"> To maintain the solderability of terminal electrodes and to keep the packaging material in good condition, care must be taken to control temperature and humidity in the storage area. Humidity should especially be kept as low as possible. Recommended conditions: Ambient temperature Below 40 deg °C Humidity Below 70% RH Capacitors should not be kept in an environment filled with decomposition gases such as (sulfurous hydrogen, sulfuric acid, chlorine, ammonia, etc.) Capacitors should not be kept in a location where they may be exposed to moisture, condensation or direct sunlight. 	<ol style="list-style-type: none"> Under high temperature/high humidity conditions, the decrease in solderability due to the oxidation of terminal electrodes and deterioration of taping and packaging characteristics may be accelerated, so the products should be used within 6 months after delivery. After the above period, the solderability should be checked before using the capacitors. Harmful gasses in the ambient air may also degrade the solderability of the terminal electrodes resulting in a deterioration of the capacitor's reliability. Direct sunlight, the photochemical effect of resin coatings, or a rapid change in the humidity may cause condensation on or around the terminals. So special care must be taken to prevent reduced solderability or performance of the capacitors.

アキシャルリード形セラミックコンデンサ

AXIAL LEADED CERAMIC CAPACITORS

OPERATING TEMP. -25~+85°C



フロー/WAVE

特長 FEATURES

- 汎用型セラミックコンデンサで、単層形と積層形合わせて1pF~1μFと広い容量範囲で部品の標準化が可能
- ラジアルに比べ自挿コストが安く、部品高さ低減、実装密度アップ、在庫スペースも減少
- This widely used ceramic capacitor includes both monolithic and multilayer types to provide a wide capacitance range of 1pF through 1uF in one standard size and shape.
- Automatic insertion related costs are lower than with radial type capacitors.

用途 APPLICATIONS

- Class1品は回路の温度特性補正及び周波数特性の安定化。B、X、Y、F特はバイパスコンデンサに最適
- The class 1 temperature compensating (NPO) products can be used in circuits to stabilize frequency and temperature characteristics.
- The B, X, Y and F dielectrics are optimum for bypass capacitors.

形名表記法 ORDERING CODE

1 定格電圧 (VDC)	4 温度特性	5 公称静電容量 (pF)	6 容量許容差 (%)	8 梱包
E 16 T 25 U 50	CH 0± 60(ppm /C) RH -220± 60(ppm /C) UJ -750±120(ppm /C) SL +350~-1000(ppm /C) △B (Y5P) ±10% (単層形) (X5R) ±15% (積層形) △F (Y5V) $\pm \frac{30}{85}\%$ △X (Y5R) ±15% △Y (Y5S) ±22% △=スペース	例 ※R=小数点 010 1 1R2 1.2 103 10000	J- ± 5 K- ±10 M- ±20 N- ±30 Z- ± $\frac{80}{20}$	B つづら折り C 袋づめ
2 形式			7 リード形状 (mm)	9 当社管理記号
P アキシャルリードコンデンサ			A- 26.0テープ幅テーピング B- 52.0テープ幅テーピング KE 7.5ピッチフォーミング (単層タイプ) KF 5.0ピッチフォーミング NA 単品ストレートリード	△△ 単層標準品 △Z 積層標準品 △=スペース
3 形状寸法 (L×φd)(mm)				
050 3.5×1.9(単層形) 3.2×2.2(積層形) 025 2.5×1.9(積層形)				



1 Rated voltage(VDC)	4 Temperature characteristics(ppm/°C)	5 Nominal Capacitance(pF)	6 Capacitance Tolerances(%)	8 Packaging
E 16 T 25 U 50	CH 0± 60 RH -220± 60 UJ -750±120 SL +350~-1000 △B (Y5P) ±10% (monolithic type) (X5R) ±15% (multilayer type) △F (Y5V) $\pm \frac{30}{85}\%$ △X (Y5R) ±15% △Y (Y5S) ±22% △=Blank space	example 010 1 1R2 1.2 103 10000 ※R=decimal point	J- ± 5 K- ±10 M- ±20 N- ±30 Z- ± $\frac{80}{20}$	B Ammo C Bulk
2 Type			7 Lead Configuration	9 Internal code
P Axial leaded capacitors			A- 26mm lead space, ammo pack B- 52mm lead space, ammo pack KE 7.5mm pitch formed lead bulk(monolithic type) KF 5.0mm pitch formed lead bulk NA Axial lead, bulk	△△ Monolithic type Standard products △Z Multilayer type Standard products △=Blank space
3 Outside Dimensions(L×φd)(mm)				
050 3.5×1.9(monolithic type) 3.2×2.2(multilayer type) 025 2.5×1.9(multilayer type)				

外形寸法 EXTERNAL DIMENSIONS

TYPE	Dimensions			テーピング品 Taped product		単品 Bulk Product		
	L	φD	φd	ストレート Straight	ストレート Straight	フォーミング Formed	フォーミング Formed	フォーミング Formed
単層形050 (Monolithic Type)	3.5max (0.138max)	1.9max (0.075max)	0.45±0.05 (0.018±0.002)					
積層形050 (Multilayer Type)	3.2max (0.126max)	2.2max (0.087max)						
積層形025 (Multilayer Type)	2.5max (0.098max)	1.9max (0.075max)	0.40±0.05 (0.016±0.002)					

Unit: mm(inch)

概略バリエーション AVAILABLE CAPACITANCE RANGE

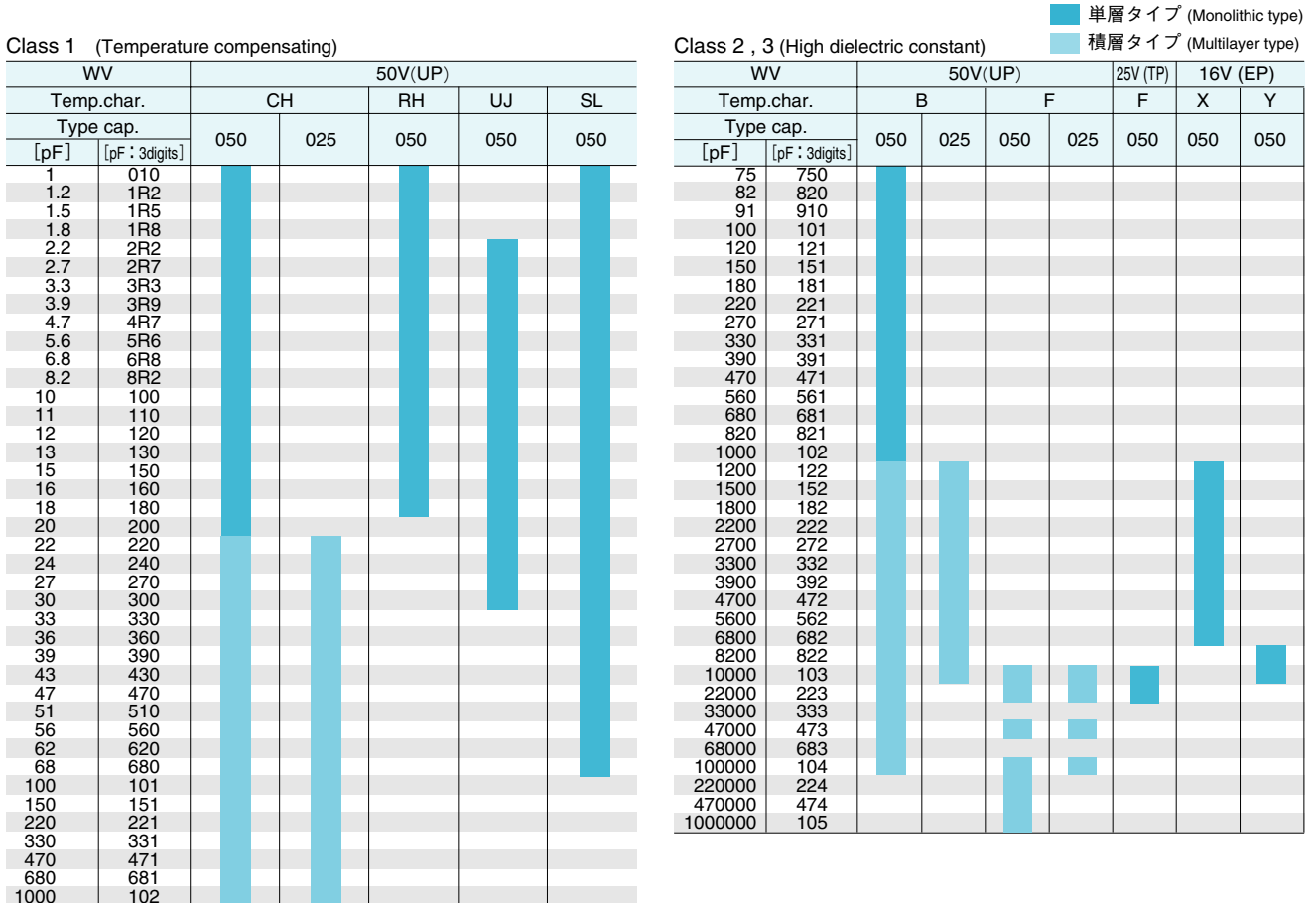

温度特性 Temperature char.	静電容量変化率 Capacitance change	容量許容差 Capacitance Tolerance	Q又はtanδ Q or tanδ	種類 Class
CH	0± 60ppm/°C	1.8pF(and less) : M(±20%) 2.2~8.2pF : K(±10%) 10pF(or over) : J(±5%)	単層タイプ(Monolithic Type) Q≥400+20C 積層タイプ(Multilayer Type) Q≥400+20C, 33pF(and over) Q≥1000 Q≥400+20・C, 16pF(and over) Q≥500 Q≥400+20・C	1
RH	-220± 60ppm/°C	K (±10%)	単層タイプ(Monolithic Type) tanδ≤1.5%, 470pF(and over)tanδ≤2.5%	2, 3
UJ	-750±120ppm/°C		積層タイプ(Multilayer Type) 1200pF~39000pF : tanδ≤3.5% 47000pF~100000pF : tanδ≤5.0%	
SL	+350~-1000ppm/°C		単層タイプ(Monolithic Type) tanδ≤2.5%	3
			積層タイプ(Multilayer Type) tanδ≤7.5%	3
△B	Y5P : ±10% X5R : ±15%	M(±20%), N(±30%)	単層タイプ(Monolithic Type) tanδ≤7.5% 積層(Multilayer Type) 10000pF~100000pF : tanδ≤7.5% 220000pF~470000pF : tanδ≤10.0% 1000000pF : tanδ≤15.0%	2
X(Y5R)	±15%	M(±20%), N(±30%)		3
Y(Y5S)	±22%	M(±20%), N(±30%)		3
△F	Y5V : ±20%	Z(±20%)		2

注1: 温度特性の()はEIA規格相当表示です。
注2: 20°Cにおける静電容量を基準。

Note 1: Temperature characteristics in () are EIA Standard.
Note 2: Capacitance characteristics measured at 20°C

セレクションガイド
Selection Guide

アイテム一覧
Part Numbers

特性図
Electrical Characteristics

梱包
Packaging

信頼性
Reliability Data

使用上の注意
Precautions

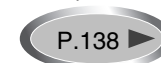
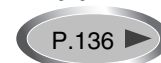

etc

TAIYO YUDEN

アイテム一覧 PART NUMBERS

[単層タイプ Monolithic type]

Class 1

定格電圧 Rated Voltage (DC)	形名 Ordering code	温度特性 Temperature characteristics	公称静電容量 Capacitance [pF]	容量許容差 Capacitance tolerance	Q or tanδ	絶縁抵抗 Insulation resistance
50V	UP050△010M-○	CH RH SL	1.0	±20%	Q≥400+20C (C:公称静電容量 capacitance[pF]) ただしRHは 16pF以上は Q≥500 but Q≥500 at 16pF or over of characteristic RH	10000MΩmin
	UP050△1R2M-○		1.2			
	UP050△1R5M-○		1.5			
	UP050△1R8M-○	1.8	±10%			
	UP050△2R2K-○	2.2				
	UP050△2R7K-○	2.7				
	UP050△3R3K-○	3.3				
	UP050△3R9K-○	3.9				
	UP050△4R7K-○	4.7				
	UP050△5R6K-○	5.6				
	UP050△6R8K-○	6.8				
	UP050△8R2K-○	8.2				
	UP050△100J-○	10		±5%		
	UP050△110J-○	11				
	UP050△120J-○	12				
	UP050△130J-○	13				
	UP050△150J-○	15				
	UP050△160J-○	16				
	UP050△180J-○	18				
	UP050△200J-○	20				
	UP050△220J-○	22				
	UP050△240J-○	24				
	UP050△270J-○	27				
	UP050△300J-○	30	SL			
	UP050SL330J-○	33				
	UP050SL360J-○	36				
	UP050SL390J-○	39				
	UP050SL430J-○	43				
UP050SL470J-○	47					
UP050SL510J-○	51					
UP050SL560J-○	56					
UP050SL620J-○	62					
UP050SL680J-○	68					

形名の△には温度特性、○にはリード形状分類記号が入ります。★：オプション対応

△Please specify the temperature characteristics code and ○ lead configuration code.

★ : Option

[積層025タイプ Multilayer 025 Type]
Class 2

定格電圧 Rated Voltage (DC)	形名 Ordering code	温度特性 Temperature characteristics	公称静電容量 Capacitance [pF]	容量許容差 Capacitance tolerance	Q or tanδ	絶縁抵抗 Insulation resistance
50V	★ UP025CH220J-○Z	CH	22	± 5%	Q _≧ 400+20C	10000MΩmin
	★ UP025CH240J-○Z		24			
	★ UP025CH270J-○Z		27			
	★ UP025CH300J-○Z		30			
	★ UP025CH330J-○Z		33			
	★ UP025CH360J-○Z		36			
	★ UP025CH390J-○Z		39			
	★ UP025CH430J-○Z		43			
	★ UP025CH470J-○Z		47			
	★ UP025CH510J-○Z		51			
	★ UP025CH560J-○Z		56			
	★ UP025CH620J-○Z		62			
	★ UP025CH680J-○Z		68			
	★ UP025CH750J-○Z		75			
	★ UP025CH820J-○Z		82			
	★ UP025CH910J-○Z		91			
	★ UP025CH101J-○Z		100			
	★ UP025CH111J-○Z		110			
	★ UP025CH121J-○Z		120			
	★ UP025CH131J-○Z		130			
	★ UP025CH151J-○Z		150			
	★ UP025CH161J-○Z		160			
	★ UP025CH181J-○Z		180			
	★ UP025CH201J-○Z		200			
	★ UP025CH221J-○Z		220			
	★ UP025CH241J-○Z		240			
	★ UP025CH271J-○Z		270			
	★ UP025CH301J-○Z		300			
	★ UP025CH331J-○Z		330			
	★ UP025CH361J-○Z		360			
	★ UP025CH391J-○Z		390			
	★ UP025CH431J-○Z		430			
	★ UP025CH471J-○Z		470			
★ UP025CH511J-○Z	510					
★ UP025CH561J-○Z	560					
★ UP025CH621J-○Z	620					
★ UP025CH681J-○Z	680					
★ UP025CH751J-○Z	750					
★ UP025CH821J-○Z	820					
★ UP025CH911J-○Z	910					
★ UP025CH102J-○Z	1000					
50V	★ UP025 B122K-○Z	B	1200	±10%	tanδ _≦ 3.5%	5000MΩmin
	★ UP025 B152K-○Z		1500			
	★ UP025 B182K-○Z		1800			
	★ UP025 B222K-○Z		2200			
	★ UP025 B272K-○Z		2700			
	★ UP025 B332K-○Z		3300			
	★ UP025 B392K-○Z		3900			
	★ UP025 B472K-○Z		4700			
	★ UP025 B562K-○Z		5600			
	★ UP025 B682K-○Z		6800			
50V	★ UP025 B822K-○Z	F	8200	± ^{80%} / _{20%}	tanδ _≦ 7.5%	1000MΩmin
	★ UP025 B103K-○Z		10000			
	★ UP025 F103Z-○Z		10000			
	★ UP025 F223Z-○Z		22000			
	★ UP025 F473Z-○Z		47000			
	★ UP025 F104Z-○Z	100000				

アイテム一覧 PART NUMBERS

[積層タイプ Multilayer type]
Class 1

定格電圧 Rated Voltage (DC)	形名 Ordering code	温度特性 Temperature characteristics	公称静電容量 Capacitance [pF]	容量許容差 Capacitance tolerance	Q or tanδ	絶縁抵抗 Insulation resistance
50V	UP050CH220J-○ Z	CH	22	± 5%	Q _≥ 400+20C	10000MΩmin
	★ UP050CH240J-○ Z		24			
	UP050CH270J-○ Z		27			
	★ UP050CH300J-○ Z		30			
	UP050CH330J-○ Z		33			
	★ UP050CH360J-○ Z		36			
	UP050CH390J-○ Z		39			
	★ UP050CH430J-○ Z		43			
	UP050CH470J-○ Z		47			
	★ UP050CH510J-○ Z		51			
	UP050CH560J-○ Z		56			
	★ UP050CH620J-○ Z		62			
	UP050CH680J-○ Z		68			
	★ UP050CH750J-○ Z		75			
	★ UP050CH820J-○ Z		82			
	★ UP050CH910J-○ Z		91			
	UP050CH101J-○ Z		100			
	★ UP050CH111J-○ Z		110			
	★ UP050CH121J-○ Z		120			
	★ UP050CH131J-○ Z		130			
	UP050CH151J-○ Z		150			
	★ UP050CH161J-○ Z		160			
	★ UP050CH181J-○ Z		180			
	★ UP050CH201J-○ Z		200			
	UP050CH221J-○ Z		220			
	★ UP050CH241J-○ Z		240			
	★ UP050CH271J-○ Z		270			
	★ UP050CH301J-○ Z		300			
	UP050CH331J-○ Z		330			
	★ UP050CH361J-○ Z		360			
	★ UP050CH391J-○ Z		390			
	★ UP050CH431J-○ Z		430			
	UP050CH471J-○ Z		470			
	★ UP050CH511J-○ Z		510			
	★ UP050CH561J-○ Z		560			
	★ UP050CH621J-○ Z		620			
	UP050CH681J-○ Z		680			
	★ UP050CH751J-○ Z		750			
	★ UP050CH821J-○ Z		820			
	★ UP050CH911J-○ Z		910			
UP050CH102J-○ Z	1000					

形名の△には温度特性、○にはリード形状分類記号が入ります。 ★：オプション対応

△Please specify the temperature characteristics code and ○ lead configuration code.

★ : Option

[単層タイプ Monolithic type]

Class 2, 3

定格電圧 Rated Voltage (DC)	形名 Ordering code	温度特性 Temperature characteristics	公称静電容量 Capacitance (pF)	容量許容差 Capacitance tolerance	Q or tanδ	絶縁抵抗 Insulation resistance
50V	UP050 B750K-○	B	75	±10%	tanδ≤1.5%	10000MΩmin
	UP050 B820K-○		82			
	UP050 B910K-○		91			
	UP050 B101K-○		100			
	UP050 B121K-○		120			
	UP050 B151K-○		150			
	UP050 B181K-○		180			
	UP050 B221K-○		220			
	UP050 B271K-○		270			
	UP050 B331K-○		330			
	UP050 B391K-○		390			
	UP050 B471K-○		470			
	UP050 B561K-○		560			
	UP050 B681K-○		680			
	UP050 B821K-○		820			
UP050 B102K-○	1000					
16V	EP050 X122□-○	X	1200	±20% ±30%	tanδ≤2.5%	1000MΩmin
	EP050 X152□-○		1500			
	EP050 X182□-○		1800			
	EP050 X222□-○		2200			
	EP050 X272□-○		2700			
	EP050 X332□-○		3300			
	EP050 X392□-○		3900			
	EP050 X472□-○		4700			
	EP050 X562□-○		5600			
	EP050 X682□-○		6800			
	EP050 Y822□-○	8200	Y			
	EP050 Y103□-○	10000				
25V	TP050 F103Z-○	F	10000	± ⁸⁰ / ₂₀ %	tanδ≤7.5%	
	TP050 F223Z-○		22000			

形名の□には容量許容差、○にはリード形状分類記号が入ります。

□Please specify the capacitance tolerance code and ○ lead configuration code.

アイテム一覧 PART NUMBERS

[積層タイプ Multilayer type]

Class 2

定格電圧 Rated Voltage (DC)	形名 Ordering code	温度特性 Temperature characteristics	公称静電容量 Capacitance [pF]	容量許容差 Capacitance tolerance	Q or $\tan\delta$	絶縁抵抗 Insulation resistance
50V	★ UP050 B122K-○ Z	B	1200	±10%	$\tan\delta \leq 3.5\%$	5000MΩmin
	UP050 B152K-○ Z		1500			
	★ UP050 B182K-○ Z		1800			
	UP050 B222K-○ Z		2200			
	★ UP050 B272K-○ Z		2700			
	UP050 B332K-○ Z		3300			
	★ UP050 B392K-○ Z		3900			
	UP050 B472K-○ Z		4700			
	★ UP050 B562K-○ Z		5600			
	UP050 B682K-○ Z		6800			
	★ UP050 B822K-○ Z		8200			
	UP050 B103K-○ Z		10000			
	★ UP050 B123K-○ Z		12000			
	UP050 B153K-○ Z		15000			
	★ UP050 B183K-○ Z		18000			
	UP050 B223K-○ Z		22000			
	★ UP050 B273K-○ Z		27000			
	UP050 B333K-○ Z		33000			
	★ UP050 B393K-○ Z		39000			
	UP050 B473K-○ Z		47000			
★ UP050 B563K-○ Z	56000					
UP050 B683K-○ Z	68000					
★ UP050 B823K-○ Z	82000					
UP050 B104K-○ Z	100000					
50V	UP050 F103Z-○ Z	F	10000	+80 -20 %	$\tan\delta \leq 7.5\%$	1000MΩmin
	UP050 F223Z-○ Z		22000			
	UP050 F473Z-○ Z		47000			
	UP050 F104Z-○ Z		100000		$\tan\delta \leq 10.0\%$	500MΩmin
	UP050 F224Z-○ Z		220000			
	UP050 F474Z-○ Z		470000			
	UP050 F105Z-○ Z		1000000			
				$\tan\delta \leq 15\%$	250MΩmin	

形名の△には温度特性、○にはリード形状分類記号が入ります。 ★：オプション対応

△Please specify the temperature characteristics code and ○ lead configuration code.

★ : Option

・静電容量—温度特性 Capacitance -vs- Temperature Characteristics

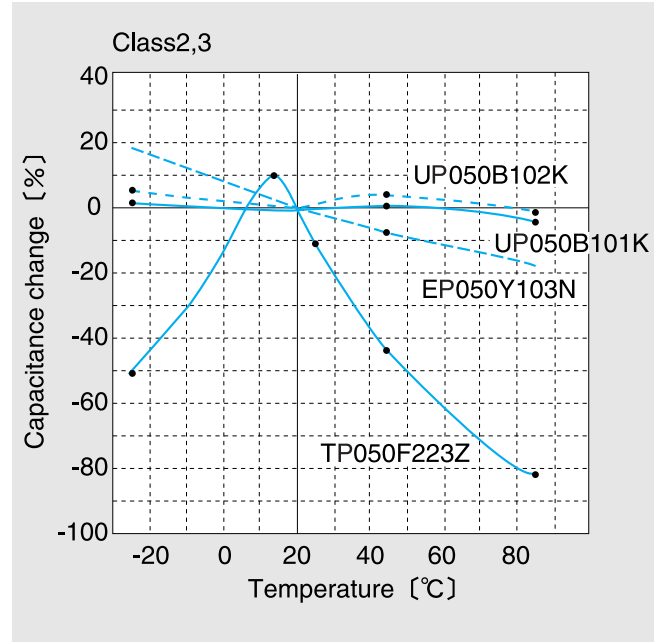
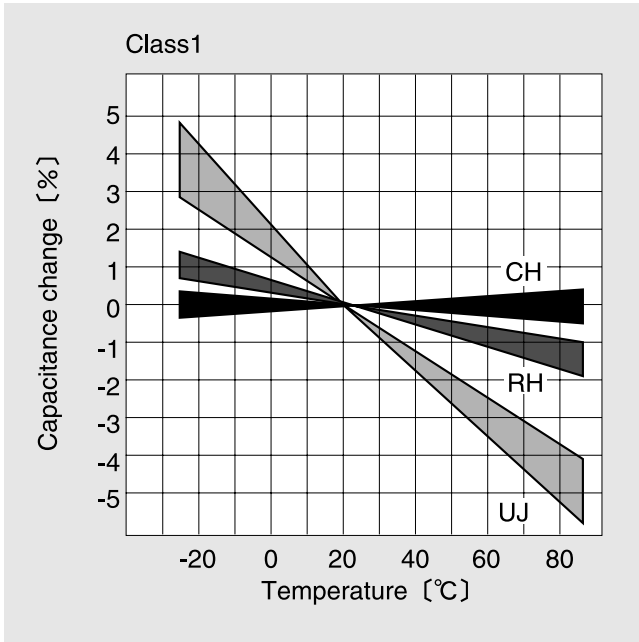

①最小受注単位数 Minimum Quantity

形式 Type	リード形状記号 Lead configuration code	最小受注単位数(PCS) Minimum Quantity	
		袋づめ Bulk	テーピング Taping
積層形 Multilayer type (050, 025)	A-(26mm幅) 1.024 inch wide	—	3000, 4000(025type)
	B-(52mm幅) 2.047 inches wide	—	3000, 4000(025type)
	NA	1000	—
	KF	3000	—
単層形 Monolithic type	A-(26mm幅) 1.024 inch wide	—	4000
	B-(52mm幅) 2.047 inches wide	—	4000
	NA	1000	—
	KF	3000	—
	KE	3000	—

②製品単品形状 Dimensions of Bulk Products

・NA形状 NA configuration

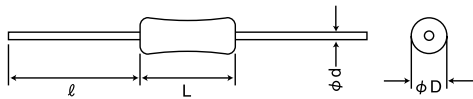

形式 Type	寸法 Dimensions(mm)			
	φD	L	φd	ℓ
積層形 025 Multilayer type	1.9max (0.075)	2.5max (0.098)	0.40±0.05 (0.016±0.002)	20.0min (0.787)
積層形 050 Multilayer type	2.2max (0.087)	3.2max (0.126)	0.45±0.05 (0.018±0.002)	20.0min (0.787)
単層形 Monolithic type	1.9max (0.075)	3.5max (0.138)	0.45±0.05 (0.018±0.002)	20.0min (0.787)

Unit : mm(inch)

・KF/KE形状 KF/KE configuration

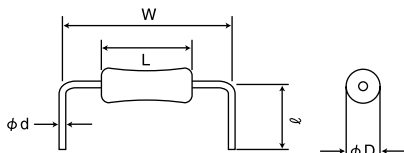

形式 Type	リード形状記号 Lead configuration code	寸法 Dimensions(mm)				
		φD	L	W	φd	ℓ
積層形 025 Multilayer type	KF	1.9max (0.075max)	2.5max (0.098max)	5.0±0.5 (0.197±0.020)	0.40±0.05 (0.016±0.002)	6.5±0.5 (0.256±0.020)
積層形 050 Multilayer type	KF	2.2max (0.087max)	3.2max (0.126max)	5.0±0.5 (0.197±0.020)	0.45±0.05 (0.018±0.002)	6.5±0.5 (0.256±0.020)
単層形 Monolithic type	KF	1.9max (0.075max)	3.5max (0.138max)	5.0±0.5 (0.197±0.020)	0.45±0.05 (0.018±0.002)	6.5±0.5 (0.256±0.020)
単層形 Monolithic type	KE	1.9max (0.075max)	3.5max (0.138max)	7.5±0.5 (0.295±0.020)	0.45±0.05 (0.018±0.002)	6.5±0.5 (0.256±0.020)

Unit : mm(inch)

③テーピング寸法 Taping Dimensions

A-(a : 26mm幅)形状(a : 1.024 inch wide)configuration

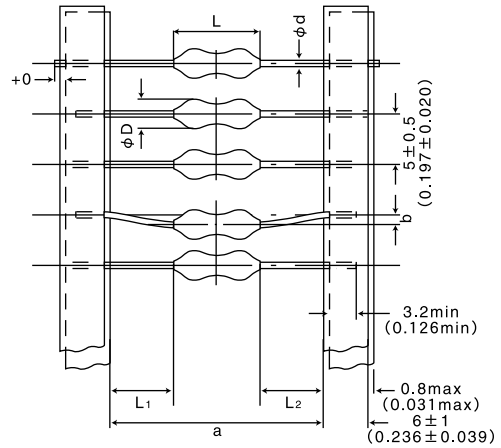

形式 Type	寸法 Dimensions						最小挿入 ピッチ Minimum insertion pitch
	φD	L	a	b	L ₁ -L ₂	φd	
積層形 025 Multilayer type	1.9max (0.075max)	2.5max (0.098max)	26 ^{+0.5} ₋₀ (1.024 ^{+0.020} ₋₀)	0.8以下 (0.031 or less)	0.5max (0.020max)	0.40±0.05 (0.016±0.002)	5.0 (0.197)
積層形 050 Multilayer type	2.2max (0.087max)	3.2max (0.126max)				0.45±0.05 (0.018±0.002)	
単層形 Monolithic type	1.9max (0.075max)	3.5max (0.138max)				0.40±0.05 (0.016±0.002)	

Unit : mm(inch)

B-(a : 52mm幅)形状(a : 2.047 inches wide)configuration

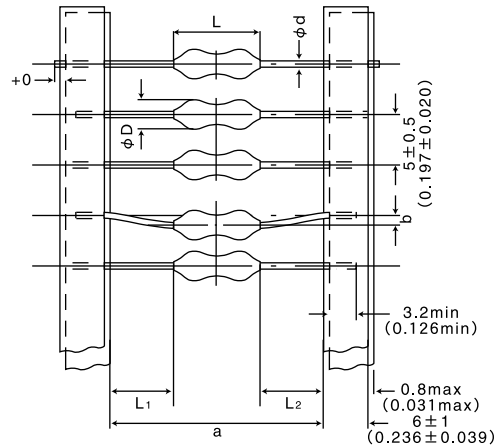

形式 Type	寸法 Dimensions						最小挿入 ピッチ Minimum insertion pitch
	φD	L	a	b	L ₁ -L ₂	φd	
積層形 025 Multilayer type	1.9max (0.075max)	2.5max (0.098max)	52 ⁺² ₋₁ (2.047 ^{+0.079} _{-0.039})	1.2以下 (0.047 or less)	1.0max (0.039max)	0.40±0.05 (0.016±0.002)	5.0 (0.197)
積層形 050 Multilayer type	2.2max (0.087max)	3.2max (0.126max)				0.45±0.05 (0.018±0.002)	
単層形 Monolithic type	1.9max (0.075max)	3.5max (0.138max)				0.40±0.05 (0.016±0.002)	

Unit : mm(inch)

AXIAL LEADED CERAMIC CAPACITORS

Item	Specified Value					Test Methods and Remarks
	Temperature Compensating(Class 1)		High Permittivity(Class 2)		Semiconductor(Class 3)	
	Monolithic type	Multilayer Type	Monolithic type	Multilayer Type	Monolithic type	
1.Operating Temperature Range	-25 to +85°C	-55~+85°C	-25~+85°C	B: -25~+85°C (X5R: -55~+85°C) F: -25~+85°C (Y5V: -30~+85°C)	-25~+85°C	
2.Storage Temperature Range	-25 to +85°C					
3.Rated Voltage	50VDC		50VDC	16VDC,25VDC,50VDC	16VDC,25VDC,50VDC	
4.Withstanding Voltage	Between terminals	No abnormality				Applied voltage: Rated Voltage×3 (Class 1) (Class 2: Monolithic type) Rated Voltage×1.5 (Class 3: B) 18V (Class 3: X, Y) Rated Voltage×2 (Class 2: Multilayer type) (Class 3: F) Rated Voltage×2.5 (Class 2: Multilayer type 50VDC) Duration: 1 to 5 sec. Charge/discharge current: 50mA max. (Class 1,2) 10mA max. (Class 3)
	Between terminals and body	No abnormality				Metal globule method Applied voltage: Rated Voltage×2.5 Duration: 1 to 5 sec. Charge/Discharge current : 50mA max.
5.Insulation Resistance	10,000 MΩ min.		10,000 MΩ min.	Rated voltage: 16 VDC F: 250 MΩ min. Rated voltage: 25 VDC B: 1,000 MΩ min. Rated voltage: 50 VDC B(X5R) : 1200pF~3900pF : 500MΩmin. 47000pF~100000pF : 1000MΩmin. F(Y5V) : 10000pF~100000pF : 1000MΩmin. 220000pF~470000pF : 500MΩmin. 100000pF : 250MΩmin.	1,000 MΩ min.	Applied voltage: Rated voltage Duration : 60±5 sec.
6.Capacitance	1.8 pF or under : ±20% 2.2 pF to 8.2 pF: ±10% 10 pF or over : ±5%	±5%	Rated voltage: 50 VDC B: 75 pF to 560 pF : ±10%	Rated voltage: 16 VDC F: 1,000,000 pF: $\pm 20\%$ Rated voltage: 25 VDC B: 100,000 pF: $\pm 10\%$ Rated voltage: 50 VDC B(X5R): $\pm 10\%$ F(Y5V): $\pm 20\%$	Rated voltage: 16 VDC X: 1,200 pF to 6,800 pF: $\pm 20\%$, $\pm 30\%$ Y: 8,200 pF, 10,000 pF : $\pm 20\%$, $\pm 30\%$ Rated voltage: 25 VDC F: 10,000 pF, 22,000 pF : $\pm 20\%$ Rated voltage: 50 VDC B: 680 pF to 1,000 pF: $\pm 10\%$	Measuring frequency 1MHz±20% (Class 1: Monolithic type) 1kHz±20% (Class 2: Monolithic type) (Class 3) 1MHz±10% (Class 1: Multilayer type C≤1000pF) 1kHz±10% (Class 1: Multilayer type C>1000pF) Rated voltage: 25 VDC Measuring voltage: 1.0±0.5Vrms (Class 1,2) (Class 3: B,X,Y) 0.1Vrms max. (Class 3: F) Measuring temperature: 20°C (Monolithic type) Bias application: None
7.Q or Tangent of Loss Angle	30 pF or under : Q≥400+20C 33 pF or over : Q≥500 16 pF to 18 pF of RH: Q≥500 C= Nominal capacitance [pF]	30 pF or under : Q≥400+20C 30 pF or over : Q≥1000	B: 75 pF to 390 pF: 1.5% max. 470 pF to 560 pF: 2.5% max	Rated voltage: 16 VDC F: 15.0% max. Rated voltage: 25 VDC B: 5.0% max. Rated voltage: 50 VDC B(X5R) : 1200pF~3900pF : 3.5% max. 47000pF~100000pF : 5.0% max. F(Y5V) : 10000pF~100000pF : 7.5% max. 220000pF~470000pF : 10.0% max. 100000pF : 15.0% max.	Rated voltage: 16 VDC X: 2.5% max. Y: 2.5% max. Rated voltage: 25 VDC F: 7.5% max. Rated voltage: 50 VDC B: 2.5% max.	
8.Capacitance Change due to Temperature or Rate of Capacitance Change	(When voltage is not applied)	CH: 0±60 RH: -220±60 UJ: -750±120 SL: +350 to -1,000 [ppm/C]	CH : 0±60 [ppm/C]	B: ±10% Rated voltage: 16 VDC F: $\pm 30\%$ Rated voltage: 25 VDC B: $\pm 10\%$ Rated voltage: 50 VDC B: $\pm 10\%$ (X5R: $\pm 15\%$) F: $\pm 30\%$ (Y5V: $\pm 22\%$)	Rated voltage: 16 VDC X: $\pm 15\%$ Y: $\pm 22\%$ Rated voltage: 25 VDC F: $\pm 30\%$ Rated voltage: 50 VDC B: $\pm 10\%$	Measurement of capacitance at 20°C and 85°C, -25°C shall be made to calculate temperature characteristic by the following equation. (Class 1) $\frac{C_{85} - C_{20}}{C_{20} \times \Delta T} \times 10^6 \text{ (ppm/}^\circ\text{C)}$ $\frac{C_{-25} - C_{20}}{C_{20} \times \Delta T} \times 10^6 \text{ (ppm/}^\circ\text{C)}$ Change of maximum capacitance deviation in step 1 to 5 (Class 2,3) Temperature at step 1: 20°C Temperature at step 4: 85°C Temperature at step 2: -25°C Temperature at step 5: 20°C Temperature at step 3: 20°C (Reference temperature) Reference temperature for X5R and Y5V shall be +25°C

Withstanding voltage is also referred to as "voltage proof" under IEC specifications.

AXIAL LEADED CERAMIC CAPACITORS

Item	Specified Value					Test Methods and Remarks							
	Temperature Compensating(Class 1)		High Permittivity(Class 2)		Semiconductor(Class 3)								
	Monolithic type	Multilayer Type	Monolithic type	Multilayer Type	Monolithic type								
9.Terminal Strength	Tensile	No abnormality such as cut lead, or looseness.					Apply the stated tensile force progressively in the direction to draw terminal. <table border="1"> <thead> <tr> <th>Nominal wire diameter [mm]</th> <th>Tensile force [N]</th> <th>Duration [s]</th> </tr> </thead> <tbody> <tr> <td>0.45</td> <td>19.6</td> <td>5</td> </tr> </tbody> </table>	Nominal wire diameter [mm]	Tensile force [N]	Duration [s]	0.45	19.6	5
	Nominal wire diameter [mm]	Tensile force [N]	Duration [s]										
0.45	19.6	5											
Torsional	No abnormalities, such as cuts or looseness of terminals.					Suspend a mass at the end the terminal, incline the body through angle of 90° and return it to initial position. This operation is done over a period of 5 sec. Then second bend in the opposite direction shall be made. Number of bends : 2 times <table border="1"> <thead> <tr> <th>Nominal wire diameter [mm]</th> <th>Bending force [N]</th> <th>Mass weight [kg]</th> </tr> </thead> <tbody> <tr> <td>0.45</td> <td>2.45</td> <td>0.25</td> </tr> </tbody> </table>	Nominal wire diameter [mm]	Bending force [N]	Mass weight [kg]	0.45	2.45	0.25	
Nominal wire diameter [mm]	Bending force [N]	Mass weight [kg]											
0.45	2.45	0.25											
10.Resistance to Vibration	Appearance: No significant abnormality Capacitance change: 1.8 pF or under : Within ±20% 2.2 pF to 8.2 pF: Within ±10% 10 pF or over : Within ± 5% Q : 30 pF or under : Q≥400+20C 33 pF or over : Q≥500 16 pF to 18 pF of RH: Q≥500 C= Nominal capacitance [pF] Insulation resistance: 10,000 MΩ min. Withstanding voltage: No abnormality	Appearance: No significant abnormality Capacitance change: Within ±5% Q : 30 pF or under : Q≥400+20C 30 pF or over : Q≥1000 Insulation resistance: 10,000 MΩ min. Withstanding voltage: No abnormality	Appearance: No significant abnormality Capacitance change: Within ±10% tan δ: 75 pF to 390 pF: 1.5% max. 470 pF to 560 pF: 2.5% max. Insulation resistance: 10,000 MΩ min. Withstanding voltage: No abnormality	Rated voltage: 16VDC Appearance: No significant abnormality Capacitance change: Within ^{+80%} _{-20%} tan δ: 15.0% max. Insulation resistance: 250 MΩmin. Withstanding voltage: No abnormality Rated voltage: 25 VDC, Appearance: No significant abnormality Capacitance change: Within ±10% tan δ: 5.0% max. Insulation resistance: 1,000 MΩ min. Withstanding voltage: No abnormality Rated voltage: 50 VDC Appearance: No significant abnormality B(X5R) Capacitance change: Within±10 % tan δ : 1200pF~39000pF : 3.5%max. 47000pF~100000pF : 5.0%max. Insulation resistance: 1200pF~39000pF : 5000MΩmin. 47000pF~100000pF: 1000MΩmin. F(Y5V) Capacitance change: Within ^{+80%} _{-20%} tan δ : 10000pF~100000pF: 7.5%max. 220000pF~470000pF: 10.0%max. 1000000pF : 15.0%max. Insulation resistance: 10000pF~100000pF: 1000MΩmin. 220000pF~470000pF: 500MΩmin. 1000000pF : 250MΩmin.	Rated voltage: 16 VDC Appearance: No significant abnormality Capacitance change : Within ±20%, Within ±30% tan δ : 2.5% max. Insulation resistance:1,000 MΩ min. Withstanding voltage: No abnormality Rated voltage: 25 VDC Appearance: No significant abnormality Capacitance change: Within ^{+80%} _{-20%} tan δ : 7.5% max. Insulation resistance:1,000 MΩ min. Withstanding voltage: No abnormality Rated voltage: 50 VDC Appearance: No significant abnormality Capacitance change: Within ±10% tan δ : 2.5% max. Insulation resistance: 1,000 MΩ min. Withstanding voltage: No abnormality	According to JIS C 5102 clause 8.2 Vibration type: A Directions: 2 hrs each in X,Y and Z directions Total: 6 hrs Frequency range: 10 to 55 to 10Hz(1 min) Amplitude: 1.5 mm Mounting method: Soldering onto the PC board							
11.Free Fall	Appearance: No significant abnormality Capacitance change: 1.8 pF or under : Within ±20% 2.2 pF to 8.2 pF: Within ±10% 10 pF or over : Within ± 5% Q: 30 pF or under : Q≥400+20C 33 pF or over : Q≥500 16 pF to 18 pF of RH: Q≥500 C= Nominal capacitance [pF] Insulation resistance: 10,000 MΩ min. Withstanding voltage: No abnormality	Appearance: No significant abnormality Capacitance change: Within ±5% Q: 30 pF or under : Q≥400+20C 30 pF or over : Q≥1000 Insulation resistance: 10,000 MΩ min. Withstanding voltage: No abnormality	Rated voltage: 50 VDC Appearance: No significant abnormality Capacitance change: Within ±10% tan δ: 75 pF to 390 pF: 1.5% max. 470 pF to 560 pF: 2.5% max. Insulation resistance: 10,000 MΩ min. Withstanding voltage: No abnormality	Rated voltage: 16 VDC Appearance: No significant abnormality Capacitance change: Within ^{+80%} _{-20%} tan δ: 15.0% max. Insulation resistance: 250 MΩ min. Withstanding voltage: No abnormality Rated voltage: 25 VDC, Appearance: No significant abnormality Capacitance change: Within ±10% tan δ: 5.0% max. Insulation resistance: 1,000 MΩ min. Withstanding voltage: No abnormality Rated voltage: 50 VDC Appearance: No significant abnormality B(X5R) Capacitance change: Within±10 % tan δ : 1200pF~39000pF : 3.5%max. 47000pF~100000pF : 5.0%max. Insulation resistance: 1200pF~39000pF : 5000MΩmin. 47000pF~100000pF: 1000MΩmin. F(Y5V) Capacitance change: Within ^{+80%} _{-20%} tan δ : 10000pF~100000pF: 7.5%max. 220000pF~470000pF: 10.0%max. 1000000pF : 15.0%max. Insulation resistance: 10000pF~100000pF: 1000MΩmin. 220000pF~470000pF: 500MΩmin. 1000000pF : 250MΩmin.	Rated voltage: 16 VDC Appearance: No significant abnormality Capacitance change: Within ±20%, Within ±30% tan δ : 2.5% max. Insulation resistance: 1000 MΩ min. Withstanding voltage: No abnormality Rated voltage: 25 VDC Appearance: No significant abnormality Capacitance change: Within ±10% tan δ : 2.5% max. Insulation resistance: 1,000 MΩ min. Withstanding voltage: No abnormality	Drop Test: Free fall Impact material: Floor Height: 1 m Total number of drops: 5 times							

Withstanding voltage is also referred to as "voltage proof" under IEC specifications.

AXIAL LEADED CERAMIC CAPACITORS

Item	Specified Value					Test Methods and Remarks																		
	Temperature Compensating(Class 1)		High Permittivity(Class 2)		Semiconductor (Class 3)																			
	Monolithic type	Multilayer Type	Monolithic type	Multilayer Type	Monolithic type																			
12.Body Strength	No abnormality such as damage					Applied force: 19.6N Duration: 5 sec. Speed: Shall attain to specified force in 2 sec.																		
13.Solderability	At least 75% of lead surface is covered with new solder.					Solder temperature: 230±5°C Duration: 2±0.5 sec. (This test may be applicable after 6 months storage.)																		
14.Soldering	Appearance: No significant abnormality Capacitance change: 1.0 pF to 4.7pF : Within ±0.25 pF 5.6 pF or over : Within ±5% Q: 30 pF or under : Q≥400+20C 33 pF or over : Q≥500 16 pF to 18 pF of RH: Q≥500 C= Nominal capacitance [pF] Insulation resistance: 10,000 MΩ min. Withstanding voltage: No abnormality	Appearance: No significant abnormality Capacitance change: Within ±2.5% Q : 30 pF or under : Q≥400+20C 30 pF or over : Q≥1000 Insulation resistance: 10,000 MΩ min. Withstanding voltage: No abnormality	Rated voltage: 50 VDC Appearance: No significant abnormality Capacitance change: Within ±10% tan δ: 75 pF to 390 pF: 1.5% max. 470 pF to 560 pF: 2.5% max. Insulation resistance: 10,000 MΩ min. Withstanding voltage: No abnormality	Rated voltage: 16 VDC Appearance: No significant abnormality Capacitance change: Within ±20% tan δ: 15.0% max. Insulation resistance: 250 MΩ min. Withstanding voltage: No abnormality Rated voltage: 25 VDC, Appearance: No significant abnormality Capacitance change: Within ±10% tan δ: 5.0% max. Insulation resistance: 1,000 MΩ min. Withstanding voltage: No abnormality Rated voltage: 50 VDC Appearance: No significant abnormality B(X5R) Capacitance change: 1200pF~39000pF : Within 7.5% 47000pF~100000pF : Within 10.0% tan δ : 1200pF~39000pF : 3.5%max. 47000pF~100000pF : 5.0%max. Insulation resistance: 1200pF~39000pF : 500MΩmin. 47000pF~100000pF : 1000MΩmin. F(Y5V) Capacitance change: 10000pF~100000pF : Within 20.0% tan δ : 10000pF~100000pF : 7.5%max. 220000pF~470000pF : 10.0%max. 1000000pF : 15.0%max. Insulation resistance: 1000pF~10000pF : 1000MΩmin. 22000pF~47000pF : 500MΩmin. 100000pF : 250MΩmin. Withstanding voltage: No abnormality	Rated voltage: 16 VDC Appearance: No significant abnormality Capacitance change: Within ±10% tan δ: 2.5% max. Insulation resistance: 1,000 MΩ min. Withstanding voltage: No abnormality Rated voltage: 25 VDC Appearance: No significant abnormality Capacitance change: Within ±30% tan δ: 7.5% max. Insulation resistance: 1,000 MΩ min. Withstanding voltage: No abnormality Rated voltage: 50 VDC Appearance: No significant abnormality Capacitance change: Within ±10% tan δ: 2.5% max. Insulation resistance: 1,000 MΩ min. Withstanding voltage: No abnormality	(Class 1, Class 2: Monolithic type, Class 3) Solder temperature: 350±10°C Duration: 3 ^{+0.5} _{-1.0} sec. or Solder temperature: 260±5°C Duration: 10±1 sec. Immersed conditions: Inserted into the PC board (with t=1.6mm, hole=1.0mm diameter) Recovery: 4 to 24 hrs of recovery under the standard condition after the test. (Class 2: Multilayer type) Solder temperature: 270±5°C Duration: 5±0.5 sec. Immersed conditions: Inserted into the PC board (with t=1.6mm, hole=1.0mm diameter) Preconditioning: 1 hr of preconditioning at 150 ⁺⁰ ₋₁₀ °C followed by 48±4 hrs of recovery under the standard condition. Recovery: 48±4 hrs of recovery under the standard condition after the test.																		
15.Resistance to Solvent	No abnormality in appearance and legible marking.					According to JIS C 5102 clause 8.7.4. Type of test: Method 1 Solvent temperature: 20 to 25°C Duration: 30±5 sec. Solvent Type: A in Table 23, Isopropyl alcohol																		
16.Thermal Shock	Appearance: No significant abnormality Capacitance change: 1.0 pF to 10 pF : Within ±0.5pF 11 pF or over : Within ±5% Q : Under 10 pF : Q≥200+10C 10 pF to 30 pF: Q≥275+2.5C 33 pF or over: Q≥250 16 pF to 18 pF of RH: Q≥250 C= Nominal capacitance [pF] Insulation resistance: 1,000 MΩ min. Withstanding voltage: No abnormality	Appearance: No significant abnormality Capacitance change: Within ±5% Q : 30 pF or under : Q≥275+2.5C 30 pF or over : Q≥350 Insulation resistance: 1,000 MΩ min. Withstanding voltage: No abnormality	Rated voltage: 50 VDC Appearance: No significant abnormality Capacitance change: Within ±10% tan δ: 75 pF to 390 pF: 2.5% max. 470 pF to 560 pF: 4% max. Insulation resistance: 1,000 MΩ min. Withstanding voltage: No abnormality	Rated voltage: 16 VDC Appearance: No significant abnormality Capacitance change: Within ±30% tan δ: 17.5% max. Insulation resistance: 50 MΩ min. Withstanding voltage: No abnormality Rated voltage: 25 VDC, Appearance: No significant abnormality Capacitance change: Within ±15% tan δ: 7.5% max. Insulation resistance: 500 MΩ min. Withstanding voltage: No abnormality Rated voltage: 50 VDC Appearance: No significant abnormality B(X5R) Capacitance change: 1200pF~39000pF : Within 12.5% 47000pF~100000pF : Within 15.0% tan δ : 1200pF~39000pF : 5.0%max. 47000pF~100000pF : 7.5%max. Insulation resistance: 1200pF~39000pF : 1000MΩmin. 47000pF~100000pF : 500MΩmin. F(Y5V) Capacitance change: 10000pF~100000pF : Within 30.0% tan δ : 10000pF~100000pF : 12.5%max. 220000pF~470000pF : 15.0%max. 1000000pF : 17.5%max. Insulation resistance: 1000pF~10000pF : 1000MΩmin. 22000pF~47000pF : 250MΩmin. 100000pF : 50MΩmin. Withstanding voltage: No abnormality	Rated voltage: 16 VDC Appearance: No significant abnormality Capacitance change: Within ±10% tan δ: 4% max. Insulation resistance: 500 MΩ min. Withstanding voltage: No abnormality Rated voltage: 25 VDC Appearance: No significant abnormality Capacitance change: Within ±30% tan δ: 12.5% max. Insulation resistance: 500 MΩ min. Withstanding voltage: No abnormality Rated voltage: 50 VDC Appearance: No significant abnormality Capacitance change: Within ±10% tan δ: 4% max. Insulation resistance: 500 MΩ min. Withstanding voltage: No abnormality	Conditions for 1 cycle <table border="1"> <thead> <tr> <th>Step</th> <th>Temperature [°C]</th> <th>Duration [min]</th> </tr> </thead> <tbody> <tr> <td>1</td> <td>Room temperature</td> <td>Within 3</td> </tr> <tr> <td>2</td> <td>-25⁺⁰₋₃</td> <td>30±3</td> </tr> <tr> <td>3</td> <td>Room temperature</td> <td>Within 3</td> </tr> <tr> <td>4</td> <td>+85⁺³₋₀</td> <td>30±3</td> </tr> <tr> <td>5</td> <td>Room temperature</td> <td>Within 3</td> </tr> </tbody> </table> Number of cycles: 5 Preconditioning: 1 hr of preconditioning at 150 ⁺⁰ ₋₁₀ °C followed by 48±4 hrs of recovery under the standard condition. (Class 2: Multilayer type) Recovery: 1 hr of recovery under the standard condition after the removal from test chamber. (Monolithic type) 48±4 hrs of recovery under the standard condition after the removal from test chamber. (Class 2: Multilayer type)	Step	Temperature [°C]	Duration [min]	1	Room temperature	Within 3	2	-25 ⁺⁰ ₋₃	30±3	3	Room temperature	Within 3	4	+85 ⁺³ ₋₀	30±3	5	Room temperature	Within 3
Step	Temperature [°C]	Duration [min]																						
1	Room temperature	Within 3																						
2	-25 ⁺⁰ ₋₃	30±3																						
3	Room temperature	Within 3																						
4	+85 ⁺³ ₋₀	30±3																						
5	Room temperature	Within 3																						

Withstanding voltage is also referred to as "voltage proof" under IEC specifications.
 Thermal Shock is also referred to as "rapid change of temperature" under IEC specifications.

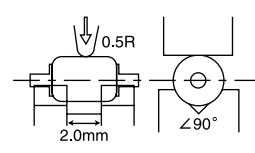

AXIAL LEADED CERAMIC CAPACITORS

Item	Specified Value					Test Methods and Remarks
	Temperature Compensating(Class 1)		High Permittivity(Class 2)		Semiconductor (Class 3)	
	Monolithic type	Multilayer Type	Monolithic type	Multilayer Type	Monolithic type	
17.Damp Heat (steady state)	Appearance: No significant abnormality Capacitance change: 1.0 pF to 10 pF : Within ±0.5pF 11 pF or over : Within ± 5% Q: Under 10 pF : Q≥200+10C 10 pF to 30 pF: Q≥275+2.5C 33 pF or over : Q≥250 16 pF to 18 pF of RH: Q≥250 C= Nominal capacitance [pF] Insulation resistance: 1,000 MΩ min. Withstanding voltage: No abnormality	Appearance: No significant abnormality Capacitance change: Within ±5% Q : 30 pF or under : Q≥275+2.5C 30 pF or over : Q≥350 Insulation resistance: 1,000 MΩ min. Withstanding voltage: No abnormality	Rated voltage: 50 VDC Appearance: No significant abnormality Capacitance change: Within ±10% tan δ: 75 pF to 390 pF: 2.5% max. 470 pF to 560 pF: 4% max. Insulation resistance: 1,000 MΩ min. Withstanding voltage: No abnormality	Rated voltage: 16 VDC Appearance: No significant abnormality Capacitance change: Within ±30% tan δ: 17.5% max. Insulation resistance: 50 MΩ min. Withstanding voltage: No abnormality Rated voltage: 25 VDC, Rated voltage: 50 VDC Appearance: No significant abnormality B(X5R) Capacitance change: 1200pF~39000pF : Within 12.5% 47000pF~100000pF : Within 15.0% tanδ : 1200pF~39000pF : 5.0%max. 47000pF~100000pF : 7.5%max. Insulation resistance: 1200pF~39000pF : 1000MΩmin. 47000pF~100000pF: 500MΩmin. F(Y5V) Capacitance change: 10000pF~100000pF: Within30.0% tanδ : 10000pF~100000pF: 12.5%max. 220000pF~470000pF: 15.0%max. 1000000pF : 17.5%max. Insulation resistance: 10000pF~100000pF: 500MΩmin. 220000pF~470000pF: 250MΩmin. 1000000pF : 50MΩmin. Withstanding voltage: No abnormality	Rated voltage: 16 VDC Appearance: No significant abnormality Capacitance change: Within ±10% tan δ: 4% max. Insulation resistance: 500 MΩ min. Withstanding voltage: No abnormality Rated voltage: 25 VDC Appearance: No significant abnormality Capacitance change: Within ±30% tan δ: 12.5% max. Insulation resistance: 500 MΩ min. Withstanding voltage: No abnormality Rated voltage: 50 VDC Appearance: No significant abnormality Capacitance change: Within ±10% tan δ: 4% max. Insulation resistance: 500 MΩ min. Withstanding voltage: No abnormality	Temperature: 40±2°C Humidity: 90 to 95 % RH Duration: 500 ± ²⁴ ₀ hrs Preconditioning: 1 hr of preconditioning at 150 ± ⁰ ₁₀ C followed by 48±4 hrs of recovery under the standard condition. (Class 2: Multilayer type) Recovery: 1 hr of recovery under the standard condition after the removal from test chamber. (Monolithic type) 24±2 hrs of recovery under the standard condition after the removal from test chamber. (Class 1: Multilayer type) 48±4 hrs of recovery under the standard condition after the removal from test chamber. (Class 2: Multilayer type)
18.Loading under Damp Heat	Appearance: No significant abnormality Capacitance change: 1.0 pF to 10 pF : Within ±0.75pF 11 pF or over : Within ±7.5% Q: 30 pF or under: Q≥100+ ¹⁰ / ₃ C 33 pF or over : Q≥125 16 pF to 18 pF of RH: Q≥125 C= Nominal capacitance [pF] Insulation resistance: 500 MΩ min. Withstanding voltage: No abnormality	Appearance: No significant abnormality Capacitance change: Within ±7.5% Q : 30 pF or under : Q≥100+10/3 · C 30 pF or over : Q≥200 Insulation resistance: 500 MΩ min. Withstanding voltage: No abnormality	Rated voltage: 50 VDC Appearance: No significant abnormality Capacitance change: Within ±10% tan δ: 75 pF to 390 pF: 2.5% max. 470 pF to 560 pF: 5% max. Insulation resistance: 500 MΩ min. Withstanding voltage: No abnormality	Rated voltage: 16 VDC Appearance: No significant abnormality Capacitance change: Within ±30% tan δ: 17.5% max. Insulation resistance: 25 MΩ min. Withstanding voltage: No abnormality Rated voltage: 25 VDC, Rated voltage: 50 VDC Appearance: No significant abnormality B(X5R) Capacitance change: 1200pF~39000pF : Within 12.5% 47000pF~100000pF : Within 15.0% tanδ : 1200pF~39000pF : 5.0%max. 47000pF~100000pF : 7.5%max. Insulation resistance: 1200pF~39000pF : 500MΩmin. 47000pF~100000pF: 250MΩmin. F(Y5V) Capacitance change: 10000pF~100000pF: Within30.0% tanδ : 10000pF~100000pF: 12.5%max. 220000pF~470000pF: 15.0%max. 1000000pF : 17.5%max. Insulation resistance: 10000pF~100000pF : 250MΩmin. 220000pF~470000pF : 125MΩmin. 1000000pF : 25MΩmin. Withstanding voltage: No abnormality	Rated voltage: 16 VDC Appearance: No significant abnormality Capacitance change: Within ±10% tan δ: 5% max. Insulation resistance: 250 MΩ min. Withstanding voltage: No abnormality Rated voltage: 25 VDC Appearance: No significant abnormality Capacitance change: Within ±30% tan δ: 12.5% max. Insulation resistance: 250 MΩ min. Withstanding voltage: No abnormality Rated voltage: 50 VDC Appearance: No significant abnormality Capacitance change: Within ±10% tan δ: 5% max. Insulation resistance: 250 MΩ min. Withstanding voltage: No abnormality	Temperature: 40±2°C Humidity: 90 to 95 % RH Duration: 500 ± ²⁴ ₀ hrs Applied voltage: Rated voltage Preconditioning: Voltage treatment (Class 2: Multilayer type) Recovery: 1 hr of recovery under the standard condition after the removal from test chamber. (Class 1, Class 2: Monolithic type) 24±2 hrs of recovery under the standard condition after the removal from test chamber. (Class 1: Multilayer type) 48±4 hrs of recovery under the standard condition after the removal from test chamber. (Class 2: Multilayer type) 30 min. of conditioning at 150±3°C followed by 1 hr of recovery under the standard condition after the removal from test chamber. (Class 3)

Withstanding voltage is also referred to as "voltage proof" under IEC specifications.

AXIAL LEADED CERAMIC CAPACITORS

Item	Specified Value					Test Methods and Remarks
	Temperature Compensating(Class 1)		High Permittivity(Class 2)		Semiconductor (Class 3)	
	Monolithic type	Multilayer Type	Monolithic type	Multilayer Type	Monolithic type	
19. High Temperature Loading Test	Appearance: No significant abnormality Capacitance change: 1.0 pF to 10 pF : Within ±0.3pF 11 pF or over : Within ± 3% Q: Under 10 pF : Q≥200+10C 10 pF to 30 pF : Q≥275+2.5C 33 pF or over : Q≥250 16 pF to 18 pF of RH: Q≥250 C= Nominal capacitance [pF] Insulation resistance: 1,000 MΩ min. Withstanding voltage: No abnormality	Appearance: No significant abnormality Capacitance change: Within ± 3% Q : 30 pF or under : Q≥275+2.5C 30 pF or over : Q≥350 Insulation resistance: 1,000 MΩ min. Withstanding voltage: No abnormality	Rated voltage: 50 VDC Appearance: No significant abnormality Capacitance change: Within ±10% tan δ: 75 pF to 390 pF: 2.5% max. 470 pF to 560 pF: 4% max. Insulation resistance: 1,000 MΩ min. Withstanding voltage: No abnormality	Rated voltage: 16 VDC Appearance: No significant abnormality Capacitance change: Within ±30% tan δ: 17.5% max. Insulation resistance: 50 MΩ min. Withstanding voltage: No abnormality Rated voltage: 25 VDC, Rated voltage: 50 VDC Appearance: No significant abnormality B(X5R) Capacitance change: 1200pF~3900pF : Within 12.5% 47000pF~10000pF : Within 15.0% tan δ : 1200pF~3900pF : 5.0%max. 47000pF~10000pF : 7.5%max. Insulation resistance: 1200pF~3900pF : 1000MΩmin. 47000pF~10000pF: 500MΩmin. F(Y5V) Capacitance change: 10000pF~100000pF: Within30.0% tan δ : 10000pF~100000pF: 10.0%max. 220000pF~470000pF: 12.5%max. 1000000pF : 17.5%max. Insulation resistance: 10000pF~100000pF: 500MΩmin. 220000pF~470000pF: 250MΩmin. 1000000pF : 50MΩmin. Withstanding voltage: No abnormality	Rated voltage: 16 VDC Appearance: No significant abnormality Capacitance change: Within ±10% tan δ: 4% max. Insulation resistance: 500MΩ min. Withstanding voltage: No abnormality Rated voltage: 25 VDC Appearance: No significant abnormality Capacitance change: Within ±30% tan δ: 10% max. Insulation resistance: 500MΩ min. Withstanding voltage: No abnormality Rated voltage: 50 VDC Appearance: No significant abnormality Capacitance change: Within ±10% tan δ: 4% max. Insulation resistance: 500 MΩ min. Withstanding voltage: No abnormality	Temperature: 85 ± ₃ °C Duration: 1000 ⁺⁴⁸ ₋₀ hrs Applied voltage: Rated voltage×2 (Class 1) (Class 2) Rated voltage×1.5 (Class 3: B, F) Rated voltage×1.125 (Class 3: X, Y) Preconditioning: Voltage treatment (Class 2: Multilayer type) Recovery: 1 hr of recovery under the standard condition after the removal from test chamber. (Class 1, Class 2: Monolithic type) 24±2hrs of recovery under the standard condition after the removal from test chamber. (Class1:Multilayer type) 48±4 hrs of recovery under the standard condition after the removal from test chamber. (Class 2: Multilayer type) As for Class2:Multilayer type B:47000pF~100000pF F:220000pF~1000000pF 1hr of conditioning at 150 ⁺⁰ ₋₁₀ °C followed by 48±4 Hr of recovery under the standard condition after the removal from test chamber. 30 min. of conditioning at 150±3°C followed by 1 hr of recovery under the standard condition after the removal from test chamber. (Class 3)

Note on standard condition: "standard condition" referred to herein is defined as follows: 5 to 35°C of temperature, 45 to 85% relative humidity, and 86 to 106kPa of air pressure.

When there are questions concerning measurement results:

In order to provide correlation data, the test shall be conducted under condition of 20±2°C of temperature, 60 to 70% relative humidity, and 86 to 106kPa of air pressure. Unless otherwise specified, all the tests are conducted under the "standard condition."

Withstanding voltage is also referred to as "voltage proof" under IEC specifications.

Precautions on the use of Axial Leaded Ceramic Capacitors

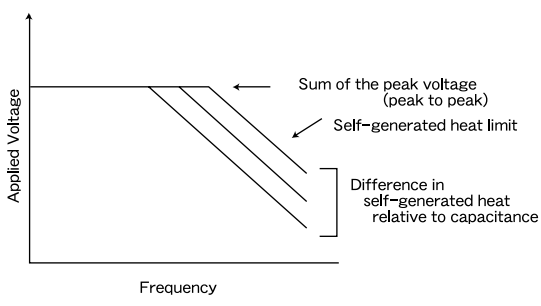
Stages	Precautions	Technical considerations
<p>1. Circuit Design</p>	<p>◆Verification of operating environment, electrical rating and performance</p> <p>1. A malfunction in medical equipment, spacecraft, nuclear reactors, etc. may cause serious harm to human life or have severe social ramifications. As such, any capacitors to be used in such equipment may require higher safety and/or reliability considerations and should be clearly differentiated from components used in general purpose applications.</p> <p>◆Verification of Rated voltage (DC rated voltage)</p> <p>1. The operating voltage for capacitors must always be lower than their rated values.</p> <p>If an AC voltage is loaded on a DC voltage, the sum of the two peak voltages should be lower than the rated value of the capacitor chosen. For a circuit where both an AC and a pulse voltage may be present, the sum of their peak voltages should also be lower than the capacitor's rated voltage.</p> <p>2. Even if the applied voltage is lower than the rated value, the reliability of capacitors might be reduced if either a high frequency AC voltage or a pulse voltage having rapid rise time is present in the circuit.</p> <p>◆Self-generated heat (Verification of Temperature)</p> <p>1. If the capacitors specified only for DC use are used in AC or pulse circuits, the AC or a pulse current can generate heat inside the capacitor so the self-generated temperature rise should be limited to within 20°C. The surface temperature measured should include this self-temperature rise. Therefore, it is required to limit capacitor surface temperature including self-generated heat should not exceed the maximum operating temperature of +85°C.</p> <p>◆Operating Environment precautions</p> <p>1. Capacitors should not be used in the following environments:</p> <p>(1)Environmental conditions to avoid</p> <p>a. exposure to water or salt water.</p> <p>b. exposure to moisture or condensation.</p> <p>c. exposure to corrosive gases (such as hydrogen sulfide, sulfuric acid, chlorine, and ammonia)</p>	<p>1-1. When an AC or a pulse voltage is applied to capacitors specified for DC use, even if the voltage is less than the rated voltage, the AC current or pulse current running through the capacitor will cause the capacitor to self-generate heat because of the loss characteristics.</p> <p>The amount of heat generated depends on the dielectric materials used, capacitance, applied voltage, frequency, voltage waveform, etc. The surface temperature changes due to emitted heat which differs by capacitor shape or mounting method.</p> <p>Please contact Taiyo Yuden with any questions regarding emitted heat levels in your particular application. It is recommended the temperature rise be measured in the actual circuit to be used.</p> <p>1-2. For capacitors, the voltage and frequency relationship is generally determined by peak voltage at low frequencies, and by self-generated heat at high frequencies. (Refer to the following curve.)</p> 
<p>2. PCB Design</p>	<p>1. When capacitors are mounted onto a PC board, hole dimensions on the board should match the lead pitch of the component, if not it will cause breakage of the terminals or cracking of terminal roots covered with resin as excess stress travels through the terminal legs. As a result, humidity resistance performance would be lost and may lead to a reduction in insulation resistance and cause a withstand voltage failure.</p>	
<p>3. Considerations for automatic insertion</p>	<p>◆Adjustment Automatic Insertion machines (leaded components)</p> <p>1. When inserting capacitors in a PC board by auto-insertion machines the impact load imposed on the capacitors should be minimized to prevent the leads from chucking or clinching.</p>	

Precautions on the use of Axial Leaded Ceramic Capacitors

Stages	Precautions	Technical considerations
4. Soldering	<p>◆Selection of Flux</p> <ol style="list-style-type: none"> When soldering capacitors on the board, flux should be applied thinly and evenly. Flux used should be with less than or equal to 0.1 wt% (equivalent to Chlorine) of halogenated content. Flux having a strong acidity content should not be applied. When using water-soluble flux, special care should be taken to properly clean the boards. <p>◆Wave Soldering</p> <ol style="list-style-type: none"> Temperature, time, amount of solder, etc. are specified in accordance with the following recommended conditions. Do not immerse the entire capacitor in the flux during the soldering operation. Only solder the lead wires on the bottom of the board. 	<ol style="list-style-type: none"> Flux is used to increase solderability in wave soldering, but if too much is applied, a large amount of flux gas may be emitted and may detrimentally affect solderability. To minimize the amount of flux applied, it is recommended to use a flux-bubbling system. With too much halogenated substance (Chlorine, etc.) content is used to activate the flux, an excessive amount of residue after soldering may lead to corrosion of the terminal electrodes or degradation of insulation resistance on the surface of the capacitors. Since the residue of water-soluble flux is easily dissolved by water content in the air, the residue on the surface of capacitors in high humidity conditions may cause a degradation of insulation resistance and therefore affect the reliability of the components. The cleaning methods and the capability of the machines used should also be considered carefully when selecting water-soluble flux. <ol style="list-style-type: none"> If capacitors are used beyond the range of the recommended conditions, heat stresses may cause cracks inside the capacitors, and consequently degrade the reliability of the capacitors. When the capacitors are dipped in solder, some soldered parts of the capacitor may melt due to solder heat and cause short-circuits or cracking of the ceramic material. Deterioration of the resin coating may lower insulation resistance and cause a reduction of withstand voltage.
5. Cleaning	<p>◆Board cleaning</p> <ol style="list-style-type: none"> When cleaning the mounted PC boards, make sure that cleaning conditions are consistent with prescribed usage conditions. 	<ol style="list-style-type: none"> The resin material used for the outer coating of capacitors is occasionally a wax substance for moisture resistance which can easily be dissolved by some solutions. So before cleaning, special care should be taken to test the component's vulnerability to the solutions used. When using water-soluble flux please clean the PCB with purified water sufficiently and dry thoroughly at the end of the process. Insufficient washing or drying could lower the reliability of the capacitors.
6. Post-cleaning-process	<p>◆Application of resin molding, etc. to the PCB and components.</p> <ol style="list-style-type: none"> Please contact your local Taiyo Yuden sales office before performing resin coating or molding on mounted capacitors. Please verify on the actual application that the coating process will not adversely affect the component quality. 	<ol style="list-style-type: none"> 1-1. The thermal expansion and coefficient of contraction of the molded resin are not necessarily matched with those of the capacitor. The capacitors may be exposed to stresses due to thermal expansion and contraction during and after hardening. This may lower the specified characteristics and insulation resistance or cause reduced withstand voltage by cracking the ceramic or separating the coated resin from the ceramics. 1-2. With some types of mold resins, the resin's decomposition gas or reaction gas may remain inside the resin during the hardening period or while left under normal conditions, causing a deterioration of the capacitor's performance. 1-3. Some mold resins may have poor moisture proofing properties. Please verify the contents of the resins before they are applied. 1-4. Please contact Taiyo Yuden before using if the hardening process temperature of the mold resins is higher than the operating temperature of the capacitors.
7. Handling	<p>◆Mechanical considerations</p> <ol style="list-style-type: none"> Be careful not to subject the capacitors to excessive mechanical shocks. Withstanding voltage failure may result. If ceramic capacitors are dropped onto the floor or a hard surface they should not be used. 	<ol style="list-style-type: none"> Because the capacitor is made of ceramic, mechanical shocks applied to the board may damage or crack the capacitors. Ceramic capacitors which are dropped onto the floor or a hard surface may develop defects and have a higher risk of failure over time.
8. Storage conditions	<p>◆Storage</p> <ol style="list-style-type: none"> To maintain the solderability of terminal electrodes and to keep the packaging material in good condition, care must be taken to control temperature and humidity in the storage area. Humidity should especially be kept as low as possible. Recommended conditions: Ambient temperature Below 40 °C Humidity Below 70% RH. Products should be used within 6 months after delivery. After the above period, the solderability should be checked before using the capacitors. Capacitors should not be kept in an environment filled with decomposition gases such as (sulfurous hydrogen, sulfurous acid, chlorine, ammonia, etc.) Capacitors should not be kept in a location where they may be exposed to moisture, condensation or direct sunlight. 	<ol style="list-style-type: none"> Under high temperature/high humidity conditions, the decrease in solderability due to the oxidation of terminal electrodes and deterioration of taping and packaging characteristics may be accelerated.

貫通セラミックコンデンサ(段付形) FEEDTHROUGH CERAMIC CAPACITORS (STEPPED TYPE)

OPERATING TEMP. -25~+85°C



特長 FEATURES

- ・電極がニッケルのため半田くわれやマイグレーションの心配がなく量産性に優れる
- ・Nickel plated electrodes reduce the possibility of corrosion, migration and improve productivity.

用途 APPLICATIONS

- ・チューナ・通信機等の妨害対策として最適・高周波領域におけるノイズ吸収性が優れ、光ディスク関連など各種デジタル機器のEMC対策として有効
- ・Used as an interference countermeasure in tuners and telecommunication equipment
- ・Excellent as a EMC countermeasure in various types of digital equipment due to their noise absorption features in high frequency applications.

形名表記法 ORDERING CODE

G series

1	2	3	4	5
定格電圧 (VDC)	形状	温度特性	公称静電容量 (pF)	容量許容差
U 50	G3 φ2.8 mm 段付形 G1 φ1.85mm 段付形	△Y ± 22% SL +350~-1000ppm/°C △=スペース	例 020 2 102 1,000	D ± 0.5 pF K ± 10 % M ± 20 % V ± $\frac{20}{10}$ % P ± $\frac{100}{0}$ % Z ± 20 %
6	7			
芯線寸法	当社管理記号			
0607 A寸 6.0mm・B寸 7.0mm } } 1714 A寸 17.0mm・B寸 14.0mm	---A 標準品			

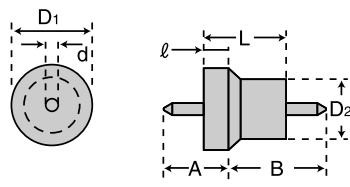

1	2	3	4	5
Rated voltage[VDC]	Shape	Temperature characteristics	Nominal capacitance[pF]	Capacitance Tolerances
U 50	G3 φ2.8mm G1 φ1.85mm	△Y ± 22% S L +350~-1000ppm/°C △=Blank space	020 2 102 1,000	D ± 0.5 pF K ± 10 % M ± 20 % V ± $\frac{20}{10}$ % P ± $\frac{100}{0}$ % Z ± $\frac{80}{20}$ %
6	7			
Lead Length	Internal code			
0607 A 6.0mm・B 7.0mm } } 1714 A 17.0mm・B 14.0mm	---A Standard product			

		Gシリーズ Series G	
		リード付 Led type	
Fig.			
	Dimensions		
		G1	G3
	D1	1.85 ^{+0.1} _{-0.15} (0.073)	2.8±0.2 (0.110±0.008)
	D2	1.4±0.1 (0.055±0.004)	2.0±0.1 (0.079±0.004)
	d	0.6±0.05 (0.024±0.002)	0.6±0.05 (0.024±0.002)
	L	1.4±0.1 (0.055±0.004)	2.0±0.5 (0.079±0.020)
	ℓ	0.5(参考値) (0.020) (reference)	0.7(参考値) (0.028) (reference)
	A	6.0~17.0(1mmステップ) (0.236~0.669)(0.039 Step)	
	B	7.0~14.0(1mmステップ) (0.276~0.551)(0.039 Step)	

Unit : mm(inch)

バリエーション AVAILABLE CAPACITANCE RANGE

G series

形名 Type	温度特性 Temperature characteristics	公称静電容量 Capacitance [pF]	Q or tan δ	容量許容差 Capacitance tolerance	定格電圧 Rated voltage (DC)	耐電圧 withstanding voltage (DC)
G1	SL	2	Q≥50	± 0.5pF	50V	150V
		10	Q≥100	± 20%		
		33 43 82	Q≥100	± 10%		
Y(Y5S)	1000	tan δ ≤ 5.0%	± 80%	100V		
			± 20%			
			± 10%			
G3	SL	2	Q≥50	± 0.5pF	50V	150V
		22 33 43	Q≥100	± 10%		
		82	± 20%			
	1000	tan δ ≤ 5.0%	± 100%	100V		
	2000		± 80%			

(注)温度特性の()はEIA規格相当表示です。

() Indicates EIA standard.

セレクションガイド
Selection Guide



etc

アイテム一覧
Part Numbers



特性図
Electrical Characteristics



梱包
Packaging



信頼性
Reliability Data



使用上の注意
Precautions



特性図 ELECTRICAL CHARACTERISTICS

インピーダンス—周波数特性例 Impedance - vs - Frequency characteristics

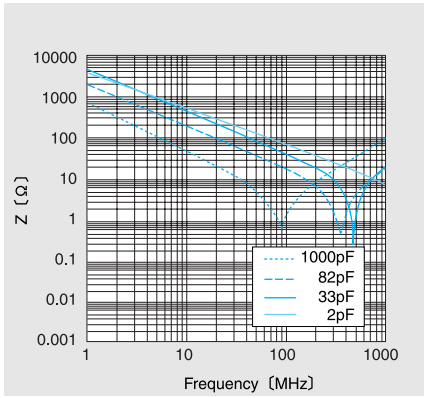

梱包 PACKAGING

最小受注単位数 Minimum Quantity

区分 Category	形式 Type	最小受注単位数 Minimum Quantity(pcs) 袋詰め Bulk
段付 Stepped type	UG1 UG3	1000

FEEDTHROUGH CERAMIC CAPACITORS (STEPPED TYPE)

No.	Item	Specified Value		Test Methods and Remarks
		Stepped feed-through capacitor		
		series G		
		(Class 1)	(Class 3)	
1.	Operating Temperature Range	-25 to +85°C		
2.	Storage Temperature Range	-25 to +85°C		
3.	Rated Voltage	50 VDC		
4.	Withstanding Voltage	Between terminals	No abnormality	According to JIS C 5102 clause 7.1.3. Applied voltage: 125V DC (Class 1) 100V DC (Class 3) Duration: 60±5 sec.
5.	Insulation Resistance	Between terminals	10000MΩ min.	1000MΩ min. Applied voltage: Rated voltage Duration: 60±5 sec. Charge/discharge current shall not exceed 10mA. (Class 3)
6.	Capacitance and Tolerance	2pF : ± 0.5pF 22pF~43pF : ±10% 82pF : ± $\frac{20}{10}$ % ※But series G110pF±20%82pF±10%	1000pF:± $\frac{100}{0}$ % 2000pF:± $\frac{80}{20}$ %	Measuring frequency: 1MHz±20% (Class 1) 1KHz±20% (Class 3) Measuring voltage: 1.0±0.5Vrms Bias application: None
7.	Q or Tangent of Loss Angle (tanδ)	See the attached table.		
8.	Temperature Characteristic of Capacitance, without voltage application	SL: +350 to -1000ppm/°C	Y: ±22%	According to JIS C 5102 clause 7.12. Measurement of capacitance at 20°C and 85°C shall be made to calculate temperature characteristic by the following equation. (Class 1) $\frac{(C_{85} - C_{20})}{C_{20} \times \Delta T} \times 10^6 \text{ (ppm/°C)}$ (Class 2, 3) Change of maximum capacitance deviation in step 1 to 5 Temperature at step 1: 20°C Temperature at step 2: -25°C Temperature at step 3: 20°C (Reference temperature) Temperature at step 4: 85°C Temperature at step 5: 20°C
9.	Terminal Strength	Tensile	No abnormalities, such as cuts or looseness of terminals	Applied force : 10N (Leaded type G series) Duration: 5sec.
		Torsional	No abnormality such as cut lead, or looseness.	Fix the body, incline the terminal end through angle of 45° and return it to initial position. Then second bend in the opposite direction shall be made. Number of bends: 2 times
10.	Resistance to Vibration	Appearance: No significant abnormality Capacitance change: Shall satisfy the initial characteristic.		According to JIS C 5102 clause 8.2. Vibration type: A Directions: 2hrs each in X, Y, and Z directions Total: 6hrs Frequency range: 10 to 55 to 10Hz (1min.) Amplitude: 1.5mm Mounting method: Soldering onto PC board
11.	Solderability	At least 75% of terminal electrode is covered by new solder.		According to JIS C 5102 clause 8.4. Solder temperature: 230±5°C
12.	Damp Heat	Appearance: No significant abnormality Capacitance change: Within ±5.0% or ±0.5pF, whichever is larger. Q: 2pF : 50min. 10pF to 82pF : 75 min.	Appearance: No significant abnormality Capacitance change : Within ±20% tanδ : 7.5%max.	Temperature: 40±2°C Humidity: 90 to 95% RH Duration: 500 ± $\frac{24}{0}$ hrs Recovery: 1hr of recovery under the standard condition after the removal from test chamber.

FEEDTHROUGH CERAMIC CAPACITORS (STEPPED TYPE)

No. Item	Specified Value		Test Methods and Remarks
	Stepped feed-through capacitor		
	series G		
	(Class 1)	(Class 3)	
13. Loading under Damp Heat	Appearance : No significant abnormality Capacitance change : Within $\pm 5.0\%$ or ± 0.5 pF, whichever is the larger. Q : 2pF : 50min. 10pF to 82pF : 75min.	Appearance : No significant abnormality Capacitance change : Within $\pm 20\%$ $\tan\delta$: 7.5% max.	Duration: $500 \pm \frac{24}{0}$ hrs Applied voltage: Rated voltage Recovery: 1 hr of recovery under the standard condition after the removal from test chamber.
14. High Temperature Loading Test	Appearance : No significant abnormality Capacitance change : Within $\pm 5.0\%$ or ± 0.5 pF, whichever is the larger. Q : 2pF : 50 min. 10pF to 82pF : 75 min.	Appearance : No significant abnormality Capacitance change : Within $\pm 20\%$ $\tan\delta$: 7.5% max.	According to JIS C 5102 clause 9.10. Temperature: $85 \pm 2^\circ\text{C}$ Humidity: 90 to 95% RH Duration: $1000 \pm \frac{48}{0}$ hrs Applied voltage: Rated voltage $\times 2$ Recovery: 1 to 2 hrs of recovery under the standard condition after the removal from test chamber. Charge/discharge current shall not exceed 50mA. (Class 1) Charge/discharge current shall not exceed 10mA. (Class 3)

Withstanding voltage is also referred to as "voltage proof" under IEC specifications.

PRECAUTIONS

FEEDTHROUGH CERAMIC CAPACITORS (STEPPED TYPE)

Stages	Precautions	Technical considerations
1. Circuit Design	<ul style="list-style-type: none"> ◆Verification of operating environment, electrical rating and performance 1. A malfunction in medical equipment, spacecraft, nuclear reactors, etc. may cause serious harm to human life or have severe social ramifications. As such, any capacitors to be used in such equipment may require higher safety and/or reliability considerations and should be clearly differentiated from components used in general purpose applications. ◆Operating Environment precautions 1. capacitors should not used in the following environments: <ul style="list-style-type: none"> (1)Environmental conditions to avoid <ul style="list-style-type: none"> a. exposure to water or salt water. b. exposure to moisture or condensation. c. exposure to corrosive gases (such as hydrogen sulfide, sulfuric acid, chlorine, and ammonia) 	