

D SERIES

HIGH VOLTAGE RELAYS 10KV & 15KV

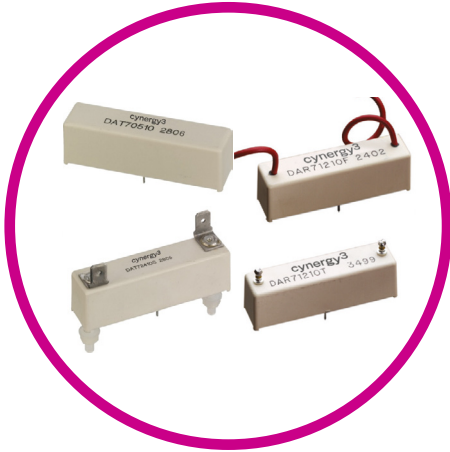

Very high isolation voltages, up to 15kV, are achieved through the use of high vacuum reed switches with either rhodium or tungsten contacts and make these relays suitable for high reliability applications, such as cardiac defibrillators, test equipment and high voltage power supplies.

The rhodium contact relays have low contact resistance, while the tungsten contact relays can switch higher voltages.

PCB or panel mount, via nylon studs, versions are available.

Connection options, for the HV, include PCB, solder turret (wire wrap), flying lead and 0.25" spade terminals.

Features

- 10kV or 15kV Isolation
- Low contact resistance
- PCB or panel mount
- HV connections via flying leads, solder turret (wire wrap), or 1/4" spade terminals
- Excellent AC characteristics

SPECIFICATIONS

Contact	Units	Condition	10kV SPNO		10kV SPNC		15kV SPNO
			Rhodium	Tungsten	Rhodium	Tungsten	Tungsten
Contact Material			Rhodium	Tungsten	Rhodium	Tungsten	Tungsten
Isolation Across Contacts	kV	DC or AC peak	10	10	10	10	15
Switching Power Max.	W		50	50	50	50	50
Switching Voltage Max.	V	DC or AC peak	1000	7000	1000	7000	10000
Switching Current Max.	A	DC or AC peak	3	2	3	2	2
Carry Current Max	A	DC or AC peak	4	3	4	3	2
Capacitance Across Contacts	pF	coil to screen grounded	<0.2	<0.2	<0.2	<0.2	<0.2
Lifetime	operations	dry switching	10 ⁹	10 ⁹	10 ⁹	10 ⁹	10 ⁹
		50W switching	10 ⁶	10 ⁶	10 ⁶	10 ⁶	10 ⁶
Contact Resistance	mΩ	max (typical)	50 (15)	250 (100)	50 (15)	250 (100)	250 (100)
Insulation Resistance	Ω	min (typical)	10 ¹⁰ (10 ¹³)		10 ¹⁰ (10 ¹³)		10 ¹⁰ (10 ¹³)

Coil	Units	Condition	10kV SPNO			10kV SPNC			15kV SPNO		
			5V	12V	24V	5V	12V	24V	5V	12V	24V
Must Operate Voltage	V	DC	3.7	9	20	3.7	9	20	3.7	9	20
Must Release Voltage	V	DC	0.5	1.25	4	0.5	1.25	4	0.5	1.25	4
Operate Time	ms	diode fitted	3.0	3.0	3.0	2.0	2.0	2.0	3.0	3.0	3.0
Release Time	ms	diode fitted	2.0	2.0	2.0	3.0	3.0	3.0	2.0	2.0	2.0
Resistance	Ω		28	150	780	38	240	925	16	95	350

Note. The operate / release voltage and coil resistance will change at a rate of 0.4% per degree C. Values are stated at room temperature (20 degrees C)

Relay					
Isolation Contact/Coil	kV	DC or AC peak	17		17
Insulation Resistance Contact to all Terminals	Ω	min (typical)	10 ¹⁰ (10 ¹³)		10 ¹⁰ (10 ¹³)
Environmental Conditions					
Operating Temp Range	°C		-20 to +70		-20 to +70

Please refer to this document for circuit design notes:
<https://www.cynergy3.com/blog/reed-relay-application-notes>

DIMENSIONS

All dimensions are in millimeters.

STANDARD

(e.g. DAT71210)

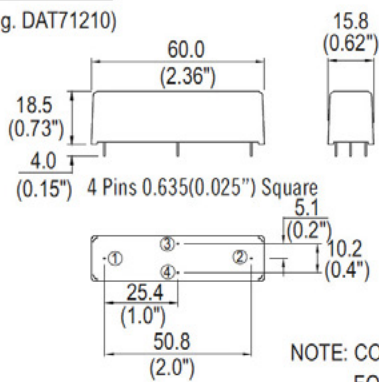

CIRCUIT DIAGRAMS (ALL VARIANTS)

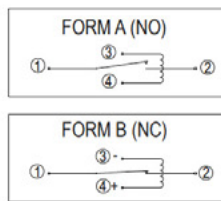

NOTE: COIL POLARITY IS IMPORTANT FOR FORM B VARIANT ONLY.

FLYING LEAD

(e.g. DAT71210F)

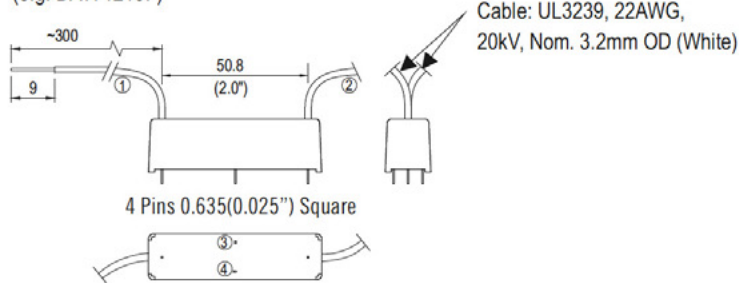

NOTE: PINS WHICH ARE NOT NUMBERED HAVE NO ELECTRICAL CONNECTION.

PANEL MOUNT

(e.g. DAT71210P)

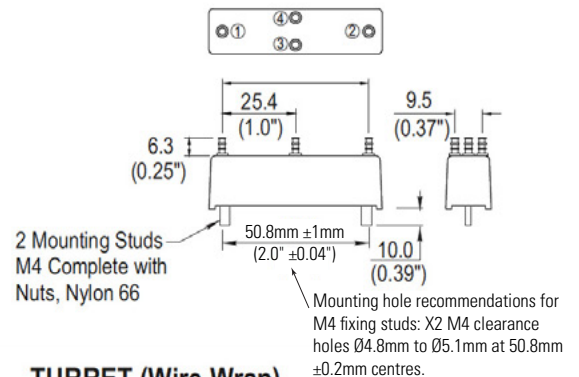

TURRET (Wire Wrap)

(e.g. DAT71210T)

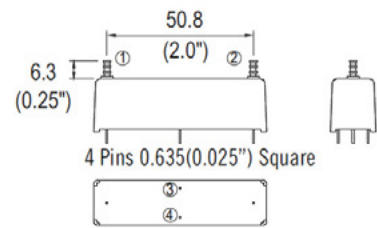

NOTE: PINS WHICH ARE NOT NUMBERED HAVE NO ELECTRICAL CONNECTION.

SPADE TYPE

(e.g. DAT71210S)

'S' Suffix denotes the 0.250" 'Push On' blade connectors, M4 fixing bolts and Epoxy potting.

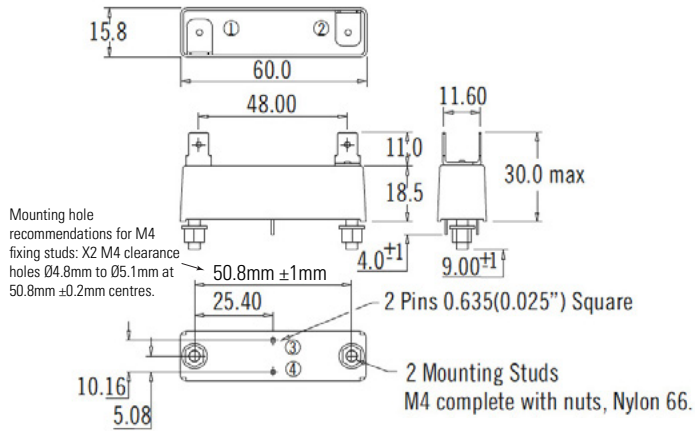

Please refer to this document for circuit design notes:

<https://www.cynergy3.com/blog/reed-relay-application-notes>

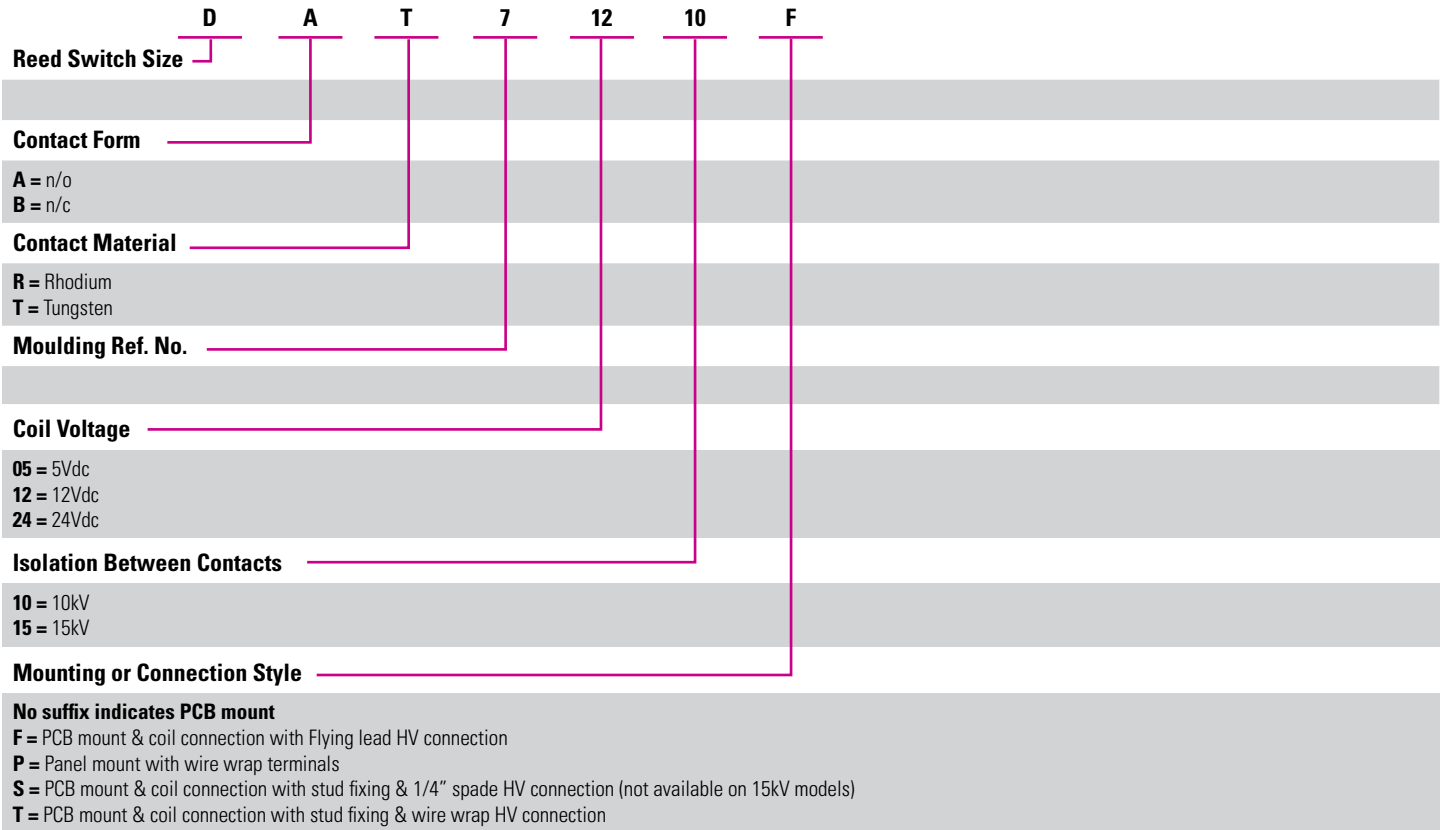

Datasheets provided by Sensata Technologies, Inc., its subsidiaries and/or affiliates ("Sensata") are solely intended to assist third parties ("Buyers") who are developing systems that incorporate Sensata products (also referred to herein as "components"). Buyer understands and agrees that Buyer remains responsible for using its independent analysis, valuation, and judgment in designing Buyer's systems and products. Sensata datasheets have been created using standard laboratory conditions and engineering practices. Sensata has not conducted any testing other than that specifically described in the published documentation for a particular datasheet. Sensata may make corrections, enhancements, improvements, and other changes to its datasheets or components without notice. Buyers are authorized to use Sensata datasheets with the Sensata component(s) identified in each particular datasheet. HOWEVER, NO OTHER LICENSE, EXPRESS OR IMPLIED, BY ESTOPPEL OR OTHERWISE TO ANY OTHER SENSATA INTELLECTUAL PROPERTY RIGHT, AND NO LICENSE TO ANY THIRD PARTY TECHNOLOGY OR INTELLECTUAL PROPERTY RIGHT, IS GRANTED HEREIN. SENSATA DATASHEETS ARE PROVIDED "AS IS". SENSATA MAKES NO WARRANTIES OR REPRESENTATIONS WITH REGARD TO THE DATASHEETS OR USE OF THE DATASHEETS, EXPRESS, IMPLIED, OR STATUTORY, INCLUDING ACCURACY OR COMPLETENESS. SENSATA DISCLAIMS ANY WARRANTY OF TITLE AND ANY IMPLIED WARRANTIES OF MERCHANTABILITY, FITNESS FOR A PARTICULAR PURPOSE, QUIET ENJOYMENT, QUIET POSSESSION, AND NON-INFRINGEMENT OF ANY THIRD PARTY INTELLECTUAL PROPERTY RIGHTS WITH REGARD TO SENSATA DATASHEETS OR USE THEREOF.

All products are sold subject to Sensata's terms and conditions of sale supplied at www.sensata.com. SENSATA ASSUMES NO LIABILITY FOR APPLICATIONS ASSISTANCE OR THE DESIGN OF BUYERS' PRODUCTS. BUYER ACKNOWLEDGES AND AGREES THAT IT IS SOLELY RESPONSIBLE FOR COMPLIANCE WITH ALL LEGAL, REGULATORY, AND SAFETY-RELATED REQUIREMENTS CONCERNING ITS PRODUCTS, AND ANY USE OF SENSATA COMPONENTS IN ITS APPLICATIONS, NOTWITHSTANDING ANY APPLICATIONS- RELATED INFORMATION OR SUPPORT THAT MAY BE PROVIDED BY SENSATA.

Mailing Address: Sensata Technologies, Inc., 529 Pleasant Street, Attleboro, MA 02703, USA

CONTACT US

Sensata Technologies
 Jan Tinbergenstraat 80
 7559 SP Hengelo
 The Netherlands
 1-508-236-3800
 +44 (0)1202 897969
cynergy3.enquiries@sensata.com