



OPS3

Oil Property Sensor

The OPS3 is an Oil Property Sensor (OPS) that directly and simultaneously measures the dynamic viscosity, density, dielectric constant, resistance (Rp) and temperature of oils. Relying on patented tuning fork technology, the sensor monitors multiple physical properties that enables the system to determine the quality, condition and contaminant loading of fluids such as engine oil, transmission, hydraulic and gear oils. The multi-parametric analysis capability improves fluid characterization algorithms. The OPS3 provides in-line and continuous monitoring of fluids for a wide range of OEM and aftermarket installations including process lines and pressurized high flow conduits (e.g., engine oil gallery). Applications include on and off highway vehicles, compressors, industrial equipment and turbines. A universal digital CAN J1939 based protocol provides easy to connect interface to main Host controller. A simple four pins connector allows for cost effective mounting options.

Continuous monitoring of oil condition enabled by OPS3 solves several problems encountered by users:

- Decrease total cost of ownership (TCO) by extending oil change intervals, diminishing machine downtime and reducing oil waste
- Mitigating failure risk by sensing unexpected oil degradation

Features

- Rugged construction for high pressure and high flow environments
- On-board microprocessor for real-time data analysis with 12-24 volts supply
- Highly reliable and long-term stability

Applications

- Engine, transmission, gearbox and hydraulic oils for On and Off-highway vehicles
- Hydraulic Systems
- Compressors

CLICK HERE ›
CONNECT WITH A SPECIALIST

Ordering Information

Description	TE Part Number
OPS3 C4-A 12/24V	10131380-00
OPS3 C4-B 12/24V	10131380-01
OPS3 C4-C 12/24V	10131380-02
OPS3 C4-D 12/24V	10131380-03
OPS3 C4-A 12/24V – 500k	10131380-05
OPS3 C4-A 12/24V – No Rp	10131380-06

Performances Specifications

Maximum Ratings	Value
Supply voltage	9 to 60 Vdc
Typical Current Consumption (at room temperature)	@12V: 71mA @24V: 41mA
Inrush current @12V (note)	2A ATO or mini-fuse
Operating temperature (electronics)	-40 to +125°C
Operating temperature (oil)	-40 to +150°C
Storage Temperature	-50 to +150°C
Maximum Operating Pressure	25 Bar

(Note): Inrush current depends on the installation. Please contact TE for more information.

Measurement Characteristics

For Vcc from 9 to 36V, T=100°C, for a Cannon Instrument S60 oil, unless otherwise noted. TE Connectivity recommends testing these performances when the sensor is installed in the actual application. Please refer to the Installation guideline.

Multi-parametric measurement ranges	Symbol	Range		Unit	Errors	Unit
Dynamic Viscosity	μ	0.5	50	mPa-s (cP)	+/- 5 for μ > 10 cP	% value
					+/- 0.5 for μ ≤ 10 cP	cP
Density	ρ	0.65	1.5	g/cm ³	+/- 3	% value
Dielectric constant	ε	1	6		+/- 3	% value
Rp	Rp	1.0 E+06	1.0 E+08	Ω	+/- 5*	% value
Fluid temperature	T	-40	150	°C	+/- 2	°C

Note: Given errors are valid only under the condition that all fluid parameters are within the given ranges at the same time.

*: As Rp measurement is dependent on OPS3 design, the +/-5% is the variation range expected in Cannon S60 oil at 100°C.

Communication

Protocol	OPS3 supports CAN as per SAE J1939 standard
Outputs	Sensor broadcasts 4 frames on the CAN bus. Please refer to installation guideline for further details.
Commanded address	Enables multi sensor on single CAN bus, as per SAE J1939-81
Refresh rate	Every 30 seconds
Baudrates	250 kbps / 500kbps
Self-Diagnostics	Enables quick troubleshooting in field
CAN Services	Address Claim; ECU ID; Component ID; Software ID; DM11; DM19

Mechanical Integration

Dimensions

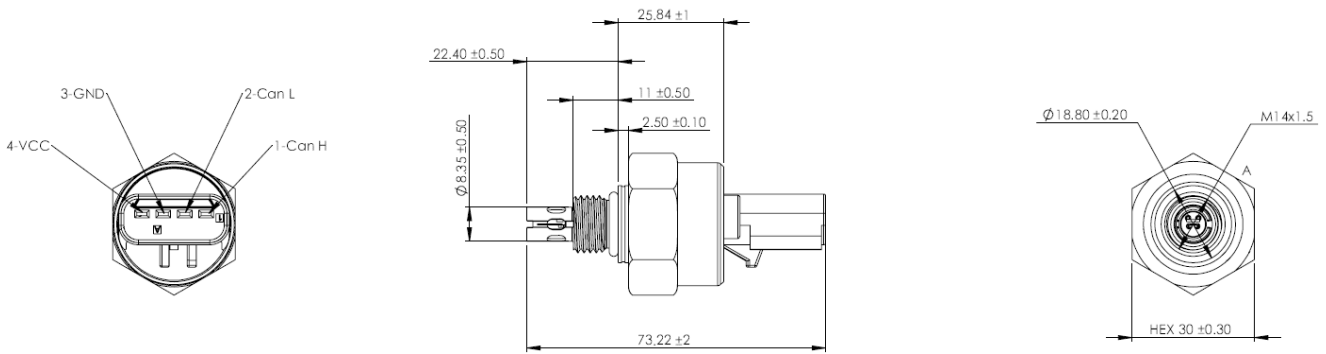

Material	Stainless Steel 316L
Connector	<p>Connector is based on Aptiv references: 33503579 (Key-A) / 13545750 (Key-B) / 33503580 (Key-C) / 33503581 (Key-D)</p> <p>Mating connector Aptiv references: 15425692 (Key-A) / 15324787 (Key-B) / 13854439 (Key-C) / 13755420 (Key-D)</p> <p>Mating connector terminals Aptiv references: 10810733, 13627267, 1010375 depending on wire gauge, and other APEX2.8 series female contacts if alternate plating is preferred</p> <p>OPS3 Connector Material: LCP</p>
Weight	63g
Threaded port	M14x1.5 (SAE J2244)
Torque	27Nm ±20% < 80rpm



Standards and Certifications

Sealing	IP6K9K when connected as per ISO 20653
Mechanical	Salt Atmosphere as per IEC/EN 60068-2-11 Thermal Shocks as per IEC/EN 60068-2-14 Random Vibration as per IEC/EN 60068-2-64
Electrical	ISO 7637-2 Pulses 1, 2a, 2b, 3a, 3b ISO 16750-2 Pulse 4; Load Dump 5a, 5b Insulation Resistance >10MΩ @500VDC between Stainless Steel body and connectors pins Protected against usual automotive power supply transients (overvoltage, miswiring, etc)
EMC	Conducted Emissions as per IEC 60533 Radiated Emissions as per ISO14270 ESD as per IEC/EN 61000-4-2 Radiated Immunity as per IEC/EN 61000-4-3 RF Injection as per IEC/EN 61000-4-6 Magnetic Field Immunity as per IEC/EN 61000-4-8 Bulk Current Injection as per ISO 11452-4
Certifications	RoHS compliant REACH compliant

[CLICK HERE >](#)
CONNECT WITH A SPECIALIST

NORTH AMERICA
Tel +1 800 522 6752

EUROPE
Tel +31 73 624 6999

ASIA
Tel +86 0400 820 6015

te.com/sensors

TE Connectivity, TE, TE Connectivity (logo) and Every Connection Counts are trademarks. All other logos, products and/or company names referred to herein might be trademarks of their respective owners

The information given herein, including drawings, illustrations and schematics which are intended for illustration purposes only, is believed to be reliable. However, TE Connectivity makes no warranties as to its accuracy or completeness and disclaims any liability in connection with its use. TE Connectivity's obligations shall only be as set forth in TE Connectivity's Standard Terms and Conditions of Sale for this product and in no case will TE Connectivity be liable for any incidental, indirect or consequential damages arising out of the sale, resale, use or misuse of the product. Users of TE Connectivity products should make their own evaluation to determine the suitability of each such product for the specific application.

© 2021 TE Connectivity Corporation. All Rights Reserved.

Version B 06/2023