

HDE-20 Basic Shielding Hardware Kits

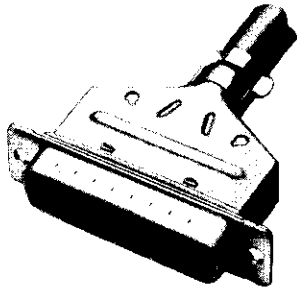

Each kit contains:

- Connector
- Inner shield
- Outer shield

Ferrules must be purchased separately.

Material and Finish:

Connector Shell—Steel, tin plated

Connector Insert—94V-0 rated thermoplastic, black

Shield—Steel, tin plated

Contacts—Phosphor bronze

Contact Finish—Duplex plated:

A—000030 [0.00076] gold on mating end, tin-lead on termination end, with entire contact nickel underplated

B—Gold flash on mating end, tin-lead on termination end, with entire contact nickel underplated

Related Product Data:

Contact Arrangements—page 41

Performance Characteristics—page 42

Application Tooling—pages 126-128

Mateable Connectors:

HDP—pages 95-102

HD-20 Board Mount—pages 55-72, 83-90, 92-94

Mating Hardware—pages 151-155, 158, 160

Mating/Panel Mounting—page 43

Plug

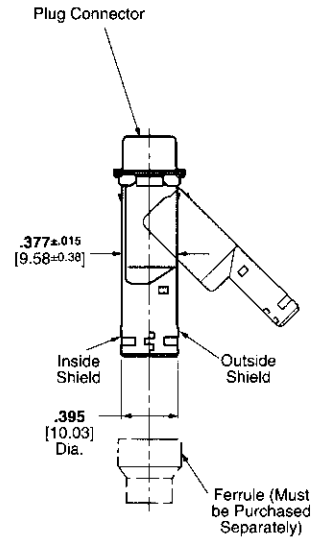
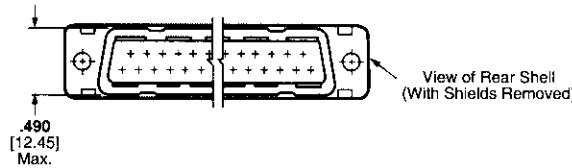
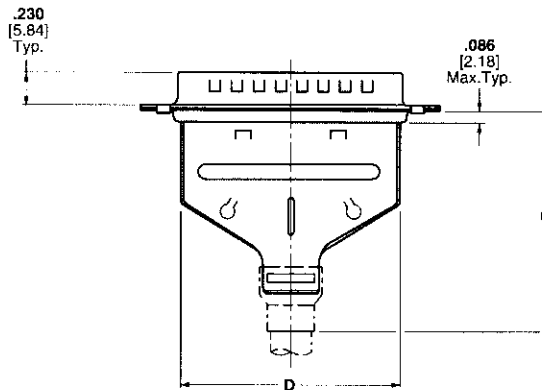
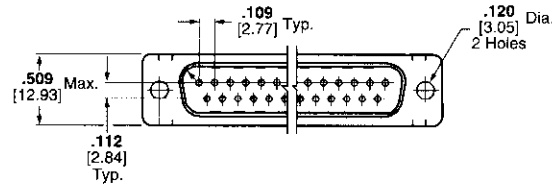

Technical Documents:

Product Specifications—

108-40011

108-40030

Application Specifications—

114-40002

114-40003

114-40006

Instruction Sheet—408-9010

Note: Instruction Sheets for AMP Tooling are packaged with the tooling. For additional information call the Tooling Assistance Center: **1-800-722-1111.**

Shell Size	No. of Contact Pos.	Dimensions		Recommended Cable Outer Dia. Range	Max. Inner Cable Bundle Dia.†	Contact Finish (Plating Code)	Connector Part Numbers		
		C	D				Contact I.D. No. 1 for 30-26 AWG [0.05-0.15mm ²] Wire	Contact I.D. No. 2 for 26-22 AWG [0.15-0.4mm ²] Wire	Contact I.D. No. 3 for 22-20 AWG [0.4-0.6mm ²] Wire
							Plug	Plug	Plug
1	9	1.520 38.61	.678 17.22	.165-.455 4.19-11.56	.350 8.89	A	—	747515-2	747515-3
2	15	1.520 38.61	1.002 25.45	.165-.455 4.19-11.56	.350 8.89	A	747531-1	747531-2	—
						B	—	747531-5	—
3	25	1.520 38.61	1.550 39.37	.165-.455 4.19-11.56	.350 8.89	A	747547-1	747547-2	—
						B	—	747547-5	—
4	37	1.867 47.42	2.205 56.01	.338-.562 8.59-14.28	.450 11.43	A	747563-1	—	—
						B	—	747563-5	—

Note: Components of the kits are shipped unassembled and bulk-packaged in quantities of 100 pieces. †Maximum cable diameter after jacket and braid removed.

Cable Connectors