

# Datasheet

BL5340

*Version 2.1*

---

## Revision History

Version	Date	Notes	Contributor(s)	Approver
1.0	19 Aug 2021	Final updates for production release	Raj Khatri	Jonathan Kaye
1.1	14 Oct 2021	Update Table 45 (removed unnecessary row)	Raj Khatri	Jonathan Kaye
1.2	23 Dec 2021	Updated <b>Mechanical Details</b>	Dave Drogowski	Andrew Chen
1.3	10 Jan 2022	Updated <b>Other Internal Clocks</b>	Raj Khatri	Dave Drogowski
1.4	16 Aug 2023	Updated <b>Tape and Reel Package Information</b> section	Robert Gosewehr	Dave Drogowski
1.5	22 Apr 2024	Fixed typo	Dave Drogowski	Joe Vattimo
1.6	1 Nov 2024	Updated <b>Bluetooth SIG Qualification</b>	Dave Drogowski	Jonathan Kaye
2.0	23 Jan 2025	Ezurio rebranding	Sue White	Dave Drogowski
2.1	4 June 2025	Updated <b>Bluetooth SIG Qualification</b>	Dave Drogowski	Jonathan Kaye

# Contents

1	Overview and Key Features .....	6
1.1	Features and Benefits .....	6
1.2	Application Areas .....	6
2	Specification .....	7
2.1	Specification Summary .....	7
3	Hardware Specifications .....	12
3.1	Block Diagram and Pin-out .....	12
3.2	Pin Definitions .....	14
3.3	Electrical Specifications .....	17
3.3.1	Absolute Maximum Ratings .....	17
3.3.2	Recommended Operating Parameters .....	18
3.4	Application Core and Network Core .....	20
3.5	Clocks .....	21
3.5.1	HFXO - 32MHz crystal oscillator and nRF53 internal load capacitor 13.5pF mandatory setting .....	21
3.5.2	LFCLK - Low Frequency clock source .....	21
3.5.3	Other Internal Clocks .....	24
3.6	BL5340 Power Supply Options .....	24
3.6.1	Normal Voltage mode (option1) or High Voltage mode (option2) .....	25
3.6.2	VBUS pin and 4.7uF Mandatory Capacitor .....	28
3.6.3	VREQCTRL - Voltage request control (VREQCTRL ON for +3dB extra RF TX power) .....	28
3.6.4	Low Power Modes .....	28
3.7	Programmability .....	29
3.7.1	BL5340 Firmware options .....	29
4	Power Consumption .....	30
5	Peripherals .....	31
5.1	RADIO - 2.4GHz radio (RF) .....	31
5.2	NFC Tag - Near field communication tag .....	32
5.2.1	Use Cases .....	32
5.2.2	NFC Antenna Coil Tuning Capacitors .....	33
5.3	UARTE - Universal asynchronous receiver/transmitter with Easy DMA .....	33
5.4	USB D - Universal Serial Bus device .....	35
5.5	SPI Master - Serial Peripheral Interface master .....	35
5.6	SPI Slave - Serial Peripheral Interface slave .....	35
5.7	QSPI - Quad Serial Peripheral interface .....	36
5.8	TWIM - I2C compatible 2-wire interface master .....	36
5.9	TWIS - I2C compatible 2-wire interface master .....	37
5.10	GPIO - General Purpose Input /Output .....	37
5.11	SAADC - Successive approximation analog-to-digital convertor .....	37

5.12	COMP – Comparator .....	38
5.13	LPCOMP – Low power comparator .....	39
5.14	PWM – Pulse Width Modulation.....	39
5.15	TIMER – Timer/counter .....	39
5.16	RTC – Real Timer Counter.....	40
5.17	TEMP – Temperature sensor.....	40
5.18	Security/Privacy.....	40
5.19	RNG – Random number generator .....	40
5.20	I2S – Inter-IC sound interface.....	40
5.21	PDM – Pulse Density Modulation interface and digital microphones .....	42
5.22	QDEC – Quadrature decoder.....	42
5.23	nRESET – pin reset.....	43
5.24	SWD – Two-wire interface.....	43
5.25	Peripheral Block Current Consumption .....	44
5.26	453-00052 On-Board PCB Trace Antenna Characteristics.....	48
6	Mandatory SW requirements related to hardware.....	49
6.1	32MHz crystal internal load capacitor setting of 13.5pF .....	49
6.2	CH26 (2480MHz) IEEE 802.15.4-2006 RF TX power .....	49
7	Hardware Integration Suggestions.....	49
7.1	Circuit .....	49
7.2	PCB Layout on Host PCB - General.....	51
7.3	PCB Layout on Host PCB for the 453-00052.....	52
7.3.1	Antenna Keep-out on Host PCB.....	52
7.3.2	Antenna Keep-out and Proximity to Metal or Plastic .....	53
7.4	50-Ohms RF Trace and RF Match Series 2nH RF inductor on Host PCB for BL5340 RF pad variant (453-00053) .....	53
7.5	External Antenna Integration with the 453-00052.....	56
8	Mechanical Details .....	57
8.1	BL5340 Mechanical Details .....	57
8.2	Host PCB Land Pattern and Antenna Keep-out for the 453-00052 .....	58
9	Application Note for Surface Mount Modules .....	59
9.1	Introduction .....	59
9.2	Shipping.....	59
9.2.1	Tape and Reel Package Information.....	59
9.2.2	Carton Contents and Packaging Process .....	61
9.2.3	Module Orientation in Cavity .....	61
9.2.4	Labeling .....	62
9.3	Reflow Parameters .....	62
10	Regulatory .....	65
11	Ordering Information .....	65

12	Bluetooth SIG Qualification .....	66
12.1	Overview .....	66
12.2	Scope .....	66
12.3	Qualification Steps When Referencing multiple existing designs, (unmodified) – Option 2a in the QPRDv3 .....	66
12.4	Example Design Combinations .....	68
12.5	Qualify More Products .....	68
13	Reliability Tests .....	69
14	Additional Information .....	70

# 1 Overview and Key Features

The BL5340 series of robust, tiny modules feature the Nordic nRF5340 SoC. It directly targets the highest performance with the lowest power budget, with additional variants featuring integrated Nordic nRF21540 PA/LNA for higher TX Power applications. Featuring Bluetooth 5.2 including Isochronous Channels and LE Audio, the BL5340 supports next generation Bluetooth audio for stereo streaming and broadcast audio.



The dual core Arm® Cortex M33 microcontrollers enable you to run a low power core focused purely on wireless connectivity, with a second higher performance core targeted for the end application itself. This further extends the multi-protocol capabilities of the product: Bluetooth LE, 802.15.4 (Thread / Zigbee) and NFC. It's further enhanced with an ARM CryptoCell-312 including trusted execution, root-of-trust and secure key storage security features.

The BL5340 series brings out all nRF5340 hardware features and capabilities including USB access, up to +3 dBm transmit power, from 1.7V to 5.5V supply considerations, and a true industrial operating range of -40 to 105°C. Complete regulatory certifications enable faster time to market and reduced development risk completes Ezurio's simplification of your next multi-protocol wireless design!

**Note:** BL5340 hardware provides all functionality of the nRF5340 chipset used in the module design. This is a hardware datasheet only – it does not cover the software aspects of the BL5340. This is to acknowledge that information in this datasheet is referenced from the nRF5340 datasheet – consult for details: [https://infocenter.nordicsemi.com/topic/ps\\_nrf5340/keyfeatures\\_html5.html?cp=3\\_0\\_0](https://infocenter.nordicsemi.com/topic/ps_nrf5340/keyfeatures_html5.html?cp=3_0_0)

## 1.1 Features and Benefits

- Based on Nordic Semiconductor nRF5340 silicon
- Bluetooth v5.2 – Single mode
- NFC
- IEEE 802.15.4-2006 (Thread or Zigbee) radio support
- External or internal antennas
- Programmable Tx power +3 dBm to -20 dBm, -40 dBm
- Rx sensitivity -98 dBm (1 Mbps), -104 dBm (125 kbps)
- Ultra-low power consumption
- Tx – 5.1 mA peak (at +3 dBm, DCDC on)  
(See **Note 1** in the *Power Consumption* section)
- Rx: 2.7 mA peak (DCDC on)  
(See **Note 1** in the *Power Consumption* section)
- System ON Idle – 1.3 uA typical
- System OFF – 0.9 uA – (See **Note 4** in the *Power Consumption* section)
- UART, GPIO, ADC, PWM, timers, I2C, QSPI, SPI, I2S, PDM, and USB interfaces
- FCC, CE, ISED, RCM, MIC and UKCA certified
- Full Bluetooth Declaration ID
- Other regulatory certifications on request
- No external components required
- Industrial temperature range (-40° C to +105° C)

## 1.2 Application Areas

- Medical devices
- IoT Sensors
- Access Control
- Health & Wellness devices
- Location awareness
- Factory automation

## 2 Specification

### 2.1 Specification Summary

Categories/Feature	Implementation	
<b>Wireless Specification</b>		
Bluetooth®	Bluetooth 5.2 – Single mode <ul style="list-style-type: none"> <li>• Isochronous Channels (LE Audio) – BT 5.2</li> <li>• EATT – BT5.2</li> <li>• LE Power Control – BT 5.2</li> <li>• 4x Range (CODED PHY support) – BT 5.1</li> <li>• 2x Speed (2M PHY support) – BT 5.1</li> <li>• LE Advertising Extension – BT 5.1</li> <li>• Diffie-Hellman based pairing (LE Secure Connections) – BT 4.2</li> <li>• Data Packet Length Extension – BT 4.2</li> <li>• Link Layer Privacy (LE Privacy 1.2) – BT 4.2</li> <li>• Concurrent master, slave</li> <li>• BLE Mesh capabilities</li> <li>• Bluetooth direction finding</li> </ul>	
IEEE 802.15.4-2006 PHY	2405-2480 MHz IEEE 802.15.5-2006 radio transceiver, implementing IEEE 802.15.5-2006 compliant <ul style="list-style-type: none"> <li>• 250kbps,2450MHz, O-QPSK PHY</li> <li>• Channels 11-26. Channel 11 2405MHz and CH26 2480MHz.</li> <li>• Clear channel assessment (CCA)</li> <li>• Energy detection (ED) scan</li> <li>• CRC generation</li> </ul>	
Nordic proprietary 1Mbps and 2Mbps modes radio ( <i>not currently certified by Ezurio</i> )	2402-2480 MHz Nordic proprietary 1Mbps and 2Mbps modes radio transceiver <ul style="list-style-type: none"> <li>• 1Mbps nRF proprietary mode (ideal transmitter)</li> <li>• 2Mbps nRF proprietary mode (ideal transmitter)</li> </ul>	
Frequency	2.402 - 2.480 GHz for BLE (CH0 to CH39) 2.405 - 2.480 GHz for IEEE 802.15.4-2006 PHY (CH11 to CH26)	
Raw Data Rates	1 Mbps BLE (over-the-air) 2 Mbps BLE (over-the-air) 125 kbps BLE (over-the-air) 500 kbps BLE (over-the-air) 250 kbps IEEE 802.15.4 802.15.4-2006 (over-the-air) Nordic proprietary 1Mbps and 2Mbps modes (over-the-air)	
Maximum Transmit Power Setting ( <i>See Note 1 in the Module Specification Notes</i> )	+3 dBm	Conducted 453-00052 (Integrated antenna)
	+3 dBm	Conducted 453-00053 (External antenna)
Minimum Transmit Power Setting	-40 dBm, -20 dBm (in 4 dB steps) -16 dBm, -12 dBm, - 8 dBm, - 7 dBm, -6 dBm, -5 dBm, -4 dBm, -3 dBm, -2 dBm, -1 dBm, 0dBm, +1dBm, +2dBm	
Receive Sensitivity (≤37byte packet for BLE)	BLE 1 Mbps (BER=1E-3)	-98 dBm typical
	BLE 2 Mbps	-92 dBm typical
	BLE 125 kbps	-104 dBm typical
	BLE 500 kbps	-99 dBm typical
	IEEE 802.15.4-2006 250kbps	-101 dBm typical

Categories/Feature	Implementation	
Link Budget (conducted)	101 dB	@ BLE 1 Mbps
	107 dB	@ BLE 125 kbps
<b>NFC</b>		
NFC-A Listen mode compliant	<b>Based on NFC forum specification</b> <ul style="list-style-type: none"> <li>13.56 MHz</li> <li>Date rate 106 kbps</li> <li>NFC Type2 and Type 4 emulation</li> </ul> <b>Modes of Operation:</b> <ul style="list-style-type: none"> <li>Disable</li> <li>Sense</li> <li>Activated</li> </ul> <b>Use Cases:</b> <ul style="list-style-type: none"> <li>Touch-to-Pair with NFC</li> <li>NFC enabled Out-of-Band Pairing</li> </ul>	
System Wake-On-Field function	Proximity Detection	

Host Interfaces and Peripherals	Applications Core (High Performance)	Network Core (ultra-low power)
Total	48 x multifunction I/O lines	
Two co-processors	Arm Cortex-M33 with DSP, FPU, TrustZone support. 1024kB Flash 512kB RAM 8kB 2-way associative cache 128 and 64MHz clock Uses voltage and clock frequency scaling	Arm Cortex-M33 256kB Flash 64kB RAM 2kB instruction cache 64MHz clock
UART	4 x UART (with CTS, RTS)	1 x UART (with CTS, RTS)
USB	1 x USB 2.0 FS (Full Speed, 12Mbps)	-
GPIO	Up to 48 32 x GPIOs on P0.00 to P0.31 15 x GPIOs on P1.00 to P1.15 With configurable I/O direction, O/P drive strength (standard 0.5 mA or high 3mA/5 mA), Pull-up /pull-down Input buffer disconnect	
ADC (200kbps)	Eight 8/10/12-bit channels on AIN0-AIN7 or VDD or VDDH/5 14-bit resolution with oversampling AIN0-AIN7 Configurable reference internal reference 0.6V or external reference VDD/4 Configurable pre-scaling of 4, 2, 1, 1/2, 1/3, 1/4, 1/5 1/6 Configurable acquisition time 3uS, 5uS, 10uS (default), 15uS, 20uS, 40uS. One-shot mode or Burst mode	-

Host Interfaces and Peripherals	Applications Core (High Performance)	Network Core (ultra-low power)
	Scan mode for multiple channels Single ended or Differential or not connected	
COMP	1 x COMP (comparator)	-
LPCOMP	1 x LPCOMP (low power comparator)	-
High-Speed SPI	1 x High-speed SPI (32Mbps, SPIM4) master or slave with Easy DMA on dedicated pins	-
SPI	4 x SPI (upto 16Mbps) master or slave with Easy DMA Slave is upto 8Mbps	1 x SPI master or slave with Easy DMA Slave is upto 8Mbps
High-Speed TWI (I2C)	1 x High-speed TWI (1Mbps) master or slave with Easy DMA on dedicated pins	1 x High-speed TWI (1Mbps) master or slave with Easy DMA on dedicated pins
TWI (I2C)	3 x TWI (upto 400kps, 200kpbs, 100kpbs) master or slave with Easy DMA	1 x TWI (upto 400kps, 200kpbs, 100kpbs) master or slave with Easy DMA
QSPI	1 x QSPI interface (6 to 96MHz configurable clock frequency) for communicating with external flash memory. XIP (Execution in Place) capability.	-
PWM	4 x PWM (pulse width modulation) units with Easy DMA	-
QDEC	2 x QDEC (Quadrature decoder)	-
I2S	1 x I2S (Inter-IC sound interface)	-
PDM	1 x PDM (Pulse code modulation interface) for digital microphones	-
TIMER	3 x Timer (32bit)	3 x Timer (32bit)
RTC	2 x RTC (24bit)	2 x RTC
WDT	2 x WDT (Watchdog timer)	2 x WDT (Watchdog timer)
EGU	6 x EGU (Event generator unit)	1 x EGU (Event generator unit)
RNG	-	1 x RNG (random number generator)
TEMP	-	1 x Temperature sensor Temperature range equal to operating temperature range
ECB	-	1 x ECB (AES electronic codebook mode encryption)
AAR	-	1 x AAR (Accelerated address resolver)
CCM	-	1 x CCM (AES CCM mode encryption)
RSSI	-	1 x RSSI (Received Signal Strength Detector), 1dB resolution. ±2 dB accuracy (valid over -90 to -20 dBm)

**Optional (External to the BL5340 module)**

External optional 32.768 kHz crystal	Not needed for normal radio operation. Optionally, connect +/-20ppm accuracy crystal for more accurate protocol timing. Fit associated load capacitor for crystal or use nRF53 internal load capacitor, which is configurable as either 6pF, 7pF or 9pF on pins XL1, XL2.
--------------------------------------	--

**Programmability**

Zephyr RTOS	Via SWD (JTAG) 2 wire interface
Nordic nRFConnect	Via SWD (JTAG) 2 wire interface

**Supply Voltage**

VDD	Normal voltage mode VDD 1.7- 3.6 V – Internal DCDC converter or LDO OR
VDD_HV	High voltage mode VDD_HV 2.5V-5.5V Internal DCDC converter or LDO

**Power Consumption**

Active Modes Peak Current (for maximum Tx power +3 dBm) – Radio only	5.1 mA peak Tx (with DCDC)
Active Modes Peak Current (for Tx power -40 dBm) – Radio only	2.6 mA peak Tx (with DCDC)
Active Modes Average Current	Depends on many factors, see section <a href="#">Power Consumption</a>
Ultra-low Power Modes	System ON Idle      1.3 uA (wake on any event) System OFF            0.9 uA (wake on reset)

**Antenna Options**

Internal	Printed PCB monopole antenna – on-board ( <b>453-00052 variant</b> )
External	<ul style="list-style-type: none"> <li>Dipole antenna (with IPEX MHF4 connector)</li> <li>Dipole PCB antenna (with IPEX MHF4 connector)</li> <li>Connection via <i>off module</i> IPEX MH4 – <b>453-00053 variant (RF trace pin)</b></li> </ul> <p>See the <a href="#">Regulatory</a> section and <a href="#">Regulatory Information Guide</a> for FCC, ISSED, MIC, RCM, UKCA and CE.</p> <p>The certified list of external antennas is listed in <a href="#">External Antenna Integration with the 453-00052</a> section.</p>

**Physical**

Dimensions	15.0 mm x 10 mm x 2.0 mm Pad Pitch – 0.8 mm Pad Type – Three rows of pads (LGA - Land Grid Array).
Weight	<1 gram

**Environmental**

Operating	-40 °C to +105 °C
Storage	-40 °C to +105 °C

**Miscellaneous**

Lead Free	Lead-free and RoHS compliant
Warranty	One-Year Warranty

**Development Tools**

Development Kit	Development kit per module SKU (453-00052-K1 and 453-00053-K1 respectively)
-----------------	---

**Approvals**

**Optional (External to the BL5340 module)**

Bluetooth®	Full Bluetooth SIG Declaration ID
FCC/ISED/CE/MIC/RCM/UKCA	All BL5340 Series

**Module Specification Notes:**

**Note 1** **MANDATORY.** When used in IEEE 802.15.4-2006 PHY mode, channel 26 (2480MHz), the BL5340 RF TX power must be limited by customer to -8 dBm setting (which produces -5dBm with VREQCTRL ON) maximum RF transmit power to pass FCC/IC Band Edge emissions limit. All other 802.15.4 channels (11-25) may be used up to the maximum 0dBm (which produces +3 dBm with VREQCTRL ON) RF TX output power.

**Note 2** VREQCTRL must be set ON to produce extra +3dB of RF TX power at each nRF5340 RF TX power setting.

nRF5340 RF TX power setting	Register VREQCTRL OFF Actual nRF5340 RF TX power	Register VREQCTRL ON (to add extra +3dB) Actual nRF5340 RF TX power
0 dBm	0 dBm	+3 dBm (= 0 dBm +3 dB)
-1 dBm	-1 dBm	+2 dBm (= -1 dBm +3 dB)
-2 dBm	-2 dBm	+1 dBm (= -2 dBm +3 dB)
-3 dBm	-3 dBm	0 dBm (= -3 dBm +3 dB)
-4 dBm	-4 dBm	-1 dBm (= -4 dBm +3 dB)
-5 dBm	-5 dBm	-2 dBm (= -5 dBm +3 dB)
-6 dBm	-6 dBm	-3 dBm (= -6 dBm +3 dB)
-7 dBm	-7 dBm	-4 dBm (= -7 dBm +3 dB)
-8 dBm	-8 dBm	-5 dBm (= -8 dBm +3 dB)
-12 dBm	-12 dBm	-9 dBm (= -12 dBm +3 dB)
-16 dBm	-16 dBm	-13 dBm (= -16 dBm +3 dB)
-20 dBm	-20 dBm	-17 dBm (= -20 dBm +3 dB)
-40 dBm	-40 dBm	-37 dBm (= -40 dBm +3 dB)

### 3 Hardware Specifications

#### 3.1 Block Diagram and Pin-out

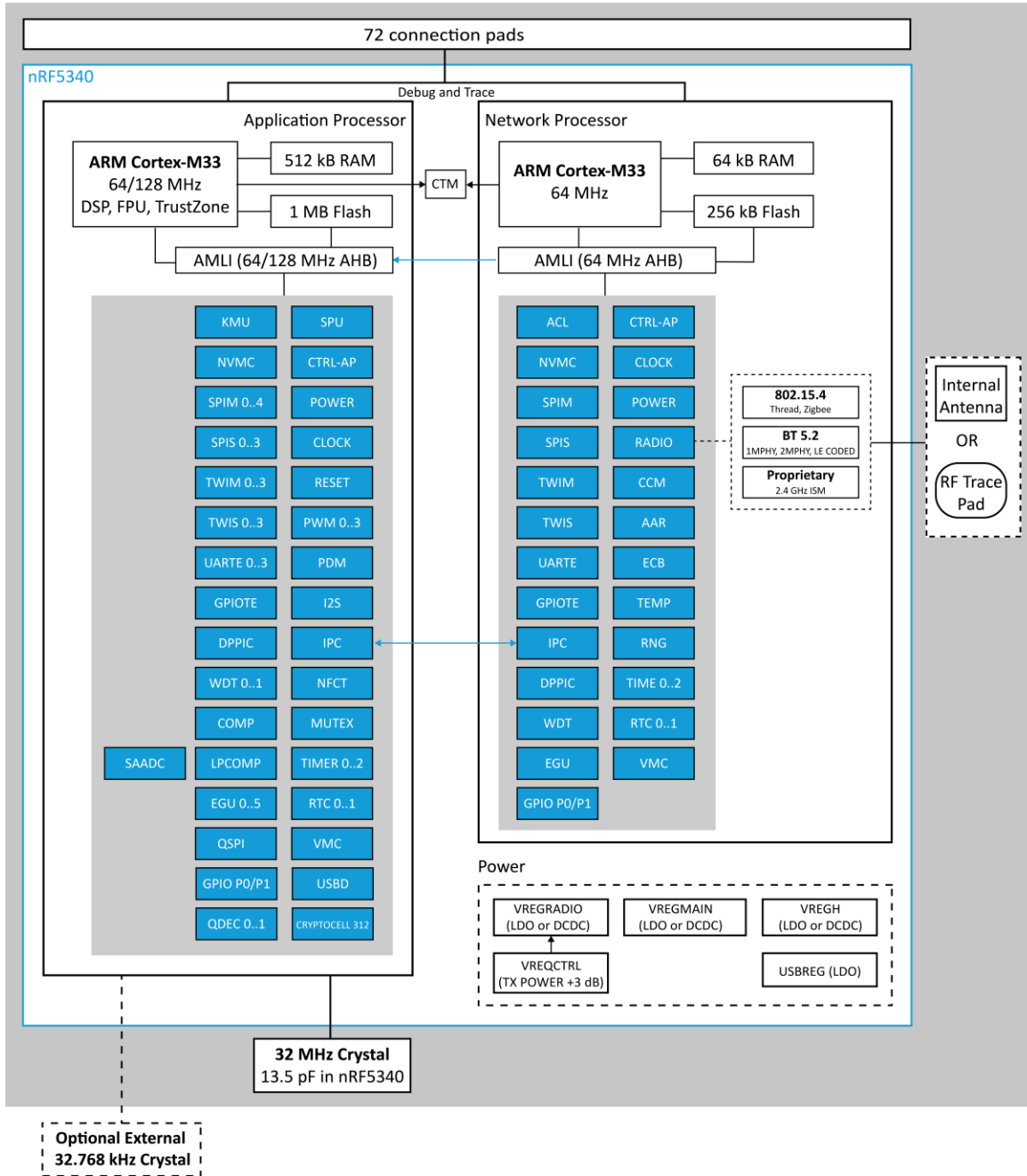

Figure 1: BL5340 HW block diagram



## 3.2 Pin Definitions

**Table 1: Pin definitions**

Pin #	Pin Name	nRF5340 QFN Pin	nRF5340 QFN Name	Comment
1	GND	-	VSS	-
2	P0.26 / AIN5	AL29	P0.26 / AIN5	Dedicated pin for ADC Ezurio Devkit: Ethernet chip SPI_MISO
3	P0.24	AL27	P0.24	Ezurio Devkit: INT2_ACC interrupt from 3-axis accelerometer chip
4	P0.27 / AIN6	AK30	P0.27 / AIN6	Dedicated pin for ADC Ezurio Devkit: Ethernet chip SPI_MOSI
5	P1.09	AK26	P1.09	Ezurio Devkit: UART1_CTS
6	P0.25 / AIN4	AK28	P0.25 / AIN4	Dedicated pin for ADC Ezurio Devkit: Ethernet chip SPI_CS
7	P1.08	AL23	P1.08	Ezurio Devkit: UART1_TX
8	P1.07	AK24	P1.07	Ezurio Devkit: UART1_RTS
9	P1.06	AL21	P1.06	Ezurio Devkit: Interrupt from Port Expander chip PE_INT
10	P1.05	AK22	P1.05	See Note 6
11	P0.21	AL15	P0.21	Ezurio Devkit: UART0_CTS
12	P0.22	AK18	P0.22	Ezurio Devkit: UART0_RX
13	P1.04	AL19	P1.04	See Note 6
14	P0.20	AK16	P0.20	Ezurio Devkit: UART0_TX
15	P0.19	AL13	P0.19	Ezurio Devkit: UART0_RTS
16	P0.17 / QSPI_CLK	AK12	P0.17 / QSPI_CLK	Dedicated pin for QSPI Ezurio Devkit: QSPI flash chip
17	P0.16 / QSPI_IO3	AL9	P0.16 / QSPI_IO3	Dedicated pin for QSPI Ezurio Devkit: QSPI flash chip
18	P0.15 / QSPI_IO2	AK10	P0.15 / QSPI_IO2	Dedicated pin for QSPI Ezurio Devkit: QSPI flash chip
19	GND	-	VSS	-
20	P0.12 / TRACECLK / SPIM4_DCX	AK6	P0.12 / TRACECLK / SPIM4_DCX	Dedicated pin for High-speed SPI (SPIM4, 32Mbps) and Trace Ezurio Devkit: LCD assembly SPIM4_DCX
21	GND	-	VSS	-
22	P0.10 / TRACEDATA1 / SPIM4_MISO	AK2	P0.10 / TRACEDATA1 / SPIM4_MISO	Dedicated pin for High-speed SPI (SPIM4, 32Mbps) and Trace Ezurio Devkit: LCD assembly SPIM4_SPI_MISO
23	P0.11 / TRACEDATA0 / SPIM4_CSN	AK4	P0.11 / TRACEDATA0 / SPIM4_CSN	Dedicated pin for High-speed SPI (SPIM4, 32Mbps) and Trace. SWO also comes out on P0.11 Ezurio Devkit: LCD assembly SPIM4_CS
24	P0.13 / QSPI_IO0	AL5	P0.13 / QSPI_IO0	Dedicated pin for QSPI Ezurio Devkit: QSPI flash chip
25	P0.09 / TRACEDATA2 / SPIM4_MOSI	AJ1	P0.09 / TRACEDATA2 / SPIM4_MOSI	Dedicated pin for High-speed SPI (SPIM4, 32Mbps) and Trace Ezurio Devkit: LCD assembly SPIM4_MOSI
26	P0.03 / NFC2	AA1	P0.03 / NFC2	Dedicated pin for NFC Ezurio Devkit: NFC Coil flexi-PCB NFC antenna plug into CON2
27	P0.08 / TRACEDATA3 / SPIM4_SCK	AH2	P0.08 / TRACEDATA3 / SPIM4_SCK	Dedicated pin for High-speed SPI (SPIM4, 32Mbps) and Trace Ezurio Devkit: LCD assembly SPIM4_SCL

Pin #	Pin Name	nRF5340 QFN Pin	nRF5340 QFN Name	Comment
28	P0.02 / NFC1	W1	P0.02 / NFC1	Dedicated pin for NFC Ezurio Devkit: NFC Coil flexi-PCB NFC antenna plug into CON2
29	GND	-	VSS	-
30	GND	-	VSS	-
31	VDD	A19, B8, L1	VDD	1.7V to 3.6V See 3.6 BL5340 Power Supply Options
32	P0.01 / XL2	R1	P0.01 / XL2	Dedicated pin for NFC Ezurio Devkit: Optional 32.768kHz crystal pad XL2 and associated 7pF load capacitor inside nRF5340 chipset.
33	GND	-	VSS	-
34	P0.00 / XL1	N1	P0.00 / XL1	Dedicated pin for NFC Ezurio Devkit: Optional 32.768kHz crystal pad XL1 and associated 7pF load capacitor inside nRF5340 chipset.
35	VDD_HV	E1	VDD_HV	2.5V – 5.5V See 3.6 BL5340 Power Supply Options
36	D+	B2	D+	Ezurio Devkit: USB3
37	P1.02 / I2C_SDA	AE1	P1.02 / I2C_SDA	Dedicated pins for High-speed TWI (1Mbps). Ezurio Devkit: Multiple I2C sensors:- 3-axis Accelerometer chip, LCD assembly, RTC chip, Temp/Pres/HMD sensor chip, DAC chip, Eeprom chip, Port Expander (PE) chip which has 4 LED's, 4 BUTTONS connected to PE chip.
38	P1.03 / I2C_SCL	AF2	P1.03 / I2C_SCL	
39	GND	-	VSS	-
40	VBUS	A5	VBUS	4.35V – 5.5V See 3.6 BL5340 Power Supply Options
41	P1.00	M2	P1.00	See Note 6
42	D-	B4	D-	Ezurio Devkit: USB3
43	P1.01	P2	P1.01	See Note 6
44	GND	-	-	-
45	P1.15	B14	P1.15	Ezurio Devkit: SD card DO/DAT0
46	P0.05 / AIN1	Y2	P0.05 / AIN1	Dedicated pin for ADC Ezurio Devkit: LCD assembly LCD_CTP_INT
47	P1.13	A17	P1.13	Ezurio Devkit: SD card DI/CMD
48	P1.14	B16	P1.14	Ezurio Devkit: SD card SCLK/CLK
49	P1.12	B18	P1.12	Ezurio Devkit: SD card CS_SD/DAT3
50	P1.11	B20	P1.11	Ezurio Devkit: BOOT BUTTON (S4)
51	P0.31	B22	P0.31	See Note 6
52	P0.30	B24	P0.30	See Note 6
53	P0.28 / AIN7	AE31	P0.28 / AIN7	Dedicated pin for ADC Ezurio Devkit: Ethernet chip SPI_SCK
54	nRESET	AC31	nRESET	System Reset (Active Low). Internal 13K pull up inside nRF5340.
55	SWDIO	AA31	SWDIO	Pull up resistor (13K) inside nRF5340
56	SWDCLK	W31	SWDCLK	Pull down resistor (13K) inside nRF5340
57	P1.10	R31	P1.10	Ezurio Devkit: UART1_RX
58	P0.29	U31	P0.29	See Note 6

Pin #	Pin Name	nRF5340 QFN Pin	nRF5340 QFN Name	Comment
59	GND	-	VSS	-
60	P0.23	AK20	P0.23	Ezurio Devkit: INT1_ACC interrupt from 3-axis accelerometer
61	P0.18 / QSPI_CSN	AK14	P0.18 / QSPI_CSN	Dedicated pin for QSPI Ezurio Devkit: QSPI flash chip
62	P0.14 / QSPI_IO1	AK8	P0.14 / QSPI_IO1	Dedicated pin for QSPI Ezurio Devkit: QSPI flash chip
63	P0.04 / AIN0	V2	P0.04 / AIN0	Dedicated pin for ADC See Note 6
64	P0.06 / AIN2	AB2	P0.06 / AIN2	Dedicated pin for ADC Ezurio Devkit: LCD assembly LCD_Reset
65	P0.07 / AIN3	AD2	P0.07 / AIN3	Dedicated pin for ADC Ezurio Devkit: Interrupt from Ethernet chip INT_ETH
66	GND	-	VSS	-
67	GND	-	VSS	-
68	GND	-	VSS	-
69	GND	-	VSS	-
70	GND	-	VSS	-
71	GND	-	VSS	-
72	RF_pad or NC	-	-	RF pad active on BL5340 RF pin variant 453-0053. NC on BL5340 Integrated antenna variant 453-0052
73	GND	-	VSS	-
74	GND	-	VSS	-
75	GND	-	VSS	-

**Pin Definition Notes:**

<b>Note 1</b> <b>GPIO</b>	<b>GPIO = General Input or Output (GPIO level voltage tracks VDD pin). AIN = Analog input.</b> If GPIO is selected as an input, ensure the input is not floating (which can cause current consumption to drive with time in low power modes (such as System ON Idle), by selecting the internal pull up or pull down. <b>Must connect all GND pads to host board PCB GND plane.</b>
<b>Note 2</b> <b>QSPI/SPI/TWI/Trace</b>	<b>QSPI, High-Speed SPI (SPIM4) 32 Mbps, TWI 1 Mbps and Trace</b> come on dedicated GPIO pins only. Other lower speed SPI (16 Mbps, 8 Mbps, 4 Mbps, 2 Mbps, 1 Mbps, 500 kbps, 250 kbps, 125 kbps) and TWI (400 kbps, 250 kbps, 100 kbps) can come out on any GPIO pins.
<b>Note 3</b> <b>USB</b>	<b>If using the USB interface</b> , then the BL5340 VBUS pin (pin40) must be connected to external supply within the range 4.35V to 5.5V. When using the BL5340 VBUS pin (pin40), you MUST externally fit a 4.7uF to ground.
<b>Note 4</b> <b>SWDIO / SWCLK / nRESET / VDD / GND</b>	<b>Customer MUST bring out SWDIO, SWCLK, nRESET, VDD, GND for programming purposes.</b> A reset in the system is triggered by either a system level or core level reset source. A system level reset resets all cores. Examples of system level resets – power-on reset, brownout reset, and pin reset. Examples of core level resets – soft reset, lockup (resets either the entire core or only part of it). Refer to the nRF5340 datasheet for more details: <a href="https://infocenter.nordicsemi.com/topic/ps_nrf5340/keyfeatures_html5.html?cp=3_0_0">https://infocenter.nordicsemi.com/topic/ps_nrf5340/keyfeatures_html5.html?cp=3_0_0</a> SWD- Two-wire interface
<b>Note 5</b> <b>RF_PAD</b>	<b>RF_pad (pin72) is for the BL5340 RF pad variant (453-00053) module only.</b> If using the BL5340 module RF pad variant (453-00053), customer MUST copy the 50-Ohms GCPW RF track design, MUST add series 2nH RF inductor (Murata LQG15HN2N0B02# or Murata LQG15HS2N0B02) and RF connector IPEX MHF4 Receptacle (MPN: 20449-001E) detailed in section <b>50-Ohms RF Trace and RF Match Series 2nH RF inductor on Host PCB for BL5340 RF pad variant (453-00053)</b>
<b>Note 6</b> <b>BL5340PA NC GPIO</b>	<b>The 8 GPIOs signals</b> P0.04/AIN0, P0.29, P0.30, P0.31, P1.00, P1.01, P1.04, P1.05 are NC pins on BL5340PA module series.

### 3.3 Electrical Specifications

#### 3.3.1 Absolute Maximum Ratings

Absolute maximum ratings are the extreme limits for supply voltage and voltages on digital and analogue pins of the module are listed below; exceeding these values causes permanent damage.

**Table 2: Absolute maximum ratings**

Parameter	Min	Max	Unit
Voltage at VDD pin	-0.3	+3.9 (Note 1)	V
Voltage at VDD_HV pin	-0.3	+5.8	V
VBUS	-0.3	+5.8	V
Voltage at GND pin		0	V
Voltage at GPIO pin (at VDD ≤ 3.6V)	-0.3	VDD + 0.3	V
Voltage at GPIO pin (at VDD ≥ 3.6V)	-0.3	3.9	V
NFC antenna pin current (NFC1/2)	-	TBD	mA
Radio RF input level	-	TBD	dBm
<b>Environmental</b>			
Storage temperature	-40	+105	°C
MSL (Moisture Sensitivity Level)	-	4	-
ESD (as per EN301-489)			
Conductive		4	kV
Air Coupling		8	kV
Flash Memory (Endurance) (Note 2)	-	10000	Write/erase cycles
Flash Memory (Retention)	-	10 years at 40 °C	-

#### Absolute maximum Ratings Notes:

<b>Note 1</b>	The absolute maximum rating for VDD pin (max) is 3.9V for the BL5340.
<b>Note 2</b>	Wear levelling can be implemented by customer.

### 3.3.2 Recommended Operating Parameters

**Table 3: Power supply operating parameters**

Parameter	Min	Typ	Max	Unit
VDD (independent of DCDC) supply range	1.7	3.0	3.6	V
VDD_HV (independent of DCDC) supply range	2.5	3.7	5.5	V
VBUS USB supply range	4.35	5	5.5	V
VDD Maximum ripple or noise (See <a href="#">Note 1</a> )	-	-	10	mV
Time in Power-on reset after supply reaches minimum operating voltage, depend on supply rise time.				
VDD supply rise time (0V to 1.7V) <sup>2</sup> 10uS	-	0.7	1.0	mS
VDD supply rise time (0V to 1.7V) <sup>2</sup> >10mS	-	0	-	mS
Operating Temperature Range	-40	+25	+105	°C

**Recommended Operating Parameters Notes:**

<b>Note 1</b>	This is the maximum VDD or VDD_HV ripple or noise (at any frequency) that does not disturb the radio.
<b>Note 2</b>	The on-board power-on reset circuitry may not function properly for rise times longer than the specified maximum.
<b>Note 3</b>	<p>BL5340 power supply options:</p> <ul style="list-style-type: none"> <li><b>Option 1</b> – Normal voltage power supply mode entered when the external supply voltage is connected to both the VDD and VDD_HV pins (so that VDD equals VDD_HV). Connect external supply within range 1.7V to 3.6V range to BL5340 VDD and VDD_HV pins. OR</li> <li><b>Option 2</b> – High voltage mode power supply mode (using BL5340 VDD_HV pin) entered when the external supply voltage is ONLY connected to the VDD_HV pin and the VDD pin is not connected to any external voltage supply. Connect external supply within range 2.5V to 5.5V range to BL5340 VDD_HV pin. BL5340 VDD pin left unconnected.</li> </ul> <p>For either option, if you use USB interface then the BL5340 VBUS pin must be connected to external supply within the range 4.35V to 5.5V. When using the BL5340 VBUS pin, you MUST externally fit a 4.7uF to ground.</p>

**Table 4: Signal levels for interface, GPIO**

Parameter	Min	Typ	Max	Unit
V <sub>IH</sub> Input high voltage	0.7 VDD		VDD	V
V <sub>IL</sub> Input low voltage	VSS		0.3 x VDD	V
V <sub>OH</sub> Output high voltage				
(std. drive, 0.5mA, VDD ≥ 1.7V)	VDD - 0.4		VDD	V
(high-drive, 3mA, VDD ≥ 1.7V)	VDD - 0.4		VDD	V
(high-drive, 5mA, VDD ≥ 2.7V)	VDD - 0.4		VDD	V
V <sub>OL</sub> Output low voltage				
(std. drive, 0.5mA, VDD ≥ 1.7V)	VSS		VSS + 0.4	V
(high-drive, 3mA, VDD ≥ 1.7V)	VSS		VSS + 0.4	V
(high-drive, 5mA, VDD ≥ 2.7V)	VSS		VSS + 0.4	V
V <sub>OL</sub> Current at VSS + 0.4V, Output set low				
(std. drive, VDD ≥ 1.7V)	1	2	4	mA
(high-drive, VDD ≥ 1.7V)	3	-	-	mA
(high-drive, VDD ≥ 2.7V)	6	-	-	mA
QSPI (high-drive, VDD ≥ 1.7V))	-	10	-	mA
TWIM (high-drive, VDD ≥ 1.7V))	-	50	-	mA
V <sub>OH</sub> Current at VDD - 0.4, Output set high				
(std. drive, VDD ≥ 1.7V)	1	2	3	mA
(high-drive, VDD ≥ 2.7V)	6	-	-	mA
(high-drive, VDD ≥ 1.7V)	3	-	-	mA
QSPI (high-drive, VDD ≥ 1.7V))	-	10	-	mA
Pull up resistance		13		kΩ

Parameter	Min	Typ	Max	Unit
Pull down resistance		13		kΩ
Pad capacitance		1.5		pF
Pad capacitance at NFC pads		4		pF
Leakage current between NFC pads when driven to different states		1	10	uA

**Signal Levels Notes:**

- Note 1** The GPIO (GPIO) high reference voltage always equals the level on the VDD pin.
- Normal voltage mode – The GPIO high level equals the voltage supplied to the VDD pin
  - High voltage mode – The GPIO high level equals the level specified (is configurable to 1.8V, 2.1V, 2.4V, 2.7V, 3.0V, and 3.3V. The default voltage is 1.8V. In High voltage mode, the VDD pin becomes an output voltage pin. The VDD output voltage and hence the GPIO is configurable from 1.8V to 3.3V with possible settings of 1.8V, 2.1V, 2.4V, 2.7V, 3.0V, and 3.3V. Refer to [Table 10](#).

**Table 5: GPIO pin alternative function AIN (ADC) specification**

Parameter	Min	Typ	Max	Unit
ADC channels (AIN), single ended (SE) or differential		SE or DE		
ADC channels (AIN)		AIN0 to AIN7		
ADC channels other through VDD pin		VDD		
ADC channels other through VDDH pin		VDDHDIV5		
ADC modes (single channel)		One-shot mode or Continuous mode		
ADC modes (multiple channel)		Scan mode		
ADC Internal reference voltage Input range or		(±0.6)/Gain		V
ADC External VDD as reference voltage Input range		(±VDD/4)/Gain		V
ADC pin input				Scaling
internal selectable scaling gain		4, 2, 1, 1/2, 1/3, 1/4, 1/5 1/6		gain
ADC input pin (AIN) voltage maximum without damaging ADC w.r.t (see <a href="#">Note 1</a> )				
VCC Prescaling (Gain)				
0V-VDD	4, 2, 1, 1/2, 1/3, 1/4, 1/5, 1/6	VSS	VDD+0.3	V
Configurable Resolution	8	10	12	bits
Configurable Resolution with oversampling	-	-	14	bits
Maximum sampling rate			200	kHz
Configurable (see <a href="#">Note 2</a> )				
Acquisition Time, source resistance ≤10kΩ		3		uS
Acquisition Time, source resistance ≤40kΩ		5		uS
Acquisition Time, source resistance ≤100kΩ		10		uS
Acquisition Time, source resistance ≤200kΩ		15		uS
Acquisition Time, source resistance ≤400kΩ		20		uS
Acquisition Time, source resistance ≤800kΩ		40		uS
Conversion Time (see <a href="#">Note 3</a> )		2		uS
ADC input impedance (during operation) (see <a href="#">Note 3</a> )				
Input Resistance		1		MΩ
Sample and hold capacitance at maximum gain		2.5		pF

**Recommended Operating Parameters Notes:**

<b>Note 1</b>	On AIN pin, do not violate ADC maximum input voltage (for damage) for a given VDD, e.g. With internal reference, single ended input (ground negative input) and gain of 1/6, the input range is equal to $(0.6V)/(1/6)$ or 3.6V. If VDD is 3.6V, you can only expose AIN pin to $VDD+0.3V$ . With reference chosen as VDD, single ended input (ground negative input) and gain of 1/4 the input range is equal to $(VDD/4)/(1/4)$ or VDD.
<b>Note 2</b>	<p>ADC resolution (8-bit, 10-bit, 12-bit, 14bit mode), acquisition time, gain, reference voltage source, single ended or differential input, ADC mode and oversampling (for 14bit mode) are configurable. BL5340 ADC is a Successive Approximation type ADC (SSADC). As a result, no external capacitor is needed for ADC operation. Configure the acquisition time according to the source resistance of external connection to ADC (that customer has).</p> <p>In Continuous mode, the sampling frequency is limited by the sum of sampling time and acquisition time (<math>f_{sample} &lt; 1/(t_{ACQ} + t_{conv})</math>). The maximum sampling time is 2us. For acquisition time of 3us the total conversion time is therefore 5us, which makes maximum sampling frequency of <math>1/5us = 200kHz</math>. Similarly, if acquisition time of 40us chosen, then the conversion time is 42us and the maximum sampling frequency is <math>1/42us = 23.8kHz</math>.</p> <p>In scan mode the sample time is the time it takes to sample all channels (Total sample time &lt; <math>\sum(CH[x] \times (t_{ACQ} + t_{conv}))</math> where <math>x=0..enabled\ channels</math>).</p> <p>When using VDDHDIV5 as input, the acquisition time needs to be 10uS or higher.</p>
<b>Note 3</b>	ADC input impedance is estimated mean impedance of the ADC (AIN) pins.

### 3.4 Application Core and Network Core

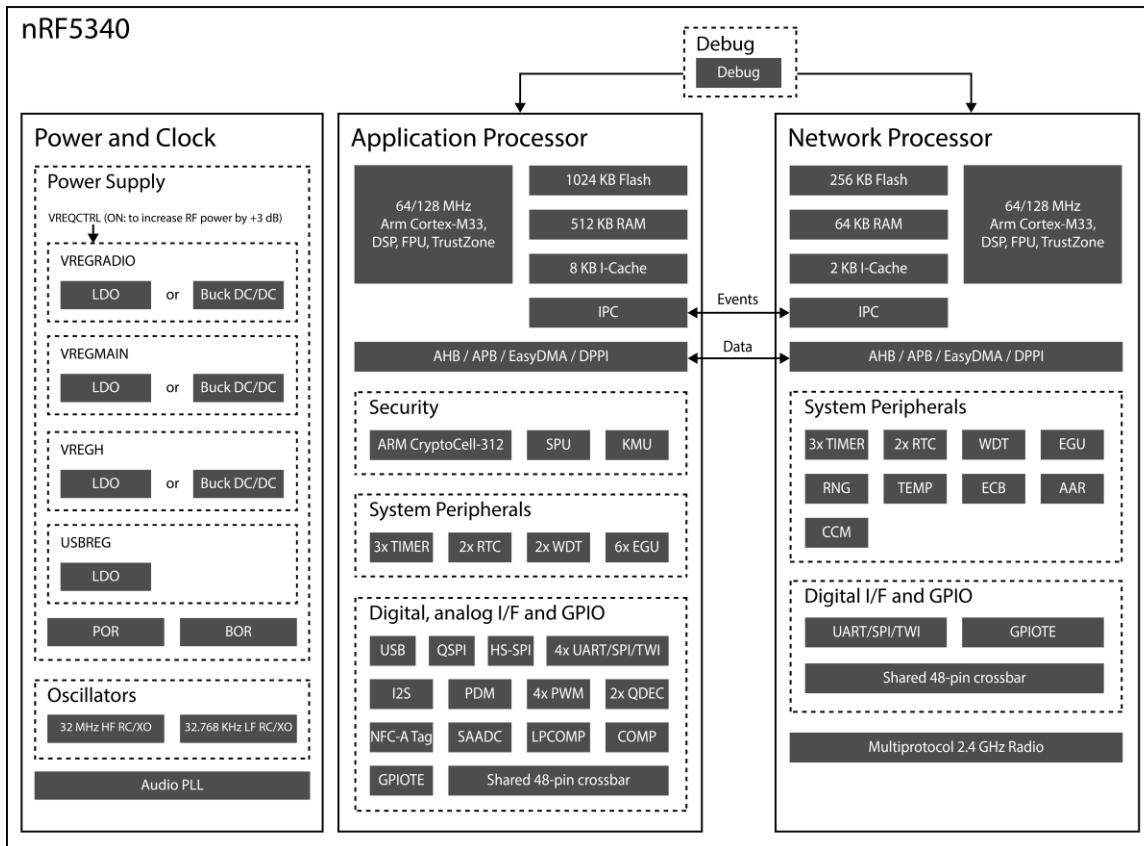

Figure 4: nRF5340 SoC SW block diagram (adapted from Nordic)

nRF5340 SoC (block diagram [Figure 4](#)) contains two processors:

- Applications Core (high performance)
  - Arm Cortex-M33 with DSP (Digital Signal Processing) and FPU (Floating Point Unit), TrustZone support, 1024 kB Flash, 512 kB RAM, 8 kB 2-way set associative cache (serves both internal and external memory), 128 MHz and 64 MHz clock speed, fully programmable and optimized for performance and uses voltage and clock frequency scaling.
  - Security ([Figure 4](#))
  - System Peripherals ([Figure 4](#))
  - Digital, analog interfaces and GPIO ([Figure 4](#))
- Network Core (ultra-low power)
  - Arm Cortex-M33, 256 kB Flash, 64 kB RAM, 2 kB instructions cache, 64 MHz clock speed, fully programmable and optimized for efficiency
  - System Peripherals ([Figure 4](#))
  - Digital interfaces and GPIO ([Figure 4](#))
  - Radio ([Figure 4](#))

## 3.5 Clocks

### 3.5.1 HF XO - 32MHz crystal oscillator and nRF53 internal load capacitor 13.5pF mandatory setting

The BL5340 module contains the 32 MHz crystal, but the load capacitors to create 32MHz crystal oscillator circuit are inside the nRF5340 chipset. Customer MUST set the internal nRF5340 capacitors to 13.5pF (for proper operation of the 32 MHz crystal circuit).

The 32 MHz crystal inside the BL5340 module is a high accuracy crystal ( $\pm 15$  ppm at room temperature) that helps with radio operation and reducing power consumption in the active modes.

### 3.5.2 LFCLK - Low Frequency clock source

There are four possibilities (see figure 5) for the low frequency clock (LFCLK) and options are:

**LFRC (32.768kHz RC oscillator):** The Internal 32.768 kHz RC oscillator (LFRC) is fully embedded in nRF5340 (and does not require additional external components) with an accuracy  $\pm 250$  ppm (after calibration of LFRC at least every eight seconds using the HF XO as a reference oscillator). See section [LF XO - OPTIONAL 32.768kHz Crystal and Load Capacitor](#).

**LF XO (32.768kHz crystal oscillator):** For higher LFCLK accuracy (greater than  $\pm 250$ ppm accuracy is required), the low frequency crystal oscillator (LF XO) must be used. To use LF XO, a 32.768kHz crystal must be connected between the XL1 and XL2 pins and the load capacitance between each crystal terminal and ground. Optionally internal (to nRF53) capacitors of 6pF, 7pF and 9pF are provided on pins XL1 and XL2. See section [LF XO - OPTIONAL 32.768kHz Crystal and Load Capacitor](#).

**Low frequency (32.768 kHz) external source:** The 32.768 kHz oscillator (LF XO) is designed to work with external sources. Following external sources are supported:

- **A low swing clock. The signal should be applied to the XL1 pin with XL2 pin grounded.**
  - In "external low-swing mode" the clock signal can either be a sinewave or a square wave, but it's not allowed to be rail-to-rail. The signal is passed through the LF XO module for amplification and conversion into a digital clock. The amplifier requires a peak-to-peak input amplitude of between 200mV and 1000mV; too high or low amplitude may affect the integrity of the clock. The DC offset of the external signal is flexible, but it must not be so high that XL1 peaks above VDD, or so low that XL1 dips below VSS.
- **A rail-to-rail clock. The signal should be applied to the XL1 pin with XL2 pin left unconnected.**
  - In "external full-swing mode" the LF XO is in reality disabled and the XL1 pin configured as a digital input. Hence, the external clock signal must be a digital waveform, with 'high' and 'low' levels as specified in the GPIO chapter. The full-swing mode will consume slightly less current since the internal signal amplifier is not needed and thus powered down. In "external full-swing mode" the XL2 pin is not connected to anything internally but advise to ground any unused pins.

See [LF XO - OPTIONAL 32.768kHz Crystal and Load Capacitor](#) in the last row of [Table 7](#).

**LFSYNTH (32.768kHz Synthesised clock) from HFCLK (LFSYNTH):** The LFCLK can be synthesised from the HFCLK source. LFSYNTH depends on the HFCLK to run. The accuracy of the LFCLK clock with LFSYNTH as a source assumes the accuracy of the HFCLK. If high accuracy is required, the

HFCLK must be generated from the HF XO. Using the LFSYNT clock removes the requirement for an external 32.768kHz crystal but increases the average power consumption as the HFCLK will be turned on in the system.

**3.5.2.1 LFXO - OPTIONAL 32.768kHz Crystal and Load Capacitor**

**This is not required for normal BL5340 module operation.**

The nRF5340 on-chip 32.768 kHz LFRC oscillator ( $\pm 250$  ppm) provides protocol timing and helps with radio power consumption in the System ON Idle and System OFF modes by reducing the time that the RX window needs to be open.

To maintain accuracy of the nRF5340 on-chip 32.768 kHz LFRC oscillator within  $\pm 250$  ppm (which is needed to run the BLE stack), LFRC oscillator needs to be calibrated (which takes 32 ms) regularly. The calibration interval is at least eight seconds which is enough to keep within  $\pm 250$  ppm.

You can connect an optional external high accuracy ( $\pm 20$  ppm) 32.768 kHz crystal (and associated load capacitors can be external capacitors or use capacitance inside the nRF5340 chipset, which are configurable to either 6pF, 7pF, or 9pF) to the BL5340 P0.01/XL2 (pin 32) and P0.00/XL1 (pin 34). This provides improved protocol timing and to help with radio power consumption in the System ON Idle or System OFF sleep modes by reducing the time that the RX window needs to be open. **Table 6** compares the current consumption difference between RC (LFRC) and crystal oscillator (LFXO).

**Table 6: Comparing current consumption difference between BL5340 on-chip LFRC 32.768 kHz oscillator and optional external crystal (32.768kHz) based oscillator**

	BL5340 on-chip 32.768 kHz RC Oscillator ( $\pm 250$ ppm) LFRC	Optional External Higher Accuracy ( $\pm 20$ ppm) 32.768 kHz Crystal-based Oscillator LFXO
<b>Current Consumption of 32.768 kHz Block</b>	1.0 $\mu$ A	0.16 $\mu$ A
<b>System ON idle + NET Core 64kB RAM + APP Core 8kB RAM retention +RTC run current + LFRC or LFXO)</b>	2.6 $\mu$ A	2.1 $\mu$ A
<b>Calibration</b>	<p>Calibration required regularly (default eight seconds interval).</p> <p>Calibration takes 32 ms; with DCDC used, the total charge of a calibration event is 12.6 <math>\mu</math>C.</p> <p>The average current consumed by the calibration depends on the calibration interval and can be calculated using the following formula:</p> <p><b>CAL_charge/CAL_interval</b> - The lowest calibration interval (0.25 seconds) provides an average current of (DCDC enabled):</p> <p><b>12.6<math>\mu</math>C/0.25s = 50.4<math>\mu</math>A</b></p> <p>To get the <math>\pm 250</math>-ppm accuracy, the BLE stack specification states that a calibration interval of eight seconds is enough. This gives an average calibration current of:</p> <p><b>12.6<math>\mu</math>C/8s = 1.6<math>\mu</math>A</b></p> <p>Added to the LFRC run current and System ON Idle base current shown above results in a total average current of:</p> <p><b>LFRC + CAL = 2.6 + 1.6 = 4.2 <math>\mu</math>A</b></p>	Not applicable
<b>Total</b>	4.2 $\mu$ A	2.1 $\mu$ A
<b>Summary</b>	<ul style="list-style-type: none"> <li>Low current consumption</li> <li>Accuracy <math>\pm 250</math> ppm</li> </ul>	<ul style="list-style-type: none"> <li>Lowest current consumption</li> <li>Needs external crystal</li> <li>High accuracy (depends on the crystal, usually <math>\pm 20</math> ppm)</li> </ul>

**BL5340 on-chip 32.768 kHz RC Oscillator  
(±250 ppm) LFRC**

**Optional External Higher Accuracy (±20 ppm)  
32.768 kHz Crystal-based Oscillator LFXO**

**Results with below test setup:**

- Network core enabled
  - DCDC enabled
  - 64kB RAM retained
  - RTC enabled
  - Running BLE stack
- Application core enabled
  - DCDC enabled
  - 8kB RAM retained
  - RTC enabled
  - Running zephyr OS
- 3V supply on VDD
  - VDDH disabled
  - DCDC VDDH disabled

**Table 7: Optional external 32.768 kHz crystal specification and Low frequency (32.768kHz) external source specification**

Optional external 32.768kHz crystal	Min	Typ	Max
Crystal Frequency	-	32.768 kHz	-
Frequency tolerance requirement of BLE stack	-	-	±500 ppm
Load Capacitance	-	7 pF	9 pF
Shunt Capacitance	-	1 pF	2 pF
Equivalent series resistance	-	60 kOhm	90 kOhm
Drive level	-	-	0.5 μW
Input capacitance on XL1 and XL2 pads with internal capacitor disabled	-	4 pF	-
Input capacitance on XL1 and XL2 pads with internal capacitor enabled	6 pF	7 pF	9 pF
Peak to peak amplitude for <b>external low swing clock</b> . Input signal must not be outside supply rails. The allowable input amplitude range in low-swing mode does not change with VDD.	200 mV	-	1000 mV

Be sure to tune the load capacitors on the board design to optimize frequency accuracy (at room temperature) so it matches that of the same crystal standalone, Drive Level (so crystal operated within safe limits) and oscillation margin ( $R_{neg}$  is at least 3 to 5 times ESR) over the operating temperature range.

### 3.5.3 Other Internal Clocks

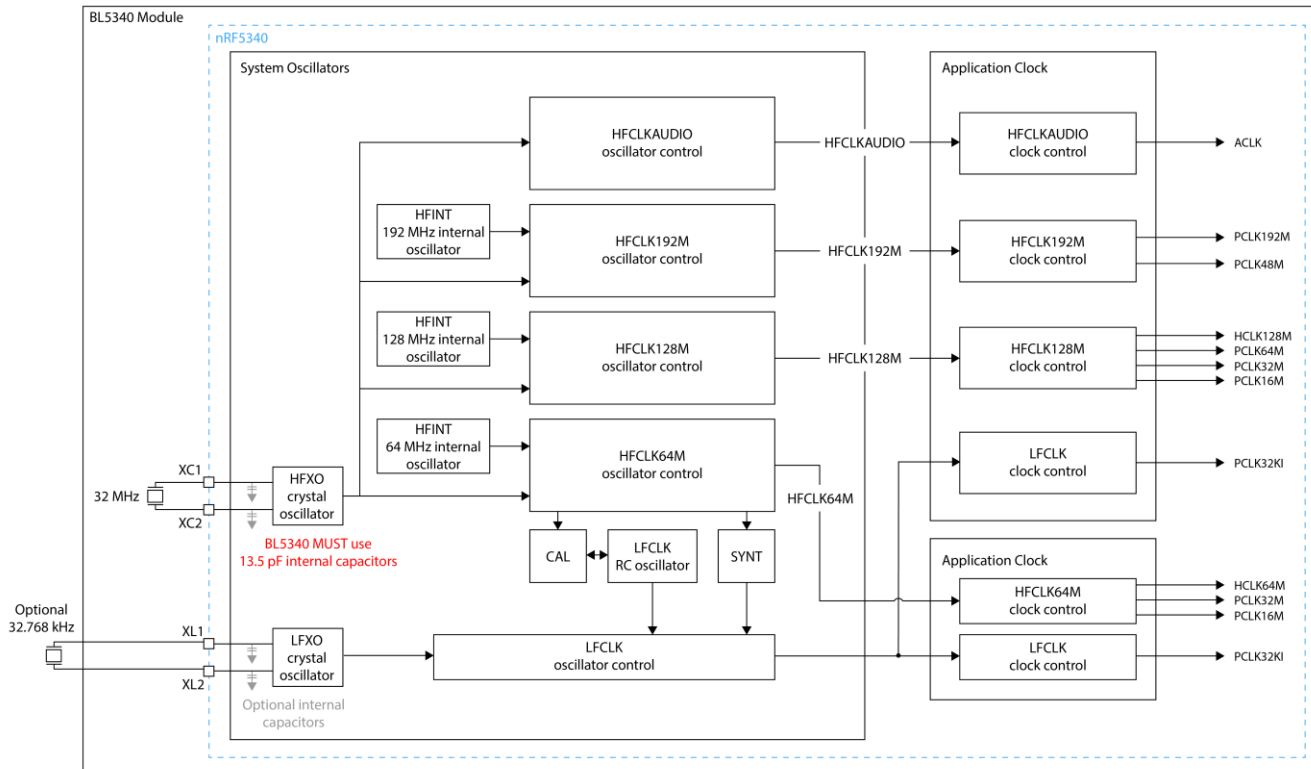

Figure 5: nRF5340 SoC clocks (adapted from Nordic)

Table 8: Core clocks

Core clock	Description
HFCK128M	Scalable 128 MHz CPU clock for the application core
HFCK64M	64 MHz CPU clock for the network core
PCLK192M	Scalable 192 MHz clock for QSPI
PCLK64M	64 MHz peripheral clock
PCLK48M	48 MHz clock for USB
PCLK32M	32 MHz peripheral clock
PCLK16M	16 MHz peripheral clock
ACLK	11.289 MHz or 12.288 MHz tuneable audio peripheral clock

## 3.6 BL5340 Power Supply Options

Power management features:

- System ON Idle, System OFF and Force-OFF mode.
- Open/Close peripherals (UART, SPI, QSPI, I2C, GPIOs, ADC, NFC, I2S, PDM etc.). Peripherals consume current when open; each peripheral can be individually closed to save power consumption
- Use of the internal DCDC convertor or LDO
- Supply voltage to be read (through the internal ADC)
- Pin wake-up system from System OFF (including from NFC pins)

Power supply features:

- Supervisor hardware to manage power during reset, brownout, or power fail.

- 1.7V to 3.6V supply range for normal power supply (VDD pin) using internal DCDC convertor or LDO
- 2.5V to 5.5 supply range for High voltage power supply (VDD\_HV pin) using internal DCDC convertor or LDO
- 4.35V to 5.5V supply range for powering USB (VBUS pin) portion of BL5340 only. The remainder of the BL5340 module circuitry must still be powered through the VDD (or VDD\_HV) pin.

The BL5340 module power supply internally contains the following two main supply regulator stages (Figure 6):

- VREGH – Connected to the VDD\_HV pin
- VREGMAIN and VREGRADIO – Connected to the VDD pin

The USB peripheral is powered separately (connected to the VBUS pin).

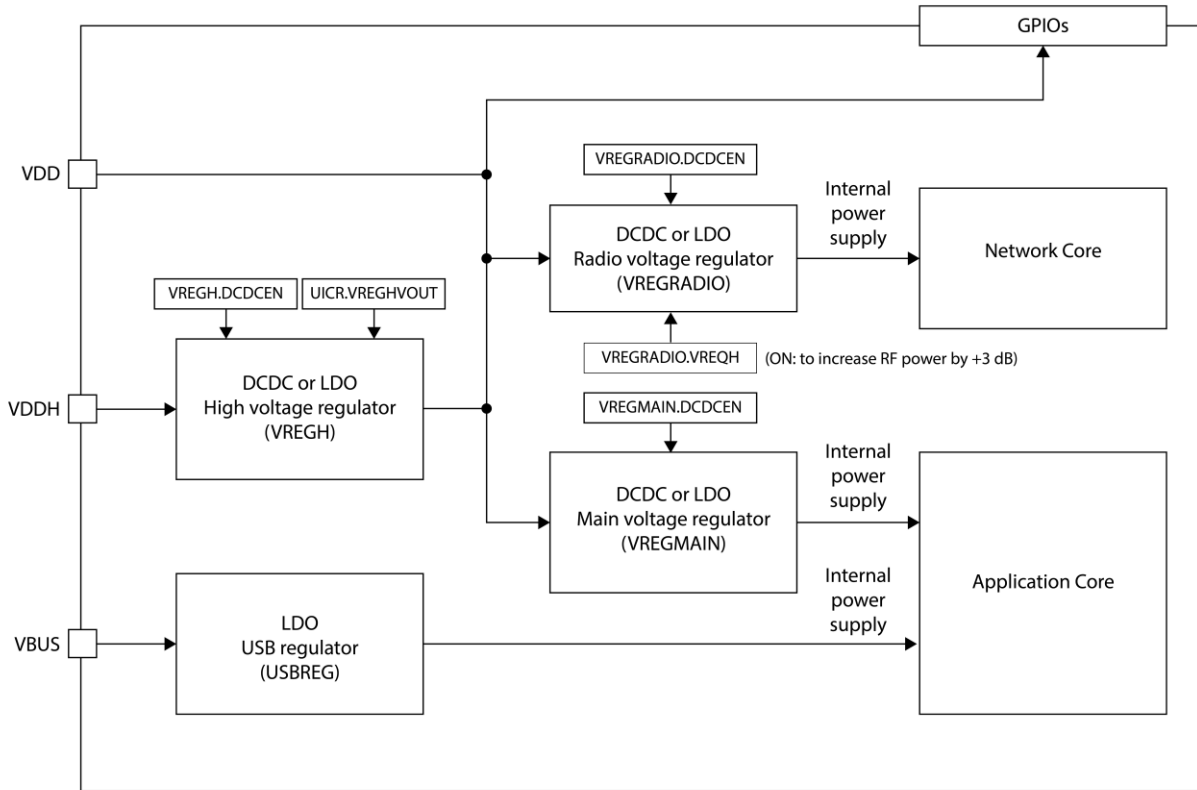

Figure 6: BL5340 power supply block diagram (adapted from the following resource: [https://infocenter.nordicsemi.com/topic/ps\\_nrf5340/keyfeatures\\_html5.html?cp=3\\_0\\_0](https://infocenter.nordicsemi.com/topic/ps_nrf5340/keyfeatures_html5.html?cp=3_0_0))

### 3.6.1 Normal Voltage mode (option1) or High Voltage mode (option2)

The BL5340 power supply system enters one of two supply voltage modes, Normal or High voltage mode, depending on how the external supply voltage is connected to these pins.

BL5340 power supply options:

- **Option 1** – Normal voltage power supply mode entered when the external supply voltage is connected to both the VDD and VDD\_HV pins (so that VDD equals VDD\_HV). Connect external supply within range 1.7V to 3.6V range to BL5340 VDD and VDD\_HV pins.

OR

- **Option 2** – High voltage mode power supply mode (using BL5340 VDD\_HV pin) entered when the external supply voltage is ONLY connected to the VDD\_HV pin and the VDD pin is not connected to any external voltage supply. Connect external supply within range 2.5V to 5.5V range to BL5340 VDD\_HV pin. BL5340 VDD pin left unconnected.

For either option, if you use USB interface then the BL5340 VBUS pin must be connected to external supply within the range 4.35V to 5.5V. When using the BL5340 VBUS pin, you **MUST** externally fit a 4.7uF to ground.

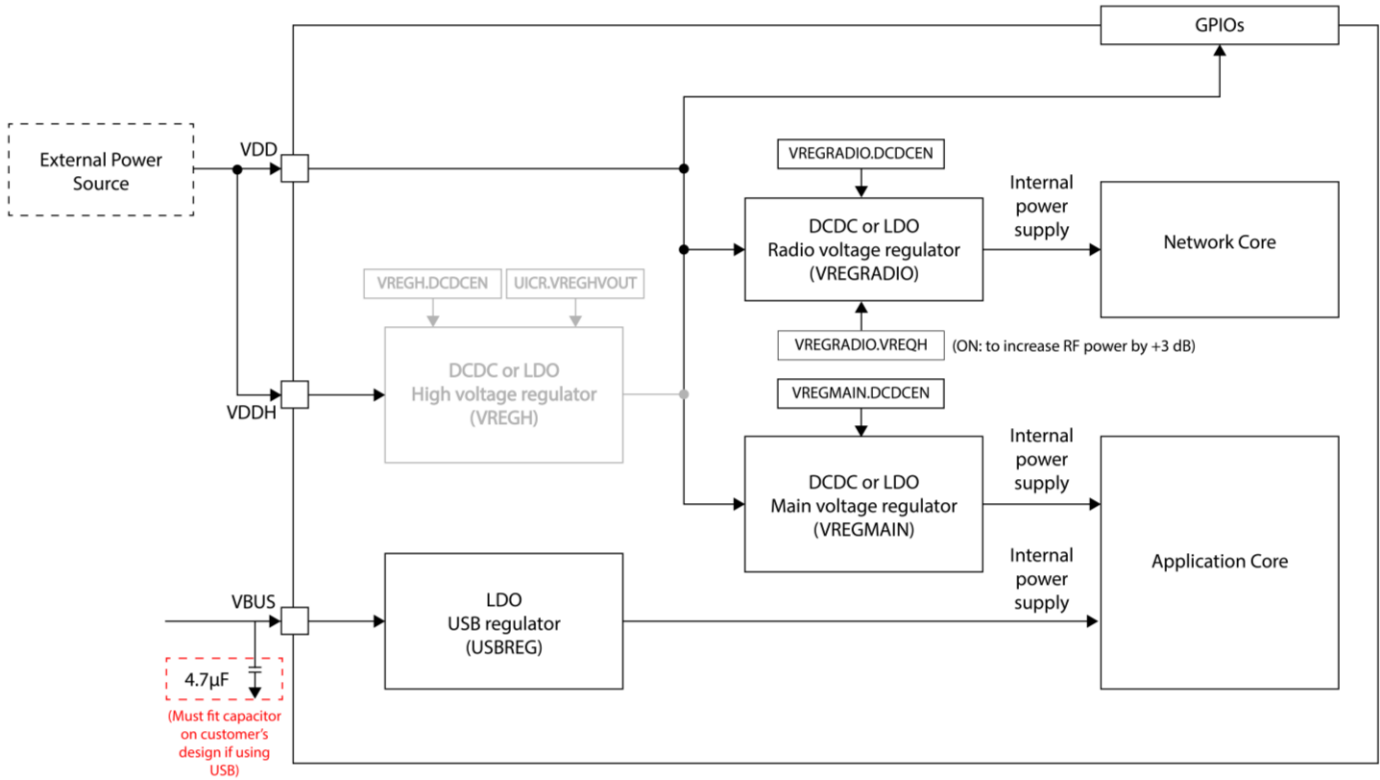

Figure 7: Normal Voltage mode (option1)

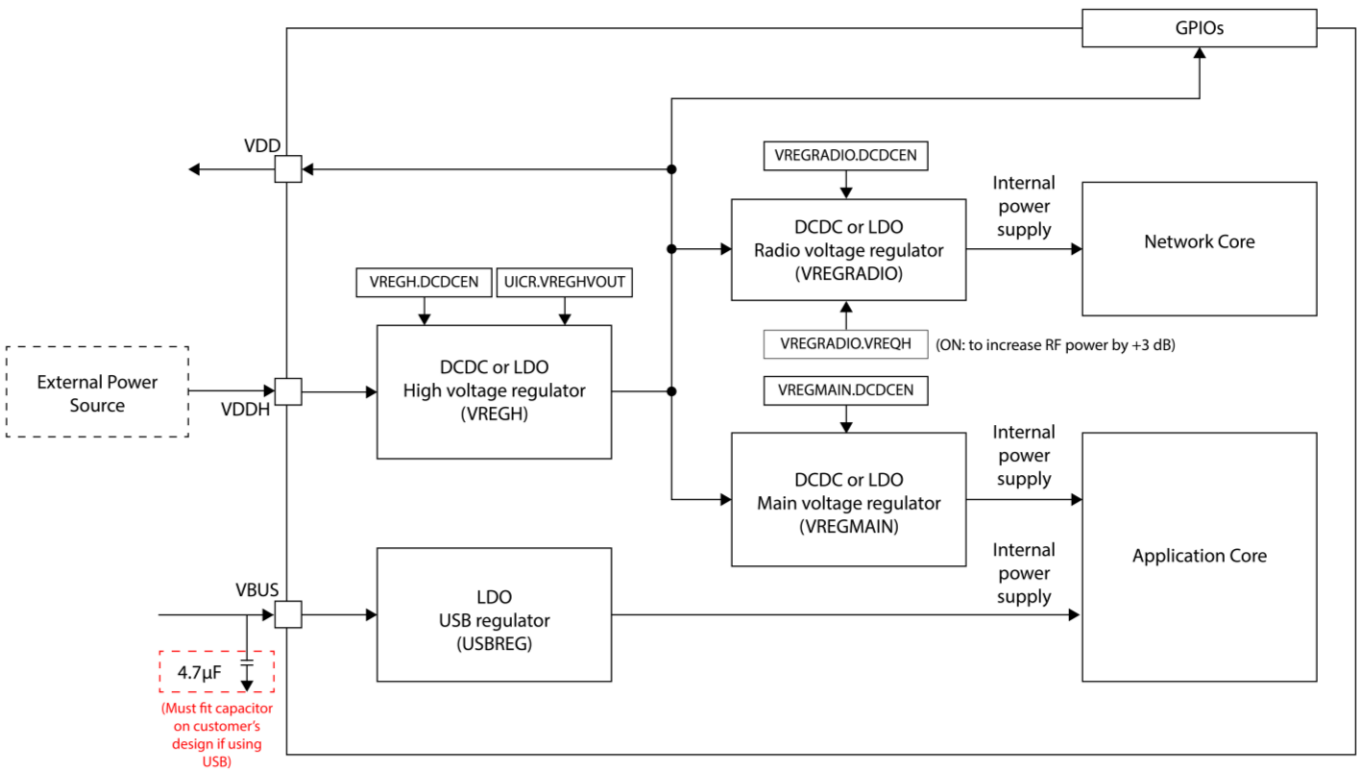

Figure 8: High Voltage Mode (option2)

Table 9 summarizes these power supply options.

**Table 9: BL5340 powering options**

Power Supply Pins and Operating Voltage Range	OPTION 1: Normal voltage mode. Module pins to connect external supply.	OPTION 2: High voltage mode. Module pins to connect external supply.	OPTION 1 with USB peripheral, and Normal voltage mode. Module pins to connect external supply.	OPTION 2 with USB peripheral and high voltage mode. Module pins to connect external supply.
VDD (pin31) 1.7V to 3.6V	Yes (See Note 1)	No (See Note 2)	Yes	No (See Section 3.6.2)
VDD_HV (pin35) 2.5V to 5.5V	No	Yes	No	Yes (See Section 3.6.2)
VBUS (pin40) 4.35V to 5.5V	No	(See Note 3)	Yes (See Section 3.6.2)	Yes (See Section 3.6.2)

**Power Supply Option Notes:**

**Note 1** **Option 1** – External supply voltage is connected to BOTH the VDD and VDD\_HV pins (so that VDD equals VDD\_HV). Connect external supply within range 1.7V to 3.6V range to BOTH BL5340 VDD and VDD\_HV pins.

**Note 2** **Option 2** – External supply within range 2.5V to 5.5V range to the BL5340 VDD\_HV pin ONLY. BL5340 VDD pin left unconnected.

In High voltage mode, the VDD pin becomes an output voltage pin. It can be used to supply external circuitry from the VDD pin. Before any current can be taken from the BL5340 VDD pin, this feature must be enabled in the BL5340. Additionally, the VDD output voltage is configurable from 1.8V to 3.3V with possible settings of 1.8V, 2.1V, 2.4V, 2.7V, 3.0V, and 3.3V. The default voltage is 1.8V.

The supported BL5340 VDD pin output voltage range depends on the supply voltage provided on the BL5340 VDD\_HV pin. The minimum difference between voltage supplied on the VDD\_HV pin and the voltage output on the VDD pin is 0.3V. The maximum output voltage of the VDD pin is  $VDDH - 0.3V$ . Table 10 shows the current that can be drawn by external circuitry from VDD pin in high voltage mode (supply on VDD\_HV).

**Table 10: Current that can be drawn by external circuitry from VDD pin in High voltage mode (supply on VDD\_HV)**

Parameter	Min	Typ	Max	Unit
External current draw (from VDD pin) allowed in High Voltage mode (supply on VDD_HV) during System OFF (BL5340 System OFF)			1	mA
External current draw (from VDD pin) NOTE3A allowed in High Voltage mode (supply on VDD_HV) when VREGMAIN and VREGRADIO are in DCDC mode. Assumes worst case power consumption for both cores (NOTE3B) and at the lowest VDD output voltage setting.			7	mA
External current draw (from VDD pin) NOTE3A allowed in High Voltage mode (supply on VDD_HV) when VREGMAIN and VREGRADIO are in LDO mode. Assumes worst case power consumption for both cores (NOTE3B) and at the lowest VDD output voltage setting.			1	mA
Minimum difference between voltage supplied on VDD_HV pin and output voltage on VDD pin (configured in VREGHOUT), $VDD\_HV > VDD$			0.3	V
VDD output voltage	1.8		3.3	V
VDD output voltage error (deviation from setting in)	-10		+5	%

A: External current draw is the sum of all GPIO currents and current being drawn from VDD.

B: In practice, the maximum external current draw is limited by the maximum output current of VREGH, subtracting the actual current being drawn from VDD.

**Note 3** Depends on whether USB operation is required. See [VBUS pin and 4.7uF Mandatory Capacitor](#) if USB peripheral is to be used.

### 3.6.2 VBUS pin and 4.7uF Mandatory Capacitor

To use the BL5340 USB peripheral:

1. Connect the BL5340 VBUS pin to the external supply within the range 4.35V to 5.5V. When using the BL5340 VBUS pin, you **MUST** externally fit a 4.7uF to ground. Ensure capacitor value reduction due to DC bias, AC bias, temperature is minimized.
2. Connect the external supply to either the VDD (Option 1) or VDD\_HV (Option 2) pin to operate the rest of BL5340 module.

When using the BL5340 USB peripheral, the VBUS pin can be supplied from same source as VDD\_HV (within the operating voltage range of the VBUS pin and VDD\_HV pin).

An optional series 4.7ohms resistor on the USB supply (VBUS) can be fitted for improved immunity to transient over-voltage VBUS connection.

If not using USB peripheral, the VBUS pin can be left unconnected.

### 3.6.3 VREQCTRL - Voltage request control (VREQCTRL ON for +3dB extra RF TX power)

The VREQCTRL can request additional voltage on VREGRADIO regulated supply to support an extra +3dB RF TX power out of the radio.

**Table 11: RF TX Power setting versus VREQCTRL OFF and VREQCTRL ON (to get +3dB extra RF TX power)**

nRF5340 RF TX power setting	Register VREQCTRL OFF Actual nRF5340 RF TX power	Register VREQCTRL ON (to add extra +3 dB) Actual nRF5340 RF TX power
0 dBm	0 dBm	+3 dBm (= 0 dBm +3 dB)
-1 dBm	-1 dBm	+2 dBm (= -1 dBm +3 dB)
-2 dBm	-2 dBm	+1 dBm (= -2 dBm +3 dB)
-3 dBm	-3 dBm	0 dBm (= -3 dBm +3 dB)
-4 dBm	-4 dBm	-1 dBm (= -4 dBm +3 dB)
-5 dBm	-5 dBm	-2 dBm (= -5 dBm +3 dB)
-6 dBm	-6 dBm	-3 dBm (= -6 dBm +3 dB)
-7 dBm	-7 dBm	-4 dBm (= -7 dBm +3 dB)
-8 dBm	-8 dBm	-5 dBm (= -8 dBm +3 dB)
-12 dBm	-12 dBm	-9 dBm (= -12 dBm +3 dB)
-16 dBm	-16 dBm	-13 dBm (= -16 dBm +3 dB)
-20 dBm	-20 dBm	-17 dBm (= -20 dBm +3 dB)
-40 dBm	-40 dBm	-37 dBm (= -40 dBm +3 dB)

### 3.6.4 Low Power Modes

The nRF5340 chipset (BL5340 module) has four power modes: Active, System ON Idle, System OFF and Force-OFF mode.

For low power consumption, the module can be placed automatically in System ON Idle if there are no pending events. The module wakes from System ON Idle via any interrupt (such as a received character on the UART Rx line). If the module receives a UART character from either the external UART or the radio, it wakes up.

System OFF is the lowest power mode. Once awakened, the system goes through a system reset.

Force-OFF is only applicable for network core.

## 3.7 Programmability

### 3.4.1 BL5340 Default Firmware

The BL5340 module is shipped from Ezurio manufacturing facilities with no firmware loaded.

#### 3.7.1 BL5340 Firmware options

Firmware for use with the BL5340 can be divided into three types.

- **Bootloader** – This is the application that resides on the Application Core used to perform firmware updates of the Application and Network Cores.

The MCUboot [A] or the Trusted Firmware M [B] Bootloaders can be used as the basis for BL5340 Bootloader functionality.

- **Application** – This is the main application code that resides on the Application Core. It interfaces with the Network Core and provides supplementary functionality to that of the time critical activities being performed on the Network Core.

The BL5340 is supported by the Zephyr RTOS [C] and the Nordic Connect SDK [D].

- **Radio Stack** – This is the protocol stack that resides on the Network Core. It controls the radio and performs time critical protocol related operations and provides the results of these to the Application Core for high level processing.

When the Zephyr RTOS is used as the basis for application development, BLE [E] and Thread [F] Radio Stacks are available for use with that platform.

For Nordic Connect SDK based solutions, proprietary BLE [G], Thread [H], Zigbee [I] and ESB [J] protocol stacks are available.

[A] <https://github.com/mcu-tools/mcuboot>

[B] <https://www.trustedfirmware.org/>

[C] <https://zephyrproject.org/>

[D] <https://www.nordicsemi.com/Software-and-tools/Software/nRF-Connect-SDK>

[E] <https://docs.zephyrproject.org/latest/guides/bluetooth/index.html>

[F] <https://openthread.io/platforms/rtos/zephyr>

[G] [https://developer.nordicsemi.com/nRF\\_Connect\\_SDK/doc/latest/nrfxlib/softdevice\\_controller/README.html#softdevice-controller](https://developer.nordicsemi.com/nRF_Connect_SDK/doc/latest/nrfxlib/softdevice_controller/README.html#softdevice-controller)

[H] [https://developer.nordicsemi.com/nRF\\_Connect\\_SDK/doc/latest/nrf/ug\\_thread.html](https://developer.nordicsemi.com/nRF_Connect_SDK/doc/latest/nrf/ug_thread.html)

[I] [https://developer.nordicsemi.com/nRF\\_Connect\\_SDK/doc/latest/nrf/ug\\_zigbee.html](https://developer.nordicsemi.com/nRF_Connect_SDK/doc/latest/nrf/ug_zigbee.html)

[J] [https://developer.nordicsemi.com/nRF\\_Connect\\_SDK/doc/latest/nrf/ug\\_esb.html](https://developer.nordicsemi.com/nRF_Connect_SDK/doc/latest/nrf/ug_esb.html)

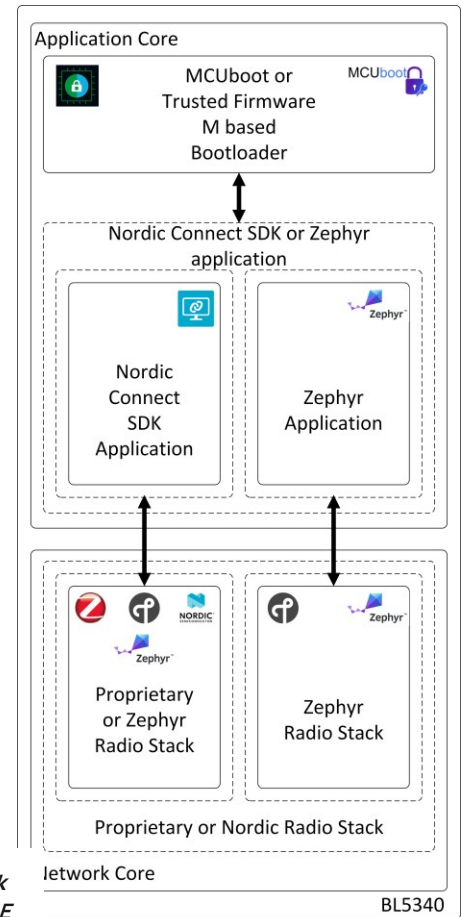

Figure 9: Functional SW block diagram for BL5340 series BLE

## 4 Power Consumption

Normal voltage mode VDD of 3.0 V, using internal (to chipset) DCDC or with internal (to chipset) LDO ON. Temperature 25°C.

**Table 12: Power consumption**

Parameter	Typ (Radio only)	Typ Radio +Application core (20kB RAM) + Network core (64kB RAM)	Unit
<b>Active mode 'peak' current (Note 1)</b> <b>(Advertising or Connection)</b>	With DCDC [with LDO]	With DCDC [with LDO]	
Tx only run peak current @ Txpwr = +3 dBm (Note1A)	5.1 [11.3]	9.1 [21.5]	mA
Tx only run peak current @ Txpwr = 0 dBm	3.4 [9.1]	9.1 [20.2]	mA
Tx only run peak current @ Txpwr = -4 dBm	2.7 [7.2]		
Tx only run peak current @ Txpwr = -8 dBm	2.2 [5.8]		
Tx only run peak current @ Txpwr = -12 dBm	2.0 [5.0]		
Tx only run peak current @ Txpwr = -16 dBm	1.8 [4.5]		
Tx only run peak current @ Txpwr = -20 dBm	1.7 [4.2]		
Tx only run peak current @ Txpwr = -40 dBm	1.5 [3.8]		
<b>Active Mode</b>			
Rx only 'peak' current, BLE 1Mbps (Note 1)	2.7 [6.7]	8.6 [21.5]	mA
Rx only 'peak' current, BLE 2Mbps (Note 1)	3.1 [7.9]	-	mA
<b>Ultra-Low Power Mode 1 (Note 2)</b> System ON Idle (0 k application, network core RAM retention)	1.3		uA
<b>Ultra-Low Power Mode 2 (Note 3)</b> System OFF (0 kB application and network RAM retention)	0.9		uA
<b>Active Mode Average current (Note 4)</b> <b>Advertising Average Current draw</b>			
<b>Max</b> , with advertising interval (min) 20 mS	Note4		uA
<b>Min</b> , with advertising interval (max) 10240 mS	Note4		uA
<b>Connection Average Current draw</b>			
<b>Max</b> , with connection interval (min) 7.5 mS	Note4		uA
<b>Min</b> , with connection interval (max) 4000 mS	Note4		uA

**Power Consumption Notes:**

<b>Note 1</b>	<p>This is for Peak Radio Current only (with VREQCTRL OFF). Also, additional current draw depending on Application Core and Network Core running, RAM, flash used and which peripherals on (if any).</p> <p><b>Note1A:</b> With VREQCTRL ON (get +3 dB extra RF TX power), the Peak Radio current increases by 1 mA to 2 mA.</p>
<b>Note 2</b>	<p>BL5340 modules System ON Idle is 1.3 uA typical (with 0kB application core RAM, wake on any event, network core RAM 0kB, network core forced off). System ON Idle is entered automatically (waiting for an event). In System ON Idle, all peripherals that are enabled stay on and may re-awaken the chip. Depending on active peripherals, current consumption ranges from 1.3 uA to 645 uA (when UART is ON, Idle). See individual peripherals current consumption data in the Peripheral Block Current Consumption section. There is functionality to detect GPIO change with no current consumption cost, it is possible to close the UART and get to the 1.3 uA current consumption regime and still be able to detect for incoming data and be woken up so that the UART can be re-opened at expense of losing that first character.</p> <p>RAM retention current per 4k block is approximately 13nA.</p>

**Note 3** In System OF (0kB application RAM, wake on reset, network core RAM 0kB), everything is disabled, and the only wake-up sources (including NFC to wakeup) are reset and changes on GPIO or NFC pins on which sense is enabled. The current consumption seen is ~0.9 uA typical in BL5340 modules.

- Coming out from System OFF to System ON Idle is through the reset vector.

**Note 4** Average current consumption depends on several factors (including Tx power, VDD, accuracy of 32MHz and 32.768 kHz). With these factors fixed, the largest variable is the advertising or connection interval set.

Advertising Interval range:

- 20 milliseconds to 10240 mS (10485759.375 mS in BT 5.1) in multiples of 0.625 milliseconds.

For an advertising event:

- The minimum average current consumption is when the advertising interval is large (10240 mS, or 10485759.375 mS in BT 5.1) although this may cause long discover times (for the advertising event) by scanners
- The maximum average current consumption is when the advertising interval is small (20 mS).

Other factors that are also related to average current consumption include the advertising payload bytes in each advertising packet and whether it's continuously advertising or periodically advertising.

Connection Interval range (for a peripheral):

- 7.5 milliseconds to 4000 milliseconds in multiples of 1.25 milliseconds.

For a connection event (for a peripheral device):

- The minimum average current consumption is when the connection interval is large (4000 milliseconds)
- The maximum average current consumption is with the shortest connection interval of 7.5 ms; no slave latency.

Other factors that are also related to average current consumption include:

- Number packets per connection interval with each packet payload size
- An inaccurate 32.768 kHz master clock accuracy would increase the average current consumption.

Connection Interval range (for a central device):

- 2.5 milliseconds to 40959375 milliseconds in multiples of 1.25 milliseconds.

## 5 Peripherals

To provide the widest scope for integration, a variety of physical host interfaces/sensors are provided. The major BL5340 series module functional blocks are described below (which are within the nRF5340). Peripherals not mentioned in this section can be looked up in the nRF5340 datasheet [https://infocenter.nordicsemi.com/topic/ps\\_nrf5340/keyfeatures\\_html5.html?cp=3\\_0\\_0](https://infocenter.nordicsemi.com/topic/ps_nrf5340/keyfeatures_html5.html?cp=3_0_0)

### 5.1 RADIO – 2.4GHz radio (RF)

- **2402–2480 MHz Bluetooth Low Energy (BLE) BT5.2 radio transceiver**
  - -98 dBm RX sensitivity 1 Mbps BLE
  - -95 dBm RX sensitivity 2 Mbps BLE
  - -104 dBm RX sensitivity 125 kbps BLE coded PHY (s=8)
  - -100 dBm RX sensitivity 500 kbps BLE coded PHY (s=2)
  - RF Tx output power of +0 dBm programmable down to -1 dBm, -2 dBm, -3 dBm, -4 dBm, -5 dBm, -6 dBm, -7 dBm, -8 dBm, -12 dBm, -16 dBm, -20 dBm, -40 dBm
  - RF TX power (for all RF TX power steps) increases by +3 dB when VREQCTRL is turned ON
  - Angle of Arrival (AoA) and Angle of Departure (AoD) direction finding using BLE
- **2405–2480 MHz IEEE 802.15.5-2006 radio transceiver, implementing IEEE 802.15.5-2006 compliant**
  - 250 kbps, 2450 MHz, O-QPSK PHY
  - Channels 11-26. Channel 11 2405 MHz and CH26 2480 MHz
  - Clear channel assessment (CCA)
  - Energy detection (ED) scan
  - CRC generation
  - -101 dBm RX sensitivity IEEE 802.15.4-2006 250 kbps

- RF Tx output power of +0 dBm programmable down to -1 dBm, -2 dBm, -3 dBm, -4 dBm, -5 dBm, -6 dBm, -7 dBm, -8 dBm, -12 dBm, -16 dBm, -20 dBm, -40 dBm.
  - RF TX power (for all RF TX power steps) increases by +3 dB when VREQCTRL is turned ON.
  - **MANDATORY.** When used in IEEE 802.15.4-2006 PHY mode, channel 26 (2480 MHz), the BL5340 RF TX power must be limited by customer to -8 dBm setting (which produces -5dBm with VREQCTRL ON) maximum RF transmit power to pass FCC/IC Band Edge emissions limit. All other 802.15.4 channels (11-25) may be used up to the maximum 0dBm (which produces +3 dBm with VREQCTRL ON) RF TX output power.
- **2402-2480 MHz proprietary 1 Mbps and 2 Mbps modes radio transceiver (not currently certified by Ezurio)**
    - -95 dBm RX sensitivity, 1 Mbps nRF proprietary mode (ideal transmitter)
    - -92 dBm RX sensitivity, 2 Mbps nRF proprietary mode (ideal transmitter)
    - RF Tx output power of +0 dBm programmable down to -1 dBm, -2 dBm, -3 dBm, -4 dBm, -5 dBm, -6 dBm, -7 dBm, -8 dBm, -12 dBm, -16 dBm, -20 dBm, -40 dBm.
    - RF TX power (for all RF TX power steps) increases by +3 dB when VREQCTRL is turned on.
- **RF interface available in the following two ways:**
    - 453-00052: RF connected to Integrated PCB trace antenna
    - 453-00053: RF connected to RF Trace Pad
      - o Antenna options: External dipole antennas connected with to IPEX MH4 RF connector host board
- **Received Signal Strength Indicator (RSSI)**
    - RSSI accuracy (valid range -90 to -20dBm) is  $\pm 2$ dB typical
    - RSSI resolution 1dB typical

## 5.2 NFC Tag – Near field communication tag

The NFCT peripheral is an implementation of an NFC Forum listening device NFC-A. With appropriate software, the NFCT peripheral can be used as the listening device NFC-A as specified by the <https://nfc-forum.org/>

NFC support:

- Based on the NFC forum specification
  - 13.56 MHz
  - Data rate - 106 kbps
  - NFC Type2 and Type4 tag emulation
- Modes of operation:
  - Disable
  - Sense (Wake-on-field low power field detection (SENSE) mode)
  - Activated

### 5.2.1 Use Cases

- Touch-to Pair with NFC
- Launch a smartphone app (on Android)
- NFC enabled Out-of-Band Pairing
- System Wake-On-Field function
  - Proximity Detection

**Table 13: NFC interface**

Signal Name	Pin No	I/O	Comments
NFC1/P0.02	28	I/O	The NFC pins are by default NFC pins and an alternate function on each pin is GPIO.
NFC2/P0.03	26	I/O	

### 5.2.2 NFC Antenna Coil Tuning Capacitors

From Nordic's nRF5340 datasheet: [https://infocenter.nordicsemi.com/topic/ps\\_nrf5340/keyfeatures\\_html5.html?cp=3\\_0\\_0](https://infocenter.nordicsemi.com/topic/ps_nrf5340/keyfeatures_html5.html?cp=3_0_0)

The NFC antenna coil must be connected differential between the NFC1 and NFC2 pins of the BL5340. Two external capacitors should be used to tune the resonance of the antenna circuit to 13.56 MHz (Figure 10).

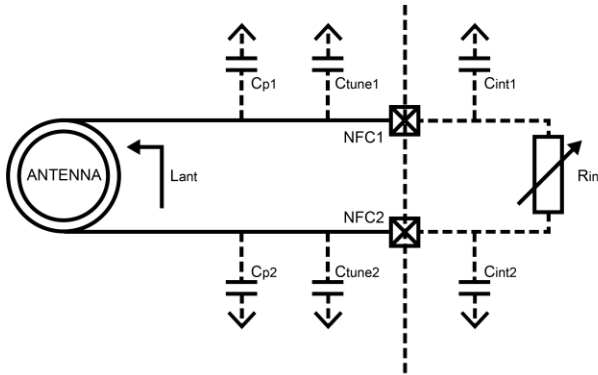

Figure 10: NFC antenna coil tuning capacitors

The required external tuning capacitor value is given by the following equations:

$$C_{tune} = \frac{2}{(2\pi \cdot 13.56 \text{ MHz})^2 \cdot L_{ant}} - C_p - C_{int}$$

An antenna inductance of  $L_{ant} = 0.72 \mu\text{H}$  provides tuning capacitors in the range of 300 pF on each pin. The total capacitance on NFC1 and NFC2 must be matched.  $C_{int}$  and  $C_p$  are small usually ( $C_{int}$  is 4pF), so can omit from calculation.

**Battery Protection Note:** If the NFC coil antenna is exposed to a strong NFC field, the supply current may flow in the opposite direction due to parasitic diodes and ESD structures.

If the used battery does not tolerate a return current, a series diode must be placed between the battery and the BL5340 to protect the battery.

For more details, see the NFC flexi PCB antenna (Ezurio 0600-0061) datasheet:

<https://www.ezurio.com/documentation/datasheet-nfc-flex-pcb-antenna>

## 5.3 UARTe – Universal asynchronous receiver/transmitter with Easy DMA

The nRF5340 has 4 UARTs (with flow control CTS, RTS) on the Application Core and 1 UART (with flow control CTS, RTS) On the Network Core. Can be brought out on any GPIO pins. UARTe features:

- Full duplex operation
- Automatic hardware flow control
- Optional even parity bit checking and generation
- Easy DMA (for reading and writing to and from RAM)
- Upto 1Mbps baud rate. Baud rate accuracy depends on HFCLK source selected.
- Return to IDLE between transactions supported (when using HW flow control)
- One or two stop bits
- Least significant bit (LSB) first
- UART's can be brought out on any GPIOs and independently configurable.

The signaling levels are nominal 0 V and 3.3 V (tracks VDD) and are inverted with respect to the signaling on an RS232 cable.

Two-way hardware flow control is implemented by UART\_RTS and UART\_CTS. UART\_RTS is an output and UART\_CTS is an input. Both are active low.

These signals operate according to normal industry convention. UART\_RX, UART\_TX, UART\_CTS, UART\_RTS are all 3.3 V level logic (tracks VDD). For example, when RX and TX are idle, they sit at 3.3 V (tracks VDD). Conversely for handshaking pins CTS, RTS at 0 V is treated as an assertion.

The module communicates with the customer application using the following signals:

- Port/TxD of the application sends data to the module's UART\_RX signal line
- Port/RxD of the application receives data from the module's UART\_TX signal line

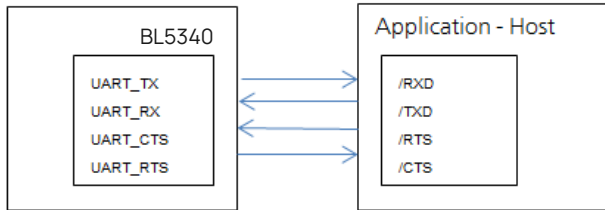

Figure 11: UART signals

**Note:** The BL5340 serial module output is at CMOS logic levels (tracks VDD). Level convertor must be added to interface with an RS-232 level compliant interface.

Some serial implementations link CTS and RTS to remove the need for handshaking. We do not recommend linking CTS and RTS other than for testing and prototyping. If these pins are linked and the host sends data at the point that the BL5340 deasserts its RTS signal, there is significant risk that internal receive buffers will overflow, which could lead to an internal processor crash. This will drop the connection and may require a power cycle to reset the module. We recommend you adhere to the correct CTS/RTS handshaking protocol for proper operation.

Table 14: GPIO used on DVK-BL5340 to bring out UART0 and UART1 interfaces

Signal Name	Pin No	I/O	Comments
P0.20 / UART0_TX	14	O	P0.20 (alternative function UART0_TX) is an output, set high (in firmware). Application Core.
P0.22 / UART0_RX	12	I	GPIO_08 (alternative function UART0_RX) is an input, set with internal pull-up (in firmware). Application Core.
P0.19 / UART0_RTS	15	O	P0.19 (alternative function UART0_RTS) is an output, set low (in firmware). Application Core.
P0.21 / UART0_CTS	11	I	P0.21 (alternative function UART0_CTS) is an input, set with internal pull-down (in firmware). Application Core.
P1.08 / UART1_TX	7	O	P1.08 (alternative function UART1_TX) is an output, set high (in firmware). Network Core.
P1.10 / UART1_RX	57	I	P1.10 (alternative function UART1_RX) is an input, set with internal pull-up (in firmware). Network Core.
P1.07 / UART1_RTS	8	O	P1.07 (alternative function UART1_RTS) is an output, set low (in firmware). Network Core.
P1.09 / UART1_CTS	5	I	P1.09 (alternative function UART1_CTS) is an input, set with internal pull-down (in firmware). Network Core.

The GPIO pins in Table 14 are used for UART0 and UART1 interface as assigned for DVK-BL5340 devboard. UART's can be brought out on any GPIO pin on BL5340 module.

Baud rate accuracy depends on HFCLK source selected.

High baud rates may require GPIOs to be set as High Drive.

## 5.4 USB D – Universal Serial Bus device

BL5340 has USB2.0 FS (Full Speed, 12Mbps) hardware capability.

**Table 15: USB interface**

Signal Name	Pin No	I/O	Comments
D-	42	I/O	
D+	36	I/O	
VBUS	40		<p>To use the BL5340 USB peripheral:</p> <ol style="list-style-type: none"> <li>1) Connect the BL5340 VBUS pin to the external supply within the range 4.35V to 5.5V. When using the BL5340 VBUS pin, you <b>MUST</b> externally fit a 4.7uF to ground. Ensure capacitor value reduction due to DC bias, AC bias, temperature is minimized.</li> <li>2) Connect the external supply to either the VDD (Option 1) or VDD_HV (Option 2) pin to operate the rest of BL5340 module.</li> </ol> <p>When using the BL5340 USB peripheral, the VBUS pin can be supplied from same source as VDD_HV (within the operating voltage range of the VBUS pin and VDD_HV pin).</p> <p>An optional series 4.7Ohms resistor on the USB supply (VBUS) can be fitted for improved immunity to transient over-voltage VBUS connection.</p> <p>If not using USB peripheral, the VBUS pin can be left unconnected.</p>

## 5.5 SPI Master – Serial Peripheral Interface master

The nRF5340 supports 4 x SPI master/slave interface (SPIM /SPIS) with easy DMA (on Application Core) and 1 x SPIM master/slave with easy DMA (on Network Core). For this any GPIO pin can be used.

The nRF5340 supports 1 x High Speed SPI master/slave interface (SPIM4) for the fastest SPIM mode (32Mbps) on the Application Core (when running at 128MHz), For SPIM4, dedicated GPIO pins must be used (see Table 16). SMPIM supports Easy DMA direct transfer to and from RAM.

The SPIM interface enables full duplex synchronous communication between devices. It supports a 3-wire (SPI\_MOSI, SPI\_MISO, SPI\_SCK,) bidirectional bus with fast data transfers to and from multiple slaves and optional D/CX output line for distinguishing between command and data bytes. Individual chip select signals are necessary for each of the slave devices attached to a bus, but control of these is left to the application.

The SPI peripheral supports SPI mode 0, 1, 2, and 3.

**Table 16: High Speed SPI (SPIM4 32Mbps) interface dedicated pins**

Signal Name	Pin No	I/O	Comments
P0.08/SPIM4_SCK	27	O	These dedicated GPIO pins must be used for 32Mbps high speed SPI using SPIM4, and drive strength configuration H0H1 must be used.
P0.09/SPIM4_MOSI	25	O	
P0.10/SPIM4_MISO	22	I	Optional D/CX output line for distinguishing between command and data bytes. The D/CX line is set low during transmission of command bytes and high during transmission of data bytes.
P0.11/SPIM4_CSN	23	O	
P0.12SPIM4_DCX	20	O	

SPI Master (SPIM) maximum bit rate is 16Mbps and this may require GPIO to be set as High Drive strength. Other SPIM bit rates are 8Mbps, 4Mbps, 2Mbps, 1Mbps, 500kbps, 250kbps, 125kbps (and accuracy depends on HFCLK source selected).

High Speed SPIM (SPIM4) is 32Mbps and requires to dedicated GPIO pins (Application core when running at 128MHz). For other lower speed SPI, any GPIO pins can be used.

To secure correct behavior in the pins used by SPIM must be configured in the GPIO peripheral before enabling the SPI slave.

## 5.6 SPI Slave – Serial Peripheral Interface slave

The nRF5340 supports 4 x SPI master/slave interface (SPIM /SPIS) with easy DMA (on Application Core) and 1 x SPIM master/slave with easy DMA (on Network Core). For this any GPIO pin can be used.

SPI slave (SPIS) is implemented for ultra-low power communication from an external SPI master. Easy DMA in conjunction with hardware-based semaphore mechanism removes all real time requirements associated with controlling SPI slave from a low priority CPU execution context.

Maximum SPI bit rate is 8Mbps and the actual maximum data rate depends on the masters CLK to MISO setup and hold timings. Also, this higher SPI bit rate requires GPIO to be set as High Drive strength.

The MISO line is set in high impedance as long as the SPI slave is not selected with CSN.

To secure correct behavior in the slave SPI slave, the pins used by the SPI slave must be configured in the GPIO peripheral before enabling the SPI slave.

## 5.7 QSPI – Quad Serial Peripheral interface

The nRF5340 supports 1 x QSPI interface peripheral (on Application Core) for communicating with external flash memory device. The main features for QSPI peripheral are:-

- Single/dual/quad SPI input/output
- 6 to 96MHz configurable clock frequency
- Single-word read/write access from/to external flash
- Easy DMA for block read and write transfers
- Up to 48MB/sec Easy DMA read rate
- Execute in place (SIP) for executing program directly from external flash
- XIP (Execute in Place) access can be optional be disabled
- On-the-fly encryption and decryption including Easy DMA and XIP

For QSPI only the dedicated GPIO pins from [Table 17](#) shall be used.

**Table 17: QSPI Interface dedicated pins**

Signal Name	Pin No	I/O	Comments
P0.13/QSPI_IO0	24	IO	For QSPI only these dedicated GPIO pins must be used. The GPIO must use the high drive HOH1 (High 0 High 1) configuration. HOH1 is to do with slew rate.
P0.14/QSPI_IO1	62	IO	
P0.15/QSPI_IO2	18	IO	
P0.16/QSPI_IO3	17	IO	
P0.17/QSPI_CLK	16	O	
P0.18/QSPI_CSN	61	O	

For all high-speed signal, the printed circuit board (PCB) layout must ensure that connections are made using short PCB traces.

## 5.8 TWIM – I2C compatible 2-wire interface master

The nRF5340 supports 4 x TWI peripheral (on Application Core and 1 x TWI (on Network Core). The TWI master with Easy DMA (TWIM) is two wire half duplex master which can communicate with multiple slave devices to same bus. Main features of TWIM:

- I2C compatible
- Supported baud rates: 100, 250, 400 and 1000kbps. High bit rates or stronger pull-ups may require GPIOs set as High drive.
- High Speed TWI (1Mbps) is available on dedicated GPIO pins only)
- Support for clock stretching (non I2C compliant)
- EasyDMA

An I2C interface allows multiple masters and slaves to communicate over a shared wired-AND type bus consisting of two lines which normally sit at VDD. The SCL is the clock line which is always sourced by the master and SDA is a bi-directional data line which can be driven by any device on the bus. The protocol makes it possible to interconnect up to 127 individually addressable devices. TWIM is not compatible with CBUS.

**IMPORTANT:** It is essential to remember that pull-up resistors on both SCL and SDA lines are required. The value of the nRF5340 pull up resistor is 13K Ohms typical. For other values, fit external pull-up resistor on both SCL and SDA as per I2C specification to set speed. The I2C specification allows a line capacitance of 400pF.

**Table 18: High speed TWIM (1Mbps) interface dedicated GPIO pins for proper operation**

Signal Name	Pin No	I/O	Comments
P1.02/I2C_SDA	37	I/O	

Signal Name	Pin No	I/O	Comments
P1.03/I2C_SCL	38	I/O	For the fastest TWI 1Mbps mode, the two dedicated high speed TWI pins must be configured and the 20mA open drain driver enabled using the E0E1 drive configuration.  For the dedicated, high-speed TWIM pins on P1.02 and P1.03, the E0E1 drive configuration activates a powerful 20 mA open-drain driver specifically designed for high-speed TWI.

The GPIOs used for each two-wire interface can be chosen from any GPIO device and are independently configurable. This enables great flexibility in device pinout and efficient use of Printed Circuit Board space and signal routing.

To secure correct signal levels on the pins used for TWIM while is System OFF mode and when TWIM is disabled, the pins must be configured as in [Table 19](#).

**Table 19: GPIO configuration before entering peripheral TWIM or TWIS**

Signal Name	Pin No	I/O	Output value	Drive strength
I2C_SDA	As specified in PSEL.SCL	I	Not applicable	S0D1 (Standard 0 Disconnect 1)
I2C_SCL	As specified in PSEL.SDA	I	Not applicable	S0D1 (Standard 0 Disconnect 1)

## 5.9 TWIS – I2C compatible 2-wire interface master

TWI slave with EasyDMA (TWIS) is a two-wire half-duplex slave which can communicate with a master device connected to the same bus. Main features for TWIS:

- I<sup>2</sup>C compatible
- Supported baud rates: 100 and 400 kbps
- EasyDMA

To ensure lowest possible power consumption when the peripheral is not needed stop and disable TWIS.

## 5.10 GPIO – General Purpose Input /Output

The 48 general purpose input /output pins (GPIO) are grouped as 2 ports, P0 port has 32 GPIOs and P1 port has 16 GPIOs. They can be accessed individually. Each has the following user configured features:

- Input/output direction
- Output drive strength (standard drive 0.5 mA or high drive 3mA, 5mA)
- Internal pull-up and pull-down resistors (13 K typical) or no pull-up/down or input buffer disconnect
- Wake-up from high or low-level triggers on all pins including NFC pins (Low power detection of pin state changes is possible when in System ON or System OFF)
- Trigger interrupt on state change on any pin (rising edge, falling edge, any change)

**Note:** When a pin is configured as digital input, care has been taken to minimize increased current consumption when the input voltage is between  $V_{IL}$  and  $V_{IH}$ . However, it is a good practice to ensure that the external circuitry does not drive that pin to levels between  $V_{IL}$  and  $V_{IH}$  for a long period of time.

## 5.11 SAADC – Successive approximation analog-to-digital convertor

The nRF5340 has differential successive approximation register analog to digital convertor (SAADC). Main features of SAADC:

- SAADC on Application Core
- 8/10/12-bit resolution and 14-bit resolution with oversampling
- Multiple analog inputs:
  - AIN0 to AIN7 pins
  - VDD pin
  - VDDHDIV5 (through VDDH pin)
- 8 input channels:

- One channel per singled ended input and two channels per differential input
- Scan mode can be configured with both single ended channels and differential channels
- Each channel can be configured to select any of the above analog inputs
- Full scale input range (0 to VDD)
- Sampling triggered via a task from software or a PPI channel for full flexibility on sample frequency source from low power 32.768kHz RTC or more accurate 1/16MHz timers
- One-shot conversion mode to sample a single channel
- Scan mode to sample a series of channels in sequence with configurable sample delay
- Support for direct sample transfer to RAM using Easy DMA
- Interrupts on single sample and full buffer events
- Sample stored as 16-bit two's compliment values for differential and single ended sampling
- Continuous sampling without the need of an external timer
- Internal resistor string
- On-the-fly limit checking

The ADC can coexist with COMP and other peripherals using one of the AIN0-AIN7 provided these are assigned to different pins. It is not recommended to select the same analog input for both modules.

BL5340 provides access to 8-channel 8/10/12-bit successive approximation ADC in one-shot mode. This enables sampling up to 8 external signals through a front-end MUX. The ADC has configurable input and reference pre-scaling and sample resolution (8, 10, and 12 bit).

**Table 20: Analog interface on dedicated pins**

Signal Name	Pin No	I/O	Comments
P0.04/AIN0 – Analog Input	63	I	This interface is an alternate function on each pin, configurable.
P0.05/AIN1 – Analog Input	46	I	Configurable 8, 10, 12-bit resolution.
P0.06/AIN2 – Analog Input	64	I	14-bit resolution with oversampling
P0.07/AIN3 – Analog Input	65	I	Eight 8/10/12-bit channels on AIN0-AIN7 or VDD or VDDH/5
P0.25/AIN4 – Analog Input	6	I	Configurable pre-scaling of 4, 2, 1, 1/2, 1/3, 1/4, 1/5 1/6
P0.26/AIN5 – Analog Input	2	I	Configurable acquisition time 3uS, 5uS, 10uS, 15uS, 20uS, 40uS.
P0.27/AIN6 – Analog Input	4	I	One-shot mode or Burst mode
P0.28/AIN7 – Analog Input	53	I	Scan mode for multiple channels Single ended or Differential or not connected

## 5.12 COMP – Comparator

The comparator (COMP) compares an input voltage (VIN+) against a second input voltage (VIN-). VIN+ can be derived from an analog input pin (AIN0-AIN7). VIN- can be derived from multiple sources depending on the operation mode of the comparator.

COMP features include:

- Input range from 0V to VDD
- Single-ended mode
  - Fully flexible hysteresis using 64-level reference ladder
- Differential mode
  - Configurable hysteresis
- Reference input (VREF)
  - VDD
  - External reference from AIN0 to AIN7 (between 0V to VDD)
- Three speed/power consumption modes:
  - Low power
  - Normal
  - High speed
- Single pin capacitive sensor support
- Event generation on output changes

## 5.13 LPCOMP – Low power comparator

Low Power comparator (LPCOMP) compares an input voltage against reference voltage.

LCOMP features include:

- 0V – VDD input range
- Ultra low power
- Eight input options (AIN0 to AIN7)
- Reference voltage options:
  - Two external analog reference inputs, or
  - 15-level internal reference ladder (VDD/16)
- Optional hysteresis-enable on input
- Can be used as a wakeup source from SYSTEM OFF mode

## 5.14 PWM – Pulse Width Modulation

The pulse width modulation (PWM) module allows the generation of PWM signals on GPIO. The module implements an up or up and-and-down counter with 4 x PWM channels (on Application Core) that drive assigned 4 x GPIOs. There are 4 x PWM units with Easy DMA.

PWM features include:

- Programmable PWM frequency
  - Prescaler of PWM\_CLK: divide by 1(16MHz), divide by 2(8MHz), divide by 4(4MHz), divide by 8(2MHz), divide by 16(1MHz), divide by 32(500kHz), divide by 64(250kHz), divide by 128(125kHz)
- Up to four PWM channels with individual polarity and duty cycle values
- Edge or center-aligned pulses across PWN channels
- Multiple duty cycle arrays (sequences) defined in RAM
- Autonomous and glitch-free update of duty cycle values directly from memory through Easy DMA (no CPU involvement)
- Change of polarity, duty cycle and base frequency possibly on every PWM period
- RAM sequences can be repeated or connected into loops.

The **PWM output** signal has a frequency and duty cycle property. Frequency is adjustable (up to 16 MHz) and the duty cycle can be set over a range from 0% to 100%.

There is a trade-off between PWM output frequency and resolution.

For example:

- PWM output frequency of 500 kHz (2 uS) results in resolution of 1:2.
- PWM output frequency of 100 kHz (10 uS) results in resolution of 1:10.
- PWM output frequency of 10 kHz (100 uS) results in resolution of 1:100.
- PWM output frequency of 1 kHz (1000 uS) results in resolution of 1:1000.

## 5.15 TIMER – Timer/counter

There are 3 x 32-bit TIMER peripheral with counter mode (on Application Core and Network Core) and is a general-purpose timer allowing time intervals to be defined by user input. It can operate in two modes (Timer mode and Counter mode).

TIMER runs on HFCLK source and includes 4-bit (1/2X) prescaler that can divide the timer input clock from the HFCLK controller. TIMER base frequency is always 16MHz divided by the prescaler value.

In Timer mode, TIMER's internal counter register is incremented by one for every tick of the timer frequency  $f_{\text{TIMER}}$ . The timer frequency is derived from PCLK16M and using value specified in the prescaler register.

$$f_{\text{TIMER}} = 16\text{MHz} / (2^{\text{PRESCALAR}})$$

When  $f_{\text{TIMER}} \leq 1\text{MHz}$ , TIMER uses PCLK1M instead of PCLK16M for reduced power consumption.

In Counter mode, the timer frequency and prescaler are not utilized but the TIMER's internal counter register is incremented by one each time the COUNT Task is triggered.

## 5.16 RTC – Real Timer Counter

There are 2 x 24-bit real timer counter (RTC) on Application Core and 2 x RTC on Network Core. The real time counter (RTC) module provides a generic, low power timer on the low frequency clock source (LFCLK). When started, the RTC will automatically request LFCLK source with RC oscillator if the LFCLK is not already running.

## 5.17 TEMP – Temperature sensor

TEMP sensor in the Network Core.

Main features of TEMP are:

- Temperature range is greater than or equal to operating temperature range of nRF5340 device
- Resolution is 0.25°C degrees
- The on-silicon temperature sensor accuracy is  $\pm 5^{\circ}\text{C}$  (for TEMP sensor range  $-20^{\circ}\text{C}$  to  $+70^{\circ}\text{C}$ )
- The on-silicon temperature sensor accuracy is  $\pm 7^{\circ}\text{C}$  (for TEMP sensor range  $-40^{\circ}\text{C}$  to  $+105^{\circ}\text{C}$ )
- To achieve the measurement accuracy stated, the crystal oscillator must be selected as the HFCLK source
- When the temperature measurement is completed, TEMP analog electronics power down to save power
- TEMP only supports one-shot operation, meaning that every TEMP measurement must be explicitly started
- Time required for temperature measurement 36us typical
- Linearity compensation can be implemented if required by the application

## 5.18 Security/Privacy

nRF5340 contains Arm TrustZone CryptoCell™ -312 security subsystem on the Application Core:

- NIST 800-90B, AIS-31, and FIPS 140-2 compliant random number generator
- AES-128 and 256: ECB, CBC, CMAC/CBC-MAC, CTR, CCM/CCM\*, GCM
- SHA-1, SHA-2 up to 256 bits
- Keyed-hash message authentication code (HMAC)
- RSA public key cryptography with up to 3072-bit key size
- ECC support for most used curves
- Application key management using derived key model

## 5.19 RNG – Random number generator

The Network Core has 1 x Random Number Generator (RNG) that generates true non-deterministic random numbers based on internal thermal noise that are suitable for cryptographic purposes. The RNG does not require a seed value.

## 5.20 I2S – Inter-IC sound interface

The I2S (Inter-IC-Sound Interface) module supports the original two channel I2S format and left or right aligned formats. It implements EasyDMA for sample transfer directly to and from RAM without CPU intervention.

The I2S peripheral main features include:

- Master and Slave mode
- Simultaneous bidirectional (TX and RX) audio streaming
- Original I2S and left or right aligned format
- 32, 24, 16, 8-bit sample width
- Separate sample and word widths
- Low-jitter master clock generator
- Various sample rates

The MCK, SCK, LRCK, SDIN and SDOUT signals associated with the I2S module are mapped to GPIO pins selected when the I2S module is enabled. When a pin is acquired by the I2S module, the direction of the pin (input or output) will be configured automatically and any pin direction setting done in the GPIO module will be overwritten. The directions for the I2S pins is shown in [Table 21](#) and [Table 22](#) below.

To secure correct signal levels on the pins in System OFF mode and when I2S module is disabled, these pins must be configured in the GPIO peripheral directly.

**Table 21: I2S Master interface signals before enabling peripheral**

Signal Name	Pin No	I/O	Output value	Comments
MCK	Any GPIO	O	0	I2S master
LRCK	Any GPIO	O	0	
SCK	Any GPIO	O	0	
SDIN	Any GPIO	I	Not applicable	
SDOUT	Any GPIO	O	0	

**Table 22: I2S Slave interface signals before enabling peripheral**

Signal Name	Pin No	I/O	Output value	Comments
MCK	Any GPIO	O	0	I2S slave
LRCK	Any GPIO	I	Not applicable	
SCK	Any GPIO	I	Not applicable	
SDIN	Any GPIO	I	Not applicable	
SDOUT	Any GPIO	O	0	

## 5.21 PDM – Pulse Density Modulation interface and digital microphones

The pulse density modulation (PDM) module enables input of PDM signals from external audio frontends, such as digital microphones. The PDM peripheral generates the PDM clock and supports single or dual channel (left and right) data input. Data is transferred directly to RAM buffers using EasyDMA.

The PDM peripheral main features include:

- Up to two PDM microphones configured as left/right pair using the same data input
- 16 kHz output sample rate, 16-bit samples
- EasyDMA support for sample buffering
- HW decimation filters
- Selectable ratio of 64 or 80 between PDM\_CLK and output sample rate

**Table 23: PDM interface signals**

Signal Name	Pin No	I/O	Comments
DIN	Any GPIO	I	In Application Core
CLK	Any GPIO	O	

PDM can be configured with a single microphone (mono), or with two microphones. When a single microphone is used, connect the microphone clock to CLK, and data to DIN.

If two microphones are used, one of them has to be set as left, the other as right (L/R pin tied high or to GND on the respective microphone). It is strongly recommended to use two microphones of exactly the same brand and type so that their timings in left and right operation match.

To ensure correct operation in the PDM module, the pins used by PDM module must be configured in the GPIO peripheral before enabling the PDM module. This is to ensure that the pins used by the PDM module are driven correctly if the PDM module itself is temporarily disabled or the device temporarily enters System OFF. This configuration must be retained in the GPIO for the selected I/O's as long as the PDM module is supposed to be connected to an external PDM circuit. Only one peripheral can be assigned to drive a particular GPIO pin at a time. Failing to do so may result in unpredictable behavior.

## 5.22 QDEC – Quadrature decoder

The Quadrature decoded (QDEC) provides buffered decoding of quadrature encoded sensor signals. It is suitable for mechanical and optical sensors. QDEC is a 3-pin interface to the off-module quadrature encoder. There are 2 x QDEC in the Application Core.

The QDEC main features include:

- Sample period and accumulation are configurable to match application requirements
- Decoding of digital waveform from off-chip quadrature encoder
- Sample accumulation eliminating hard real time requirements to be enforced on application
- Optional input debounce filters
- Optional LED output signal for optical encoders

To secure correct behavior in the QDEC the pins used by the QDEC must be configured in the GPIO peripheral as shown in [Table 24](#) before enabling the QDEC. Only one peripheral can be assigned to drive a particular GPIO pin at a time. Failing to do so may result in unpredictable behavior.

**Table 24: QDEC interface signals before enabling peripheral**

Signal Name	Pin No	I/O	Output Value	Comments
Phase A	Any GPIO	I	Not applicable	
Phase B	Any GPIO	I	Not applicable	
LED	Any GPIO	I	Not applicable	

## 5.23 nRESET – pin reset

**Table 25: nRESET pin**

Signal Name	Pin No	I/O	Comments
nRESET	54	I	BL5340 HW reset (active low). The reset pin must be held low (for 0.2uS TBC) to generate a valid reset.  Reset time when using pin reset, depending on pin capacitance. 500nF capacitance on reset pin: 13mS (Typ), 40mS (max), 10uF capacitance on reset pin: 260mS (Typ), 800mS (max), e.g., approximately $t=5RC$ where R is the internal pullup 13K Ohms typical enabled.

A reset in the system is triggered by either a system level or core level reset source. A system level reset will reset all cores. Examples of system level reset are Power-on reset, brownout reset and pin reset. Examples of core level reset are soft reset or lockup will reset either entire core or only part of it. Refer to the nRF5340 datasheet for more details

[https://infocenter.nordicsemi.com/topic/ps\\_nrf5340/keyfeatures\\_html5.html?cp=3\\_0\\_0](https://infocenter.nordicsemi.com/topic/ps_nrf5340/keyfeatures_html5.html?cp=3_0_0)

## 5.24 SWD – Two-wire interface

It is mandatory for the customer to wire out the BL5340 SWD two-wire serial interface on host design for purposes of programming firmware and debug. See **Figure 12**, where the following four lines should be wired out: SWDIO, SWDCLK, GND and VDD).

SWO (P0.11) is a Trace output (called SWO, Serial Wire Output) and is not necessary for programming BL5340 over the SWD interface.

nRESET\_BLE is necessary for programming BL5340 over the SWD interface.

**Table 26: Signals for Firmware and Debug**

Signal Name	Pin No	I/O	Comments
SWDIO	55	I/O	Internal pull-up resistor (13K)
SWDCLK	56	I	Internal pull-down resistor (13K)
nRESET	54	I	Internal pull-up resistor (13K)
GND			
VDD			

The Ezurio development board incorporates an on-board USB-to SWD J-link programmer for this purpose.

The SWD connector MPN is as follows:

**Table 27: SWD Connector MPN**

Reference	Part	Description and MPN (Manufacturers Part Number)
P1	FTSH-105	Header, 1.27mm, SMD, 10-way, FTSH-105-01-L-DV Samtech

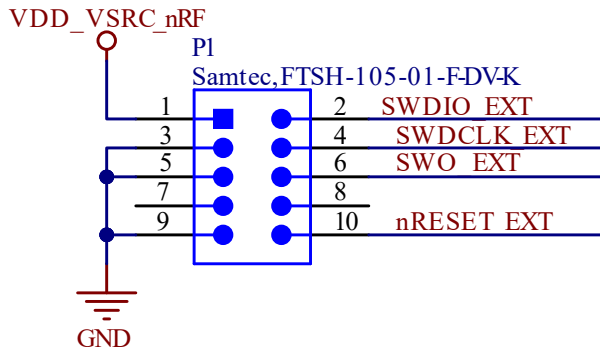

**Figure 12: SWD BL5340 development board schematic**

## 5.25 Peripheral Block Current Consumption

The values below are calculated for a typical operating voltage of 3V (Normal voltage mode).

**Table 28: Common conditions of 3V operating voltage**

Condition	Value	Note
Supply	3V on VDD/VDD_HV(Normal voltage mode)	
Temperature	25°C	
CPU	(WFI(wait for interrupt)/WFE(wait for event) sleep	
Peripherals	All idle	
Clock	HFCLK = HFINT @64MHz, LFCLK=not running	
Regulator	DCDC ON for VREGMAIN, VREGRADIO and VREGH (when used)	
Application core RAM	8kB	In System ON, RAM value refers to the amount of RAM that is switched on. The remainder of RAM is non retained. In System OFF, RAM value refers to amount of RAM that is retained.
Application core RAM	0kB	
Cache enabled	Yes	Only applies when the CPU is running from flash memory.
Network core Forced off	yes	
32MHz crystal	yes	Only applies when the high frequency crystal oscillator (HFXO) is running. HFXO is used when the radio is running
32.768kHz crystal	yes	Only applies when the low frequency crystal oscillator (LFXO) is running.

**Table 29: UART power consumption**

Parameter	Min	Typ		Max	Unit
		WITH DCDC	WITH LDO		
UARTE RX idle (started, waiting for data, no data transfer)	-	645	-	-	uA
UARTE RX idle (started, waiting for data, no data transfer), clock=HFXO64M	-	840	-	-	uA
UART transferring data @ 1200 bps clock=HFXO64M	-	885	-	-	uA
UART transferring data @ 115200 bps clock=HFXO64M	-	890	-	-	uA
UART receiving data @ 115200 bps clock=HFXO64M	-	890	-	-	uA
UART transmitting and receiving data @ 115200 bps clock=HFXO64M	-	895	-	-	uA
UART Baud rate	1	-	-	1000	kbps

**Table 30: SPIM and SPIS power consumption**

Parameter	Min	Typ		Max	Unit
		WITH DCDC	WITH LDO		
SPI Master transferring data @ 2 Mbps	-	935	-	-	uA
SPI Master transferring data @ 2 Mbps, clock=HFXO64M	-	1145	-	-	uA
SPI Master transferring data @ 8 Mbps	-	1705	-	-	uA

Parameter	Min	Typ		Max	Unit
		WITH DCDC	WITH LDO		
SPI Master transferring data @ 8 Mbps, clock=HFXO64M	-	1930	-	-	uA
SPI Master transferring data @ 32 Mbps	-	2115	-	-	uA
SPI Master transferring data @ 32 Mbps, clock=HFXO64M	-	2345	-	-	uA
SPIS configured and idle (enabled, no CSN activity)	-	145	-	-	uA
SPIS transferring data @ 2Mbps	-	713	-	-	uA
SPIS transferring data @ 2 Mbps, clock=HFXO64M	-	913	-	-	uA

**Table 31: TWIM and TWIS (I2C) power consumption**

Parameter	Min	Typ		Max	Unit
		WITH DCDC	WITH LDO		
TWIM transferring data @100kbps	-	965	-	-	uA
TWIM transferring data @100kbps, clock=HFXO64M	-	1170	-	-	uA
TWIM transferring data @400kbps	-	1000	-	-	uA
TWIM transferring data @400kbps, clock=HFXO64M	-	1250	-	-	uA
TWIM transferring data @1000kbps	-	2050	-	-	uA
TWIM transferring data @1000kbps, clock=HFXO64M	-	2295	-	-	uA
TWIS configured and enabled (IDLE state)	-	45	-	-	uA
TWIS transferring data @100kbps	-	945	-	-	uA
TWIS transferring data @400kbps	-	985	-	-	uA
TWIS transferring data @100kbps, clock=HFXO64M	-	1150	-	-	uA
TWIS transferring data @400kbps, clock=HFXO64M	-	1185	-	-	uA

**Table 32: ADC power consumption**

Parameter	Min	Typ		Max	Unit
		WITH DCDC	WITH LDO		
ADC current during conversion SAADC sampling @16ksps, acquisition time =20uS, clock HFXO	-	980	-	-	uA
SAADC sampling @1kHz from RTC intask mode, LPOP=Lowlat, acquisition time =20uS, clock HFINT64M and LFXO	-	770	-	-	uA
SAADC sampling @1kHz from RTC in task mode, LPOP=LowPower, acquisition time =20uS, clock HFINT64M and LFXO	-	160	-	-	uA

**Table 33: COMP and LCOMP power consumption**

Parameter	Min	Typ		Max	Unit
		WITH DCDC	WITH LDO		
COMP enabled, Low power mode	-	60	-	-	uA
COMP enabled, normal power mode	-	62	-	-	uA
COMP enabled, High power mode	-	68	-	-	uA
LCOMP enabled	-	45	-	-	uA

**Table 34: QSPI power consumption**

Parameter	Min	Typ		Max	Unit
		WITH DCDC	WITH LDO		
QSPI idle (enabled, but not activated)	-	45	-	-	uA
QSPI active (activated, but not transferring data)	-	1790	-	-	uA
QSPI active (activated and transferring data to /from external flash memory), SCKFREQ=96MHz, quad mode, clock=HFXO192M	-	4430	-	-	uA

**Table 35: NFC power consumption**

Parameter	Min	Typ		Max	Unit
		WITH DCDC	WITH LDO		
System ON, current in SENSE STATE (this current does not apply when in NFC field)	-	1.3	-	-	uA
System ON, current in ACTIVATED STATE, clock=HFXO64M	-	1080	-	-	uA

**Table 36: PWM power consumption**

Parameter	Min	Typ		Max	Unit
		WITH DCDC	WITH LDO		
PWM running at 125kHz, top=10, duty=50%	-	560	-	-	uA
PWM running at 16MHz, top=10, duty=50%	-	560	1035	-	uA
PWM running at 125kHz, top=10, duty=50%, clock=HFXO64M	-	750	-	-	uA
PWM running at 16MHz, top=10, duty=50%, clock=HFXO64M	-	755	-	-	uA

**Table 37: TIMER power consumption**

Parameter	Min	Typ		Max	Unit
		WITH DCDC	WITH LDO		
One TIMER running @1MHz	-	475	-	-	uA
One TIMER running @1MHz, clock=HFXO64M	-	670	-	-	uA
One TIMER running @16MHz	-	560	1040	-	uA
One TIMER running @16MHz, clock=HFXO64M	-	750	1280	-	uA
One TIMER running @16MHz, clock=HFINT28M	-	750	-	-	uA
One network TIMER running @1MHz	-	170	-	-	uA
One network TIMER running @1MHz, clock=HFXO64M	-	400	-	-	uA
One network TIMER running @16MHz	-	220	-	-	uA

**Table 38: WDT power consumption**

Parameter	Min	Typ		Max	Unit
		WITH DCDC	WITH LDO		
Application MCU WDT started	-	2.0	4.9	-	uA
Network MCU started, 64kB network RAM	-	3.2	-	-	uA

**Table 39: TEMP Power Consumption**

Parameter	Min	Typ		Max	Unit
		WITH DCDC	WITH LDO		
TEMP started, 64kB network RAM	-	615	-	-	uA

**Table 40: RNG power consumption**

Parameter	Min	Typ		Max	Unit
		WITH DCDC	WITH LDO		
RNG running, 64kB network RAM	-	270	-	-	uA

**Table 41: QDEC power consumption**

Parameter	Min	Typ		Max	Unit
		WITH DCDC	WITH LDO		
QDEC running	-	460	-	-	uA

**Table 42: PDM power consumption**

Parameter	Min	Typ		Max	Unit
		WITH DCDC	WITH LDO		
PDM receiving and processing data @1Msps (RATIO=64, PDMCLKCTRL=135274496), stereo mode, clock=HFXO64M	-	655	-	-	uA
PDM receiving and processing data @1Msps (RATIO=64, PDMCLKCTRL=3435997056), stereo mode, clock=HFXO64M	-	1045	-	-	uA

**Table 43: I2S power consumption**

Parameter	Min	Typ		Max	Unit
		WITH DCDC	WITH LDO		
I2S transferring data @ 2x16bitx16kHz (CONFIG.MCKFREQ=32MDIV63, CONFIG.RATIO=32X), clock=HFXO64M	-	2000	-	-	uA
I2S transferring data @ 2x16bitx16kHz (CONFIG.MCKFREQ=510000, CONFIG.RATIO=32X), clock=HFXO ACLK@12.288MHz	-	2170	-	-	uA
I2S transferring data @ 2x16bitx48kHz (CONFIG.MCKFREQ=505286656, CONFIG.RATIO=32X), clock=HFXO ACLK@12.288MHz	-	2310	-	-	uA

**Table 44: USB active power consumption**

Parameter	Min	Typ		Max	Unit
		WITH DCDC	WITH LDO		
Current from VBUS supply, USB active	-	1.2	-	-	uA
Current from VBUS supply, USB suspended, CPU sleeping	-	180	-	-	uA
Current from VDD supply (normal voltage mode), all RAM retained, CPU running, USB active	-	3.0	-	-	uA
Current from VDD supply (normal voltage mode), all RAM retained, CPU running, USB suspended	-	815	-	-	uA
Current from VDD supply (normal voltage mode), all RAM retained, CPU sleeping, USB suspended, regulator = LDO	-	135	-	-	uA
Current from VDDH supply (high voltage mode), VDD=3 V (VREGH output), all RAM retained, CPU running, USB active	-	3.2	-	-	uA
Current from VDDH supply (high voltage mode), VDD=3 V (VREGH output), all RAM retained, CPU sleeping, USB suspended	-	2340	-	-	uA
Current from VDDH supply (high voltage mode), VDD=3 V (VREGH output), all RAM retained, CPU sleeping, USB suspended, regulator = LDO	-	125	-	-	uA
Current from VDD supply, USB disabled, VBUS supply connected, all RAM retained, CPU sleeping	-	3	-	-	uA

The above current consumption is for the given peripheral including the internal blocks that are needed for that peripheral for both the case when DCDC is on and off. The peripheral Idle current is when the peripheral is enabled but not running (not sending data or being used) and must be added to the System ON Idle current. In all cases radio is not turned on.

For asynchronous interface, like the UART (asynchronous as the other end can communicate at any time), the UART on the BL5340 must be kept open, resulting in the base current consumption penalty.

For a synchronous interface like the I2C or SPI (since BL5340 side is the master), the interface can be closed and opened when needed, resulting in current saving (no base current consumption penalty). There's a similar argument for ADC (open ADC when needed).

## 5.26 453-00052 On-Board PCB Trace Antenna Characteristics

The 453-00052 on-board PCB trace monopole antenna radiated performance depends on the host PCB layout.

The BL5340 development board was used for BL5340 development and the 453-00052 PCB antenna performance evaluation. To obtain similar performance, follow guidelines in section 8.2 Host PCB Land Pattern and Antenna Keep-out for the 453-00052 to allow the on-board PCB antenna to radiate and reduce proximity effects due to nearby host PCB GND copper or metal covers.

Antenna Efficiency	2402MHz		2440MHz		2480MHz	
	Peak	Avg	Peak	Avg	Peak	Avg
453-00052 PCB trace antenna	+0.2dBi	-4.24dBi	+1.49dBi	-3.19dBi	+1.39dBi	-3.27dBi

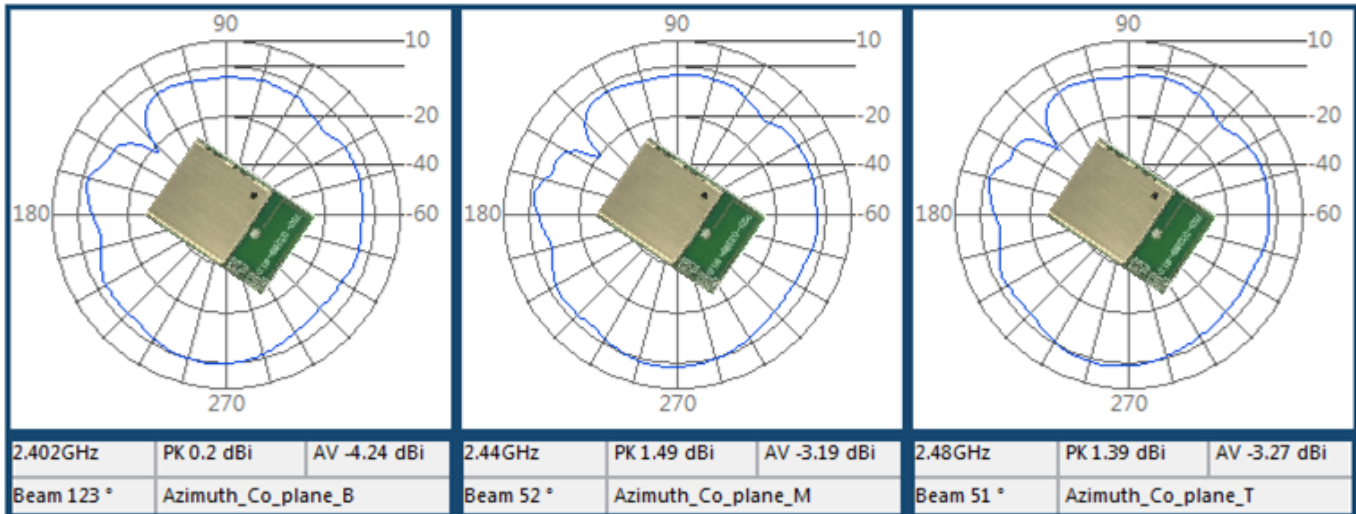

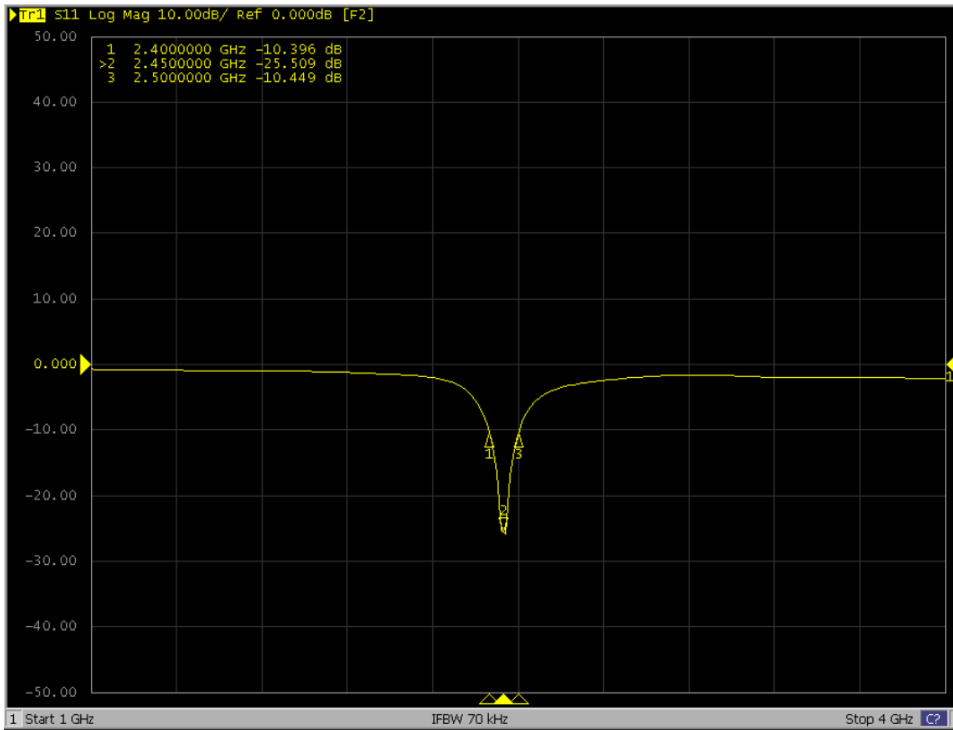

Figure 13: 453-00052 on-board PCB antenna performance (Antenna Gain and S11 – whilst 453-00052 module sitting on Devboard 453-00052-K1)

## 6 Mandatory SW requirements related to hardware

### 6.1 32MHz crystal internal load capacitor setting of 13.5pF

MANDATORY. BL5340 module contains the 32 MHz crystal but the load capacitors to create 32 MHz crystal oscillator circuit are inside the nRF5340 chipset. Customer MUST set the internal nRF5340 capacitors to 13.5 pF (for proper operation of the 32 MHz crystal circuit in the BL5340 module).

### 6.2 CH26 (2480MHz) IEEE 802.15.4-2006 RF TX power

MANDATORY. When used in IEEE 802.15.4-2006 PHY mode, channel 26 (2480MHz), the BL5340 RF TX power must be limited by customer to -8 dBm setting (which produces -5dBm with VREQCTRL ON) maximum RF transmit power to pass FCC/IC Band Edge emissions limit. All other 802.15.4 channels (11-25) may be used up to the maximum 0dBm (which produces +3 dBm with VREQCTRL ON) RF TX output power.

## 7 Hardware Integration Suggestions

### 7.1 Circuit

The BL5340 is easy to integrate, requiring no external components on your board apart from those which you require for development and in your end application.

The following are suggestions for your design for the best performance and functionality.

#### Checklist (for Schematic):

- **BL5340 power supply options:**

**Option 1** – Normal voltage power supply mode entered when the external supply voltage is connected to both the VDD and VDDH pins (so that VDD equals VDD\_HV). Connect external supply within range 1.7V to 3.6V range to BL5340 VDD and VDD\_HV pins.

OR

**Option 2** – High voltage mode power supply mode (using BL5340 VDD\_HV pin) entered when the external supply voltage is ONLY connected to the VDD\_HV pin and the VDD pin is not connected to any external voltage supply. Connect external supply within range 2.5V to 5.5V range to BL5340 VDD\_HV pin. BL5340 VDD pin left unconnected.

External power source should be within the operating range, rise time and noise/ripple specification of the BL5340. Add decoupling capacitors for filtering the external source. Power-on reset circuitry within BL5340 series module incorporates brown-out detector, thus simplifying your power supply design. Upon application of power, the internal power-on reset ensures that the module starts correctly.

- **BL5340 USB peripheral:**

To use the BL5340 USB peripheral:

1. Connect the BL5340 VBUS pin to the external supply within the range 4.35V to 5.5V. When using the BL5340 VBUS pin, you **MUST** externally fit a 4.7uF to ground. Ensure capacitor value reduction due to DC bias, AC bias, temperature is minimized.
2. Connect the external supply to either the VDD (Option 1) or VDD\_HV (Option 2) pin to operate the rest of BL5340 module.

When using the BL5340 USB peripheral, the VBUS pin can be supplied from same source as VDD\_HV (within the operating voltage range of the VBUS pin and VDD\_HV pin).

An optional series 4.70ohms resistor on the USB supply (VBUS) can be fitted for improved immunity to transient over-voltage VBUS connection.

If not using USB peripheral, the VBUS pin can be left unconnected.

- **AIN (ADC) and GPIO pin IO voltage levels**

BL5340 GPIO voltage levels are at VDD. Ensure input voltage levels into GPIO pins are at VDD also (if VDD source is a battery whose voltage drops). Ensure ADC pin maximum input voltage for damage is not violated.

- **AIN (ADC) impedance and external voltage divider setup**

If you need to measure with ADC a voltage higher than 3.6V, you can connect a high impedance voltage divider to lower the voltage to the ADC input pin.

- **SWD**

This is REQUIRED for loading firmware. MUST wire out the SWD two wire interface on host design (see [Figure 12](#)). Five lines should be wired out, namely SWDIO, SWDCLK, nRESET, GND and VDD.

- **UART and flow control (CTS, RTS)**

Required if customer requires UART.

- **TWI (I2C)**

It is essential to remember that pull-up resistors on both SCL and SDA lines are required, the value as per I2C standard. nRF5340 can provide 13K Ohms typical pull up values internally. For other values, fit external pull-up resistor on both SCL and SDA as per I2C specification to set speed. The I2C specification allows a line capacitance of 400pF.

- **QSPI, High Speed SPI (SPIM4, 32Mbps), High speed TWI (I2C, 1Mbps), QSPI and Trace**

QSPI, High-Speed SPI (SPIM4) 32Mbps, TWI 1Mbps and Trace come on dedicated GPIO pins only. Other lower speed SPI and TWI can come out on any GPIO pins.

For all high-speed signal, the printed circuit board (PCB) layout must ensure that connections are made using short PCB traces.

- **GPIO pins**

If GPIO is selected as an input, ensure the input is not floating (which can cause current consumption to drive with time in low power modes (such as System ON Idle), by selecting the internal pull up or pull down.

- **NFC antenna connector**

To make use of the Ezurio flexi-PCB NFC antenna, fit connector:

- Description – FFC/FPC Connector, Right Angle, SMD/90d, Dual Contact, 1.2 mm Mated Height
- Manufacturer – Molex
- Manufacturers Part number – 512810594

Add tuning capacitors of 300 pF on NFC1 pin to GND and 300 pF on NFC2 pins to GND if the PCB track length is similar as development board.

- **nRESET pin (active low)**

Hardware reset. Wire out to push button or drive by host.

By default module is out of reset when power applied to VDD pins (13K pull-up inside nRF5340).

- **Optional External 32.768kHz crystal**

If the optional external 32.768kHz crystal is needed, then use a crystal that meets specification and add load capacitors (either inside nRF5340 or discrete capacitors outside nRF53) whose values should be tuned to meet all specification for frequency and oscillation margin.

- **BL5340 module RF pad variant (453-00053)**

RF\_pad (pin72) is for the BL5340 RF pad variant (453-00053) module only. If using the BL5340 module RF pad variant (453-00053), customer MUST copy the 50-Ohms GCPW RF track design, MUST add series 2nH RF inductor (Murata LQG15HN2N0B02# or Murata LQG15HS2N0B02) and RF connector IPEX MHF4 Receptacle (MPN: 20449-001E) Detailed in the following section:

[7.4 50-Ohms RF Trace and RF Match Series 2nH RF inductor on Host PCB for BL5340 RF pad variant \(453-00053\)](#)

## 7.2 PCB Layout on Host PCB - General

### Checklist (for PCB):

- MUST locate BL5340 module close to the edge of PCB (mandatory for the 453-00052 for on-board PCB trace antenna to radiate properly).
- Use solid GND plane on inner layer (for best EMC and RF performance).
- All module GND pins MUST be connected to host PCB GND.
- Place GND vias close to module GND pads as possible.
- Unused PCB area on surface layer can be flooded with copper but place GND vias regularly to connect the copper flood to the inner GND plane. If GND flood copper is on the bottom of the module, then connect it with GND vias to the inner GND plane.
- Route traces to avoid noise being picked up on VDD, VDDH, VBUS supply and AIN (analogue), GPIO (digital) traces and high-speed traces.
- Ensure no exposed copper is on the underside of the module (refer to land pattern of BL5340 development board).

## 7.3 PCB Layout on Host PCB for the 453-00052

### 7.3.1 Antenna Keep-out on Host PCB

The 453-00052 has an integrated PCB trace antenna and its performance is sensitive to host PCB. It is critical to locate the 453-00052 on the edge of the host PCB (or corner) to allow the antenna to radiate properly. Refer to guidelines in section **PCB land pattern and antenna keep-out area for the 453-00052**. Some of those guidelines repeated below.

- Ensure there is no copper in the antenna keep-out area on any layers of the host PCB. Keep all mounting hardware and metal clear of the area to allow proper antenna radiation.
- For best antenna performance, place the 453-00052 module on the edge of the host PCB, preferably in the edge center.
- The BL5340 development board (453-00052-K1) has the 453-00052 module on the edge of the board (not in the corner). The antenna keep-out area is defined by the BL5340 development board which was used for module development and antenna performance evaluation is shown in **Figure 14**, where the antenna keep-out area is ~4.7 mm wide, ~39.17 mm long; with PCB dielectric (no copper) height ~1 mm sitting under the 453-00052 PCB trace antenna.
- The 453-00052 PCB trace antenna is tuned when the 453-00052 is sitting on development board (host PCB) with size of 135 mm x 110 mm x 1mm.
- A different host PCB thickness dielectric will have small effect on antenna.
- The antenna-keep-out defined in the **8.2 Host PCB Land Pattern and Antenna Keep-out for the 453-00052** section.
- Host PCB land pattern and antenna keep-out for the BL5340 applies when the 453-00052 is placed in the edge of the host PCB preferably in the edge center. **Figure 14** shows an example.

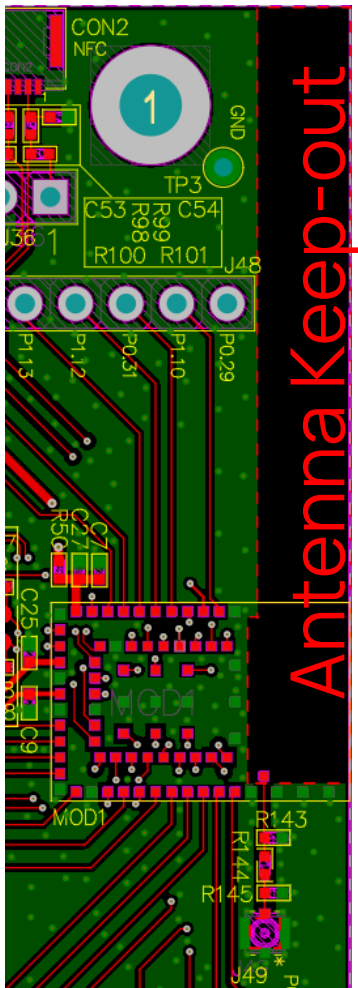

Figure 14: PCB trace Antenna keep-out area (shown in red), corner of the BL5340 development board for the 453-00052 module.

**Antenna Keep-out Notes:**

<b>Note 1</b>	The BL5340 module is placed on the edge, preferably edge centre of the host PCB.
<b>Note 2</b>	Copper cut-away on all layers in the <i>Antenna Keep-out</i> area under the 453-00052 on host PCB.

**7.3.2 Antenna Keep-out and Proximity to Metal or Plastic**

**Checklist (for metal /plastic enclosure):**

- Minimum safe distance for metals without seriously compromising the antenna (tuning) is 40 mm top/bottom and 30 mm left or right.
- Metal close to the 453-00052 PCB trace monopole antenna (bottom, top, left, right, any direction) will have degradation on the antenna performance. The amount of that degradation is entirely system dependent, meaning you will need to perform some testing with your host application.
- Any metal closer than 20 mm will begin to significantly degrade performance (S11, gain, radiation efficiency).
- It is best that you test the range with a mock-up (or actual prototype) of the product to assess effects of enclosure height (and materials, whether metal or plastic) and host PCB ground (GND plane size).

**7.4 50-Ohms RF Trace and RF Match Series 2nH RF inductor on Host PCB for BL5340 RF pad variant (453-00053)**

To use an external antenna requires BL5340 module variant with RF pad (453-00053) and 50-Ohm RF trace (GCPW, that is Grounded Coplanar Waveguide) from RF\_pad (pin72) of the module (BL5340 453-00053) to RF antenna connector (IPEX MHF4) on host PCB. On this RF path, MUST use 2nH series RF inductor. BL5340 module GND pin1 and GND pin3 used to support GCPW 50-Ohm RF trace.

**Checklist for SCH**

- MUST fit 2 nH RF inductor (R144) in series. RF inductor part number is Murata LQG15HN2N0B02# or Murata LQG15HS2N0B02# with 0402 body size.  
<https://www.murata.com/en-eu/products/productdetail.aspx?partno=LQG15HN2N0B02%23>  
<https://www.murata.com/en-eu/products/productdetail.aspx?partno=LQG15HS2N0B02%23>
- MUST fit RF connector IPEX MHF4 Receptacle (MPN: 20449-001E), <https://www.i-pex.com/product/mhf-4-smt#!>

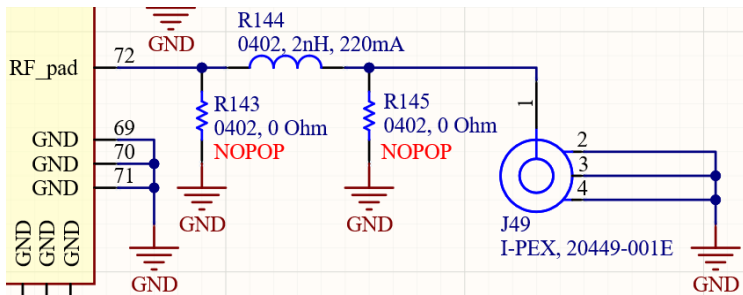
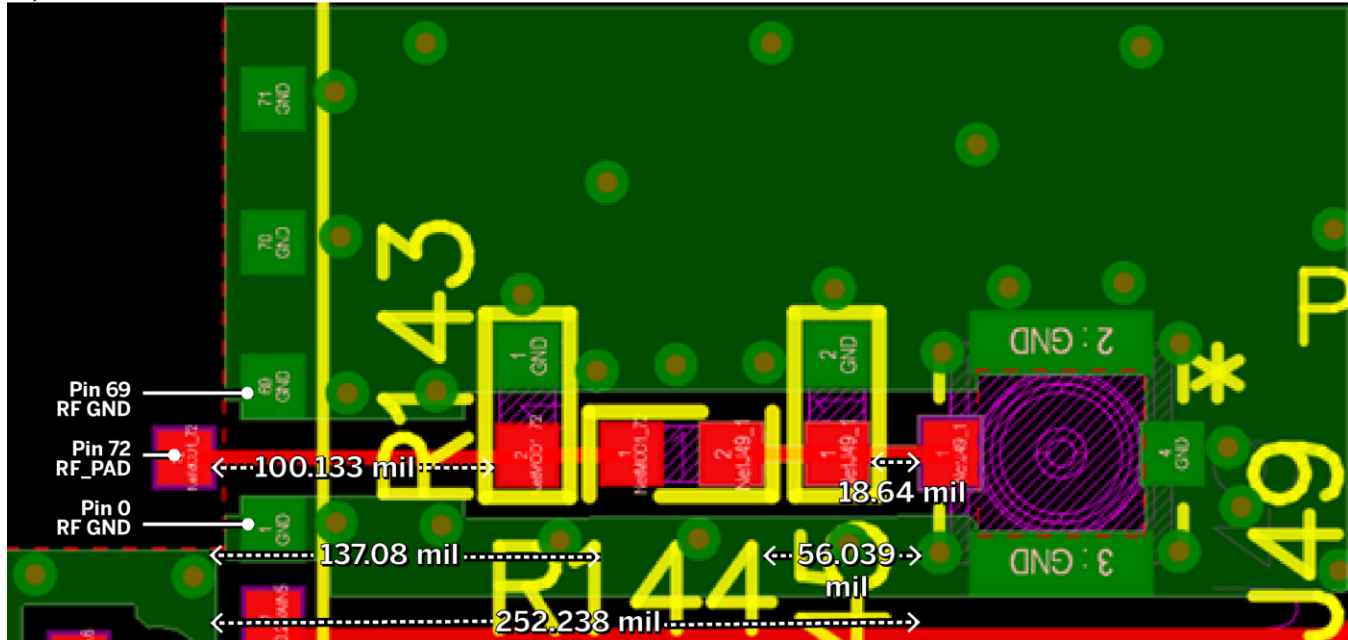

Figure 15: BL5340 RF pad variant (453-00053) Host PCB 50-Ohm RF trace schematic with series 2nH inductor, RF connector

Layer1 (RF Track and RF GND)



Layer2 (RF GND) and Layer2 copper cut-out under RF connector

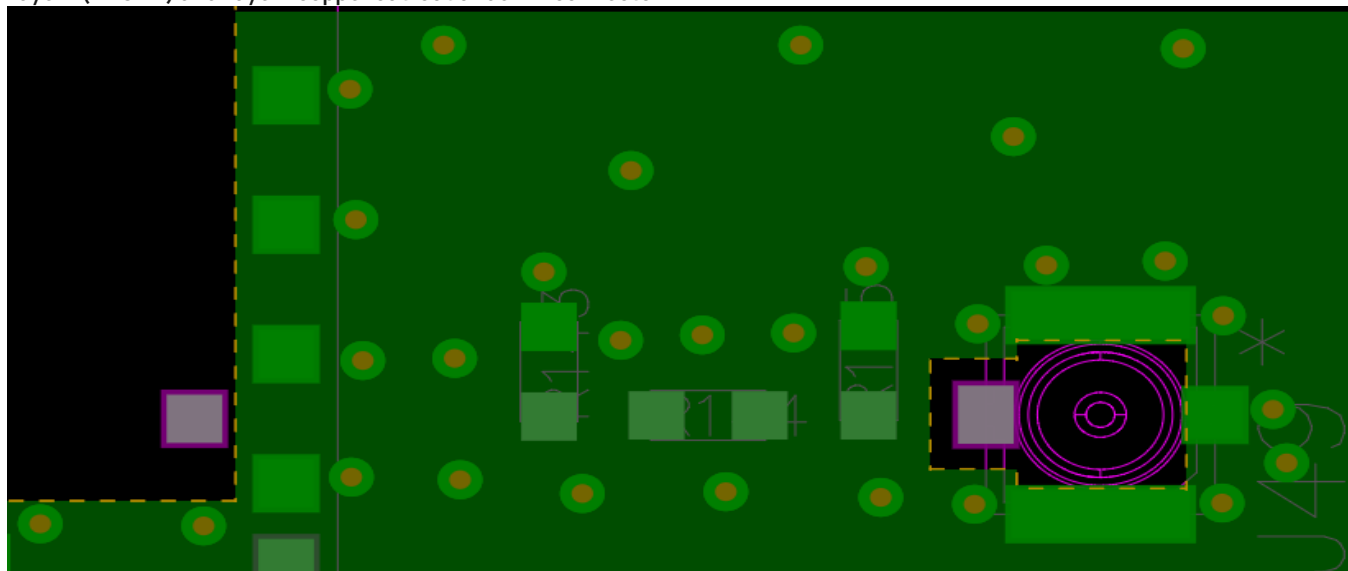
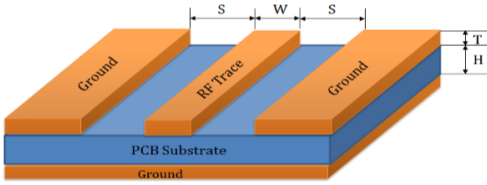

Figure 16: 50-Ohm RF trace design (Layer1 and Layer2) on BL5340 development board (or host PCB) for use with BL5340 (453-00053) module

**Checklist for PCB:**

- MUST use a 50-Ohm RF trace (GCPW, that is Grounded Coplanar Waveguide) from RF\_pad (pin72) of the module (BL5340 453-00053) to RF antenna connector (IPEX MHF4) on host PCB.
- To ensure regulatory compliance, MUST follow exactly the following considerations for 50-Ohms RF trace design and test verification:



	Thickness	Dielectric	
	mil	Constant Er	
Solder Mask	0.4	3.5	Stack up for 50 Ohms GCPW RF track.
Layer1 Copper 0.5 oz+plating (Note1)	1.3		
Prepreg (2113)	3.8	4.1	
Layer2 Copper 1 oz	1.2		
Core 0.6 mm	23.62	4.52	
Layer3 Copper 1 oz	1.2		
Prepreg (2113)	3.8	4.1	
Layer1 Copper 0.5 oz+plating	1.3		
Solder Mask	0.4	3.5	

**Figure 17: BL5340 development board PCB stack-up and L1 to L2 50-Ohms Grounded CPW RF trace design**

**Note 1:** The plating (ENIG) above base 0.5 oz copper is not listed, but plating expected to be ENIG.

- The 50-Ohms RF trace design MUST be Grounded Coplanar Waveguide (GCPW) with
  - Layer1 RF track width (W) of 6.0 mil and
  - Layer1 gap (G) to GND of 10 mil and where the
  - Layer1 to Layer 2 dielectric thickness (H) MUST be 3.8 mil (dielectric constant Er 4.1).
  - Further the Layer1 base copper must be 0.5-ounce base copper (that is 0.7 mil) plus the plating and
  - Layer1 MUST be covered by solder mask of 0.4 mil thickness (dielectric constant Er 3.5).
- The 50-Ohms RF trace design MUST follow the PCB stack-up shown in **Figure 17**. (Layer1 to Layer2 thickness MUST be identical to the BL5340 development board).
- The 50-Ohms RF track should be a controlled-impedance trace e.g., ±10%.
- The 50-Ohms RF trace length MUST be identical (as seen in **Figure 16**) (252.238mil) to that on the BL5340 development board from BL5340 module RF pad (pin72) to the RF connector IPEX MHF4 Receptable (MPN: 20449-001E).
- Place GND vias regularly spaced either side of 50-Ohms RF trace to form GCPW (Grounded coplanar waveguide) transmission line as shown in **Figure 16** and use BL5340 module GND pin1 and GND pin69.
- Cut away copper on Layer2 GND layer under the RF connector IPEX MHF4 Receptable, as seen in **Figure 16**. This is to reduce RF detuning the 50Ohms of the RF connector (J49) when it sits on the PCB.
- Cut away copper on Layer2 GND layer under the BL5340 module RF pad (pin72), identical to the BL5340 development board as seen in **Figure 16**.
- Use spectrum analyzer to confirm the radiated (and conducted) signal is within the certification limit.

## 7.5 External Antenna Integration with the 453-00052

Please refer to the regulatory sections for FCC, ISED, CE, MIC, UKCA and RCM details of use of BL5340 with external antennas in each regulatory region.

The BL5340 family has been designed to operate with the below external antennas (with a maximum gain of 2.0 dBi). The required antenna impedance is 50 ohms. See [Table 45](#). External antennas improve radiation efficiency.

**Table 45: External antennas for the BL5340**

Manufacturer	Model	Ezurio Part Number	Type	Connector	Peak Gain	
					2400-2500 MHz	2400-2480 MHz
Ezurio (Laird Connectivity)	NanoBlue	EBL2400A1-10MH4L	PCB Dipole	IPEX MHF4	2 dBi	-
Ezurio (Laird Connectivity)	FlexPIFA	001-0022	PIFA	IPEX MHF4	-	2 dBi
Mag.Layers	EDA-8709-2G4C1-B27-CY	0600-00057	Dipole	IPEX MHF4	2 dBi	-
Ezurio (Laird Connectivity)	mFlexPIFA	EFA2400A3S-10MH4L	PIFA	IPEX MHF4	-	2 dBi
Ezurio (Laird Connectivity)	Laird Connectivity NFC	0600-00061	NFC	N/A	-	-

## 8 Mechanical Details

### 8.1 BL5340 Mechanical Details

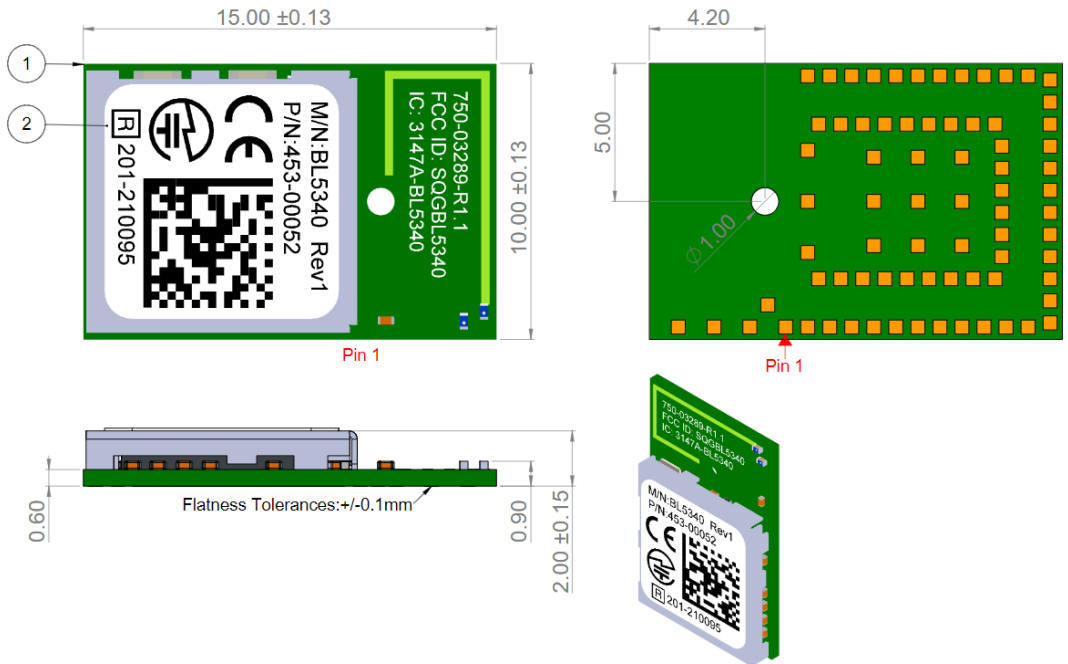

Figure 18: Mechanical Details - Chip Antenna

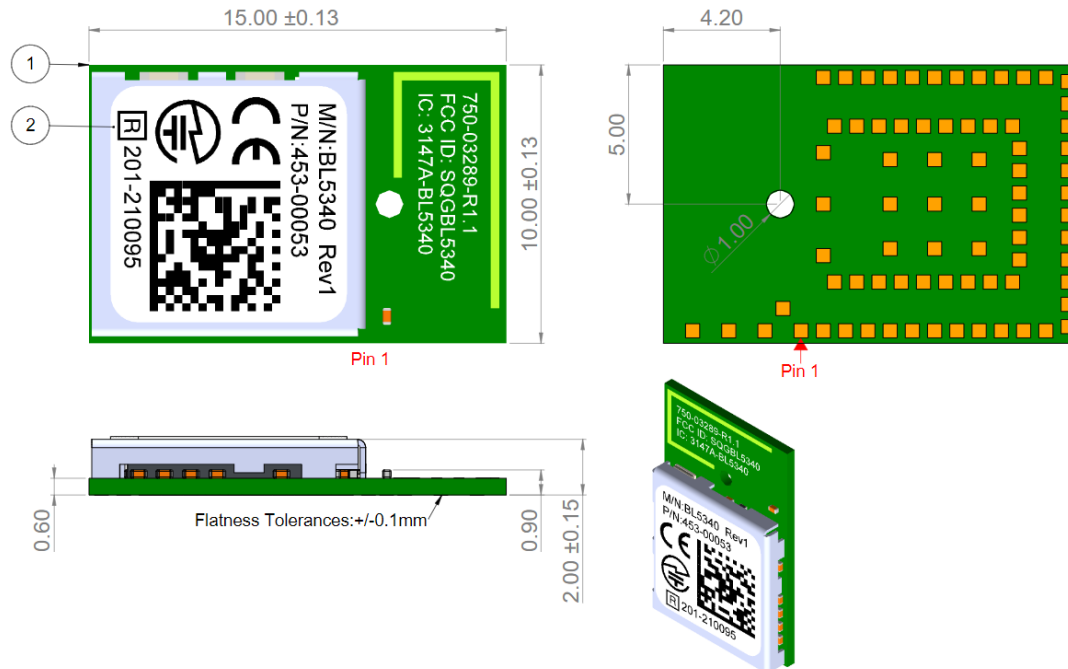
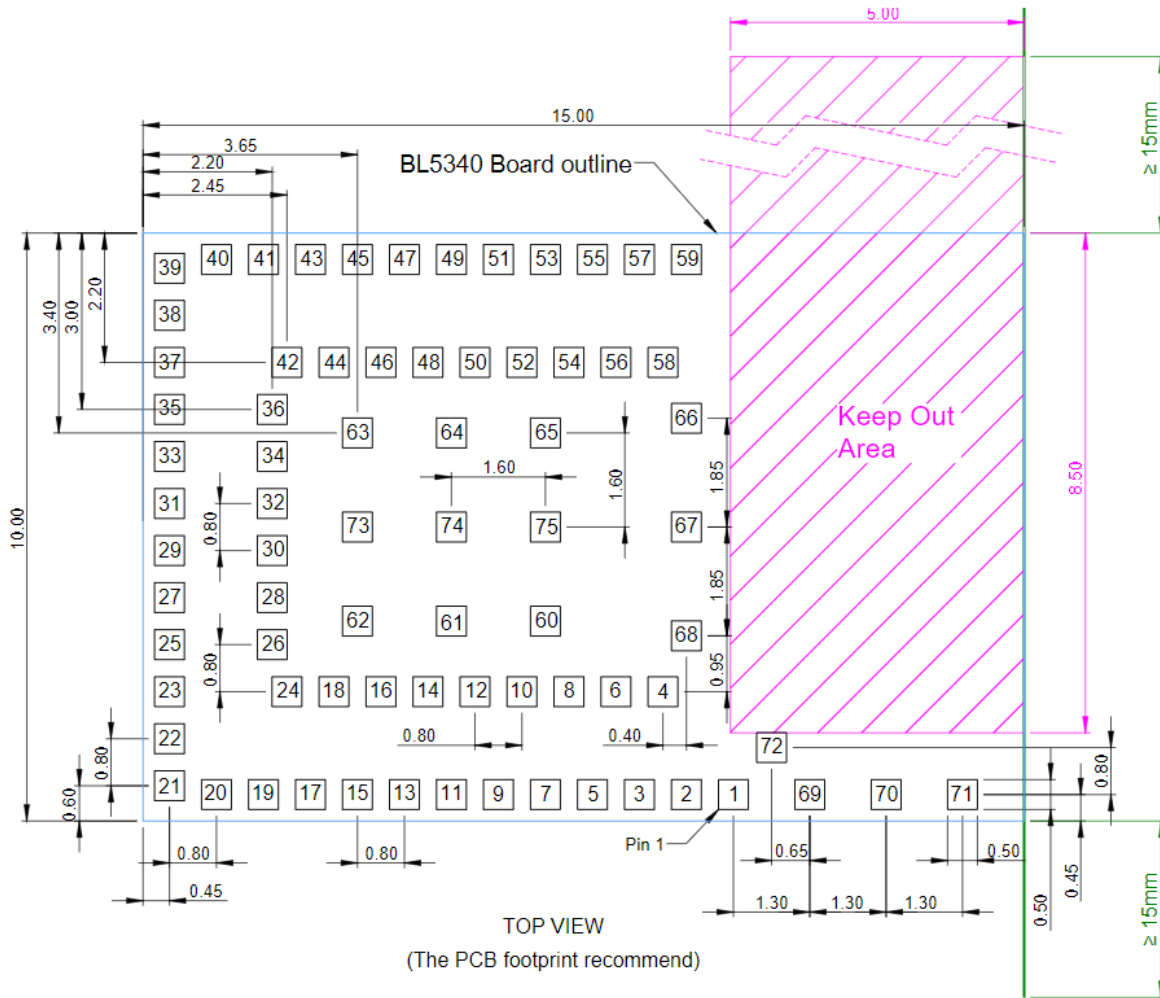

Figure 19: Mechanical Details - Trace Pin

3D models for External Antenna Trace Pin and Internal Antenna, SCH symbols (Altium format), PCB footprints (DXF and Altium format) and Development Kit Schematics can be found on the BL5340 product page - <http://ezurio.com/bl5340-series>

## 8.2 Host PCB Land Pattern and Antenna Keep-out for the 453-00052

SCH symbols (Altium format) and PCB footprints (DXF and Altium format) can be found on the BL5340 product page – <http://ezurio.com/bl5340-series>



All dimensions are in mm.

Figure 20: Land pattern and Keep-out for the 453-00052

### Host PCB Land Pattern and Antenna Keep-out for the 453-00052 Notes:

<b>Note 1</b>	Ensure there is no copper in the antenna 'keep out area' on any layers of the host PCB. Also keep all mounting hardware or any metal clear of the area (Refer to 7.3.2) to reduce effects of proximity detuning the antenna and to help antenna radiate properly.
<b>Note 2</b>	For the best on-board antenna performance, the module 453-00052 MUST be placed on the edge of the host PCB and preferably in the edge centre and host PCB, the antenna "Keep Out Area" is extended (see Note 4).
<b>Note 3</b>	BL5340 development board has the 453-00052 placed on the edge of the PCB board (and not in corner) for that the Antenna keep out area is extended down to the corner of the development board, see section 8.2 Host PCB Land Pattern and Antenna Keep-out for the 453-00052.
<b>Note 4</b>	Ensure that there is no exposed copper under the module on the host PCB.
<b>Note 5</b>	You may modify the PCB land pattern dimensions based on their experience and/or process capability.

## 9 Application Note for Surface Mount Modules

### 9.1 Introduction

Ezurio surface mount modules are designed to conform to all major manufacturing guidelines. This application note is intended to provide additional guidance beyond the information that is presented in the User Manual. This Application Note is considered a living document and will be updated as new information is presented.

The modules are designed to meet the needs of several commercial and industrial applications. They are easy to manufacture and conform to current automated manufacturing processes.

### 9.2 Shipping

#### 9.2.1 Tape and Reel Package Information

**Notes:**

- All dimensions are in millimeters.
- Material is High Impact Polystyrene (HIPS)
- Surface resistivity  $10^7 \sim 10^{11} \Omega/\square$

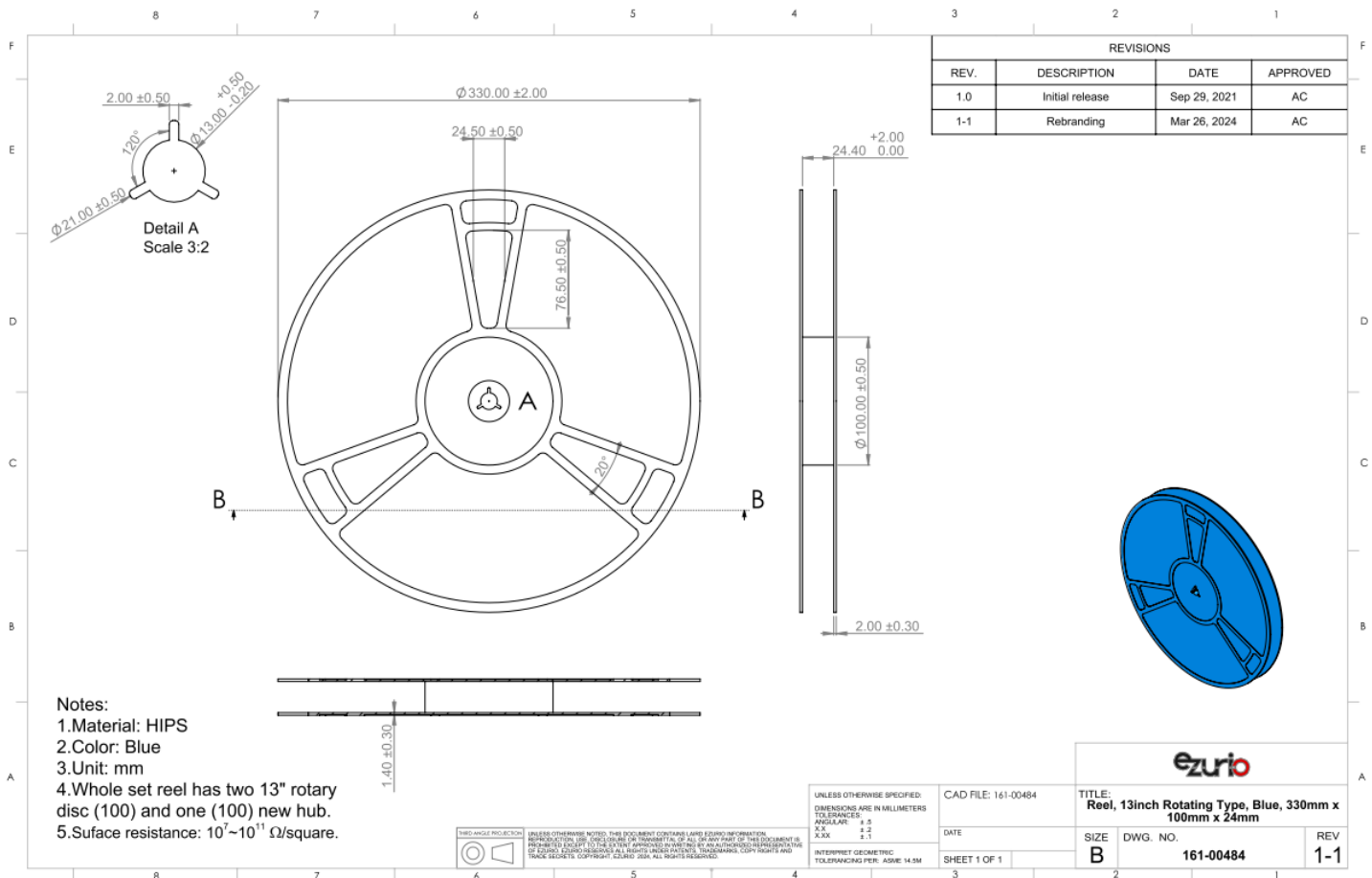
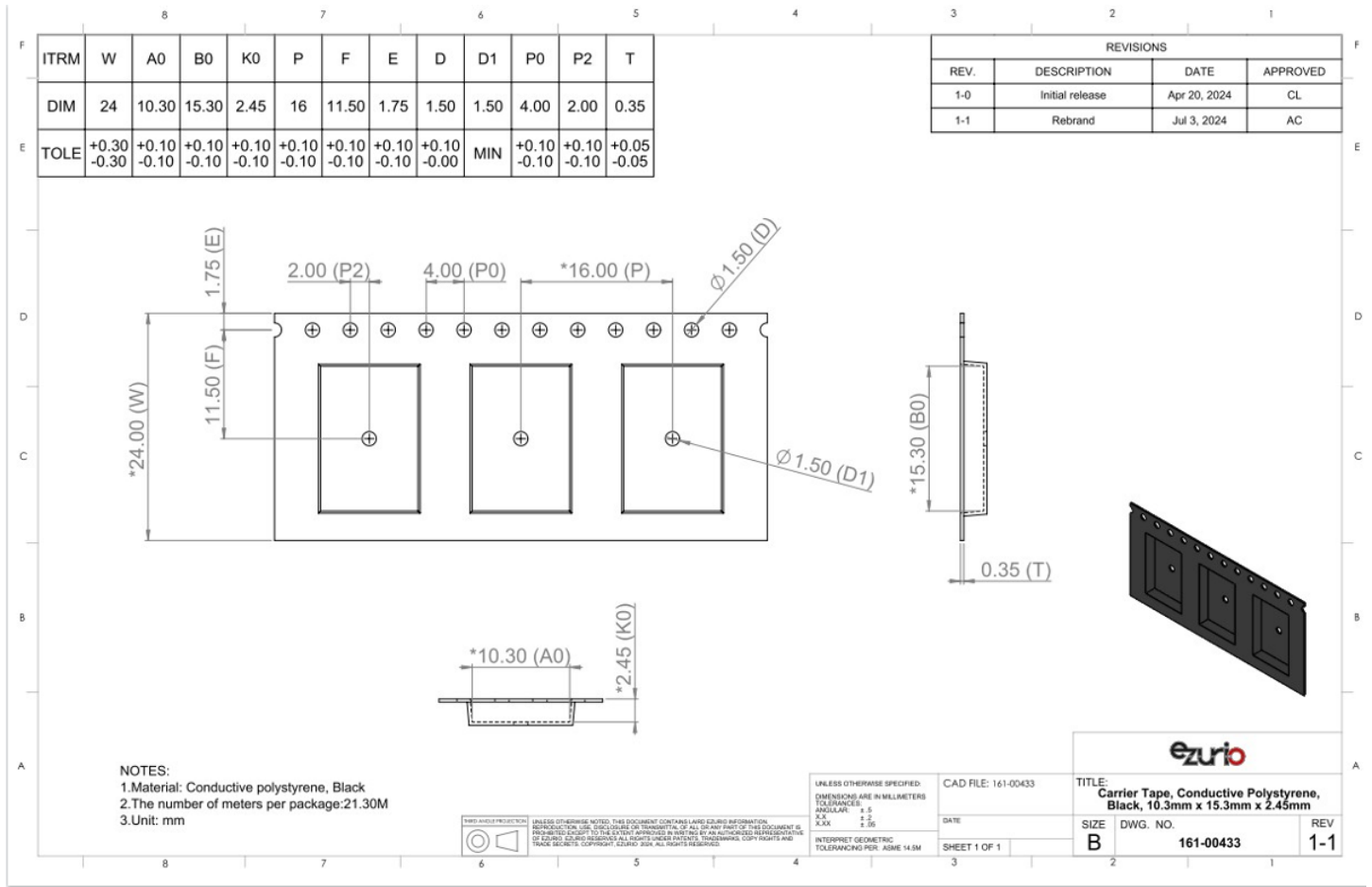

Figure 21: Reel specifications



**Figure 22: Tape specifications (Module Orientation - Antenna side of Module away from Tape Holes)**

There are 1,000 x BL5340 modules taped in a reel (and packaged in a pizza box) and five boxes per carton (5000 modules per carton). Reel, boxes, and carton are labeled with the appropriate labels. See [Carton Contents](#) for more information.

**9.2.2 Carton Contents and Packaging Process**

The following are the contents of the carton shipped for the BL5340 modules . The example used here is 453-00052R.

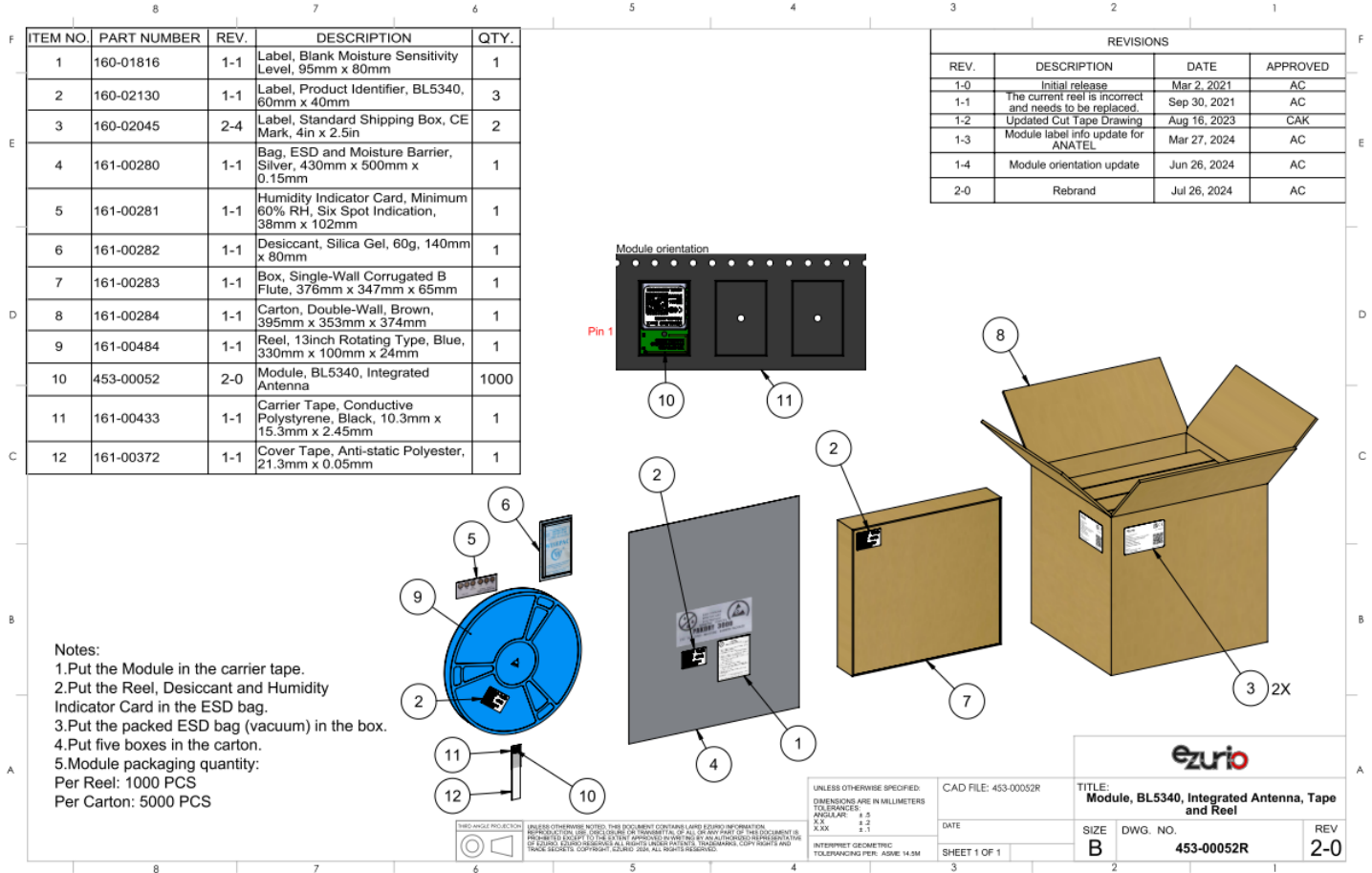

Figure 23: BL5340 carton contents

**9.2.3 Module Orientation in Cavity**

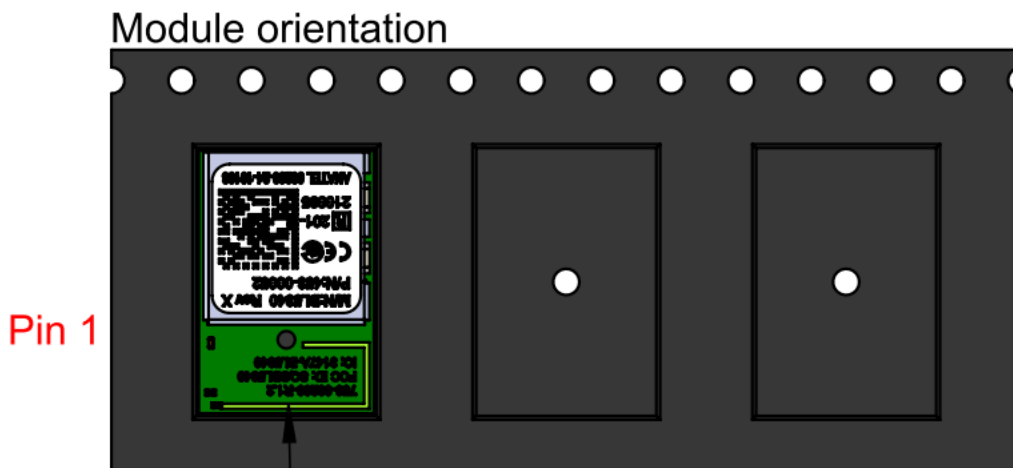

Figure 24: Module Orientation

### 9.2.4 Labeling

The following labels are located on the antistatic bag:

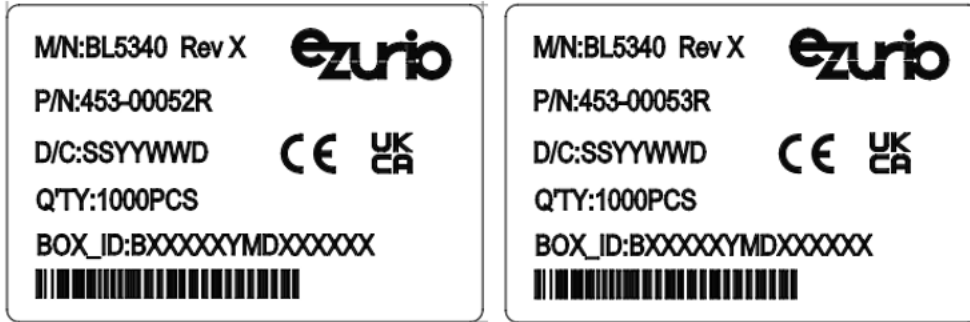

Figure 25: Antistatic bag labels

The following package label is located on the box:



Figure 25: Box package label

The following package label is located on both sides of the master carton:



Figure 26: Master carton package label

## 9.3 Reflow Parameters

The Moisture Sensitivity Level (MSL) for this module is MSL 4.

<https://www.ezurio.com/>

Prior to any reflow, it is important to ensure the modules were packaged to prevent moisture absorption. New packages contain desiccant (to absorb moisture) and a humidity indicator card to display the level maintained during storage and shipment. If directed to *bake units* on the card, see [Table 46](#) and follow instructions specified by IPC/JEDEC J-STD-033. A copy of this standard is available from the JEDEC website: <http://www.jedec.org/sites/default/files/docs/jstd033b01.pdf>

Any modules not manufactured before exceeding their floor life should be re-packaged with fresh desiccant and a new humidity indicator card. Floor life for MSL (Moisture Sensitivity Level) four devices is 72 hours in ambient environment  $\leq 30^{\circ}\text{C}/60\% \text{RH}$ .

**Table 46: Recommended baking times and temperatures**

MSL	125 °C		90 °C/≤ 5%RH		40 °C/ ≤ 5%RH	
	Baking Temp.		Baking Temp.		Baking Temp.	
	Saturated @ 30 °C/85%	Floor Life Limit + 72 hours @ 30 °C/60%	Saturated @ 30 °C/85%	Floor Life Limit + 72 hours @ 30 °C/60%	Saturated @ 30 °C/85%	Floor Life Limit + 72 hours @ 30 °C/60%
4	11 hours	7 hours	37 hours	23 hours	15 days	9 days

Ezurio surface mount modules are designed to be easily manufactured, including reflow soldering to a PCB. Ultimately it is the responsibility of the customer to choose the appropriate solder paste and to ensure oven temperatures during reflow meet the requirements of the solder paste. Ezurio surface mount modules conform to J-STD-020D1 standards for reflow temperatures.

**Important:** During reflow, modules should not be above 260° and not for more than 30 seconds. In addition, we recommend that the BL5340 module **does not** go through the reflow process more than one time; otherwise, the BL5340 internal component soldering may be impacted.

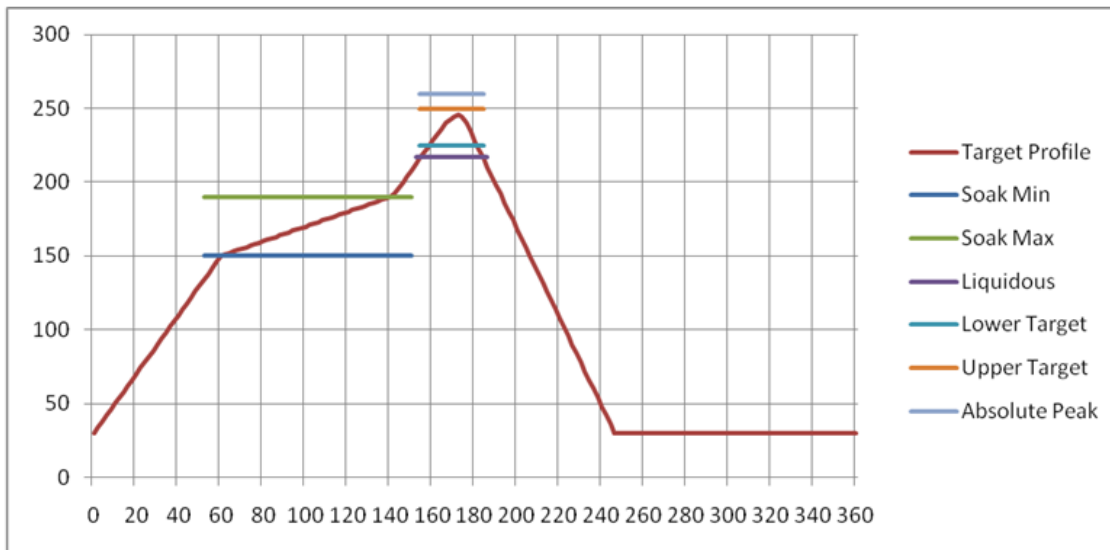

**Figure 27: Recommended reflow temperature**

Temperatures should not exceed the minimums or maximums presented in [Table 47](#).

**Table 47: Recommended maximum and minimum temperatures**

Specification	Value	Unit
Temperature Inc./Dec. Rate (max)	1~3	°C / Sec
Temperature Decrease rate (goal)	2-4	°C / Sec
Soak Temp Increase rate (goal)	.5 - 1	°C / Sec
Flux Soak Period (Min)	70	Sec
Flux Soak Period (Max)	120	Sec
Flux Soak Temp (Min)	150	°C
Flux Soak Temp (max)	190	°C

Specification	Value	Unit
Time Above Liquidous (max)	70	Sec
Time Above Liquidous (min)	50	Sec
Time In Target Reflow Range (goal)	30	Sec
Time At Absolute Peak (max)	5	Sec
Liquidous Temperature (SAC305)	218	°C
Lower Target Reflow Temperature	240	°C
Upper Target Reflow Temperature	250	°C
Absolute Peak Temperature	260	°C

## 10 Regulatory

**Note:** For complete regulatory information, refer to the BL5340 Regulatory Information document available from the [BL5340 product page](#).

The BL5340 holds current certifications in the following countries:

Country/Region	Regulatory ID
USA (FCC)	SQGBL5340
EU	N/A
Canada (ISED)	3147A-BL5340
Japan (MIC)	201-180112
Australia	N/A
New Zealand	N/A

## 11 Ordering Information

Part Number	Product Description
453-00052R	BL5340 series - Multi-Core / Protocol - Bluetooth® + 802.15.4 + NFC Module (Nordic nRF5340) – Integrated antenna (Tape/Reel)
453-00053R	BL5340 series - Multi-Core / Protocol - Bluetooth® + 802.15.4 + NFC Module (Nordic nRF5340) – Trace Pin (Tape/Reel)
453-00052C	BL5340 series - Multi-Core / Protocol - Bluetooth® + 802.15.4 + NFC Module (Nordic nRF5340) – Integrated antenna (Cut Tape)
453-00053C	BL5340 series - Multi-Core / Protocol - Bluetooth® + 802.15.4 + NFC Module (Nordic nRF5340) – Trace pin (Cut Tape)
453-00052-K1	Development kit for BL5340 Multi-Core / Protocol - Bluetooth® + 802.15.4 + NFC Module (Nordic nRF5340) – Integrated antenna
453-00053-K1	Development kit for BL5340 Multi-Core / Protocol - Bluetooth® + 802.15.4 + NFC Module (Nordic nRF5340) – Trace pin (Ext antenna)

## 12 Bluetooth SIG Qualification

### 12.1 Overview

The Bluetooth Qualification Process promotes global product interoperability and reinforces the strength of the Bluetooth® brand and ecosystem to the benefit of all Bluetooth SIG members. The Bluetooth Qualification Process helps member companies ensure their products that incorporate Bluetooth technology comply with the Bluetooth Patent & Copyright License Agreement and the Bluetooth Trademark License Agreement (collectively, the Bluetooth License Agreement) and Bluetooth Specifications.

The Bluetooth Qualification Process is defined by the [Qualification Program Reference Document \(QPRD\) v3](#).

To demonstrate that a product complies with the Bluetooth Specification(s), each member must for each of its products:

- Identify the product, the design included in the product, the Bluetooth Specifications that the design implements, and the features of each implemented specification
- Complete the Bluetooth Qualification Process by submitting the required documentation for the product under a user account belonging to your company

The Bluetooth Qualification Process consists of the phases shown below:

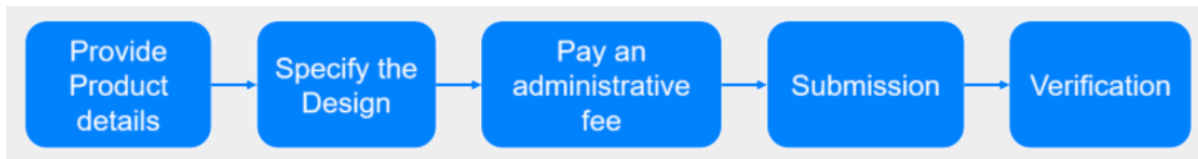

To complete the Qualification Process the company developing a Bluetooth End Product shall be a member of the Bluetooth SIG. To start the application please use the following link: [Apply for Adopter Membership](#)

### 12.2 Scope

This guide is intended to provide guidance on the Bluetooth Qualification Process for End Products that reference multiple existing designs, that have not been modified, (refer to Section 3.2.2.1 of the [Qualification Program Reference Document v3](#)).

For a Product that includes a new Design created by combining two or more unmodified designs that have DNs or QDIDs into one of the permitted combinations in Table 3.1 of the QPRDv3, a Member must also provide the following information:

- DNs or QDIDs for Designs included in the new Design
- The desired Core Configuration of the new Design (if applicable, see Table 3.1 below)
- The active TCRL Package version used for checking the applicable Core Configuration (including transport compatibility) and evaluating test requirements

Any included Design must not implement any Layers using withdrawn specification(s).

When creating a new Design using Option 2a, the Inter-Layer Dependency (ILD) between Layers included in the Design will be checked based on the latest TCRL Package version used among the included Designs.

For the purposes of this document, it is assumed that the member is combining unmodified Core-Controller Configuration and Core-Host Configuration designs, to complete a Core-Complete Configuration.

### 12.3 Qualification Steps When Referencing multiple existing designs, (unmodified) – Option 2a in the QPRDv3

For this qualification option, follow these steps:

1. To start a listing, go to: <https://qualification.bluetooth.com/>
2. Select **Start the Bluetooth Qualification Process**.
3. Product Details to be entered:
  - Project Name (this can be the product name or the Bluetooth Design name).
  - Product Description
  - Model Number

- Product Publication Date (the product publication date may not be later than 90 days after submission)
  - Product Website (optional)
  - Internal Visibility (this will define if the product will be visible to other users prior to publication)
    - If you have multiple End Products to list then you can select 'Import Multiple Products', firstly downloading and completing the template, then by 'Upload Product List'. This will populate Qualification Workspace with all your products.
4. Specify the Design:
- Do you include any existing Design(s) in your Product? Answer Yes, I do.
  - Enter the multiple DNs or QDIDs used in your, (for Option 2a two or more DNs or QDIDs must be referenced)
  - Select 'I'm finished entering DN's
  - Once the DNs or QDIDs are selected they will appear on the left-hand side, indicating the layers covered by the design (should show Core-Controller and Core Host Layers covered).
  - What do you want to do next? Answer, 'Combine unmodified Designs'.
  - The Qualification Workspace Tool will indicate that a new Design will be created and what type of Core-Complete configuration is selected.
  - An active TCRL will be selected for the design.
  - Perform the Consistency Check, which should result in no inconsistencies
  - If there are any inconsistencies these will need to be resolved before proceeding
  - Save and go to Test Plan and Documentation
5. Test Plan and Documentation
- a. As no modifications have been made to the combined designs the tool should report the following message:  
*'No test plan has been generated for your new Design. Test declarations and test reports do not need to be submitted. You can continue to the next step.'*
  - b. Save and go to Product Qualification fee
6. Product Qualification Fee:
- It's important to make sure a Prepaid Product Qualification fee is available as it is required at this stage to complete the Qualification Process.
  - Prepaid Product Qualification Fee's will appear in the available list so select one for the listing.
  - If one is not available select 'Pay Product Qualification Fee', payment can be done immediately via credit card, or you can pay via Invoice. Payment via credit will release the number immediately, if paying via invoice the number will not be released until the invoice is paid.
  - Once you have selected the Prepaid Qualification Fee, select 'Save and go to Submission'
7. Submission:
- Some automatic checks occur to ensure all submission requirements are complete.
  - To complete the listing any errors must be corrected
  - Once you have confirmed all design information is correct, tick all of the three check boxes and add your name to the signature page.
  - Now select 'Complete the Submission'.
  - You will be asked a final time to confirm you want to proceed with the submission, select 'Complete the Submission'.
  - Qualification Workspace will confirm the submission has been submitted. The Bluetooth SIG will email confirmation once the submission has been accepted, (normally this takes 1 working day).
8. Download Product and Design Details (SDoC):
- a. You can now download a copy of the confirmed listing from the design listing page and save a copy in your Compliance Folder

For further information, please refer to the following webpage:

<https://www.bluetooth.com/develop-with-bluetooth/qualification-listing/>

## 12.4 Example Design Combinations

The following gives an example of a design possible under option 2a:

**Ezurio Controller Subsystem + Nordic nRF Connect SDK Host Subsystem (Ezurio BL5340 based design)**

Design Name	Owner	Design Number (DN)	Link to listing on the SIG website
Ezurio BL5340/BL5340PA (Core Controller)	Ezurio	Q361551	<a href="https://qualification.bluetooth.com/ListingDetails/295206">https://qualification.bluetooth.com/ListingDetails/295206</a>
nRF Connect SDK Host component (Core Host)	Nordic Semiconductor ASA	Q358851	<a href="https://qualification.bluetooth.com/ListingDetails/291114">https://qualification.bluetooth.com/ListingDetails/291114</a>

## 12.5 Qualify More Products

If you develop further products based on the same design in the future, it is possible to add them free of charge. The new product must not modify the existing design i.e add ICS functionality, otherwise a new design listing will be required.

To add more products to your design, select 'Manage Submitted Products' in the [Getting Started](#) page, Actions, Qualify More Products. The tool will take you through the updating process.

## 13 Reliability Tests

The BL5340 module went through the below reliability tests and passed.

Test Sequence	Test Item	Test Limits and Pass	Test Conditions	
1	Vibration Test	JESD22-B103B Vibration, Variable frequency	Sample	Unpowered
			Sample Number	3
			Vibration Waveform	Sine waveform
			Vibration Frequency/Displacement	20 to 80 Hz/20 g
			Vibration Frequency/Acceleration	80 to 2000 Hz/20 g
			Cycle Time	4 minutes
			Number of Cycles	4 cycles per axis
			Vibration Axis	X, Y, and Z (rotating each axis on vertical vibration table)
2	Mechanical Shock	JESD22-B104C	Sample	Unpowered
			Sample Number	3
			Pulse Shape	Half-sine waveform
			Impact Acceleration	1500 g
			Pulse Duration	0.5 ms
			Number of Shocks	30 shocks (5 shocks for each face)
			Orientation	Bottom, top, left, right, front, and rear faces
3	Thermal Shock	JESD22-A104E Temperature cycling	Sample	Unpowered
			Sample Number	3
			Temperature Transition Time	Less than 30 seconds
			Temperature Cycle	-40°C (10 minutes), +105°C (10 minutes)
			Number of Cycles	350

Before and after the testing, visual inspection showed no physical defect on samples.

After Vibration test and Mechanical Shock testing, the samples were functionally tested, and all samples functioned as normal. Then after Thermal shock test, the samples were functionally tested, and all samples functioned as normal.

## 14 Additional Information

Please contact your local sales representative or our support team for further assistance:

<b>Headquarters</b>	Ezurio 50 S. Main St. Suite 1100 Akron, OH 44308 USA
<b>Website</b>	<a href="http://www.ezurio.com">http://www.ezurio.com</a>
<b>Technical Support</b>	<a href="http://www.ezurio.com/resources/support">http://www.ezurio.com/resources/support</a>
<b>Sales Contact</b>	<a href="http://www.ezurio.com/contact">http://www.ezurio.com/contact</a>

**Note:** Information contained in this document is subject to change.

Ezurio's products are subject to standard [Terms & Conditions](#).

<http://www.ezurio.com>

© Copyright 2025 Ezurio. All Rights Reserved. Any information furnished by Ezurio and its agents is believed to be accurate but cannot be guaranteed. All specifications are subject to change without notice. Responsibility for the use and application of Ezurio materials or products rests with the end user since Ezurio and its agents cannot be aware of all potential uses. Ezurio makes no warranties as to non-infringement nor as to the fitness, merchantability, or sustainability of any Ezurio materials or products for any specific or general uses. Ezurio or any of its affiliates or agents shall not be liable for incidental or consequential damages of any kind. All Ezurio products are sold pursuant to the Ezurio Terms and Conditions of Sale in effect from time to time, a copy of which will be furnished upon request. Nothing herein provides a license under any Ezurio or any third-party intellectual property right. Ezurio and its associated logos are trademarks owned by Ezurio and/or its affiliates.