

1

2

3

4

A

B

C

D

A

B

C

D

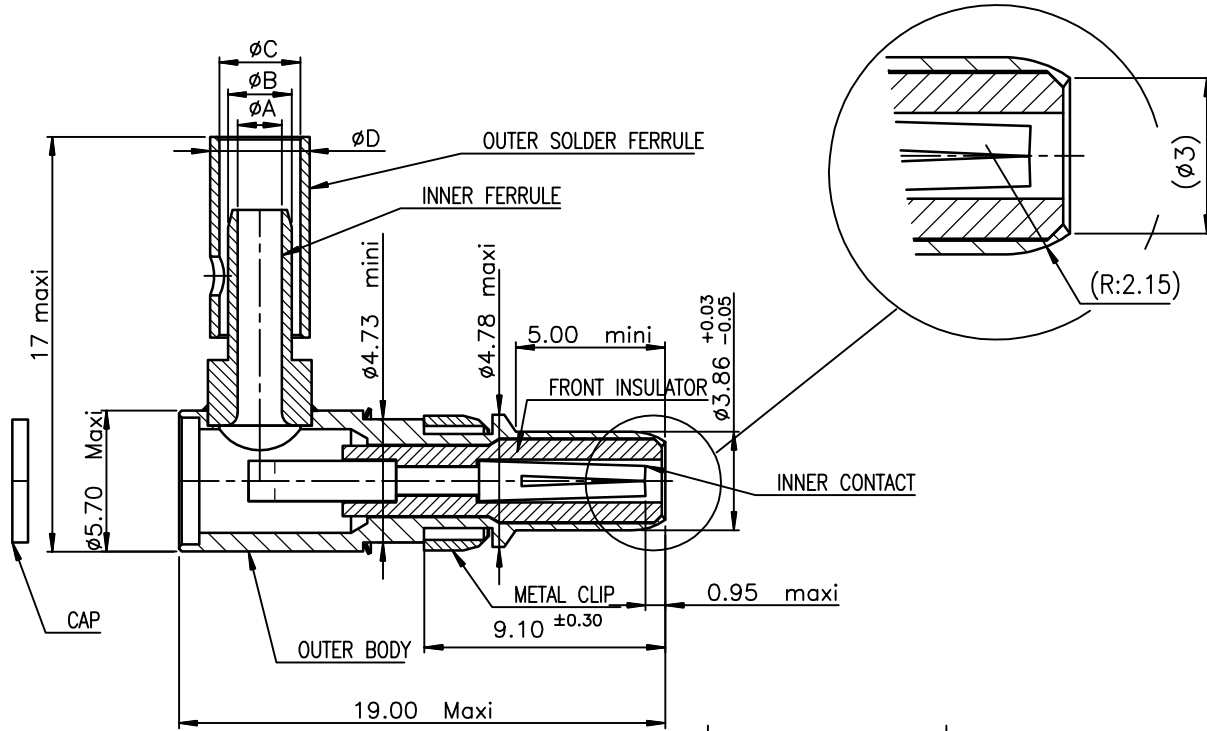

ELECTRICAL CHARACTERISTICS

- Impedance: 50 Ohm
- Working frequency: 1GHz max
- Dielectric with standing voltage: 600V
- Insulation resistance 5000: 14 Ohm
- Contact resistance < 5 mOhm
- Insertion loss: < 0.2 dB

MECHANICAL CHARACTERISTICS

- Mating force per set of contact 0.4 N to 9 N
- Mating endurance 500
- Temperature -55° to +125 °C

TOOLING

- Coaxial contact extraction tool 8630-07A

DM537415000NCLF	RIGHT ANGLE MALE COAXIAL CONTACT	1.00	1.75	2.32	3.20	RG 178 B/U RG 196 A/U KX 21 A
PART NUMBER	DESIGNATION	$\phi A^{+0.10}_0$	$\phi B^{\pm 0.05}$	$\phi C^{+0.10}_0$	$\phi D^{\pm 0.10}$	CABLE REF.



Copyright FCI.

NOTE:RoHS INFORMATIONS

- The "LF" product meets European union Directives and other country regulations as described in GS-22-008.
- The product is not intended to be exposed to a manufacturing solder process.
- Packaging spec: see GS-14-920.

rev	ecn no	dr	date
A	LS05-0086	MPE	2005/10/12
B	LS05-0107	MPE	2005/12/20
C	LS07-0001	MPE	2007/01/09
D	LS07-0114	MPE	2007/04/24
E	F10-0086	LSA	2010/08/20
-	-	-	-
-	-	-	-

www.fciconnect.com		surface ISO 1302 ✓	tolerance std ISO 406 ISO 1101	projection 	mm ↔
TOLERANCES UNLESS OTHERWISE SPECIFIED					
Dr	PESSON	2005/10/12	ANGULAR	0.X	±0.1
Eng	PESSON	2005/10/12	LINEAR	0.XX	±0.1
Chr	LEGARE	2005/10/12	0.XX ±2	0.XXX	±0.1
Appr	LEGARE	2005/10/12	Product family	D-SUB	Spec ref -
FCI title RIGHT ANGLE MALE COAXIAL CONTACT SOLDER TO CABLE			dwg no C01-8639-2148		Rev. E
catalog no			CUSTOMER sheet 1 of 1		

REV F - 2006-04-17

1

2

3

4

PDM: Rev:E

STATUS:Released

Printed: Oct 01, 2010