

PFV / PZF シリーズ  
SERIES

125°C 4,000時間品  
125°C 4,000 hours

AEC-Q200

RoHS  
Compliance



◆規格表 / SPECIFICATIONS

項目 Items	特性 Characteristics													
カテゴリ温度範囲 Category Temperature Range	-55 ~ +125°C													
定格電圧範囲 Rated Voltage Range	25 ~ 80Vdc													
静電容量許容差 Capacitance Tolerance	±20% (20°C, 120Hz)													
漏れ電流 Leakage Current (MAX)	I=0.01CV又は3μAのいずれか大なる値以下 (定格電圧印加2分後) I=0.01CV or 3μA whichever is greater. (After 2 minute) I=漏れ電流(μA) C=静電容量(μF) V=定格電圧(Vdc) I = Leakage Current C = Capacitance V = Rated Voltage													
損失角の正接 (tan δ) Dissipation Factor (MAX)	<table border="1"> <tr> <td>定格電圧(Vdc) Rated Voltage</td> <td>25</td> <td>35</td> <td>50</td> <td>63</td> <td>80</td> <td rowspan="2">(20°C, 120Hz)</td> </tr> <tr> <td>tan δ</td> <td>0.14</td> <td>0.12</td> <td>0.10</td> <td>0.09</td> <td>0.08</td> </tr> </table>	定格電圧(Vdc) Rated Voltage	25	35	50	63	80	(20°C, 120Hz)	tan δ	0.14	0.12	0.10	0.09	0.08
定格電圧(Vdc) Rated Voltage	25	35	50	63	80	(20°C, 120Hz)								
tan δ	0.14	0.12	0.10	0.09	0.08									
耐久 Endurance	125°C中で4000時間定格電圧(定格リプル重畳)印加後、下記の規格を満足すること。 After applying rated voltage with rated ripple current for 4000 hours at 125°C, the capacitors shall meet the following Criteria.													
高温高湿負荷 Biased Humidity	85°C、85% RH中で2000時間定格電圧印加後、下記の規格を満足すること。 After applying rated voltage for 2000 hours at 85°C and humidity of 85%, the capacitors shall meet the following Criteria.													
規格 Criteria	<table border="1"> <tr> <td>静電容量変化率 Capacitance Change</td> <td>初期値の ±30%以内 Within ±30% of the initial value.</td> </tr> <tr> <td>損失角の正接 Dissipation Factor</td> <td>規定値の 200%以下 Not more than 200% of the specified value.</td> </tr> <tr> <td>等価直列抵抗 ESR</td> <td>規格値の 200% 以下 Not more than 200% of the specified value.</td> </tr> <tr> <td>漏れ電流 Leakage Current</td> <td>規格値以下 Not more than the specified value.</td> </tr> </table>	静電容量変化率 Capacitance Change	初期値の ±30%以内 Within ±30% of the initial value.	損失角の正接 Dissipation Factor	規定値の 200%以下 Not more than 200% of the specified value.	等価直列抵抗 ESR	規格値の 200% 以下 Not more than 200% of the specified value.	漏れ電流 Leakage Current	規格値以下 Not more than the specified value.					
静電容量変化率 Capacitance Change	初期値の ±30%以内 Within ±30% of the initial value.													
損失角の正接 Dissipation Factor	規定値の 200%以下 Not more than 200% of the specified value.													
等価直列抵抗 ESR	規格値の 200% 以下 Not more than 200% of the specified value.													
漏れ電流 Leakage Current	規格値以下 Not more than the specified value.													
低温特性 Low Temperature Stability (インピーダンス比) Impedance Ratio (MAX)	$Z(-25°C) / Z(+20°C) \leq 1.5$ (100kHz) $Z(-55°C) / Z(+20°C) \leq 2.0$													

◆呼称方法 / PART NUMBER

□□□	PFV/ PZF	□□□□□	M	□□□	□□	φD×L
定格電圧 Rated Voltage	シリーズ名 Series	静電容量 Capacitance	静電容量許容差 Capacitance Tolerance	副記号 Option	リード加工記号 Lead Forming	ケースサイズ Case Size

◆リップル電流補正係数 /  
MULTIPLIER FOR RIPPLE CURRENT

周波数 (Hz) Frequency	f	100 ≤ f < 1k	1k ≤ f < 10k	10k ≤ f < 20k
係数 Coefficient		0.05	0.30	0.70
周波数 (Hz) Frequency	f	20k ≤ f < 50k	50k ≤ f < 100k	100k ≤ f
係数 Coefficient		0.80	0.90	1.00

◆表示 / MARKING

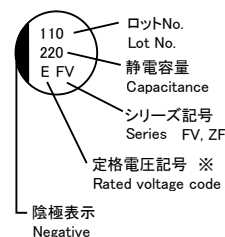

※電圧記号 Voltage Code

定格電圧 Rated Voltage (Vdc)	25	35	50	63	80
電圧記号 Voltage Code	E	V	H	J	K



# 導電性高分子ハイブリッドアルミ電解コンデンサ CONDUCTIVE POLYMER HYBRID ALUMINUM ELECTROLYTIC CAPACITORS

PFV/PZF

## ◆寸法図/DIMENSIONS

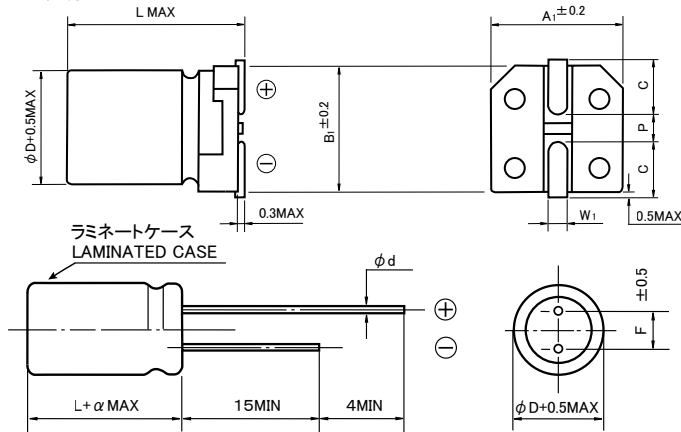

(mm)						
φD	L	A1	B1	C	W1	P
6.3	6.1	6.6	6.6	2.7	0.5~0.8	1.8
6.3	8	6.6	6.6	2.7	0.5~0.8	1.8
8	10.5	8.3	8.3	2.9	0.8~1.1	3.1
10	10.5	10.3	10.3	3.2	0.8~1.1	4.5

(mm)				
φD	L	F	φd	α
8	9	3.5	0.6	1.5
10	9	5.0	0.6	1.5

## ◆標準品一覧表/STANDARD SIZE

定格電圧 Rated Voltage (Vdc)	静電容量 Capacitance (μF)	外形寸法 Size φD X L (mm)		等価直列抵抗 ESR (mΩ MAX, 100kHz)		定格リップル電流 Rated Ripple Current (mA rms / 125°C, 100kHz)	許容リップル電流 Permissible Ripple Current (mA rms)	
		PFV series (SMD)	PZF series (Radial Lead type)	20°C	-40°C		125°C, 100kHz	100°C, 100kHz
25	56	6.3×6.1	—	50	—	1170	1490	2110
	100	6.3×8	—	30	—	1810	2320	3290
	220	8×10.5	8×9	27	—	2070	2650	3760
	330	10×10.5	10×9	20	—	2590	3320	4700
35	47	6.3×6.1	—	60	—	1170	1490	2110
	68	6.3×8	—	35	—	1810	2320	3290
	150	8×10.5	8×9	27	—	2070	2650	3760
	270	10×10.5	10×9	20	—	2590	3320	4700
50	22	6.3×6.1	—	80	—	970	1240	1760
	33	6.3×8	—	40	—	1430	1820	2580
	68	8×10.5	8×9	30	—	1620	2070	2930
	100	10×10.5	10×9	28	—	2070	2650	3760
63	10	6.3×6.1	—	120	—	910	1160	1640
	22	6.3×8	—	80	—	1170	1490	2110
	33	8×10.5	8×9	40	—	1430	1820	2580
	56	10×10.5	10×9	30	—	1810	2320	3290
80	22	8×10.5	8×9	45	—	1430	1820	2580
	27	8×10.5	8×9	45	—	1430	1820	2580
	39	10×10.5	10×9	35	—	1550	1990	2820
	47	10×10.5	10×9	35	—	1700	2180	3090

## ◆温度係数/TEMPERATURE COEFFICIENT FOR RIPPLE CURRENT

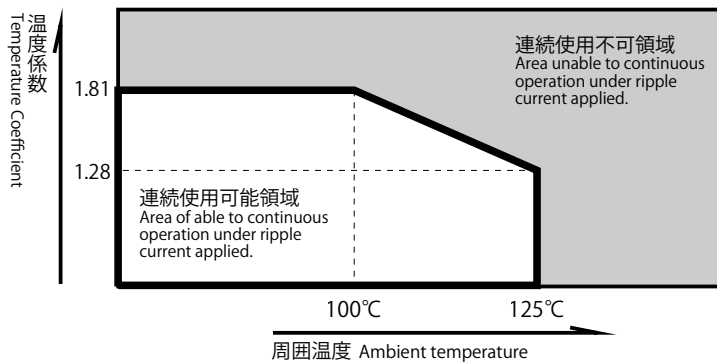

温度 Temperature T (°C)	T ≤ 100	105	110	115	125
係数 Coefficient (I <sub>MAX</sub> /I <sub>0</sub> )	1.81	1.72	1.62	1.52	1.28

温度係数 I<sub>MAX</sub>/I<sub>0</sub>: 定格リップル電流 (I<sub>0</sub>) を超えて連続印加可能なリップル電流最大値 (I<sub>MAX</sub>) を示す係数。寿命推定時間は寿命計算式に従う。

Temperature Coefficient I<sub>MAX</sub>/I<sub>0</sub>: Coefficient indicating the maximum permissible ripple current (I<sub>MAX</sub>) that can be continuously applied beyond the rated current (I<sub>0</sub>). Estimated lifetime complies with our lifetime calculation formula.