

ON Semiconductor

Is Now

onsemi™

To learn more about onsemi™, please visit our website at
www.onsemi.com

onsemi and **onsemi** and other names, marks, and brands are registered and/or common law trademarks of Semiconductor Components Industries, LLC dba "**onsemi**" or its affiliates and/or subsidiaries in the United States and/or other countries. **onsemi** owns the rights to a number of patents, trademarks, copyrights, trade secrets, and other intellectual property. A listing of **onsemi** product/patent coverage may be accessed at www.onsemi.com/site/pdf/Patent-Marking.pdf. **onsemi** reserves the right to make changes at any time to any products or information herein, without notice. The information herein is provided "as-is" and **onsemi** makes no warranty, representation or guarantee regarding the accuracy of the information, product features, availability, functionality, or suitability of its products for any particular purpose, nor does **onsemi** assume any liability arising out of the application or use of any product or circuit, and specifically disclaims any and all liability, including without limitation special, consequential or incidental damages. Buyer is responsible for its products and applications using **onsemi** products, including compliance with all laws, regulations and safety requirements or standards, regardless of any support or applications information provided by **onsemi**. "Typical" parameters which may be provided in **onsemi** data sheets and/or specifications can and do vary in different applications and actual performance may vary over time. All operating parameters, including "Typicals" must be validated for each customer application by customer's technical experts. **onsemi** does not convey any license under any of its intellectual property rights nor the rights of others. **onsemi** products are not designed, intended, or authorized for use as a critical component in life support systems or any FDA Class 3 medical devices or medical devices with a same or similar classification in a foreign jurisdiction or any devices intended for implantation in the human body. Should Buyer purchase or use **onsemi** products for any such unintended or unauthorized application, Buyer shall indemnify and hold **onsemi** and its officers, employees, subsidiaries, affiliates, and distributors harmless against all claims, costs, damages, and expenses, and reasonable attorney fees arising out of, directly or indirectly, any claim of personal injury or death associated with such unintended or unauthorized use, even if such claim alleges that **onsemi** was negligent regarding the design or manufacture of the part. **onsemi** is an Equal Opportunity/Affirmative Action Employer. This literature is subject to all applicable copyright laws and is not for resale in any manner. Other names and brands may be claimed as the property of others.



ON Semiconductor®

FSUSB104 — Low-Power, Two-Port, Hi-Speed, USB2.0 (480 Mbps) Switch

Features

- Low On Capacitance: 3.7 pF Typical
- Low On Resistance: 3.9 Ω Typical
- Low Power Consumption: 1 μA Maximum
 - 15 μA Maximum I_{CC}T over an Expanded Voltage Range (V_{IN}=1.8 V, V_{CC}=4.3 V)
- Wide -3 db Bandwidth: > 720 MHz
- Packaged in Pb-free 10-Lead UMLP (1.4 x 1.8 mm)
- 8 kV ESD Rating, >16 kV Power/GND ESD Rating
- Power-Off Protection on All Ports When V_{CC}=0 V
 - D+/D- Pins Tolerate up to 5.25 V

Applications

- Cell phone, PDA, Digital Camera, and Notebook
- LCD Monitor, TV, and Set-Top Box

Description

The FSUSB104 is a bi-directional, low-power, two-port, Hi-Speed, USB2.0 switch. Configured as a double-pole, double-throw switch (DPDT) switch, it is optimized for switching between two Hi-Speed (480 Mbps) sources or a Hi-Speed and Full-Speed (12 Mbps) source.

The FSUSB104 is compatible with the requirements of USB2.0 and features an extremely low on capacitance (C_{ON}) of 3.7 pF. The wide bandwidth of this device (720 MHz) exceeds the bandwidth needed to pass the third harmonic, resulting in signals with minimum edge and phase distortion. Superior channel-to-channel crosstalk also minimizes interference.

The FSUSB104 contains special circuitry on the switch I/O pins for applications where the V_{CC} supply is powered-off (V_{CC}=0), which allows the device to withstand an over-voltage condition. This device is designed to minimize current consumption even when the control voltage applied to the SEL pin is lower than the supply voltage (V_{CC}). This feature is especially valuable to ultra-portable applications, such as cell phones, allowing for direct interface with the general-purpose I/Os of the baseband processor. Other applications include switching and connector sharing in portable cell phones, PDAs, digital cameras, printers, and notebook computers.

Ordering Information

Part Number	Top Mark	Operating Temperature Range	Package
FSUSB104UMX	JF	-40 to +85°C	10-Lead, Quad, Ultrathin Molded Leadless Package (UMLP), 1.4 x 1.8 mm

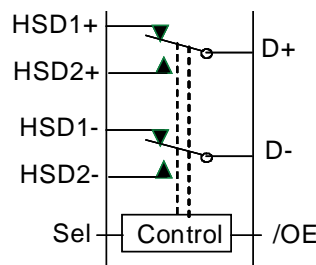

Figure 1. Analog Symbol

Pin Assignments

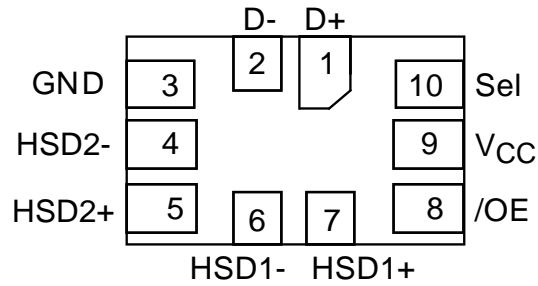

Figure 2. Pin Assignment (Top Through View)

Pin Definitions

Pin #	Name	Description
1	D+	USB Data Bus
2	D-	USB Data Bus
3	GND	Ground
4	HSD2-	Multiplexed Source Inputs
5	HSD2+	Multiplexed Source Inputs
6	HSD1-	Multiplexed Source Inputs
7	HSD1+	Multiplexed Source Inputs
8	/OE	Switch Enable
9	V _{CC}	Supply Voltage
10	Sel	Switch Select

Truth Table

Sel	/OE	Function
X	HIGH	Disconnect
LOW	LOW	D+, D- = HSD1+, HSD1-
HIGH	LOW	D+, D- = HSD2+, HSD2-

Absolute Maximum Ratings

Stresses exceeding the absolute maximum ratings may damage the device. The device may not function or be operable above the recommended operating conditions and stressing the parts to these levels is not recommended. In addition, extended exposure to stresses above the recommended operating conditions may affect device reliability. The absolute maximum ratings are stress ratings only.

Symbol	Parameter	Min.	Max.	Unit	
V _{CC}	Supply Voltage	-0.5	5.6	V	
V _{CNTRL}	DC Input Voltage (S, /OE) ⁽¹⁾	-0.5	V _{CC}	V	
V _{SW}	DC Switch I/O Voltage ⁽¹⁾	-0.5	5.25	V	
I _{IK}	DC Input Diode Current	-50		mA	
I _{OUT}	DC Output Current		50	mA	
T _{STG}	Storage Temperature	-65	+150	°C	
ESD	Human Body Model, JEDEC: JESD22-A114	All Pins		7	kV
		I/O to GND		8	
		Power to GND		16	
	Charged Device Model, JEDEC: JESD22-C101			2	

Note:

- The input and output negative ratings may be exceeded if the input and output diode current ratings are observed.

Recommended Operating Conditions

The Recommended Operating Conditions table defines the conditions for actual device operation. Recommended operating conditions are specified to ensure optimal performance to the datasheet specifications. ON Semiconductor does not recommend exceeding them or designing to Absolute Maximum Ratings.

Symbol	Parameter	Min.	Max.	Unit
V _{CC}	Supply Voltage	3.0	4.4	V
V _{CNTRL}	Control Input Voltage (S, /OE) ⁽²⁾	0	V _{CC}	V
V _{SW}	Switch I/O Voltage	-0.5	4.5	V
T _A	Operating Temperature	-40	+85	°C

Note:

- The control input must be held HIGH or LOW and it must not float.

DC Electrical Characteristics

All typical values are at 25°C unless otherwise specified.

Symbol	Parameter	Conditions	V _{CC} (V)	T _A =- 40°C to +85°C			Units
				Min.	Typ.	Max.	
V _{IK}	Clamp Diode Voltage	I _{IN} =-18 mA	3.0			-1.2	V
V _{IH}	Input Voltage High		3.0 to 3.6	1.3			V
			4.3	1.7			V
V _{IL}	Input Voltage Low		3.0 to 3.6			0.5	V
			4.3			0.7	V
I _{IN}	Control Input Leakage	V _{SW} =0 to V _{CC}	4.3	-1		1	μA
I _{OZ}	Off State Leakage	0 ≤ D _n , HSD1 _n , HSD2 _n ≤ 3.6V	4.3	-2		2	μA
I _{OFF}	Power-Off Leakage Current (All I/O Ports)	V _{SW} =0 V to 4.3 V, V _{CC} =0 V Figure 4	0	-2		2	μA
R _{ON}	HS Switch On Resistance ⁽³⁾	V _{SW} =0.4 V, I _{ON} =-8 mA Figure 3,	3.0		3.9	6.5	Ω
ΔR _{ON}	HS Delta Ron ⁽⁴⁾	V _{SW} =0.4 V, I _{ON} =-8 mA	3.0		0.65		Ω
I _{CC}	Quiescent Supply Current	V _{CNTRL} =0 or V _{CC} , I _{OUT} =0	4.3			1.0	μA
I _{CC} T	Increase in I _{CC} Current per Control Voltage and V _{CC}	V _{CNTRL} =2.6 V, V _{CC} =4.3 V	4.3			10.0	μA
		V _{CNTRL} =1.8 V, V _{CC} =4.3 V	4.3			15.0	μA

Notes:

3. Measured by the voltage drop between HSD_n and D_n pins at the indicated current through the switch. On resistance is determined by the lower of the voltage on the two (HSD_n or D_n ports).
4. Guaranteed by characterization. Not tested in production.

AC Electrical Characteristics

All typical value are for $V_{CC}=3.3\text{ V}$ at 25°C unless otherw ise specified.

Symbol	Parameter	Conditions	V_{CC} (V)	$T_A=-40^{\circ}\text{C}$ to $+85^{\circ}\text{C}$			Units
				Min.	Typ.	Max.	
t_{ON}	Turn-On Time S, /OE to Output	$R_L=50\ \Omega$, $C_L=5\ \text{pF}$ $V_{SW}=0.8\ \text{V}$ Figure 5, Figure 6	3.0 to 3.6		13	30	ns
t_{OFF}	Turn-Off Time S, /OE to Output	$R_L=50\ \Omega$, $C_L=5\ \text{pF}$ $V_{SW}=0.8\ \text{V}$ Figure 5, Figure 6	3.0 to 3.6		12	25	ns
t_{PD}	Propagation Delay ⁽⁵⁾	$C_L=5\ \text{pF}$, $R_L=50\ \Omega$ Figure 5, Figure 7	3.3		0.25		ns
t_{BBM}	Break-Before-Make	$R_L=50\ \Omega$, $C_L=5\ \text{pF}$ $V_{SW1}=V_{SW2}=0.8\ \text{V}$ Figure 9	3.0 to 3.6	2.0		6.5	ns
O_{IRR}	Off Isolation	$R_L=50\ \Omega$, $f=240\ \text{MHz}$ Figure 11	3.0 to 3.6		-30		dB
Xtalk	Non-Adjacent Channel Crosstalk	$R_L=50\ \Omega$, $f=240\ \text{MHz}$ Figure 12	3.0 to 3.6		-45		dB
BW	-3db Bandwidth	$R_L=50\ \Omega$, $C_L=0\ \text{pF}$ Figure 10	3.0 to 3.6		720		MHz
		$R_L=50\ \Omega$, $C_L=5\ \text{pF}$ Figure 10			550		MHz

Note:

5. Guaranteed by characterization. Not tested in production.

USB Hi-Speed-Related AC Electrical Characteristics

Symbol	Parameter	Conditions	V_{CC} (V)	$T_A=-40^{\circ}\text{C}$ to $+85^{\circ}\text{C}$			Units
				Min.	Typ.	Max.	
$t_{SK(P)}$	Skew of Opposite Transitions of the Same Output ⁽⁶⁾	$C_L=5\ \text{pF}$, $R_L=50\ \Omega$ Figure 8	3.0 to 3.6		20		ps
t_J	Total Jitter ⁽⁶⁾	$R_L=50\ \Omega$, $C_L=5\ \text{pF}$, $t_R=t_F=500\text{ps}$ (10-90%) at 480 Mbps (PRBS= $2^{15}-1$)	3.0 to 3.6		200		ps

Note:

6. Guaranteed by characterization. Not tested in production.

Capacitance

Symbol	Parameter	Conditions	$T_A=-40^{\circ}\text{C}$ to $+85^{\circ}\text{C}$			Units
			Min.	Typ.	Max.	
C_{IN}	Control Pin Input Capacitance	$V_{CC}=0\ \text{V}$		1.5		pF
C_{ON}	D+/D- On Capacitance	$V_{CC}=3.3\ \text{V}$, /OE=0 V, $f=240\ \text{MHz}$ Figure 14		3.7		
C_{OFF}	D1n, D2n Off Capacitance	V_{CC} and /OE=3.3 V See Figure 13		2.0		

Test Diagrams

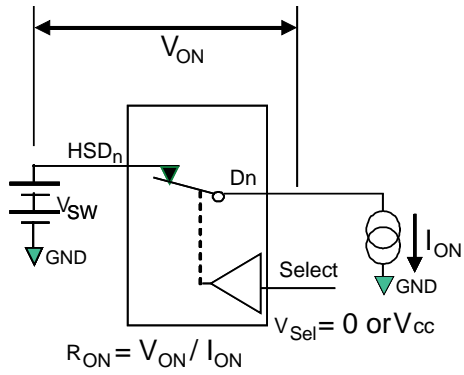
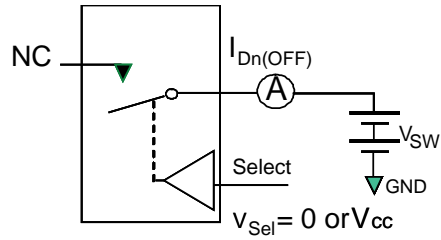
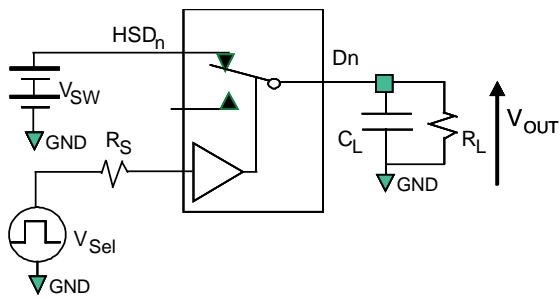

Figure 3. On Resistance



**Each switch port is tested separately

Figure 4. Off Leakage



R_L , R_S , and C_L are functions of the application environment (see AC Tables for specific values)
 C_L includes test fixture and stray capacitance.

Figure 5. AC Test Circuit Load

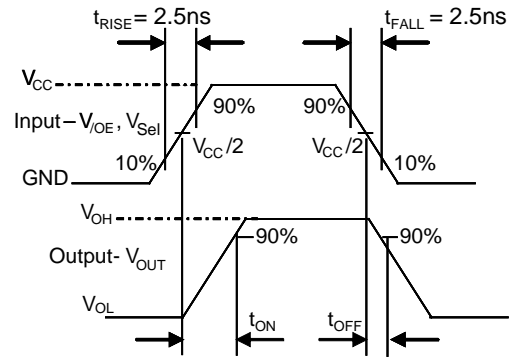

Figure 6. Turn-On / Turn-Off Waveforms

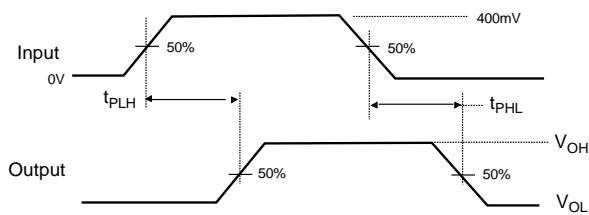

Figure 7. Propagation Delay ($t_{RtF} = 500 \text{ ps}$)

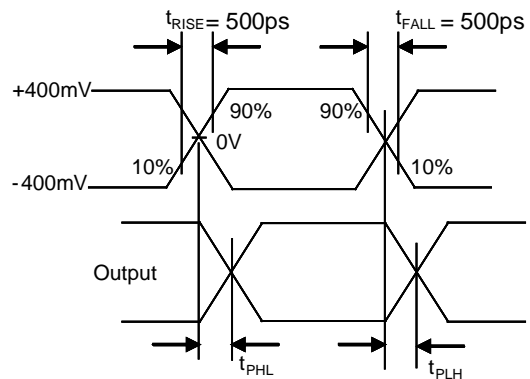

Figure 8. Intra-Pair Skew Test $t_{SK(P)}$

Test Diagrams (Continued)

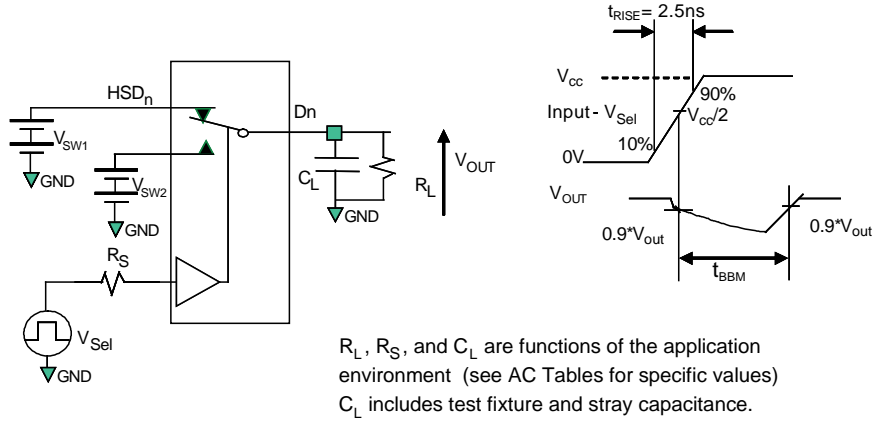

Figure 9. Break-Before-Make Interval Timing

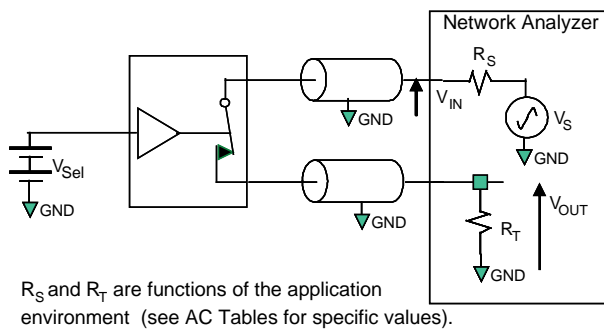

Figure 10. Bandwidth

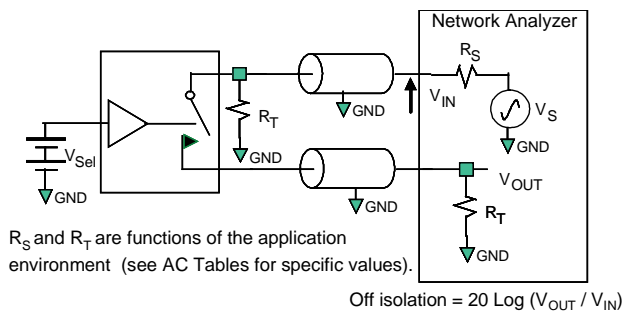

Figure 11. Channel Off Isolation

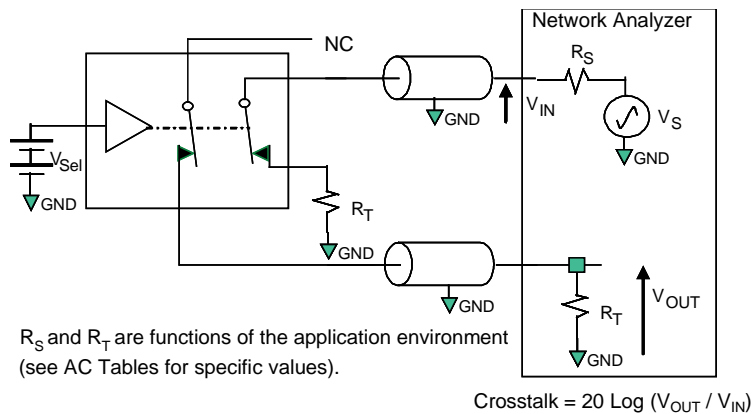

Figure 12. Non-Adjacent Channel-to-Channel Crosstalk

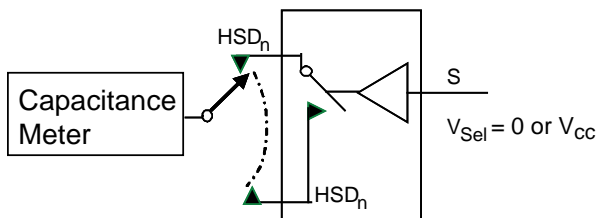

Figure 13. Channel Off Capacitance

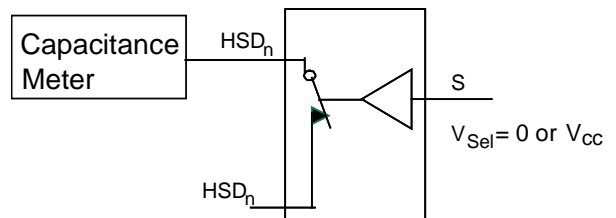

Figure 14. Channel On Capacitance

Physical Dimensions

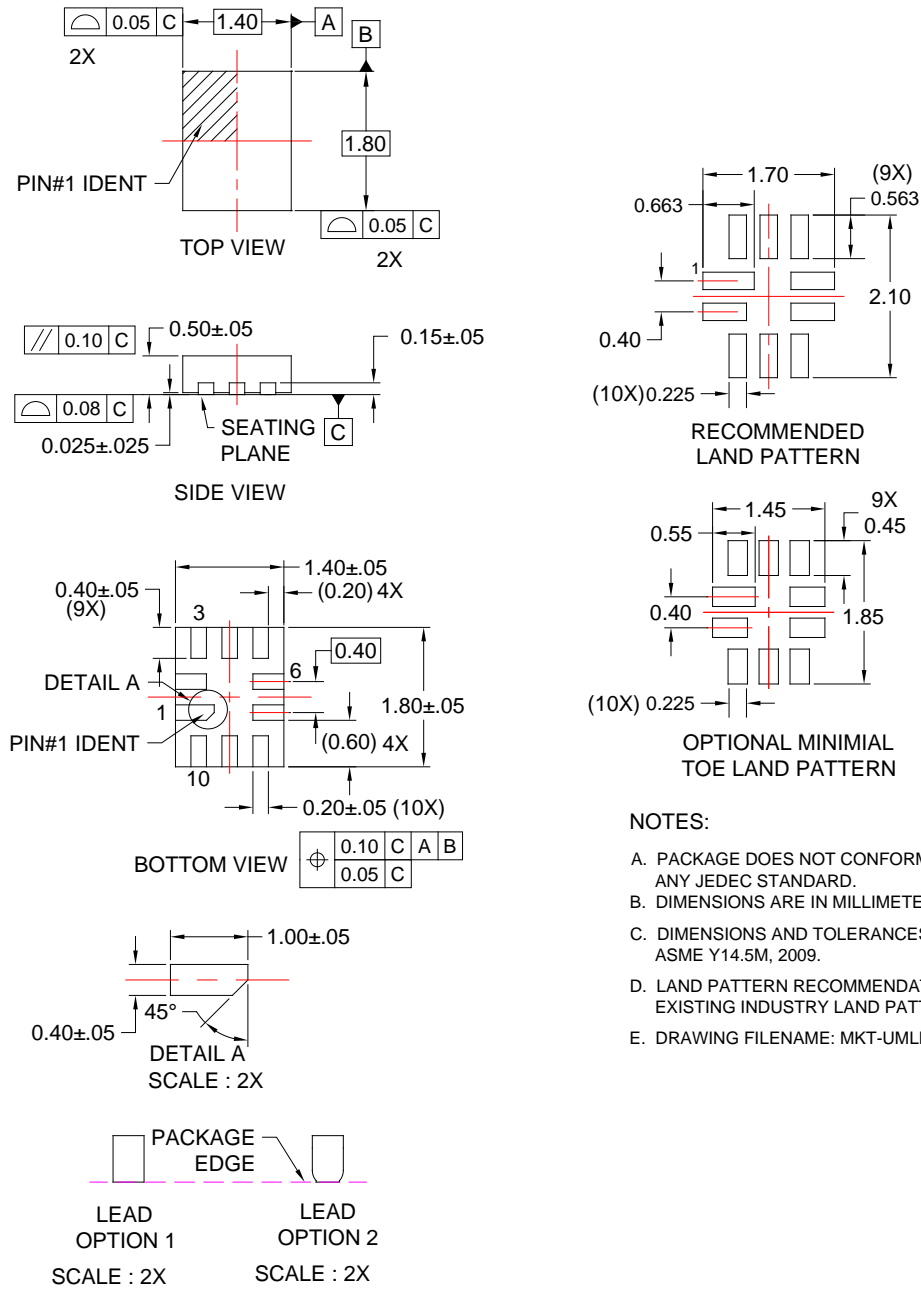

Figure 15. 10-Lead, Ultrathin Molded Leadless Package (UMLP)

ON Semiconductor and the ON Semiconductor logo are trademarks of Semiconductor Components Industries, LLC dba ON Semiconductor or its subsidiaries in the United States and/or other countries. ON Semiconductor owns the rights to a number of patents, trademarks, copyrights, trade secrets, and other intellectual property. A listing of ON Semiconductor's product/patent coverage may be accessed at www.onsemi.com/site/pdf/Patent-Marking.pdf. ON Semiconductor reserves the right to make changes without further notice to any products herein. ON Semiconductor makes no warranty, representation or guarantee regarding the suitability of its products for any particular purpose, nor does ON Semiconductor assume any liability arising out of the application or use of any product or circuit, and specifically disclaims any and all liability, including without limitation special, consequential or incidental damages. Buyer is responsible for its products and applications using ON Semiconductor products, including compliance with all laws, regulations and safety requirements or standards, regardless of any support or applications information provided by ON Semiconductor. "Typical" parameters which may be provided in ON Semiconductor data sheets and/or specifications can and do vary in different applications and actual performance may vary over time. All operating parameters, including "Typicals" must be validated for each customer application by customer's technical experts. ON Semiconductor does not convey any license under its patent rights nor the rights of others. ON Semiconductor products are not designed, intended, or authorized for use as a critical component in life support systems or any FDA Class 3 medical devices or medical devices with a same or similar classification in a foreign jurisdiction or any devices intended for implantation in the human body. Should Buyer purchase or use ON Semiconductor products for any such unintended or unauthorized application, Buyer shall indemnify and hold ON Semiconductor and its officers, employees, subsidiaries, affiliates, and distributors harmless against all claims, costs, damages, and expenses, and reasonable attorney fees arising out of, directly or indirectly, any claim of personal injury or death associated with such unintended or unauthorized use, even if such claim alleges that ON Semiconductor was negligent regarding the design or manufacture of the part. ON Semiconductor is an Equal Opportunity/Affirmative Action Employer. This literature is subject to all applicable copyright laws and is not for resale in any manner.

PUBLICATION ORDERING INFORMATION

LITERATURE FULFILLMENT:

Literature Distribution Center for ON Semiconductor
 19521 E. 32nd Pkwy, Aurora, Colorado 80011 USA
Phone: 303-675-2175 or 800-344-3860 Toll Free USA/Canada
Fax: 303-675-2176 or 800-344-3867 Toll Free USA/Canada
Email: orderlit@onsemi.com

N. American Technical Support: 800-282-9855 Toll Free
 USA/Canada.
Europe, Middle East and Africa Technical Support:
 Phone: 421 33 790 2910
Japan Customer Focus Center
 Phone: 81-3-5817-1050

ON Semiconductor Website: www.onsemi.com
Order Literature: <http://www.onsemi.com/orderlit>

For additional information, please contact your local Sales Representative