

REVISIONS

P	LTR	DESCRIPTION	DATE	DWN	APVD
	A	INITIAL RELEASE	07SEP2022	SD	CD

1. MATERIALS AND FINISH:
 -POWER CONTACTS: COPPER ALLOY, FINISH: Ag OVER Ni
2. ALL MATERIALS MUST COMPLY WITH DIRECTIVE 2011/65/EU AND ITS AMENDMENTS (ROHS)
3. ALL MATERIALS MUST COMPLY WITH REGULATION (EC) NO 1907/2006 (REACH)
4. THIS PRODUCT HAS NOT COMPLETED VALIDATION TESTING
5. CRIMP WITH DANIELS MANUFACTURING TOOL PART NUMBER: M305 AND CONTACT POSITION HEAD PART NUMBER: TP1846
 CRIMP SETTINGS:
 10AWG: POSITION #5
 8 AWG: POSITION #6

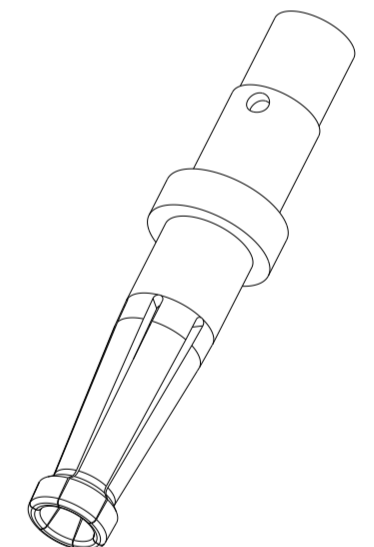
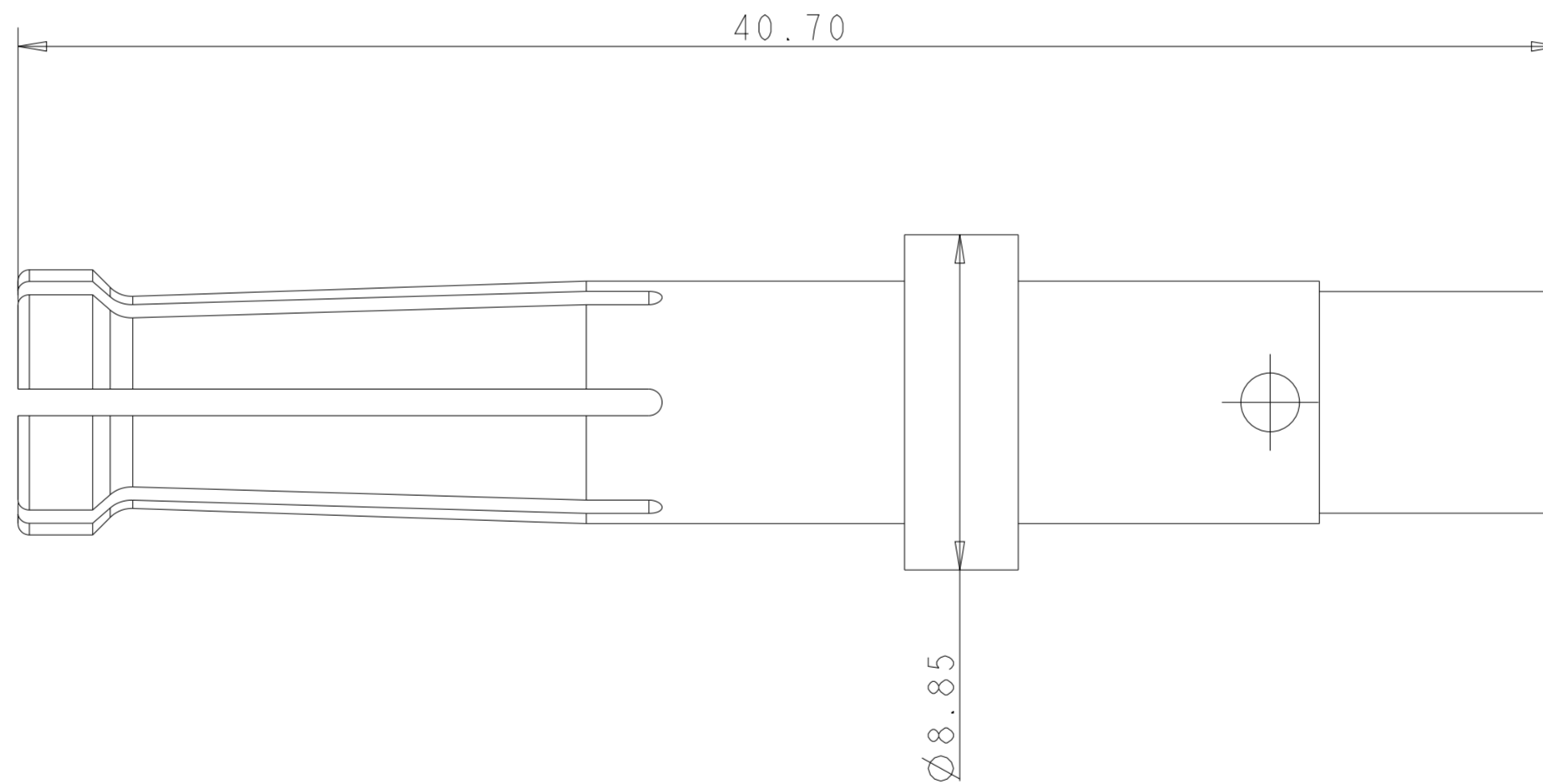
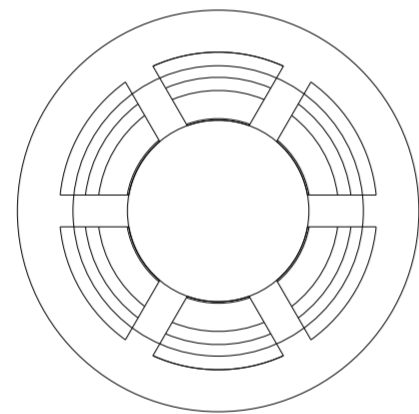

2390328-1
 PART NO.

THIS DRAWING IS A CONTROLLED DOCUMENT.		DWN C. DAILY 23SEP2021	STE TE Connectivity	
		CHK C. DAILY 23SEP2021		
DIMENSIONS: mm	TOLERANCES UNLESS OTHERWISE SPECIFIED:	APVD -	NAME SOCKET CONTACT, DIA. 3.6, 8/10AWG DOCKING	
	0 PLC ± 1 PLC ±0.2 2 PLC ±0.10 3 PLC ± 4 PLC ±	PRODUCT SPEC -	SIZE A200779	
MATERIAL	FINISH -	APPLICATION SPEC -	DRAWING NO C-2390328	RESTRICTED TO -
		WEIGHT -	SCALE 4:1	SHEET 1 OF 1
		CUSTOMER DRAWING	REV A	