

M5223L/P/FP

DUAL SINGLE POWER SUPPLY OPERATIONAL AMPLIFIERS

DESCRIPTION

The M5223 are semiconductor integrated circuits designed as dual operational amplifiers which permit single power supply operation.

The devices come in a compact 8-pin SIP, DIP or FP and contain two circuits for yielding a high internal phase compensation and high performance. For both input and output, operation is possible from the GND level and this makes it possible for the device to be used widely as a general-purpose operational amplifier in the motor control circuits of such equipment as cassette decks, turntables, VTRs and digital audio disc players as well as in automotive electronic products and communications equipment. It can also be employed as a simple comparator.

FEATURES

- Wide common input voltage range and operation permitted with GND level input $V_i = -0.3V \sim +36V$
- Output voltage level can be reduced to near the GND level
- Wide operating supply voltage range and single power supply operation possible $V_{CC} = 3V \sim 36V (V_{CCmax})$
- High voltage gain $G_{V0} = 100dB (typ.)$
- High allowable power dissipation $P_d = 800mW (SIP)$
 $P_d = 625mW (DIP)$
 $P_d = 440mW (FP)$

APPLICATION

General-purpose amplifier in control circuits of cassette decks, turntable, VTRs, video disc players and audio disc players; general-purpose amplifier in automotive electronic products, communications equipment and copying machines.

General-purpose amplifier in radio-controlled and electronic toys, and electronic games.

PIN CONFIGURATION (TOP VIEW)

SIP

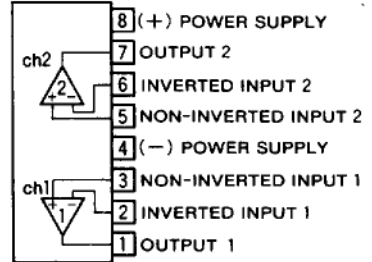

Outline 8P5 (L)

DIP, MINI FLAT

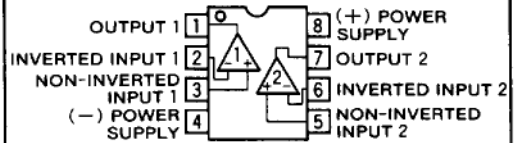

Outline 8P4 (P)
8P2S-A (FP)

BLOCK DIAGRAM

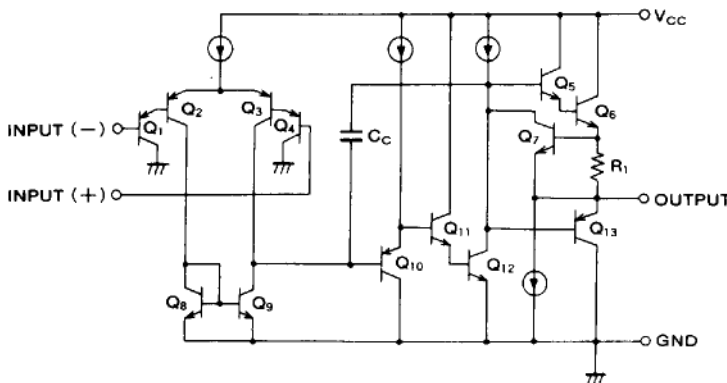

* Two circuits are featured in the circuit on the left.

DUAL SINGLE POWER SUPPLY OPERATIONAL AMPLIFIERS

ABSOLUTE MAXIMUM RATINGS ($T_a=25^\circ\text{C}$, unless otherwise noted)

Symbol	Parameter	Conditions	Ratings	Unit
V_{CC}	Supply voltage		36(± 18)	V
I_{sink}	Load current		± 50	mA
I_{source}				mA
V_{id}	Differential input voltage		± 36	V
V_i	Input voltage		$-0.3 \sim +36$	V
P_d	Power dissipation		800(SIP)/625(DIP)/440(FP)	mW
K_θ	Thermal derating	$T_a \geq 25^\circ\text{C}$	8(SIP)/6.25(DIP)/4.4(FP)	mW/ $^\circ\text{C}$
T_{opr}	Ambient temperature		$-20 \sim +75$	$^\circ\text{C}$
T_{stg}	Storage temperature		$-55 \sim +125$	$^\circ\text{C}$

ELECTRICAL CHARACTERISTICS ($T_a=25^\circ\text{C}$, $V_{CC}=+5\text{V}$)

Symbol	Parameter	Test conditions	Limits			Unit
			Min.	Typ.	Max.	
I_{CC}	Circuit current	$V_{in}=0$		0.7	1.2	mA
V_{IO}	Input offset voltage	$R_S=50\Omega, V_{CM}=7.5\text{V}$		2	7	mV
I_{IO}	Input offset current	$ I_{B(+)} - I_{B(-)} , V_{CM}=7.5\text{V}$		5	50	nA
I_{IB}	Input bias current	$V_{CM}=7.5\text{V}$		30	250	nA
CSR	Channel separation	$f=1\text{kHz}$		120		dB
G_{VO}	Open loop voltage gain	$R_L \geq 2\text{k}\Omega, V_{CM}=7.5\text{V}$	90	100		dB
V_{OH}	Maximum output voltage	$R_L \geq 2\text{k}\Omega$	12.0	13.5		V
V_{OL}		$R_L \geq 2\text{k}\Omega$		0.9	1.8	
V_{CM}	Common phase input voltage width	$R_S=1\text{k}\Omega, f=100\text{Hz}$	-0.3		$+13.5$	V
CMRR	Common phase rejection ratio	$R_S=50\Omega, V_{CM}=7.5\text{V}$		85		dB
SVRR	Supply voltage rejection ratio	$R_S=50\Omega$		100		dB
P_d	Power dissipation			3.5	6.0	mW
SR	Slew rate	$G_V=0\text{dB}, R_L=2\text{k}\Omega$		0.6		V/ μs
I_{source}	Output source current	$V_{IN(-)}=0\text{V}, V_{IN(+)}=1\text{V}$		20	40	mA
I_{sink}	Output sink current	$V_{IN(-)}=1\text{V}, V_{IN(+)}=0\text{V}$		10	20	mA

TYPICAL CHARACTERISTICS

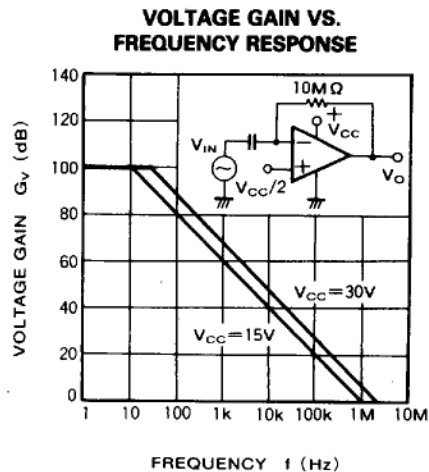
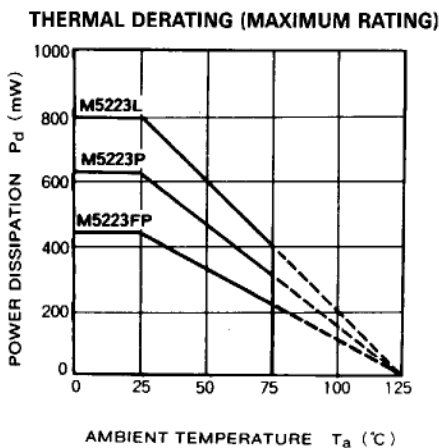

6249826 0021543 316



DUAL SINGLE POWER SUPPLY OPERATIONAL AMPLIFIERS

CIRCUIT CURRENT VS. SUPPLY VOLTAGE

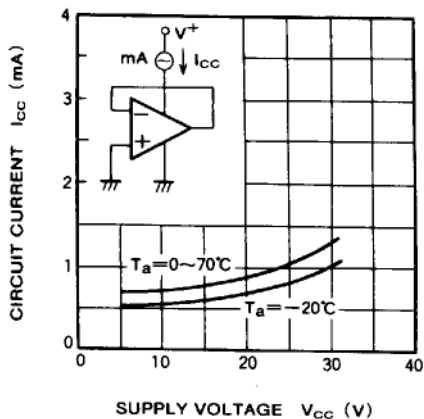

INPUT BIAS CURRENT VS. SUPPLY VOLTAGE

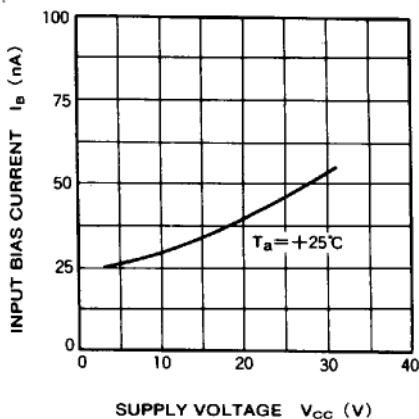

VOLTAGE GAIN VS. SUPPLY VOLTAGE

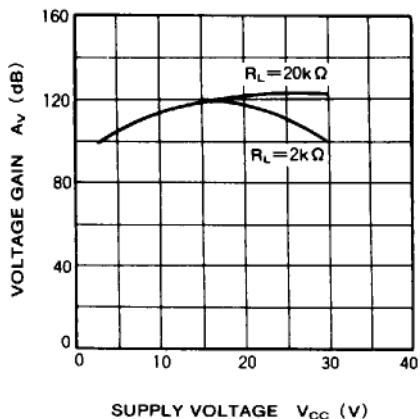

MAXIMUM OUTPUT CURRENT VS. AMBIENT TEMPERATURE

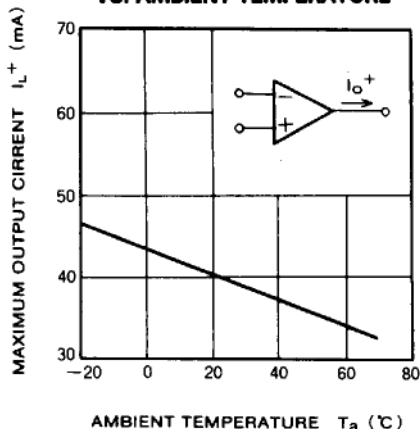

MAXIMUM OUTPUT VOLTAGE VS. FREQUENCY RESPONSE

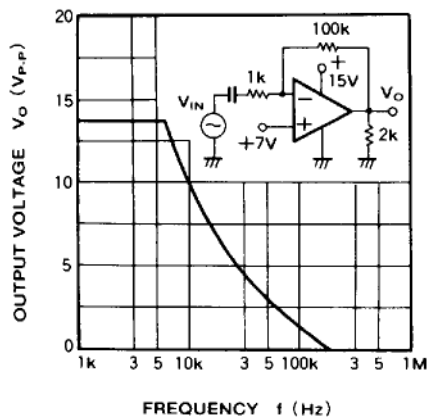

INPUT VOLTAGE / OUTPUT VOLTAGE VS. TIME

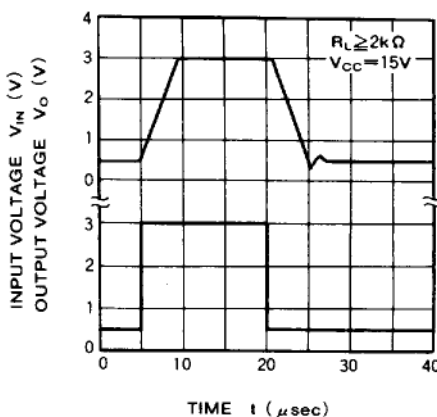

DUAL SINGLE POWER SUPPLY OPERATIONAL AMPLIFIERS

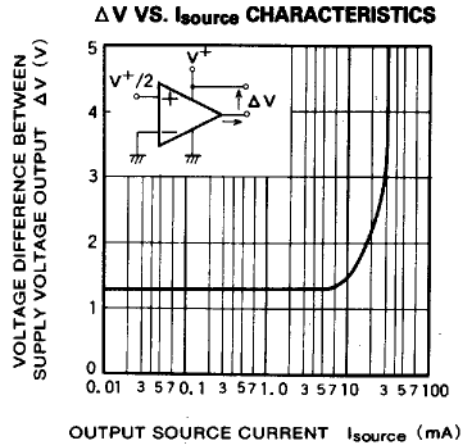
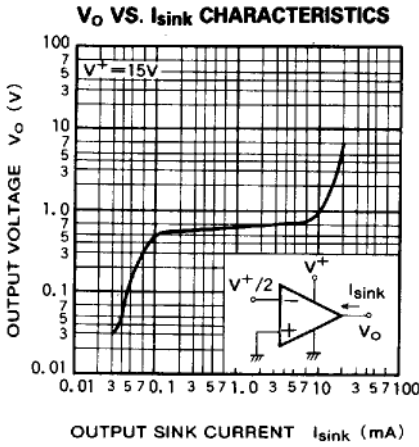

BASIC OPERATION OF SINGLE POWER SUPPLY OPERATIONAL AMPLIFIER

The M5223 is an operational amplifier that operates from 0V (GND) level for both input and output if used at a single power supply voltage.

Basic operation of the device is explained in the following, comparing characteristics of the operational amplifier M5218.

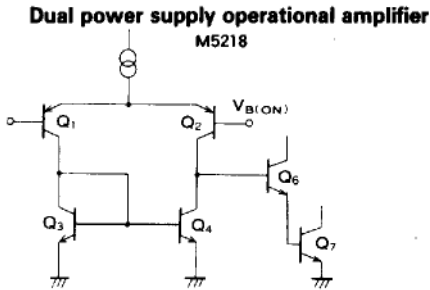

Fig. 1

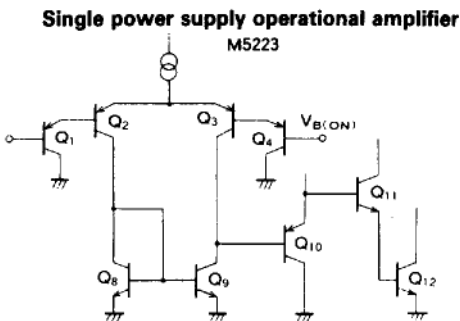

Fig. 2

Fig. 1 illustrates the dual power supply operational amplifier M5218, and Fig. 2 illustrates an input differential circuit of the single power supply operational amplifier M5223. In this case, the input stage base voltage V_{B(ON)} for operating an input differential circuit in the M5218 is as follows;

$$V_{B(ON)} = V_{BE7} + V_{BE6} + V_{CE2} - V_{BE2}$$

(If V_{BE} ≅ 0.6V, V_{CE} ≅ 0.5V)

$$≅ 1.1V$$

and, in the M5223,

$$V_{B(ON)} = V_{BE12} + V_{BE11} - V_{BE10} + V_{CE3} - V_{BE3} - V_{BE4}$$

$$≅ -0.1V$$

and, in the M5223, the differential circuit is activated even when the input level is 0V. The input and output characteristics are shown in Fig. 3.

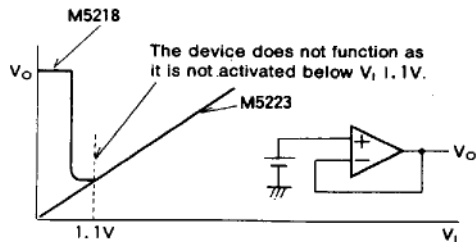

Fig. 3

Operation of an output stage is explained in the following.

DUAL SINGLE POWER SUPPLY OPERATIONAL AMPLIFIERS

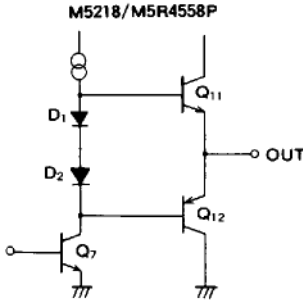

Fig. 4

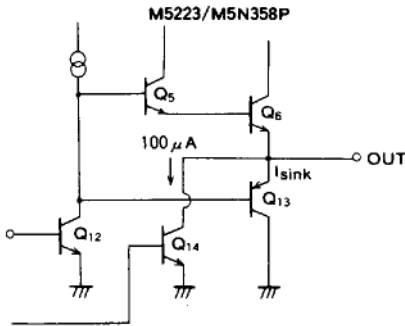

Fig. 5

Fig. 4 illustrates an output stage of the M5218, which adopts an AB-class push-pull circuit of ordinary operational amplifier output type, where no crossover distortion occurs because idling current is running from D₁, D₂ bias to Q₁₁, Q₁₂ in quiescent state. In this case, the output never goes below the level of V_{BE12}+V_{CE7}, and the device is activated up to a voltage of approximately 1.1V. Moreover, the voltage changes greatly according to conditions of load current.

Fig. 5 illustrates the M5223, to which rated current circuit of I_c≅100μA is connected by Q₁₄ and the output can be reduced to near GND level as A-class bias output stage up to the current of 100μA. For a load in excess of this current, in case of the M5223 driven by Q₁₃, no idling current is present because of C-class bias (where the base of output transistors Q₅, Q₆, Q₁₃ are shorted), and crossover distortion occurs. Therefore, the device may not be suitable for audio signal amplifiers.

Both single and dual power supply amplifiers operate exactly with the same operating circuit logic (activation level of input and output and load driving methods are different), but bias must be set at V_{CC}/2 for output DC current in both single and dual power supply amplifiers.

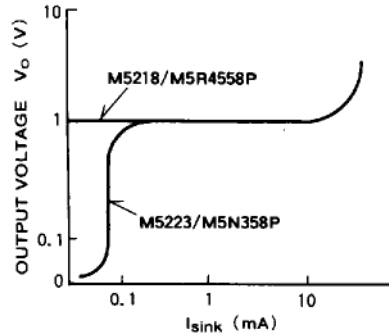

Fig. 6

REDUCTION OF DISTORTION IN A SINGLE POWER SUPPLY OPERATIONAL AMPLIFIER

As has been explained previously, a single power supply operational amplifier operates with low distortion as an A-class bias circuit up to a load condition that can be driven by current (100 μA) in a rated current circuit which is built in the output stage, and it can be used for audio signals but, if the load condition exceeds the value of current, the device is placed into a C-class bias condition, and crossover distortion occurs. To reduce this distortion, a pull-up resistor (e.g. 3k Ω) for running A-class bias current externally can be connected as shown in Fig. 7 to increase the A-class bias current and reduce distortion. (Refer to Fig. 8 DISTORTION VS OUTPUT VOLTAGE.)

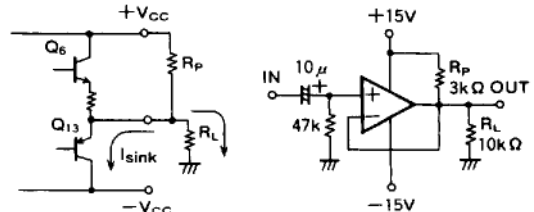

Fig. 7 (Explanation by dual power supply method)

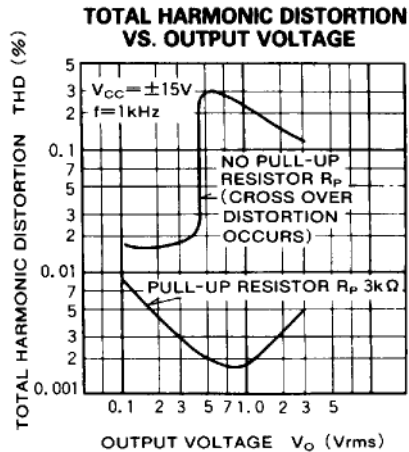

Fig. 8