

Data Sheet | Item Number: 216-105

Ferrule

<https://www.wago.com/216-105>

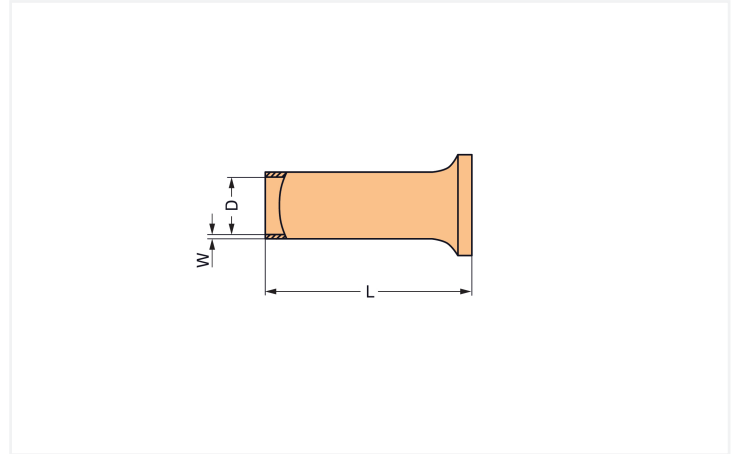

Dimensions in mm

Connection Data

Metric cross-section of the ferrule	2.5 mm ²
Strip length	8 mm / 0.31 inches
Cross-section (AWG) of ferrule	14 AWG

Physical data

Total length	8 mm
Wall thickness of crimp sleeve	0.2 mm
Diameter crimp sleeve inside	2.1 mm

Mechanical data

Plastic collar	No
----------------	----

Material data

Weight	0.1 g
--------	-------

Commercial data

PU (SPU)	5000 (1000) pcs
Packaging type	Box
Country of origin	DE
GTIN	4045454996628
Customs tariff number	85369010000

Product Classification

UNSPSC	39121405
ETIM 9.0	EC000005
ETIM 10.0	EC000005
ECCN	NO US CLASSIFICATION

Environmental Product Compliance

RoHS Compliance Status	Compliant, No Exemption
------------------------	-------------------------

Downloads

Environmental Product Compliance

Compliance Search

Environmental Product
Compliance 216-105



Installation Notes

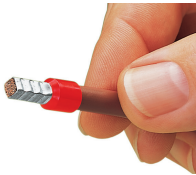

A perfect gas-tight crimp – both electrically
and mechanically reliable