

DASH NO	CABLES ACCOMMODATED	ASSEMBLE PER	A DIA
-7	TRC-50-2/TRC-75-2	TAI-189	.274
-9	TWC-78-2/TWC-124-2	TAI-102	.285
-23	250-3884, MICROOOT	TAI-189	.183
-24	202-3934, MICROOOT	TAI-102	.191
-24A	9530A5117, RAYCHEM	TAI-189	.200
-25	GEE1A, GERMANY	TAI-102	.285
-25A	5021H5331, RAYCHEM	TAI-189	.285
-26	702BA5518, RAYCHEM		.183
-27	202-3927, MICROOOT	TAI-102	.145
-29	TWC-78-1/TWC-124-1A		.191
-30	761A,W.E.CO/8441,BELDEN		.235
-32	TRC-50-1	TAI-189	.191
-33	TRC-75-1		.217
-42	21-204, ESSEX 4463, CONSOLIDATED		.300
-43	250-4044/250-4045 293-3930, MICROOOT	TAI-102	.200
-45	M27500-22TE2T14 1100-66F, STANDARD		.183
-47	MI7/176-00002		.164
-49	TWAC-78-1F2	TAI-189	.132
-55	89272, BELDEN		.250
-56	GC875GC1, GRUMMAN		.191
-57	GC875GB1, GRUMMAN	TAI-102	.198
-58	GC875TM24H, GRUMMAN		.198
-59	GC875LN1, GRUMMAN		.198
-60	MI7/177, THERMATICS 380-10045, BOEING	TAI-189	.217
-64	7528A5314, RAYCHEM		.183

REVISIONS			
REV	DESCRIPTIONS	DATE	APPROVED
L	ECO 52611	9/28/10	T. KOHLER

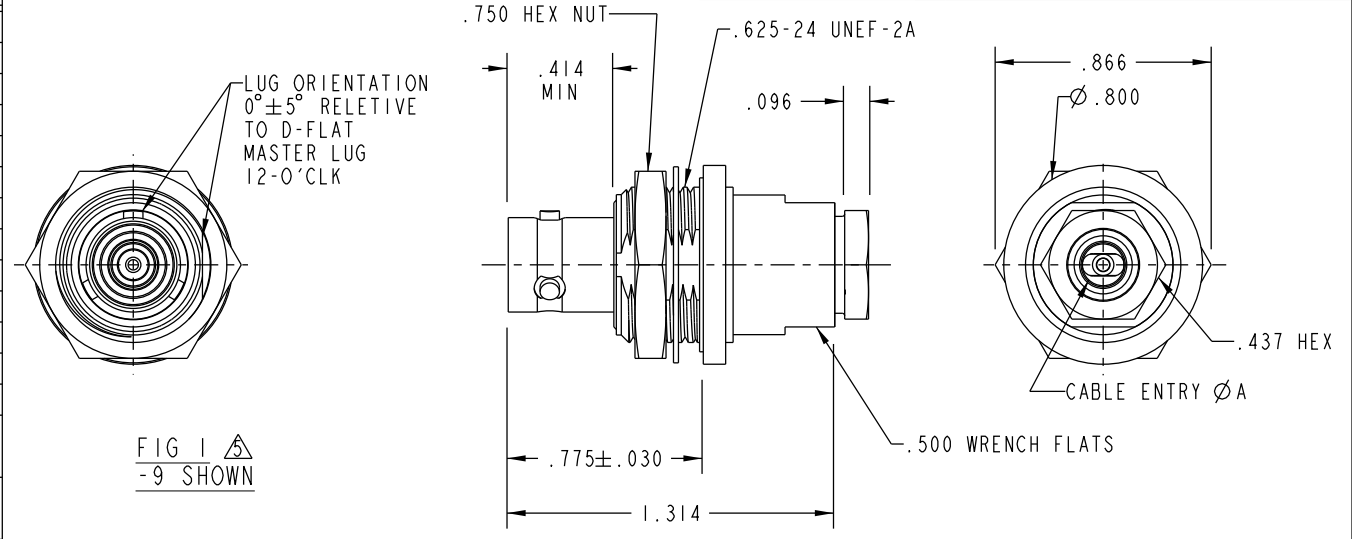

FIG 1 -9 SHOWN

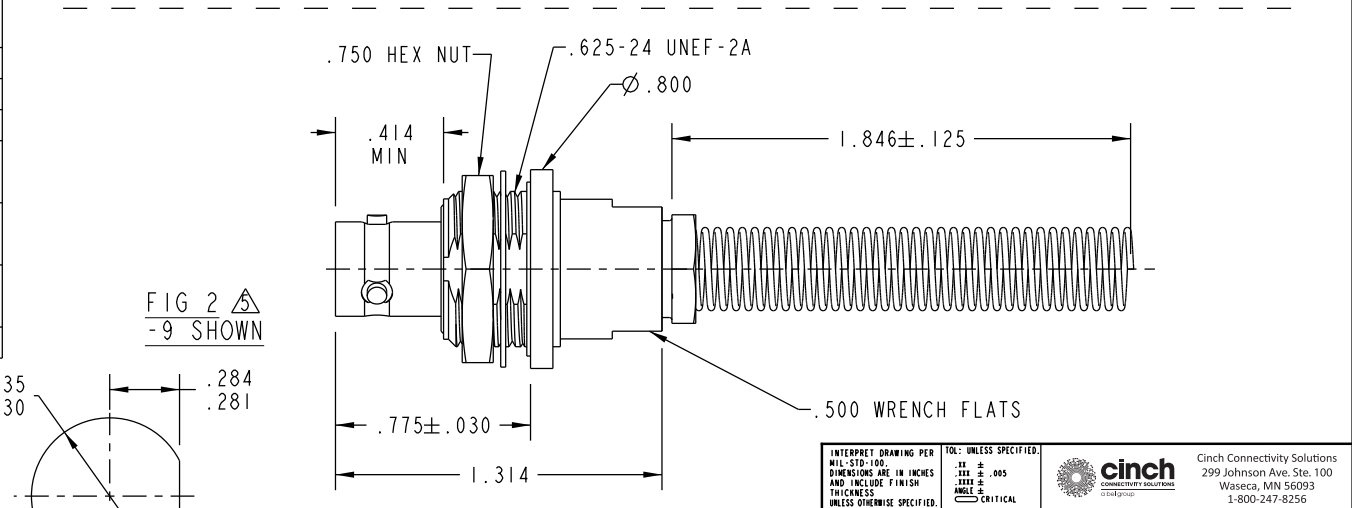
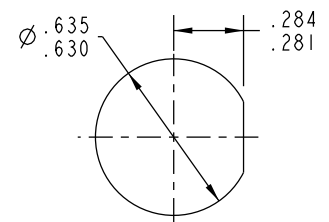

FIG 2 -9 SHOWN

IF BEND RELIEF SPRING REQUIRED (FIG 2)



RECOMMENDED PANEL CUTOUT

4. CONCENTRIC TWINAX/TRIAX TRB BULKHEAD MOUNT CABLE RECEPTACLE
3. MAX PANEL THK .140
2. FINISH: TFS-1A (NICKEL)
1. ALL DIM ARE IN INCHES

NOTES: UNLESS OTHERWISE SPECIFIED.

INTERPRET DRAWING PER MIL-STD-100. DIMENSIONS ARE IN INCHES AND INCLUDE FINISH THICKNESS UNLESS OTHERWISE SPECIFIED.		TOL: UNLESS SPECIFIED.		Cinch Connectivity Solutions 299 Johnson Ave. Ste. 100 Waseca, MN 56093 1-800-247-8256	
DRN: J. CRAWFORD CHG: C. WALLACE QUALITY:	10/19/10 10/19/10	MATERIAL:	TITLE: B J74/B J74BR	SIZE: B CAGE CODE: 14949	DRAWING NO. 3-0055
BLANK LENGTH (REF. ONLY)	APPROVED:	FINISH:	SCALE: 2/1	DATE:	REV. L
SURFACE AREA	PROJ. FILE NO. 3-0055	DO NOT SCALE DWG	SHEET 1 OF 2		