

CIRCUIT SIZE	DIM.A	DIM.B	DIM.C	DIM.D
20	13.90	9.00	12.40	12.22
30	18.90	14.00	17.40	17.22
40	23.90	19.00	22.40	22.22
50	28.90	24.00	27.40	27.22
60	33.90	29.00	32.40	32.22
64	35.90	31.00	34.40	34.22
70	38.90	34.00	37.40	37.22
80	43.90	39.00	42.40	42.22
84	45.90	41.00	44.40	44.22
90	48.90	44.00	47.40	47.22
100	53.90	49.00	52.40	52.22
110	58.90	54.00	57.40	57.22
120	63.90	59.00	62.40	62.22

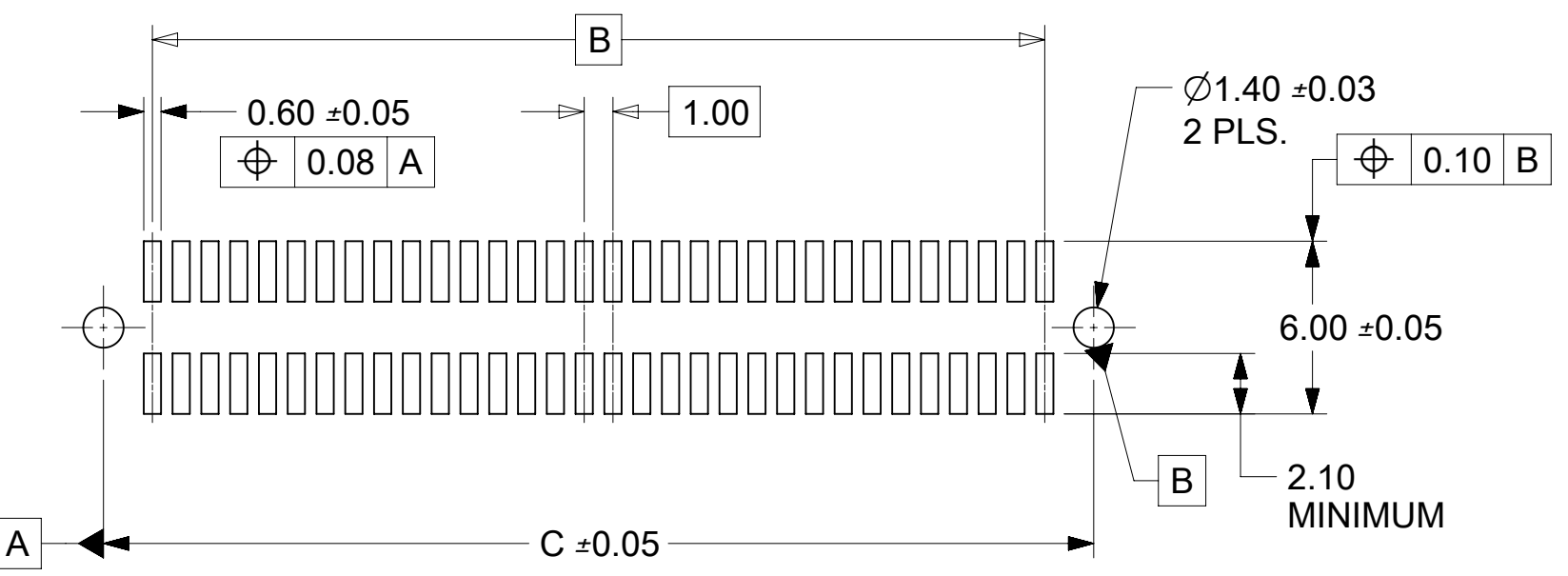
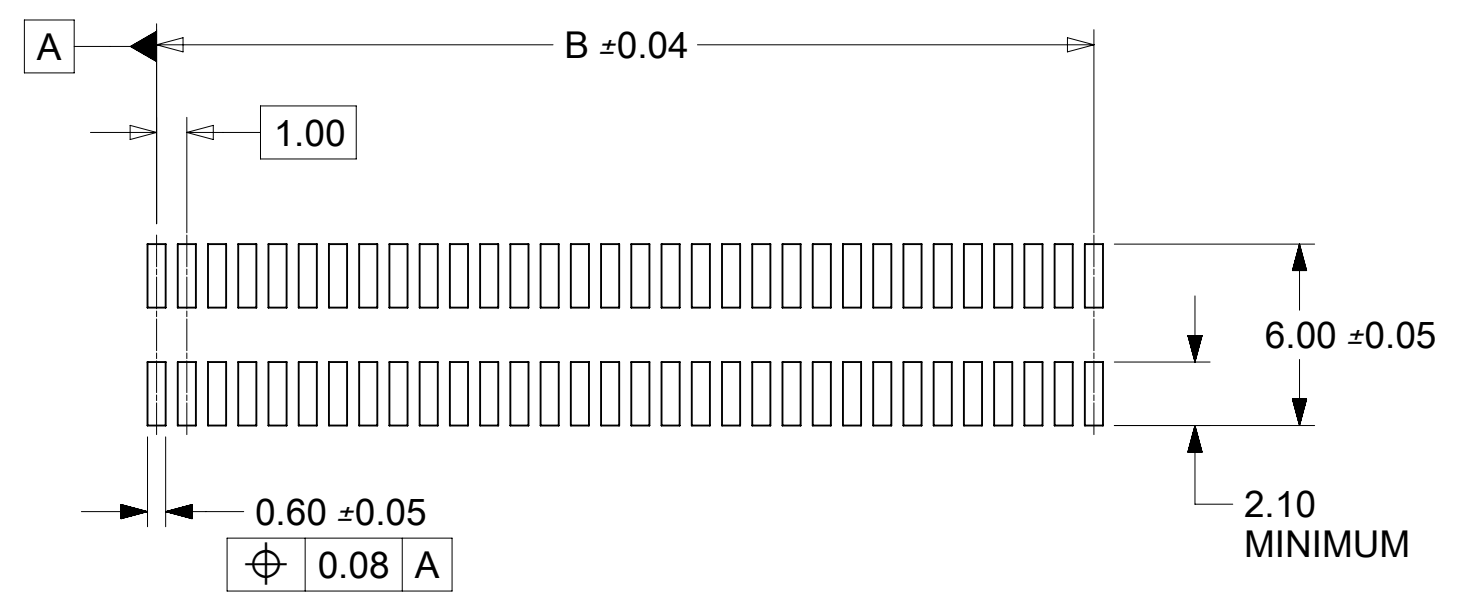

**RECOMMENDED PCB LAYOUT
(WITH AND WITHOUT PEGS)
RECOMMENDED PCB THICKNESS: 1.00±0.10**

NOTES

- HOUSING MATERIAL: LIQUID CRYSTAL POLYMER(LCP) GLASS FILLED; UL RATING; 94V-0; COLOR: WHITE OR BLACK. TERMINAL MATERIAL: PHOSPHOR BRONZE; 0.205 THICK. VACUUM CAP MATERIAL: STAINLESS STEEL; 0.255 THICK.
- PLATING FINISHES: SEE SHEET 2
- PRODUCT SPECIFICATION: PS-71436-999
- PACKAGING SPECIFICATIONS: REFER TO CHART ON SHEET 2.
- MATES WITH: 71436 SERIES. SEE SHEET 2 FOR MATING VIEW AND STACK HEIGHT.
- PEGS ARE OPTIONAL. REFER TO CHART ON SHEET 2.
- VACUUM PICK & PLACE CAP IS OPTIONAL. REFER TO CHART ON SHEET 2.
- THIS PART CONFORMS TO EIA STANDARD 700 AAAB FOR 1.0mm TWO-PART CONNECTORS FOR USE WITH PARALLEL PRINTED BOARDS.
- COPLANARITY OF SMT TAILS: 0.10mm MAXIMUM.
- 64-CIRCUIT RECEPTACLE ASSEMBLY WITH PEGS AND VACUUM CAP SHOWN FOR ILLUSTRATION PURPOSES ONLY.
- ASSEMBLY TO HAVE DATE CODE: XX XX

WEEK _____ YEAR _____

THIS DRAWING CONTAINS INFORMATION THAT IS PROPRIETARY TO MOLEX ELECTRONIC TECHNOLOGIES, LLC AND SHOULD NOT BE USED WITHOUT WRITTEN PERMISSION									
DIMENSION UNITS	SCALE	CURRENT REV DESC: REDRAWN IN NX							
mm	4:1								
GENERAL TOLERANCES (UNLESS SPECIFIED)					SALES ASSY, 1.0MM BOARD TO BOARD RECEPTACLE CONNECTOR 10.30 HIGH				
ANGULAR TOL	± 0.5°	EC NO: 610884			PRODUCT CUSTOMER DRAWING				
4 PLACES	±	DRWN: TTAO03 2019/01/23			DOCUMENT NUMBER				
3 PLACES	±	CHK'D: JKACHLIC 2019/02/01			714393000				
2 PLACES	± 0.13	APPR: JKACHLIC 2019/02/01			DOC TYPE DOC PART REVISION				
1 PLACE	± 0.25	INITIAL REVISION:			PSD 000 A1				
0 PLACES	±	DRWN: REED 1995/04/03			MATERIAL NUMBER CUSTOMER SHEET NUMBER				
DRAFT WHERE APPLICABLE MUST REMAIN WITHIN DIMENSIONS		THIRD ANGLE PROJECTION		DRAWING	SERIES	SEE TABLE		GENERAL MARKET 1 OF 2	
				C-SIZE	71439				

WHITE (NATURAL) MATERIAL

CIRCUIT SIZE	RECEPTACLE ASSY. PART NUMBER	PEGS	CONTACT PLATING (SEE PLATING NOTES)	PICK & PLACE CAP	PACKAGING SPEC. NUMBER	PACKAGING TYPE
64	71439-3164	YES	30 GOLD	NO	PK-70873-0693	TUBE
64	71439-3364	YES	30 GOLD	YES	PK-70873-0693	TUBE
64	71439-3464	YES	30 GOLD	YES	PK-70873-063	TAPE & REEL
64	71439-3564	NO	30 GOLD	NO	PK-70873-0692	TUBE
64	71439-3764	NO	30 GOLD	YES	PK-70873-0692	TUBE
64	71439-3864	NO	30 GOLD	YES	PK-70873-063	TAPE & REEL
64	71439-3264	NO	50 GOLD	YES	PK-70873-063	TAPE & REEL

RECOMMENDED PLUG/RECEPTACLE COMBINATION FOR MATED STACK HEIGHT PER EIA STANDARD 700 AAAB

MATED STACK HEIGHT	RECEPTACLE HEIGHT	RECEPTACLE SERIES NO.	PLUG HEIGHT	PLUG SERIES NO.
14.00	10.30	71439-3***	3.30	71436-1***
15.00	10.30	71439-3***	4.30	71436-2***

PLATING NOTES :

30 GOLD - SELECTIVE GOLD (Au) IN THE CONTACT AREA; THICKNESS = 0.76 MICROMETER MINIMUM ; SELECTIVE TIN (Sn) IN THE CONTACT AREA; THICKNESS = 1.88 MICOMETER MINIMUM; NICKEL UNDERPLATE OVERALL;

50 GOLD - SELECTIVE GOLD (Au) IN THE CONTACT AREA; THICKNESS = 1.27 MICROMETER MINIMUM ; SELECTIVE TIN (Sn) IN THE CONTACT AREA; THICKNESS = 1.88 MICOMETER MINIMUM; NICKEL UNDERPLATE OVERALL;

*THE PRIMARY SHIPPING CARTON WILL BE LABELED "COMPLIANT TO RoHS DIRECTIVE 2002/95/EC AND ELV ANNEX II OF DIRECTIVE 2000/53/EC". CARTONS WITHOUT THIS LABEL MAY CONTAIN PRODUCT WITH LEAD.

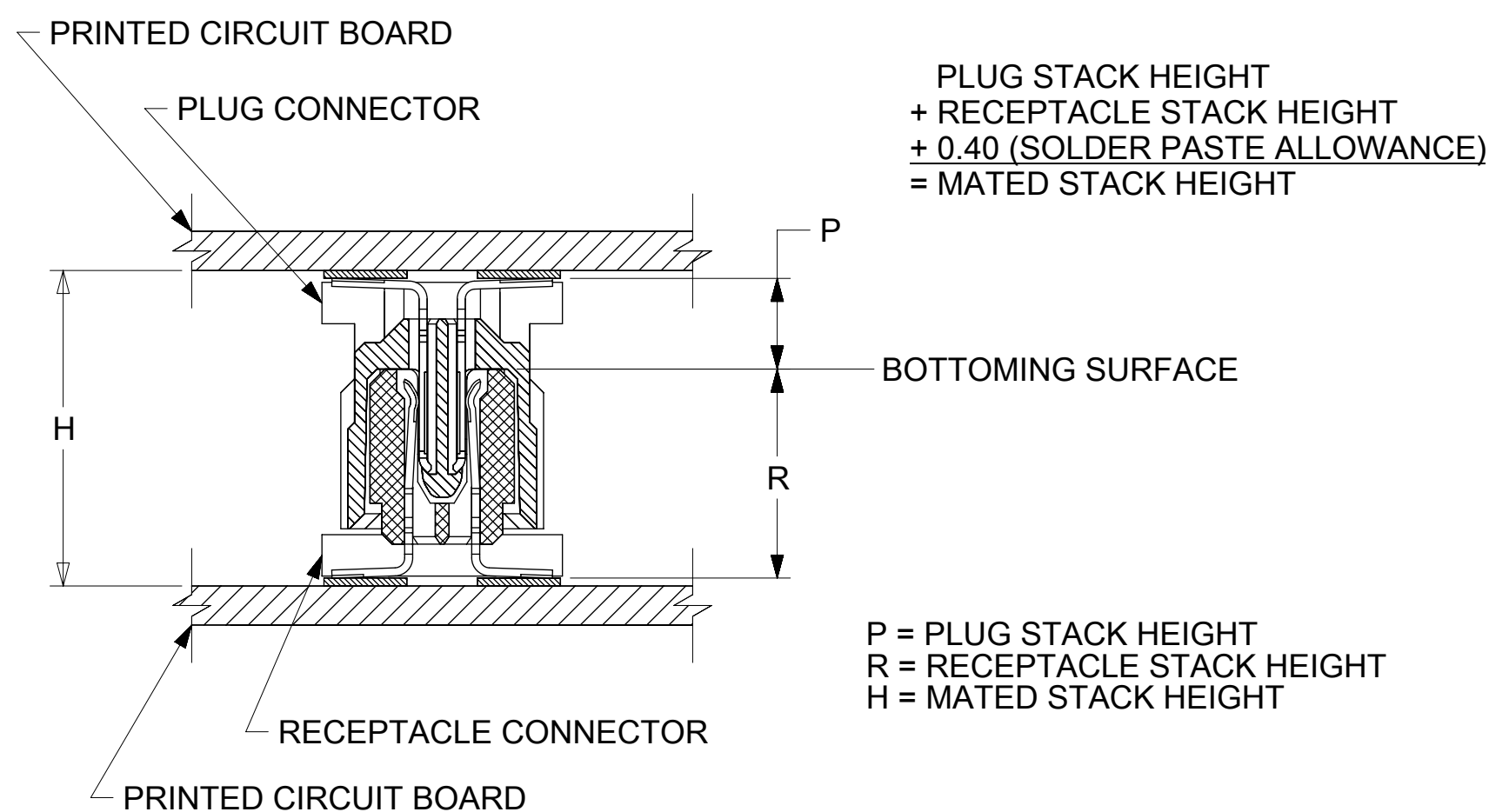

THIS DRAWING CONTAINS INFORMATION THAT IS PROPRIETARY TO MOLEX ELECTRONIC TECHNOLOGIES, LLC AND SHOULD NOT BE USED WITHOUT WRITTEN PERMISSION									
DIMENSION UNITS	SCALE	CURRENT REV DESC: REDRAWN IN NX							
mm	---								
GENERAL TOLERANCES (UNLESS SPECIFIED)		EC NO: 610884			SALES ASSY, 1.0MM BOARD TO BOARD RECEPTACLE CONNECTOR 10.30 HIGH				
ANGULAR TOL	± 0.5°	DRWN: TTAO03 2019/01/23			PRODUCT CUSTOMER DRAWING				
4 PLACES	±	CHK'D: JKACHLIC 2019/02/01			DOCUMENT NUMBER				
3 PLACES	±	APPR: JKACHLIC 2019/02/01			714393000				
2 PLACES	± 0.13	INITIAL REVISION:			DOC TYPE				
1 PLACE	± 0.25	DRWN: REED 1995/04/03			PSD				
0 PLACES	±	APPR: BIXLER 1995/04/03			DOC PART				
DRAFT WHERE APPLICABLE MUST REMAIN WITHIN DIMENSIONS		THIRD ANGLE PROJECTION		DRAWING	SERIES	MATERIAL NUMBER		CUSTOMER	SHEET NUMBER
				C-SIZE	71439	SEE TABLE		GENERAL MARKET	2 OF 2

WHITE (NATURAL) MATERIAL

CIRCUIT SIZE	RECEPTACLE ASSY. ITEM NUMBER	PEGS	CONTACT PLATING (SEE PLATING NOTES)	PICK & PLACE CAP	PACKAGING SPEC. NUMBER	PACKAGING TYPE
64	71439-3164	YES	30 GOLD	NO	PK-70873-0693	TUBE
64	71439-3364	YES	30 GOLD	YES	PK-70873-0693	TUBE
64	71439-3464	YES	30 GOLD	YES	PK-70873-063	TAPE & REEL
64	71439-3564	NO	30 GOLD	NO	PK-70873-0692	TUBE
64	71439-3764	NO	30 GOLD	YES	PK-70873-0692	TUBE
64	71439-3864	NO	30 GOLD	YES	PK-70873-063	TAPE & REEL
64	71439-3264	NO	50 GOLD	YES	PK-70873-063	TAPE & REEL

PLATING NOTES:

30 GOLD: SELECTIVE GOLD (Au) IN THE CONTACT AREA;
THICKNESS = 0.76 MICROMETERS (30 MICROINCHES) MINIMUM;
SELECTIVE TIN (Sn) IN THE PC TAIL AREA;
THICKNESS = 1.88 MICROMETERS (75 MICROINCHES) MINIMUM;
NICKEL UNDERPLATE OVERALL.

50 GOLD: SELECTIVE GOLD (Au) IN THE CONTACT AREA;
THICKNESS = 1.27 MICROMETERS (50 MICROINCHES) MINIMUM;
SELECTIVE TIN (Sn) IN THE PC TAIL AREA;
THICKNESS = 1.88 MICROMETERS (75 MICROINCHES) MINIMUM;
NICKEL UNDERPLATE OVERALL.

*THE PRIMARY SHIPPING CARTON WILL BE LABELED 'COMPLIANT TO RoHS DIRECTIVE 2002/95/EC AND ELV ANNEX II OF DIRECTIVE 2000/53/EC'. CARTONS WITHOUT THIS LABEL MAY CONTAIN PRODUCT WITH LEAD.

RECOMMENDED PLUG/RECEPTACLE COMBINATION FOR MATED STACK HEIGHT PER EIA STANDARD 700 AAAB

MATED STACK HEIGHT	RECEPTACLE HEIGHT	RECEPTACLE SERIES NO.	PLUG HEIGHT	PLUG SERIES NO.
14.00/.551	10.30/.406	71439-3***	3.30/.130	71436-1***
15.00/.591	10.30/.406	71439-3***	4.30/.169	71436-2***

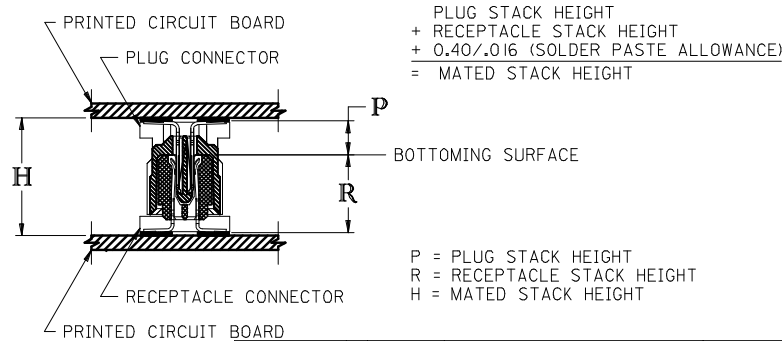

CORRECT DESIGN UNITS	QUALITY SYMBOLS	GENERAL TOLERANCES (UNLESS SPECIFIED)		DIMENSION STYLE		SCALE	DESIGN UNITS	THIRD ANGLE PROJECTION		
		mm	INCH	MM/IN	---	METRIC				
EC NO: UCP2008-2484 DRN:MSI/BARRA 2008/04/22 CHKD:BBARKER 2008/05/06 APPR:SMILLER 2008/05/06	DESCRIPTION REV	4 PLACES	±---	±---	DRAWN BY	DATE	TITLE ASSY 1.0MM BOARD-T-BOARD RECEPTACLE CONNECTOR 10.30/406 STACK HEIGHT			
		3 PLACES	±---	±---	REED	1995/03/23				
		2 PLACES	±---	±---	CHECKED BY	DATE				
		1 PLACE	±---	±---	REED	1995/03/23	APPROVED BY		DATE	
		ANGULAR ±1/2°		BIXLER		1995/03/23		MOLEX INCORPORATED DOCUMENT NO. SDA-71439-3*** SHEET NO. 2 OF 2		
DRAFT WHERE APPLICABLE MUST REMAIN WITHIN DIMENSIONS		SEE TABLE		THIS DRAWING CONTAINS INFORMATION THAT IS PROPRIETARY TO MOLEX INCORPORATED AND SHOULD NOT BE USED WITHOUT WRITTEN PERMISSION						