



CY8CKIT-043

# PSoC<sup>®</sup> 4 M-Series Prototyping Kit Guide

Doc. #: 001-97606 Rev. \*\*

Cypress Semiconductor  
198 Champion Court  
San Jose, CA 95134-1709  
Phone (USA): +1.800.858.1810  
Phone (Intl): +1.408.943.2600  
[www.cypress.com](http://www.cypress.com)

## Copyrights

© Cypress Semiconductor Corporation, 2015. The information contained herein is subject to change without notice. Cypress Semiconductor Corporation assumes no responsibility for the use of any circuitry other than circuitry embodied in a Cypress product. Nor does it convey or imply any license under patent or other rights. Cypress products are not warranted nor intended to be used for medical, life support, life saving, critical control or safety applications, unless pursuant to an express written agreement with Cypress. Furthermore, Cypress does not authorize its products for use as critical components in life-support systems where a malfunction or failure may reasonably be expected to result in significant injury to the user. The inclusion of Cypress products in life-support systems application implies that the manufacturer assumes all risk of such use and in doing so indemnifies Cypress against all charges.

Any Source Code (software and/or firmware) is owned by Cypress Semiconductor Corporation (Cypress) and is protected by and subject to worldwide patent protection (United States and foreign), United States copyright laws and international treaty provisions. Cypress hereby grants to licensee a personal, non-exclusive, non-transferable license to copy, use, modify, create derivative works of, and compile the Cypress Source Code and derivative works for the sole purpose of creating custom software and or firmware in support of licensee product to be used only in conjunction with a Cypress integrated circuit as specified in the applicable agreement. Any reproduction, modification, translation, compilation, or representation of this Source Code except as specified above is prohibited without the express written permission of Cypress.

Disclaimer: CYPRESS MAKES NO WARRANTY OF ANY KIND, EXPRESS OR IMPLIED, WITH REGARD TO THIS MATERIAL, INCLUDING, BUT NOT LIMITED TO, THE IMPLIED WARRANTIES OF MERCHANTABILITY AND FITNESS FOR A PARTICULAR PURPOSE. Cypress reserves the right to make changes without further notice to the materials described herein. Cypress does not assume any liability arising out of the application or use of any product or circuit described herein. Cypress does not authorize its products for use as critical components in life-support systems where a malfunction or failure may reasonably be expected to result in significant injury to the user. The inclusion of Cypress' product in a life-support systems application implies that the manufacturer assumes all risk of such use and in doing so indemnifies Cypress against all charges.

Use may be limited by and subject to the applicable Cypress software license agreement.

PSoC and CapSense are registered trademarks and PSoC Creator, PSoC, and EZ-BLE are trademarks of Cypress Semiconductor Corp. All other trademarks or registered trademarks referenced herein are property of the respective corporations.

## Flash Code Protection

Cypress products meet the specifications contained in their particular Cypress PSoC Data Sheets. Cypress believes that its family of PSoC products is one of the most secure families of its kind on the market today, regardless of how they are used. There may be methods, unknown to Cypress, that can breach the code protection features. Any of these methods, to our knowledge, would be dishonest and possibly illegal. Neither Cypress nor any other semiconductor manufacturer can guarantee the security of their code. Code protection does not mean that we are guaranteeing the product as 'unbreakable'.

Cypress is willing to work with the customer who is concerned about the integrity of their code. Code protection is constantly evolving. We at Cypress are committed to continuously improving the code protection features of our products.

# Contents



<b>Safety Information</b>	<b>5</b>
<b>1. Introduction</b>	<b>7</b>
1.1 Kit Contents .....	7
1.2 PSoC Creator .....	8
1.2.1 PSoC Creator Code Examples .....	9
1.2.2 Kit Code Example .....	10
1.2.3 PSoC Creator Help .....	10
1.3 Getting Started.....	11
1.4 Additional Learning Resources .....	11
1.5 Technical Support.....	12
1.6 Document Conventions .....	12
<b>2. Software Installation</b>	<b>13</b>
2.1 Before You Begin.....	13
2.2 Install Software .....	13
2.3 Uninstall Software.....	15
<b>3. Kit Operation</b>	<b>16</b>
3.1 Theory of Operation.....	16
3.2 KitProg .....	17
3.3 Programming and Debugging the PSoC 4 Target Device .....	17
3.3.1 Programming Using PSoC Creator .....	17
3.3.2 Debugging Using PSoC Creator .....	19
3.3.3 Programming Using PSoC Programmer .....	19
3.4 USB-UART Bridge .....	19
3.5 USB-I2C Bridge .....	19
3.6 Updating the KitProg Firmware.....	19
<b>4. Hardware</b>	<b>20</b>
4.1 Board Details .....	20
4.2 Hardware Details .....	22
4.2.1 Target Board.....	22
4.2.2 KitProg Board.....	23
4.2.3 Power Supply System .....	24
4.2.4 Board Separation (Snapping).....	24
4.2.5 Header Connections .....	25
4.2.6 User and Passive Inputs .....	28
4.2.7 EZ-BLE PSoC Module .....	30

<b>5. Code Examples</b>	<b>33</b>
5.1 Using the Kit Code Example .....	33
5.2 Using Built-in PSoC Creator Code Examples with the Kit .....	37
<b>Appendix</b>	<b>42</b>
PSoC 4 M-Series Prototyping Kit Schematics .....	42
Programming the PSoC 4 M-Series Prototyping Kit Using MiniProg3/KitProg .....	44
Bill of Materials .....	45
<b>Revision History</b>	<b>47</b>

# Safety Information



## Regulatory Compliance

The CY8CKIT-043 PSoC<sup>®</sup> 4 M-Series Prototyping Kit is intended for use as a development platform for hardware or software in a laboratory environment. The board is an open system design, which does not include a shielded enclosure. This may cause interference to other electrical or electronic devices in close proximity. In a domestic environment, this product may cause radio interference. In such cases, take adequate preventive measures. In addition, this board should not be used near any medical equipment or RF devices.

Attaching additional wiring to this product or modifying the product operation from the factory default may affect its performance and cause interference with other apparatus in the immediate vicinity. If such interference is detected, suitable mitigating measures should be taken.

The CY8CKIT-043 PSoC 4 M-Series Prototyping Kit, as shipped from the factory, has been verified to meet with requirements of CE as a Class A product.



The kit contains ESD-sensitive devices. Electrostatic charges readily accumulate on the human body and any equipment, and can discharge without detection. Permanent damage may occur on devices subjected to high-energy discharges. Proper ESD precautions are recommended to avoid performance degradation or loss of functionality. Store unused kit boards in the protective shipping package.



### End-of-Life/Product Recycling

This kit has an end-of life five years from the date of manufacture mentioned on the back of the box. Contact your nearest recycler to dispose the kit.

## General Safety Instructions

### ESD Protection

ESD can damage boards and associated components. Cypress recommends that you perform procedures only at an ESD workstation. If such a workstation is not available, use appropriate ESD protection by wearing an antistatic wrist strap attached to the chassis ground (any unpainted metal surface) on your board when handling parts.

### Handling Boards

The CY8CKIT-043 PSoC 4 M-Series Prototyping boards are sensitive to ESD. Hold the board only by its edges. After removing the board from its box, place it on a grounded, static-free surface. Use a conductive foam pad if available. Do not slide board over any surface.

# 1. Introduction



Thank you for your interest in the CY8CKIT-043 PSoC® 4 M-Series Prototyping Kit. This kit is designed as an easy-to-use and inexpensive prototyping platform. It supports the PSoC 4 M-Series device family, delivering a complete system solution for a wide range of embedded applications at a very low cost. The PSoC 4200M device is an expansion of the PSoC 4 device family, which offers more flash, GPIOs, and programmable analog and digital blocks. The PSoC 4200M device is a true programmable embedded system-on chip, integrating custom analog and digital peripheral functions, memory, and an ARM® Cortex®-M0 microcontroller on a single chip. The programmable analog and digital peripheral functions allow higher flexibility, in-field tuning of the design, and faster time-to-market.

The PSoC 4 M-Series Prototyping Kit offers an open footprint breakout board to maximize the end-utility of the PSoC 4200M device. This kit provides a low-cost alternative to device samples while providing a platform to easily develop and integrate the PSoC 4200M device into your end-system. In addition, the board includes the following features:

- Onboard CMOD capacitors to enable CapSense® development
- Bypass capacitors to ensure high-quality ADC conversions
- An LED to provide feedback
- A push button to provide a simple user input
- Load capacitors to connect the 32-kHz external crystal oscillator
- 3.3-V to 5.5-V operation

The PSoC 4 M-Series Prototyping Kit also integrates the Cypress KitProg, which enables onboard programming, debugging, and bridging functionality, such as USB-UART and USB-I<sup>2</sup>C. The KitProg is used to program and debug the target PSoC 4200M device (see [Figure 1-1](#)). The prototyping kit allows you to separate the KitProg board from the PSoC 4 M-Series target board.

## 1.1 Kit Contents

This kit contains only the PSoC 4 M-Series Prototyping Kit board.

Figure 1-1. CY8CKIT-043 PSoC 4 M-Series Prototyping Kit

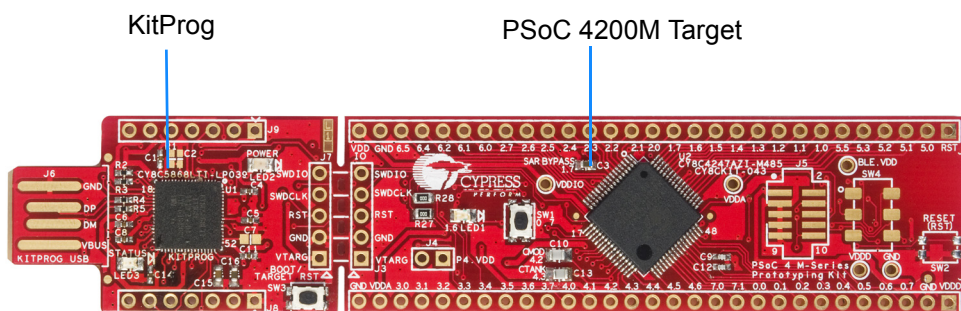

## 1.2 PSoC Creator

PSoC Creator™ is a state-of-the-art, easy-to-use integrated design environment (IDE). It introduces revolutionary hardware and software co-design, powered by a library of preverified and precharacterized PSoC Components. With PSoC Creator, you can:

1. Drag and drop Components to build your hardware system design in the main design workspace
2. Codesign your application firmware with the PSoC hardware
3. Configure Components using configuration tools
4. Explore the library of 100+ Components
5. Review Component datasheets

Figure 1-2. PSoC Creator Features

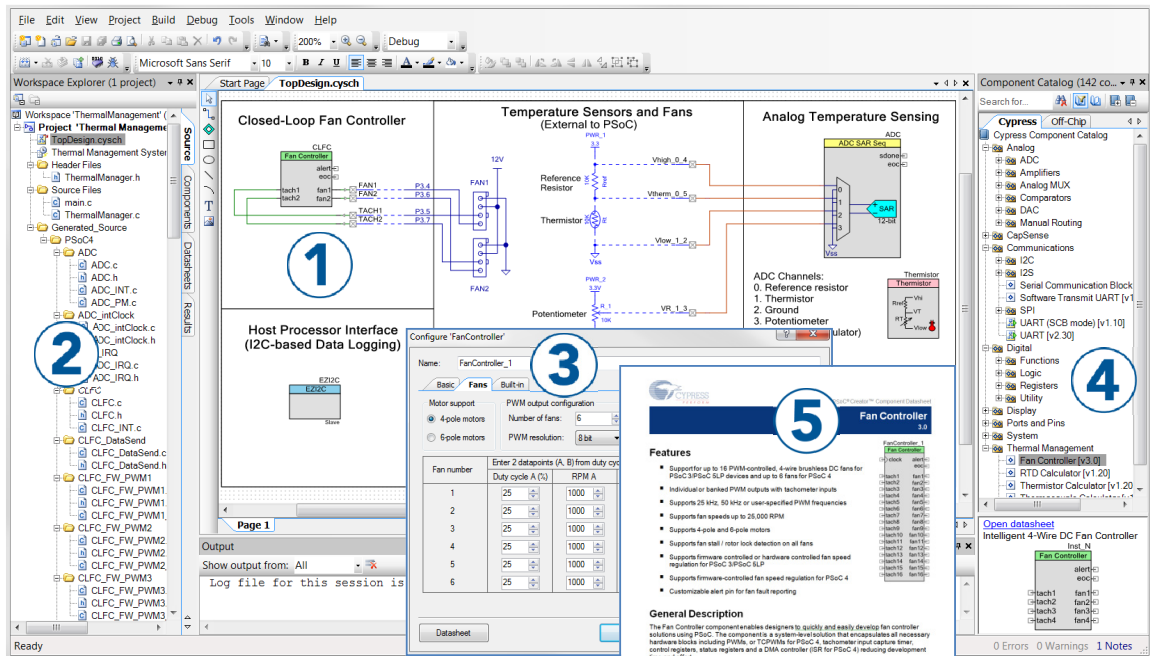

PSoC Creator also enables you to tap into an entire tool ecosystem with integrated compiler chains and production programming programmers for PSoC devices.

For more information, visit [www.cypress.com/psoccreator](http://www.cypress.com/psoccreator). Visit [PSoC Creator training page](#) for video tutorials on learning and using PSoC Creator.

### 1.2.1 PSoC Creator Code Examples

PSoC Creator includes a large number of code examples. These examples are available from the PSoC Creator Start Page, as [Figure 1-3](#) shows.

Code examples can speed up your design process by starting you off with a complete design, instead of a blank page. The code examples also show how PSoC Creator Components can be used for various applications. Code examples and documentation are included, as shown in [Figure 1-4 on page 10](#).

In the **Find Example Project** dialog shown in [Figure 1-4](#), you have several options:

- Filter for examples based on architecture or device family, that is, PSoC 3, PSoC 4, or PSoC 5LP; project name; or keyword.
- Select from the menu of examples offered based on the **Filter Options**.
- Review the example project's description (on the **Documentation** tab).
- Review the code from the **Sample Code** tab. You can copy the code from this window and paste to your project, which can help speed up code development.
- Create a new project (and a new workspace if needed) based on the selection. This can speed up your design process by starting you off with a complete, basic design. You can then adapt that design to your application.

Figure 1-3. Code Examples in PSoC Creator

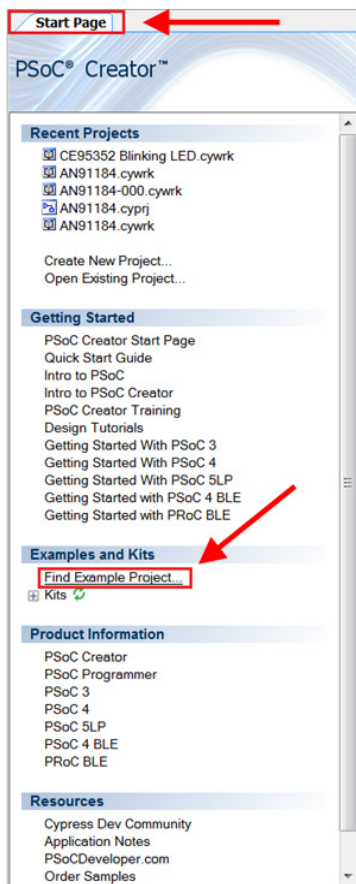
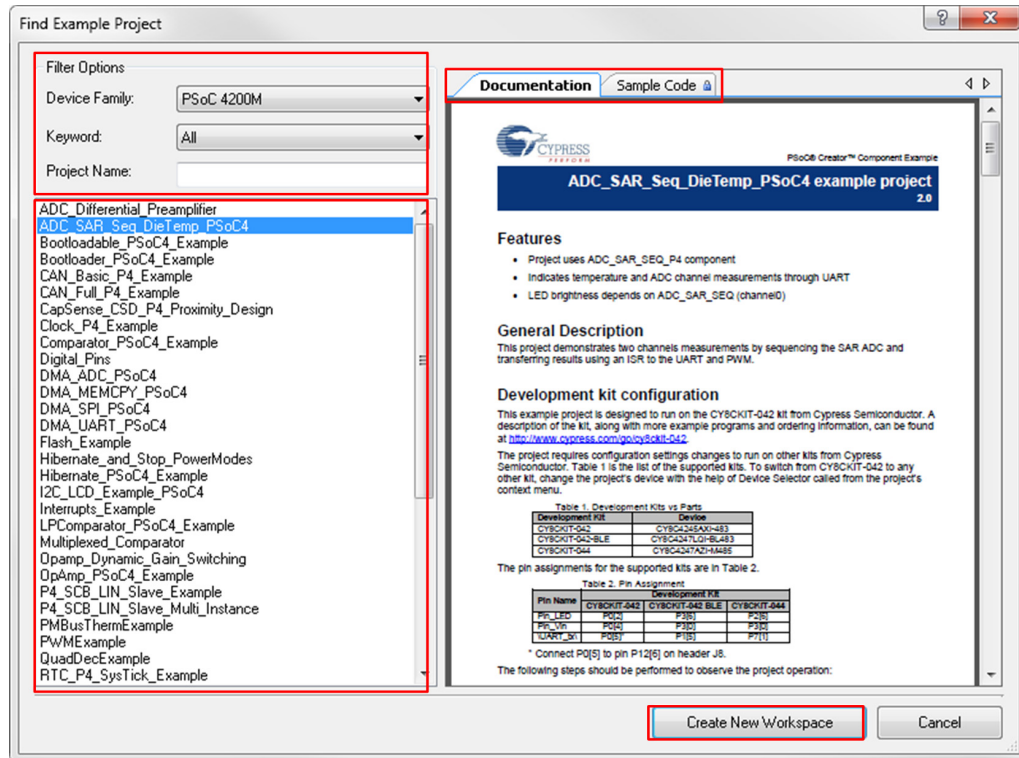

Figure 1-4. Code Example Projects with Sample Code



### 1.2.2 Kit Code Example

In addition to the examples built into PSoC Creator, this kit includes a simple example, which can be used to quickly evaluate the functionality of this kit. The example is described in the [Code Examples chapter on page 33](#). In addition, the chapter also includes a section explaining how to use PSoC Creator code examples with the kit by taking one example.

### 1.2.3 PSoC Creator Help

Visit the [PSoC Creator home page](#) to download the latest version of PSoC Creator. Then, launch PSoC Creator and navigate to the following items:

- **Quick Start Guide:** Choose **Help > Documentation > Quick Start Guide**. This guide gives you the basics for developing PSoC Creator projects.
- **Simple Component example projects:** Choose **File > Example project...**. These example projects demonstrate how to configure and use PSoC Creator Components.
- **Starter designs:** Choose **File > New > Project > PSoC 4100M / PSoC 4200M Starter Designs**. These starter designs demonstrate the unique features of the PSoC 4 M-Series.
- **System Reference Guide:** Choose **Help > System Reference Guides**. This guide lists and describes the system functions provided by PSoC Creator.
- **Component datasheets:** Right-click a Component and select **Open Datasheet**, as shown in [Figure 1-5 on page 11](#). Visit the [PSoC 4 Component Datasheets](#) page for a list of all PSoC 4 Component datasheets.
- **Document Manager:** PSoC Creator provides a document manager to help you to easily find and review document resources. To open the document manager, choose the menu item **Help > Document Manager**.

Figure 1-5. Opening Component Datasheet

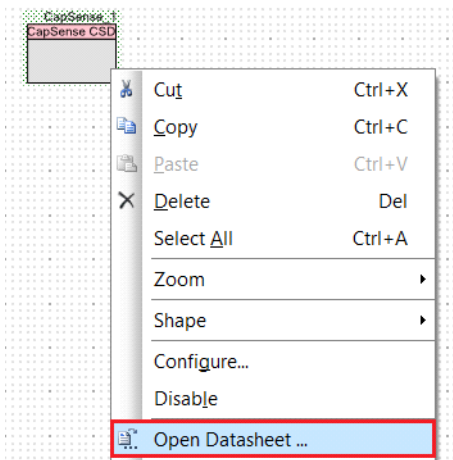

## 1.3 Getting Started

This guide will help you get acquainted with the PSoC 4 M-Series Prototyping Kit:

- The [Software Installation chapter on page 13](#) describes the installation of the kit software. This includes installation of PSoC Creator IDE for development and debugging the applications, and PSoC Programmer for programming hex files.
- The [Kit Operation chapter on page 16](#) describes the major features of the PSoC 4 M-Series Prototyping Kit and functionalities such as programming, debugging, and the USB-UART and USB-I<sup>2</sup>C bridges.
- The [Hardware chapter on page 20](#) details the hardware content of the kit and the hardware operation.
- The [Code Examples chapter on page 33](#) describes code examples that will help you create your own PSoC 4 M-Series projects.
- The [Appendix on page 42](#) provides schematics, details about programming the kit using MiniProg3, and the bill of materials (BOM).

## 1.4 Additional Learning Resources

Cypress provides a wealth of information at [www.cypress.com](http://www.cypress.com) to help you to select the right PSoC device for your design, and to help you to quickly and effectively integrate the device into your design. For a comprehensive list of resources, see [KBA86521](#), [How to Design with PSoC 3](#), [PSoC 4](#), and [PSoC 5LP](#). The following is an abbreviated list for PSoC 4:

- Overview: [PSoC Portfolio](#) and [PSoC Roadmap](#)
- Product Selectors: [PSoC 1](#), [PSoC 3](#), [PSoC 4](#), or [PSoC 5LP](#). In addition, [PSoC Creator](#) includes a device selection tool.
- [Datasheets](#): Describe and provide electrical specifications for the PSoC 4 device family
- [CapSense Design Guide](#): Learn how to design capacitive touch-sensing applications with the PSoC 4 family of devices.
- [Application Notes and Code Examples](#): Cover a broad range of topics, from basic to advanced level. Many of the application notes include code examples. Visit the [PSoC 3/4/5 Code Examples](#) webpage for a list of all available PSoC Creator code examples. To access code examples from within PSoC Creator, see [PSoC Creator Code Examples on page 9](#).

- **Technical Reference Manuals (TRM):** Provide detailed descriptions of the architecture and registers in each PSoC 4 device family.
- **Development Kits:**
  - **CY8CKIT-040, CY8CKIT-042, and CY8CKIT-044** are easy-to-use and inexpensive development platforms. These kits include connectors for Arduino-compatible shields and Digilent Pmod peripheral modules.
  - **CY8CKIT-049 and CY8CKIT-043** are very low-cost prototyping platforms for sampling PSoC 4 devices.
  - The **MiniProg3** kit provides an interface for flash programming and debug.
- **Knowledge Base Articles (KBA):** Provide design and application tips from experts on using the device.
- **PSoC Creator Training:** Visit [www.cypress.com/go/creatorstart/creatortraining](http://www.cypress.com/go/creatorstart/creatortraining) for a comprehensive list of video trainings on PSoC Creator.
- **Learning From Peers:** Visit [www.cypress.com/forums](http://www.cypress.com/forums) to meet enthusiastic PSoC developers discussing the next generation embedded systems on Cypress Developer Community Forums.

## 1.5 Technical Support

If you have any questions, our technical support team is happy to assist you. You can create a support request on the [Cypress Technical Support](#) page.

If you are in the United States, you can talk to our technical support team by calling our toll-free number: +1-800-541-4736. Select option 2 at the prompt.

You can also use the following support resources if you need quick assistance.

- [Self-help](#)
- [Local Sales Office Locations](#)

## 1.6 Document Conventions

Table 1-1. Document Conventions for Guides

Convention	Usage
Courier New	Displays file locations, user entered text, and source code: C:\...\cd\icc\
<i>Italics</i>	Displays file names and reference documentation: Read about the <i>sourcefile.hex</i> file in the <i>PSoC Creator User Guide</i> .
<b>[Bracketed, Bold]</b>	Displays keyboard commands in procedures: <b>[Enter]</b> or <b>[Ctrl] [C]</b>
File > Open	Represents menu paths: File > Open > New Project
<b>Bold</b>	Displays commands, menu paths, and icon names in procedures: Click the <b>File</b> icon and then click <b>Open</b> .
Times New Roman	Displays an equation: $2 + 2 = 4$
Text in gray boxes	Describes Cautions or unique functionality of the product.

## 2. Software Installation



This chapter describes the steps to install the software tools and packages on a computer for using the PSoC 4 M-Series Prototyping Kit. This includes the IDE on which the projects will be built and used for programming.

### 2.1 Before You Begin

All Cypress software installations require administrator privileges, but these are not required to run the software after it is installed. Close any other Cypress software that is currently running before installing the kit software.

**Note:** By default, the kit contents are installed in `C:\Program Files\Cypress` for a 32-bit machine and `C:\Program Files(x86)\Cypress` for a 64-bit machine. This folder will contain the kit example project. To open this example, it is recommended to use the procedure described in the [Code Examples chapter on page 33](#). That procedure will create an editable copy of the example in a path that you chose so that the original installed example will not be modified.

### 2.2 Install Software

Follow these steps to install the PSoC 4 M-Series Prototyping kit software:

1. Download the kit software from [www.cypress.com/CY8CKIT-043](http://www.cypress.com/CY8CKIT-043). The kit software is available for download in three formats.
  - a. CY8CKIT-043 Kit Setup: This installation package contains the files related to the kit including PSoC Creator and PSoC Programmer. However, it does not include the Windows Installer or Microsoft .NET framework packages. If these packages are not on your computer, the installer directs you to download and install them from the Internet.
  - b. CY8CKIT-043 Kit Only: This executable file installs only the kit contents, which include a kit code example, hardware files, and user documents. This package can be used if all the software prerequisites (listed in step 5) are installed on your computer.
  - c. CY8CKIT-043 DVD ISO: This file is a complete package, stored in a DVD-ROM image format, that you can use to create a DVD or extract using an ISO extraction program such as WinRAR. The file can also be mounted similar to a virtual CD/DVD using virtual drive programs such as Virtual CloneDrive and MagicISO. This file includes all the required prerequisite software, utilities, drivers, hardware files, and user documents.
2. If you have downloaded the ISO file, mount it on a virtual drive. Extract the ISO contents if you do not have a virtual drive to mount. Double-click *cyautorun.exe* in the root directory of the extracted content or mounted ISO if "Autorun from CD/DVD" is not enabled on the computer. The installation window will appear automatically.

**Note:** If you are using the "Kit Setup" or "Kit Only" file, then go to step 4 for installation.

3. Click **Install CY8CKIT-043 Kit** to start the kit installation, as shown in [Figure 2-1](#).

Figure 2-1. Kit Installer Screen



4. Select the directory in which you want to install the PSoC 4 M-Series Prototyping kit-related files. Choose the directory and click **Next**.
5. When you click **Next**, the PSoC 4 M-Series Prototyping kit installer automatically installs the required software, if it is not present on your computer. Following are the required software:
  - a. PSoC Creator 3.2 or later: This software is also available at [www.cypress.com/psoccreator](http://www.cypress.com/psoccreator).
  - b. PSoC Programmer 3.23 or later: This is installed as part of PSoC Creator installation ([www.cypress.com/programmer](http://www.cypress.com/programmer)).
6. Choose the **Typical/Custom/Complete** installation type (select 'Typical' if you do not know which one to select) in the Product Installation Overview window, as shown in [Figure 2-2](#). Click **Next** after you select the installation type.

Figure 2-2. Product Installation Overview

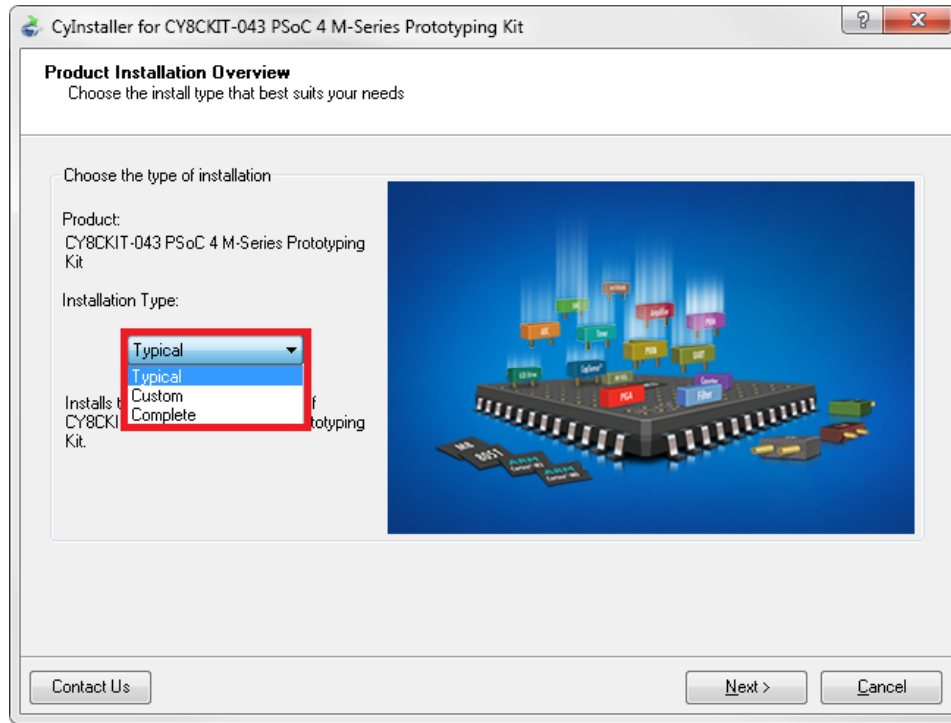

7. Read the License agreement and select **I accept the terms in the license agreement** to continue with the installation. Click **Next**.
8. When the installation begins, a list of packages appears on the installation page. A green check mark appears next to each package after successful installation.
9. Enter your contact information or select the check box **Continue Without Contact Information**. Click **Finish** to complete the kit installation.
10. After the installation is complete, the kit contents are available at the following location:  
`<Install_Directory>\CY8CKIT-043 PSoC 4 M-Series Prototyping Kit`

Default location:

Windows OS (64-bit):

`C:\Program Files (x86)\Cypress\CY8CKIT-043 PSoC 4 M-Series Prototyping Kit`

Windows OS (32-bit):

`C:\Program Files\Cypress\CY8CKIT-043 PSoC 4 M-Series Prototyping Kit`

**Note:** For Windows 7/8/8.1 users, the installed files and the folder are read-only. To use the installer code example, follow the steps outlined in the [Code Examples chapter on page 33](#).

## 2.3 Uninstall Software

The software can be uninstalled using one of the following methods:

1. Go to **Start > All Programs > Cypress > Cypress Update Manager** and select the **Uninstall** button next to the product that needs to be uninstalled.
2. Go to **Start > Control Panel > Programs and Features for Windows 7** or **Add/Remove Programs for Windows XP**; choose the product and select the **Uninstall/Change** button.

# 3. Kit Operation



This chapter introduces you to the features of the PSoC 4 M-Series Prototyping Kit. It describes the programming and debugging functionality, KitProg USB-UART and USB-I<sup>2</sup>C bridges, and the method to update the KitProg firmware.

## 3.1 Theory of Operation

Figure 3-1 shows the block diagram for the PSoC 4 M-Series Prototyping Kit.

Figure 3-1. Block Diagram of PSoC 4 M-Series Prototyping Kit

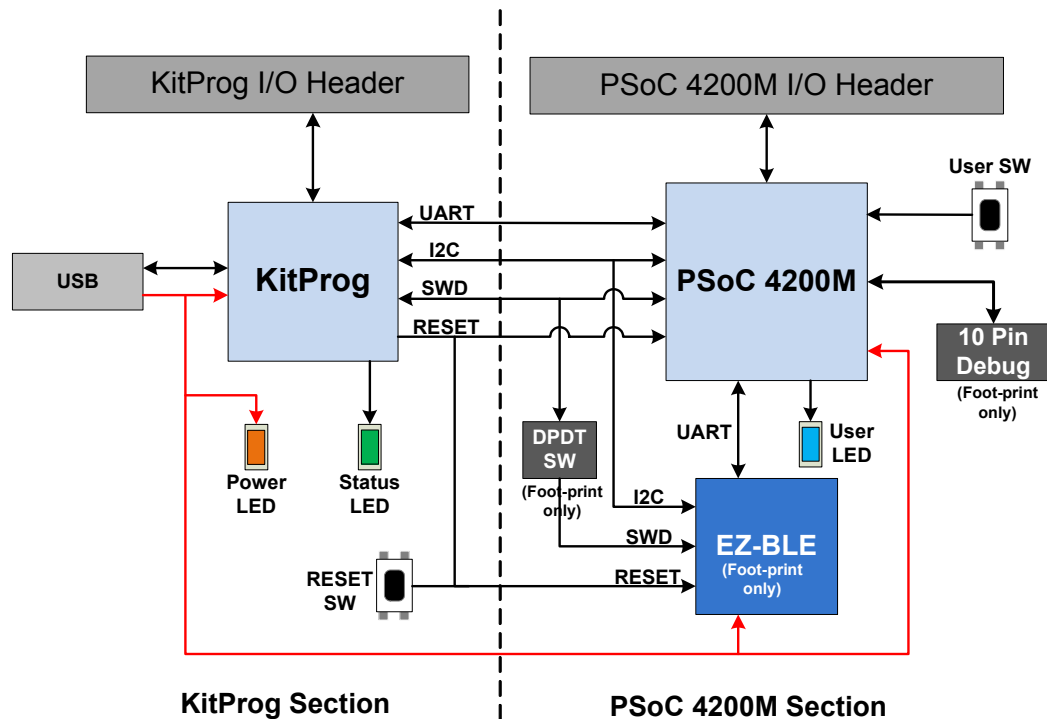

The PSoC 4 M-Series Prototyping Kit is simplistic in design and provides complete access to develop applications using the PSoC 4200M device family. This kit supports the following features:

- **KitProg:** It is an onboard programmer/debugger, which enables the user to program and debug the target PSoC 4200M device. It can also act as a USB-UART and USB-I<sup>2</sup>C bridge. When used as a standalone module, it can be used to program devices of PSoC 3, PSoC 4, or PSoC 5 families through the SWD interface. For more details on the KitProg functionality, refer to the [KitProg User Guide](#).
- **Expansion Headers:** The PSoC 4 M-Series Prototyping kit brings all I/Os of the target device to the two expansion headers, enabling the user to have maximum access to the capabilities of the PSoC 4200M device.

- **User LED:** The onboard LED can be used to display outputs from the PSoC 4200M device. This includes modulating the brightness of the LED to notify different states of the device.
- **Push Button (SW):** The push button can be used to provide input to the PSoC 4200M device.  
**Note:** The switch connects the PSoC 4200M pin to ground when pressed. Therefore, you need to configure the PSoC 4200M pin as resistive pull-up for detecting the switch press.
- **Reset Button:** This button is used for the following purposes:
  - **Reset the PSoC 4200M device:** When pressed, it connects the XRES line of the PSoC 4200M to ground and resets the PSoC 4200M device.
  - **Bootload the KitProg:** When pressed while connecting the kit's PCB USB connector to the USB port of the PC, the KitProg enters bootloader mode. For more details on the KitProg functionality, refer to the [KitProg User Guide](#).

**Note:** When the two boards are separated, the user can mount the SW2 button on the target board to reset the PSoC 4200M device using a switch.

- **EZ-BLE:** It is a fully integrated, 10×10×1.8 mm, fully certified, programmable BLE module designed for ease-of-use and reduced time-to-market. You can use the EZ-BLE module to add BLE capabilities to the board. The board only includes a footprint for the module. Refer to [Section 4.2.7 EZ-BLE PRoC Module on page 30](#) for details.
- **DPDT switch:** This switch is used to select the KitProg's SWD target (PSoC 4200M or EZ-BLE). By default, this switch is not populated on-board and the PSoC 4200M SWD lines are hard-wired to the KitProg's SWD programming lines.
- **10-pin program/debug header:** This header provides support for program/debug via the MiniProg3's 10-pin program/debug header. This header is not populated by default as the program/debug functionality is already provided by the on-board KitProg.

## 3.2 KitProg

The KitProg is a multi-functional system, which includes a programmer, debugger, USB-I<sup>2</sup>C bridge, and a USB-UART bridge. The Cypress PSoC 5LP device is used to implement the KitProg functionality. The KitProg is integrated in most PSoC development kits. For more details on the KitProg functionality, refer to the [KitProg User Guide](#) available on the kit web page or in the following location: <Install\_Directory>\CY8CKIT-043 PSoC 4 M-Series Prototyping Kit\  
<version>\Documentation\KitProg\_User\_Guide.pdf. This is also accessible from inside PSoC Creator by clicking on the kit name on the **Start** page (left pane) and then selecting **User Guide for KitProg** from the list of available documents (right pane).

## 3.3 Programming and Debugging the PSoC 4 Target Device

The target PSoC 4 device can be programmed and debugged using the built-in KitProg. Before programming the device, ensure that PSoC Creator and PSoC Programmer are installed on your computer. See [Install Software on page 13](#) for more information.

### 3.3.1 Programming Using PSoC Creator

1. Connect the kit to the computer through the PCB USB connector, J6, as shown in [Figure 3-2](#). The kit will enumerate as a composite device when you plug in the PSoC 4 M-Series Prototyping kit to your computer for the first time. The kit drivers should be automatically installed.

Figure 3-2. Connecting the PSoC 4 M-Series Prototyping Kit to a Computer

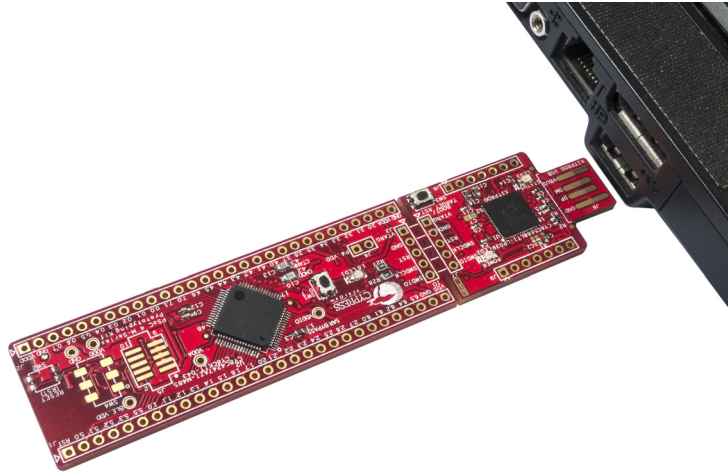

2. Open the desired project in PSoC Creator from **File > Open > Project/Workspace**. This provides the option to browse and open a previously saved project. If you want to open the example project provided with the kit, follow the instructions in the [Code Examples chapter on page 33](#).
3. Select **Build > Build Project** or press **[Shift] [F6]** to build the project as shown in [Figure 3-3](#).

Figure 3-3. Build an Example Project

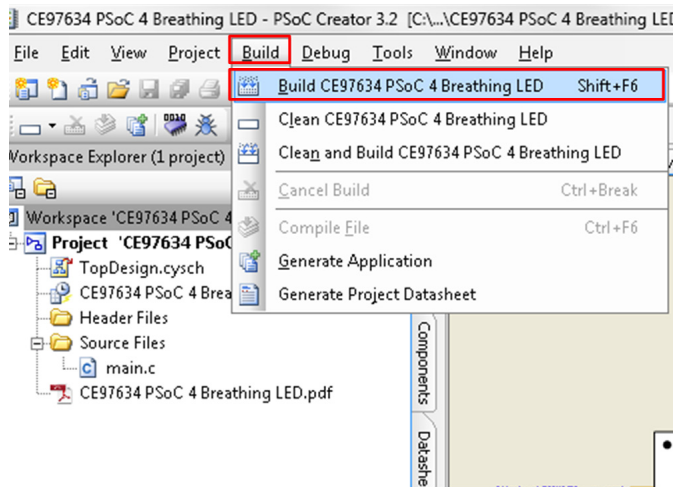

4. If there are no errors during build, program the firmware into the kit by choosing **Debug > Program** or press **[Ctrl] [F5]**, as shown in [Figure 3-4](#). This programs the target PSoC 4200M device on the PSoC 4 M-Series Prototyping Kit; the kit is now ready for use.

Figure 3-4. Programming Device From PSoC Creator

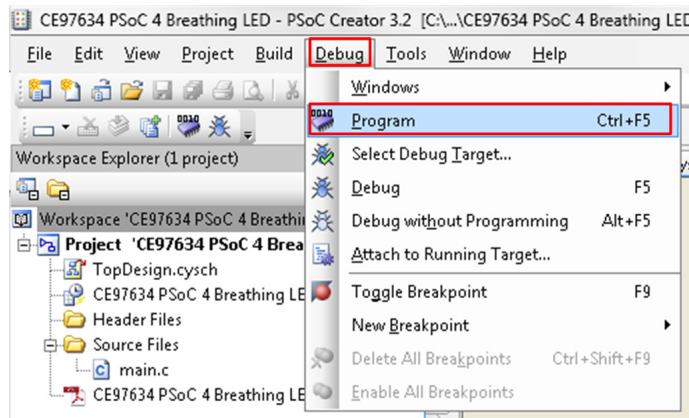

### 3.3.2 Debugging Using PSoC Creator

For debugging the project using PSoC Creator, follow steps 1 to 3 from [Programming Using PSoC Creator on page 17](#) followed by these steps:

1. Click the **Debug** icon  or press **[F5]**. Alternatively, you can choose **Debug > Debug**.
2. When PSoC Creator opens in Debug mode, use the buttons on the toolbar to debug your application.

For more details on using the debug features, refer to section 3.2 of the [KitProg User Guide](#).

### 3.3.3 Programming Using PSoC Programmer

PSoC Programmer (3.23 or later) can be used to program existing *.hex* files into the PSoC 4 M-Series Prototyping Kit. Refer to section 3.3 of the [KitProg User Guide](#) for a detailed explanation on how to program using PSoC Programmer.

## 3.4 USB-UART Bridge

The KitProg can act as a USB-UART bridge. The UART lines between the KitProg and the target are hard-wired on the board, through the snappable area, with UART\_RX assigned to P7[1] and UART\_TX assigned to P7[0] on PSoC 4200M. For more details on the KitProg USB-UART functionality, refer to section 5 of the [KitProg User Guide](#).

## 3.5 USB-I<sup>2</sup>C Bridge

The KitProg can function as a USB-I<sup>2</sup>C bridge and communicate with the Bridge Control Panel (BCP) software utility. The I<sup>2</sup>C lines on the PSoC 4200M device are P4[1] (SDA) and P4[0] (SCL), which are hardwired on the board to the I<sup>2</sup>C lines of the KitProg. The USB-I<sup>2</sup>C supports I<sup>2</sup>C speeds of 50 kHz, 100 kHz, 400 kHz, and 1 MHz. For more details on the KitProg USB-I<sup>2</sup>C functionality, refer to section 6 of the [KitProg User Guide](#).

## 3.6 Updating the KitProg Firmware

The KitProg firmware normally does not require any update. You can use PSoC Programmer to update the KitProg firmware. Refer to section 3.5 of the [KitProg User Guide](#) for more details.

# 4. Hardware



## 4.1 Board Details

The PSoC 4 M-Series Prototyping Kit consists of the following blocks:

- PSoC 4200M device U2 (CY8C4247AZI-M485)
- PSoC 4200M headers J1 and J2
- PSoC 4200M 10-pin program/debug header J5 (footprint only)
- KitProg (PSoC 5LP) device U1 (CY8C5868LTI-LP039)
- KitProg headers J8 and J9
- SWD connection J3 and J7
- USB finger connector J6
- EZ-BLE™ PSoC™ module U4 (footprint only)
- One DPDT switch SW4 to select the SWD target device (footprint only)
- One blue LED LED1 (User)
- One amber LED LED2 (Power)
- One green LED LED3 (Status)
- User push button SW1
- Reset buttons SW2 (footprint only) and SW3
- External reference capacitor C3 (SARADC bypass)
- CapSense capacitors (CMOD C10 and CTANK C13)
- Current measurement jumper J4 (footprint only)
- Perforated 'snappable' board design

Figure 4-1. PSoC 4 M-Series Prototyping Kit Pin Details

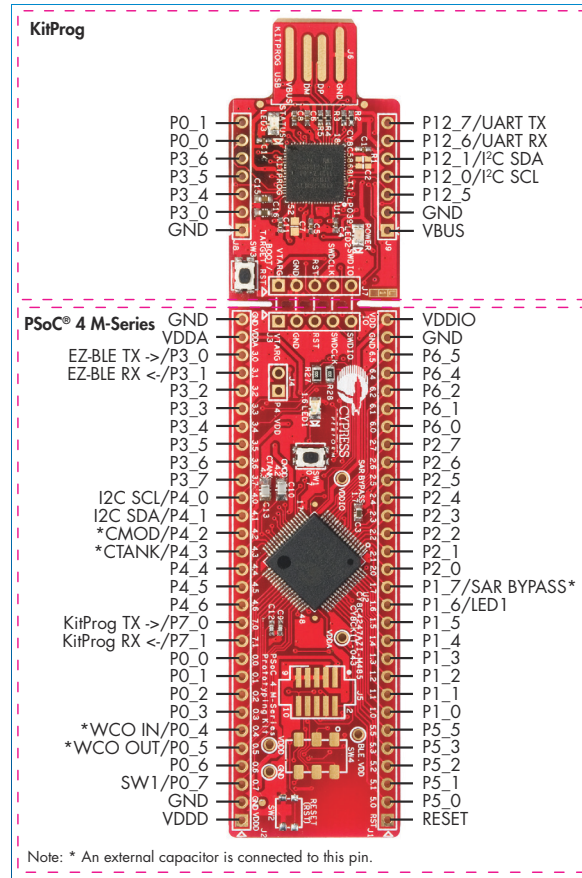



### 4.2.2 KitProg Board

PSoC 5LP on the KitProg board is used to program and debug the target PSoC 4 device. The KitProg PSoC 5LP connects to the USB port of the computer through the PCB USB connector and to the SWD interface of the target PSoC 4 device. See the [KitProg User Guide](#) for additional details and functions provided by the KitProg.

Figure 4-3. Schematic of PSoC 5LP (KitProg)

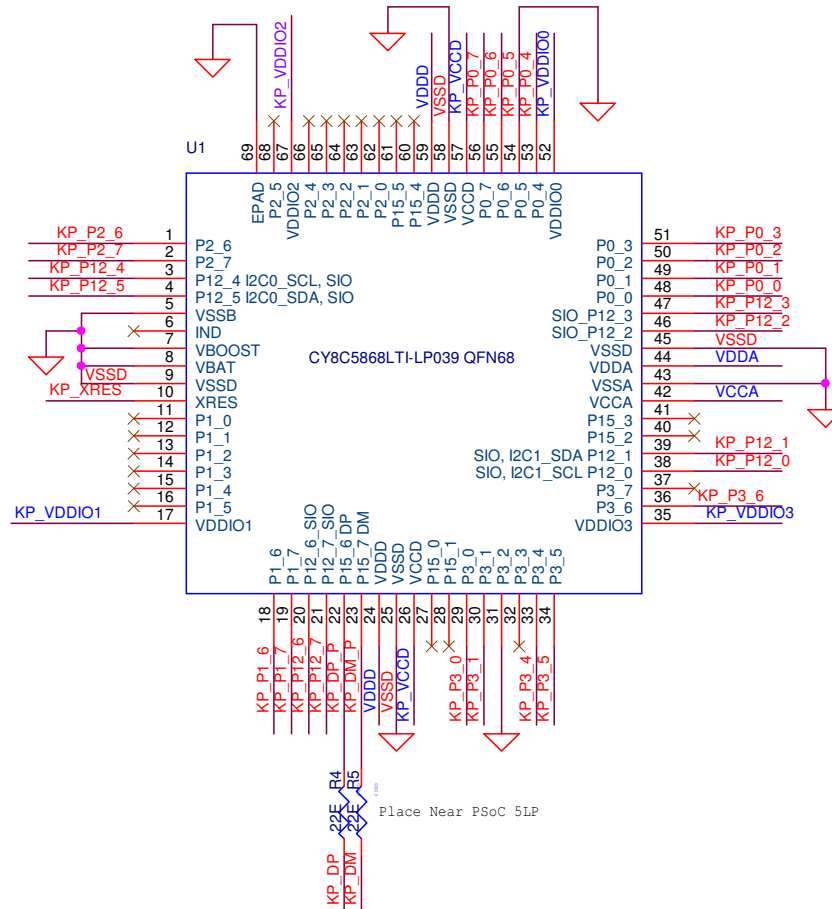

### 4.2.3 Power Supply System

The power supply system on this board is dependent on the power source. For most applications, you can use the 5-V supply from the USB connection to power the system. You can also connect an external power supply to the board for low-voltage applications. The kit supports the following connections:

- 5 V from the KitProg USB (J6)
- 3.3 V to 5.5 V from a regulated supply connected to VDD (this will not power the KitProg section of the board)

**Note:** To use an external power supply, while the KitProg is connected to the PCB USB, remove the D1 diode from the board. This ensures that VTARG supply from the KitProg is not supplied to the target device. The KitProg measures the target voltage and adjusts the logic levels on the programming pins accordingly.

**Note that this prototyping kit does not have any onboard ESD protection circuitry. Therefore, the power source for the PSoC 4 M-Series Prototyping Kit must be of a high quality to ensure that the board is protected from any over-current conditions and swapped-power connections.**

#### 4.2.3.1 Measure PSoC 4 Current Consumption

You can measure current consumption of the PSoC 4200M device by using one of these methods:

Method 1:

1. Separate the KitProg board by 'snapping' the perforated edge between the two boards.
2. Power the remaining prototyping board via any of the VDD or VTARG terminals.
3. Place an ammeter in series with the VDD or VTARG connection to measure current consumption.

Method 2:

1. Remove the resistor R22 and install a 2-pin jumper in the supplied holes of J4.
2. Connect an ammeter across the 2-pin jumper to measure the current to the PSoC 4200M device.

This method can be used either with USB power or with power supplied to one of the VTARG pins but NOT when supplying power to one of the VDD pins.

### 4.2.4 Board Separation (Snapping)

The PSoC 4 M-Series Prototyping Kit consists of both a PSoC 4200M and a KitProg board. To separate the two boards for evaluation or development, break the two boards apart at the built-in perforated edge.

The easiest method of separating the two boards is to place the kit on the edge of a table, where the edge of the table is directly below the perforated edge and the smaller KitProg board is off the table edge. Press gently on the KitProg board and snap the two boards apart. If any material is removed from the edge of the boards, use shears to clean up the edge of the kit. Note that once the boards are separated, direct UART and I<sup>2</sup>C connections between the PSoC 4200M device and KitProg are lost. This is because the traces connecting the UART and I<sup>2</sup>C lines are cut off during the separation. However, you can access the KitProg's UART and I<sup>2</sup>C lines through headers J8 and J9.

Figure 4-4. PSoC 4 M-Series Prototyping Kit Broken into Two Parts

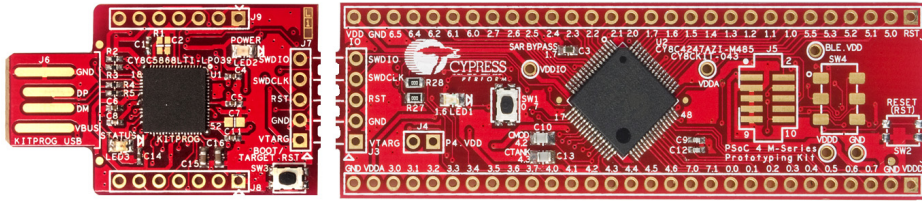

## 4.2.5 Header Connections

The PSoC 4 M-Series Prototyping Kit supports a number of unpopulated headers on both the KitProg and the target PSoC 4 boards.

### 4.2.5.1 Functionality of J1 and J2 Headers (Target Board)

The target board contains two, dual-inline, headers (J1 and J2). Both are 1×29 pin headers and include all of the I/Os available on the PSoC 4200M device. These headers support all of the available ports, GND, VDD, and connections to passive elements and user-input devices. The J1 and J2 headers support 100-mil spacing, so you can solder connectors to connect the target board to any development breadboard.

Figure 4-5. J1 and J2 Headers

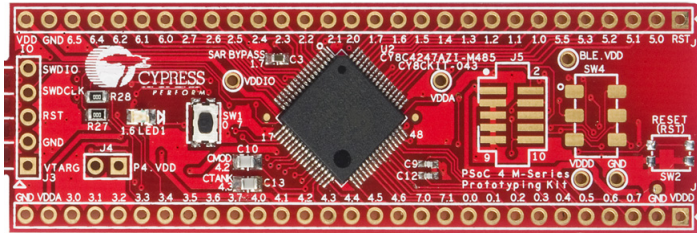

Table 4-1. J1 Header Pin Details

PSoC 4 M-Series Prototyping Kit GPIO		
Pin	Signal	Description
J1_01	/XRES	GPIO
J1_02	P5[0]	GPIO
J1_03	P5[1]	GPIO
J1_04	P5[2]	GPIO
J1_05	P5[3]	GPIO
J1_06	P5[5]	GPIO
J1_07	P1[0]	GPIO
J1_08	P1[1]	GPIO
J1_09	P1[2]	GPIO
J1_10	P1[3]	GPIO
J1_11	P1[4]	GPIO
J1_12	P1[5]	GPIO
J1_13	P1[6]	GPIO/LED (LED1)
J1_14	P1[7]	GPIO/SAR BYPASS
J1_15	P2[0]	GPIO
J1_16	P2[1]	GPIO
J1_17	P2[2]	GPIO
J1_18	P2[3]	GPIO
J1_19	P2[4]	GPIO
J1_20	P2[5]	GPIO
J1_21	P2[6]	GPIO
J1_22	P2[7]	GPIO
J1_23	P6[0]	GPIO
J1_24	P6[1]	GPIO
J1_25	P6[2]	GPIO
J1_26	P6[4]	GPIO
J1_27	P6[5]	GPIO
J1_28	GND	Ground
J1_29	VDDIO	Power

Table 4-2. J2 Header Pin Details

PSoC 4 M-Series Prototyping Kit GPIO		
Pin	Signal	Description
J2_01	VDDD	Power
J2_02	GND	Ground
J2_03	P0[7]	GPIO/SW (SW1)
J2_04	P0[6]	GPIO
J2_05	P0[5]	GPIO/XTAL_OUT
J2_06	P0[4]	GPIO/XTAL_IN
J2_07	P0[3]	GPIO
J2_08	P0[2]	GPIO
J2_09	P0[1]	GPIO
J2_10	P0[0]	GPIO
J2_11	P7[1]	GPIO/->UART_RX
J2_12	P7[0]	GPIO/<-UART_TX
J2_13	P4[6]	GPIO
J2_14	P4[5]	GPIO
J2_15	P4[4]	GPIO
J2_16	P4[3]	GPIO/CTANK
J2_17	P4[2]	GPIO/CMOD
J2_18	P4[1]	GPIO/I2C_SDA
J2_19	P4[0]	GPIO/I2C_SCL
J2_20	P3[7]	GPIO
J2_21	P3[6]	GPIO
J2_22	P3[5]	GPIO
J2_23	P3[4]	GPIO
J2_24	P3[3]	GPIO/SWDCLK
J2_25	P3[2]	GPIO/SWDIO
J2_26	P3[1]	GPIO/->BLE_RX
J2_27	P3[0]	GPIO/<-BLE_TX
J2_28	VDDA	Power
J2_29	GND	Ground

#### 4.2.5.2 Functionality of J7 and J3 Headers (PSoC 4200M to KitProg)

The KitProg and target boards each contain a 1×5-pin header. These headers provide a physical connection between the two devices. Specifically, the connection includes the SWD interface, required to program/debug the target PSoC 4200M device, power, ground, and reset.

Figure 4-6. J7 and J3 Headers

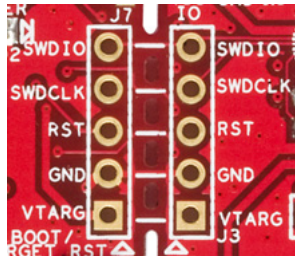

Table 4-3. Pin Details of J7 Header

PSoC 5LP KitProg Header (J7)		
Pin	Signal	Description
J7_01	VTARG	Power
J7_02	GND	Ground
J7_03	P12.4	PROG_XRES
J7_04	P12.3	PROG_SWDCLK
J7_05	P12.2	PROG_SWDIO

Table 4-4. Pin Details of J3 Header

PSoC 4 M-Series Prototyping Kit GPIO (J3)		
Pin	Signal	Description
J3_01	VTARG	Power
J3_02	GND	Ground
J3_03	XRES	XRES
J3_04	P3.3	SWDCLK
J3_05	P3.2	SWDIO

When the boards are separated, the KitProg board can be used to program any other PSoc 3, PSoc 4, or PSoc 5LP device family member via J7.

#### 4.2.5.3 Functionality of J8 and J9 Headers (KitProg)

The KitProg board contains two, dual-inline, headers (J8 and J9). Both are 1×7-pin-headers, used to provide access to several pins of the PSoc 5LP to support advanced features such as a low-speed oscilloscope and a low-speed digital logic analyzer. These headers also contain the KitProg bridge pins (USB to UART and USB to I<sup>2</sup>C) that can be used when the two boards are separated.

The J8 and J9 headers support 100-mil spacing, so you can solder connectors to connect the KitProg board to any development breadboard.

Figure 4-7. J8 and J9 Headers

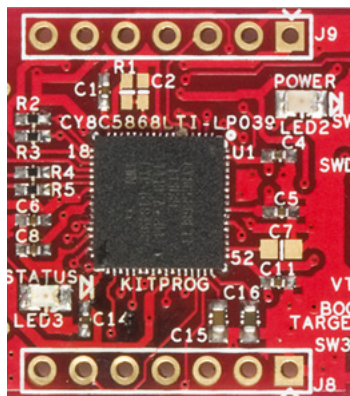

Table 4-5. Pin Details of J9

PSoC 5LP to KitProg Header (J9)		
Pin	Signal	Description
J9_01	VBUS	Power
J9_02	GND	Ground
J9_03	P12.5	GPIO
J9_04	P12.0	GPIO/I2C_SCL
J9_05	P12.1	GPIO/I2C_SDA
J9_06	P12.6	GPIO/UART_RX
J9_07	P12.7	GPIO/UART_TX

Table 4-6. Pin Details of J8

PSoC 5LP to KitProg Header (J8)		
Pin	Signal	Description
J8_01	GND	Ground
J8_02	P3.0	GPIO
J8_03	P3.4	GPIO
J8_04	P3.5	GPIO
J8_05	P3.6	GPIO
J8_06	P0.0	GPIO
J8_07	P0.1	GPIO

## 4.2.6 User and Passive Inputs

### 4.2.6.1 Push Button

The target PSoC 4 board contains a single push button connected to the P0[7] pin on the PSoC 4200M device. This button can be used for general user inputs or to control different states in an application.

Figure 4-8. Push Button on the Board

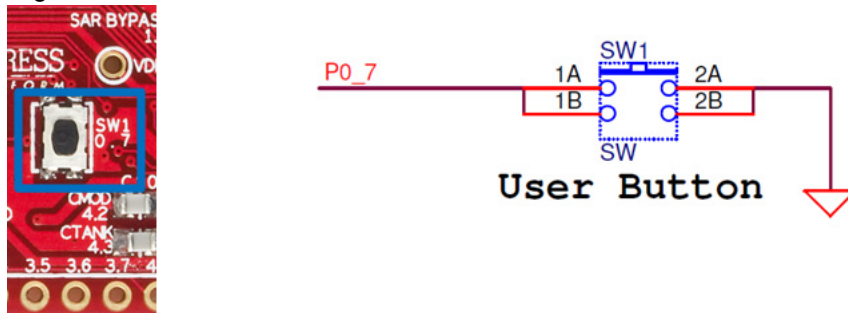

### 4.2.6.2 Reset/Boot Button

The KitProg board contains a push button connected to the XRES pins on the target PSoC 4200M and EZ-BLE devices. The button is also connected to P12\_4 of the KitProg device. This button serves two functions:

- Reset the PSoC 4200M and EZ-BLE devices: When this button is pressed, the XRES lines of the PSoC 4200M and EZ-BLE are connected to ground, which, in turn, resets the devices.
- Bootload the KitProg: When this button is held down while plugging the KitProg into the USB port of the PC, the KitProg enters the bootloader mode. In this mode, bootloadable applications can be downloaded on the KitProg device. The bootloader mode is indicated by the green LED (LED3) flashing.

Figure 4-9. Reset/Boot Button

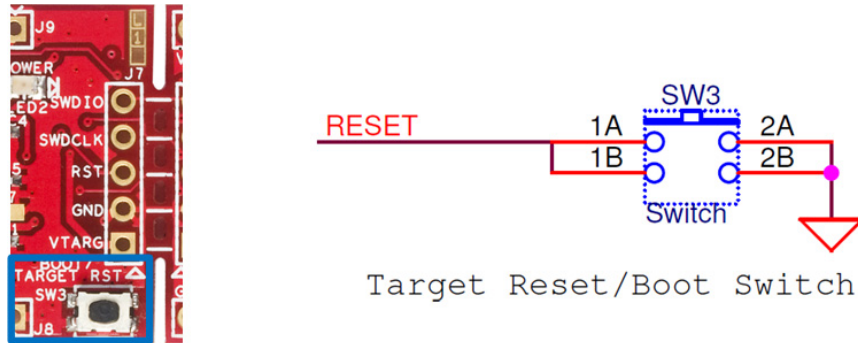

**Reset Button**

The target board provides a footprint for a surface-mount switch, which can be used to reset the PSoC 4200M and EZ-BLE devices when the two boards are separated.

Figure 4-10. Reset (RST) Button

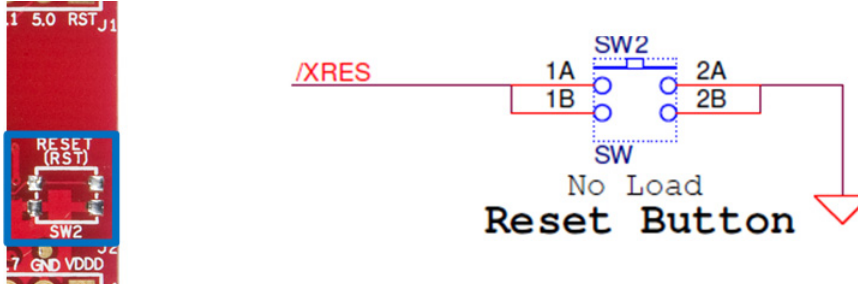

4.2.6.3 LEDs

The PSoC 4 M-Series Prototyping kit contains three LEDs:

- The amber LED: Indicates that the board is powered from the PCB USB connector. This LED will not light when the board is powered from VDD or VTARG directly.
- The green LED: Indicates the KitProg status, connected to P3[1] of the KitProg PSoC 5LP device. For more details on the KitProg status LED, refer to the [KitProg User Guide](#).
- The blue LED: This is the user LED, connected to P1[6] of the target PSoC 4200M device.

Figure 4-11. Power LED

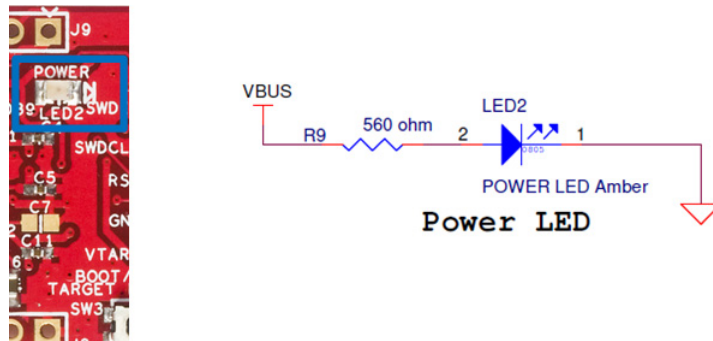

Figure 4-12. Status LED

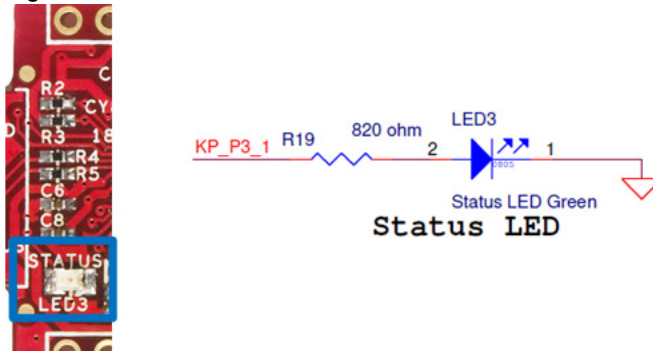
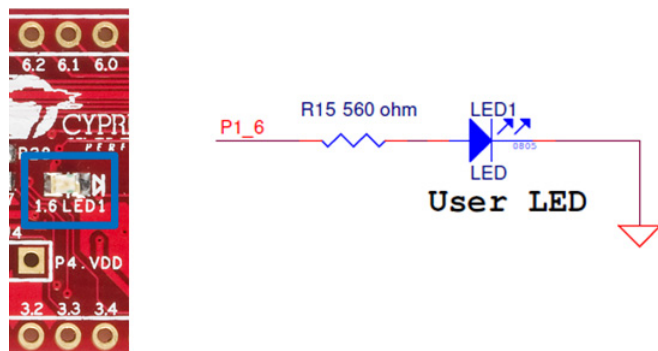

Figure 4-13. User LED (Blue)



#### 4.2.6.4 System Capacitors

The PSoC 4 M-Series Prototyping Kit has five capacitors in addition to power supply decoupling capacitors:

- A SAR ADC bypass capacitor (C3): Required for proper ADC sampling at higher frequencies.
- Two CapSense capacitors (CMOD and CTANK): Required for proper CapSense functionality.
- Two biasing capacitors (C9 and C12): Required to interface an external 32-kHz crystal oscillator.

**Note:** The crystal oscillator is not placed on the board; it can be soldered on pins P0[5] and P0[4].

Figure 4-14. System Capacitors Circuit Diagram

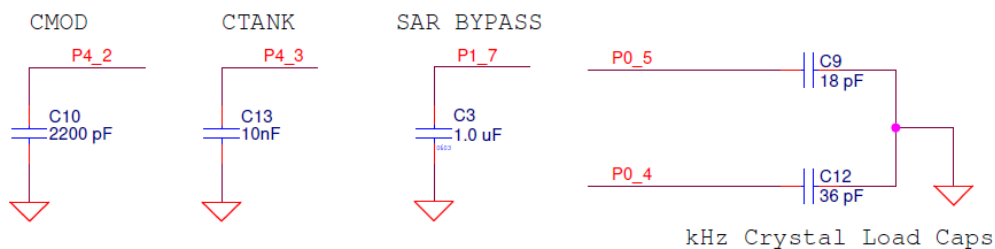

#### 4.2.7 EZ-BLE PSoC Module

The board includes a footprint for mounting an [EZ-BLE PSoC Module](#). The EZ-BLE PSoC Module is a fully integrated, 10×10×1.8 mm, fully certified, programmable module designed for ease-of-use and reduced time-to-market. It contains Cypress’s PSoC BLE chip, two crystals, chip antenna, shield, and passive components. Refer to [AN96841 - Getting Started With EZ-BLE PSoC Module](#) for more details. Visit [www.cypress.com/ez-bleprocmodule/](http://www.cypress.com/ez-bleprocmodule/) to buy the EZ-BLE module.

Figure 4-15. EZ-BLE Connections

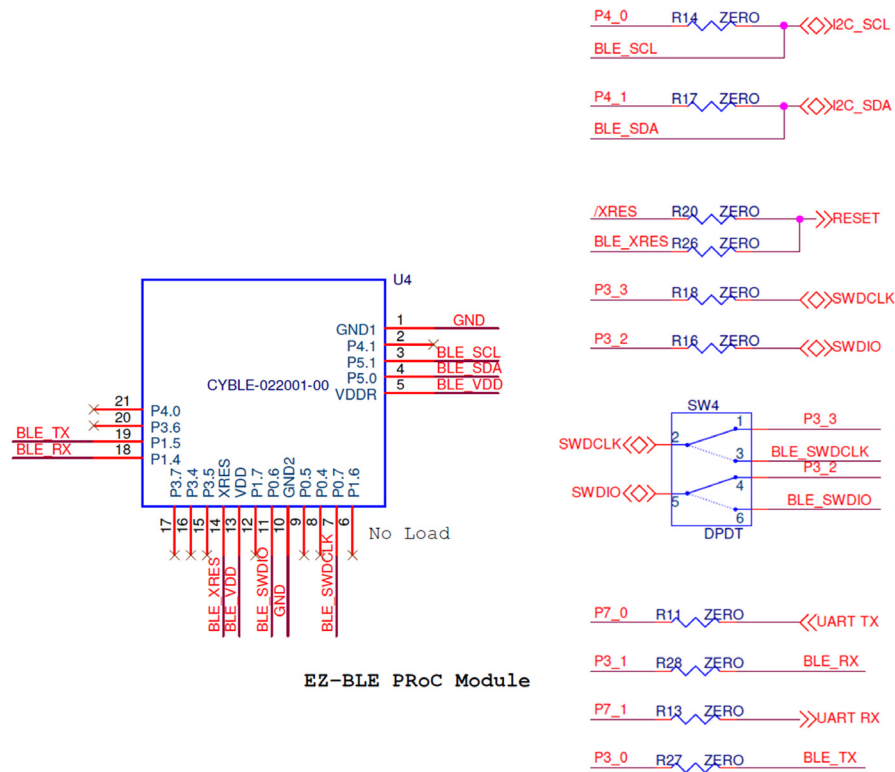

The EZ-BLE module includes the following connections to the PSoC 4200M and KitProg:

- UART connections to PSoC 4200M through zero-ohm resistors R28 and R27 (see [Figure 4-16](#) and [Table 4-7](#)).
- I<sup>2</sup>C connections to KitProg and PSoC 4200M. See [Table 4-7](#) for details.
- SWD connections to KitProg through the DPDT switch SW4. The SWD connections are shared between the PSoC 4200M and EZ-BLE devices. By default, SW4 is not populated and the KitProg SWD connections are hardwired to PSoC 4200M through zero-ohm resistors, R18 and R16.

Table 4-7. EZ-BLE Connections

EZ-BLE Connections			
EZ-BLE	PSoC 4	KitProg	Description
BLE_TX, P1.5	P3.0	–	GPIO/UART_TX
BLE_RX, P1.4	P3.1	–	GPIO/UART_RX
BLE_SDA, P5.0	P4.1	I2C_SDA, P12.1	GPIO/I2C_SDA
BLE_SCL, P5.1	P4.0	I2C_SCL, P12.0	GPIO/I2C_SCL
BLE_SWDIO, P0.6	–	SWDIO, P12.2	SWD I/O
BLE_SWDCLK, P0.7	–	SWDCLK, P12.3	SWD clock

To program the EZ-BLE module using Kitprog, follow these instructions:

1. Populate the DPDT switch, SW4. Refer to row no. 36 in [Appendix A.3 Bill of Materials on page 45](#) for the part number of the switch to be used.
2. Populate the EZ-BLE PROC module, U4 (footprint on the bottom of the board)

3. Remove the zero-ohms resistors R18 and R16
4. Move the DPDT switch SW4 to position A as shown in [Figure 4-16](#) to program PSoC 4200M and to position B as shown in [Figure 4-17](#) to program the EZ-BLE module

Figure 4-16. SW4 Position for Programming PSoC 4200M



Figure 4-17. SW4 Position for Programming EZ-BLE



# 5. Code Examples



This chapter explains the code example provided along with the PSoC 4 M-Series Prototyping Kit as well as how to use the built-in PSoC Creator examples with the kit. To access the code example, download and install the CY8CKIT-043 PSoC 4 M-Series Prototyping Kit setup file from [www.cypress.com/CY8CKIT-043](http://www.cypress.com/CY8CKIT-043). After installation, the code example will be available in the `Firmware` folder in the installation location.

For more code examples, visit the [PSoC 3, PSoC 4, and PSoC 5 code examples page](#), which lists all PSoC Creator code examples available across application notes, kits, and PSoC Creator.

## 5.1 Using the Kit Code Example

Follow these steps to open and use the code example provided with the kit.

1. Launch PSoC Creator from **Start > All Programs > Cypress > PSoC Creator<version> > PSoC Creator <version>**.
2. On the **Start Page**, click **CY8CKIT-043** under **Examples and Kits > Kits**. The code example **CE97634 PSoC 4 Breathing LED**, shipped with the kit, appears (see [Figure 5-1](#)).
3. Click on the example project and save it at a desired location.

Figure 5-1. Open Example Project from PSoC Creator

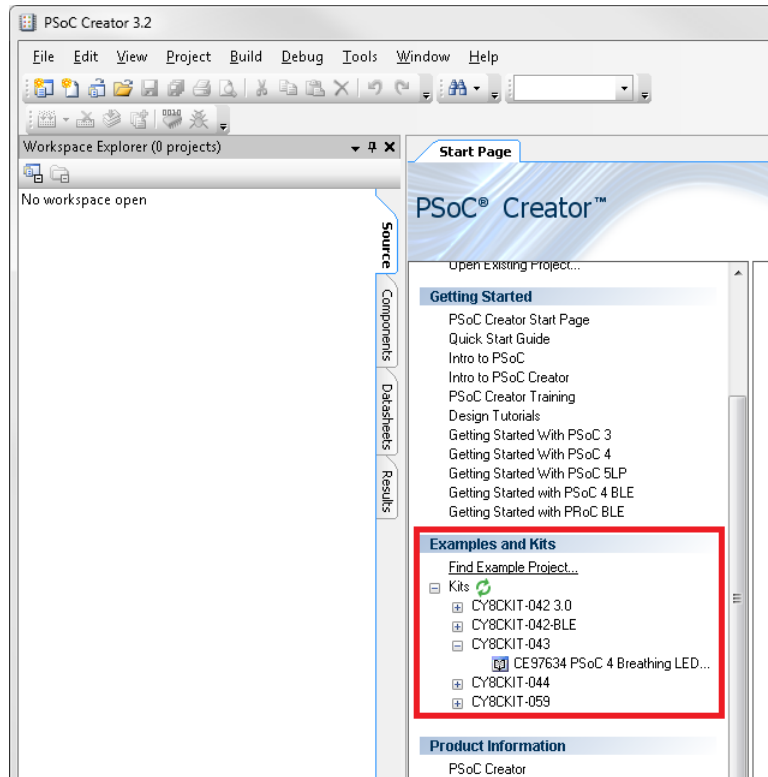

4. Build the example project by choosing **Build > Build <Project Name>**, as shown in Figure 5-2. A .hex file is generated after a successful build process.

Figure 5-2. Build Example Project from PSoC Creator

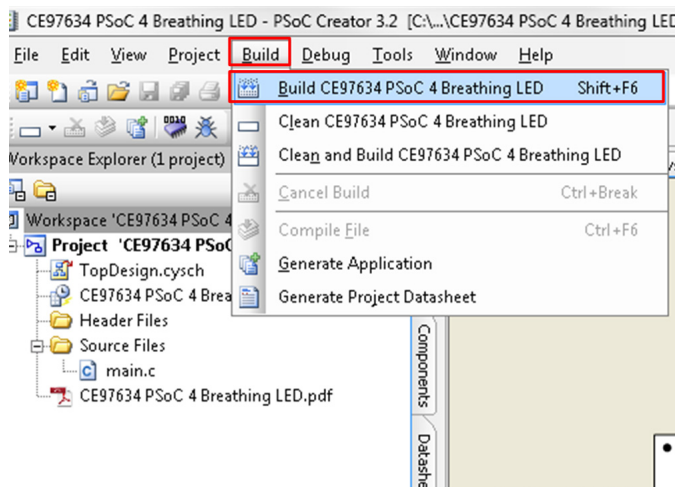

5. Connect the PSoC 4 M-Series Prototyping kit to the PC using the KitProg PCB USB port, J6, as described in [Programming Using PSoC Creator chapter on page 17](#) to program the kit with this code example. If this is the first time the kit is connected, wait for drivers to be installed.
6. Choose **Debug > Program** in PSoC Creator as shown in Figure 5-3.

Figure 5-3. Program Device in PSoC Creator

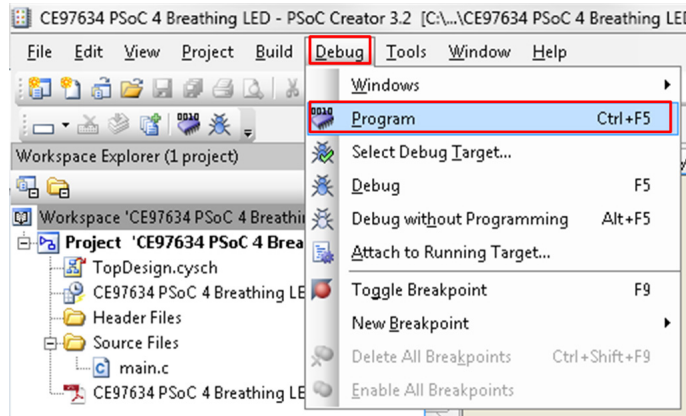

7. PSoC Creator opens the programming window if the device is not yet acquired. Select KitProg and click the **Port Acquire** button, as shown in Figure 5-4.

Figure 5-4. Port Acquire

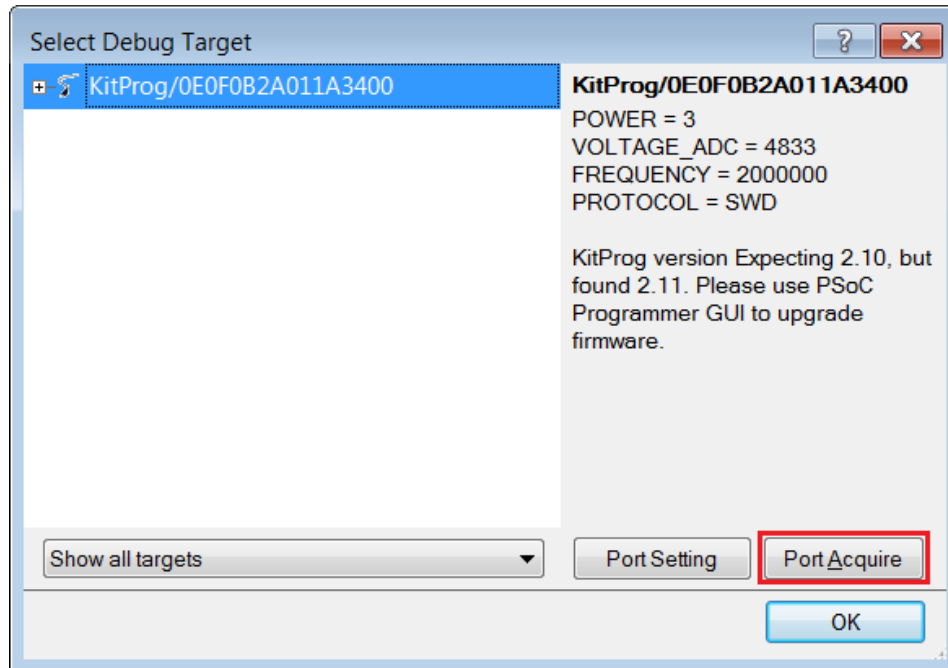

8. After the device is acquired, it is shown in a tree structure below the KitProg. Click the **Connect** button and then **OK** to exit the window and start programming, as shown in Figure 5-5.

Figure 5-5. Connect Device From PSoC Creator and Program

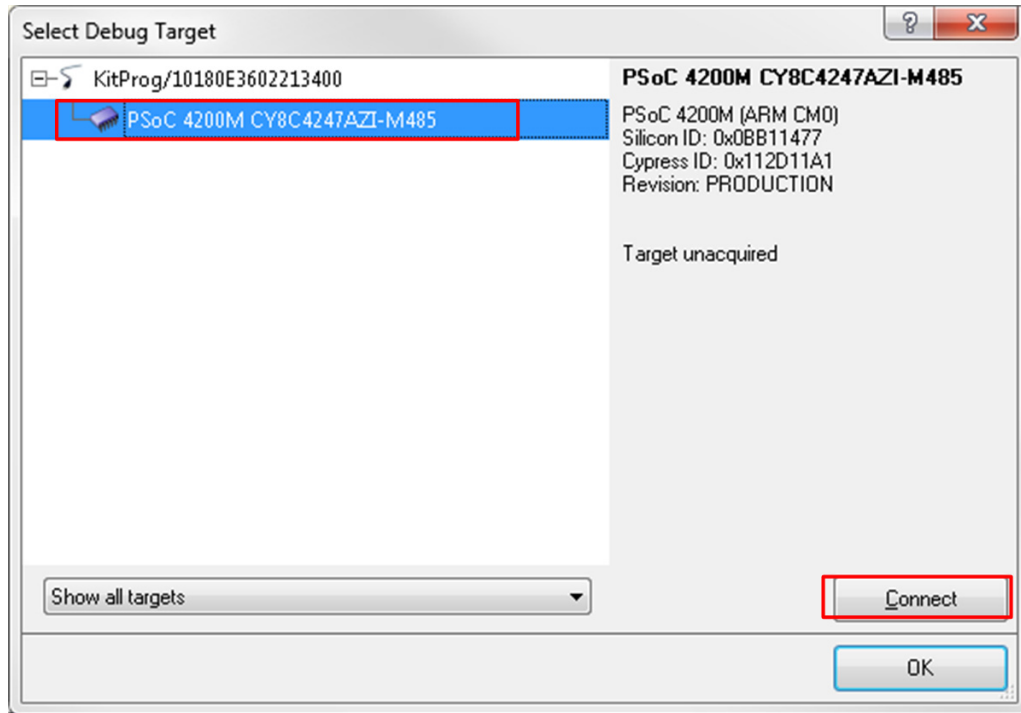

9. Once programming is successful, the blue LED (LED1) on the board should start displaying the breathing effect at approximately 1-Hz rate. From the Workspace Explorer in PSoC Creator, open the *CE97634 PSoC 4 Breathing LED.pdf* as shown in Figure 5-6. This document provides details of the code example.

Figure 5-6. Project Datasheet - CE97634 PSoC 4 Breathing LED.pdf

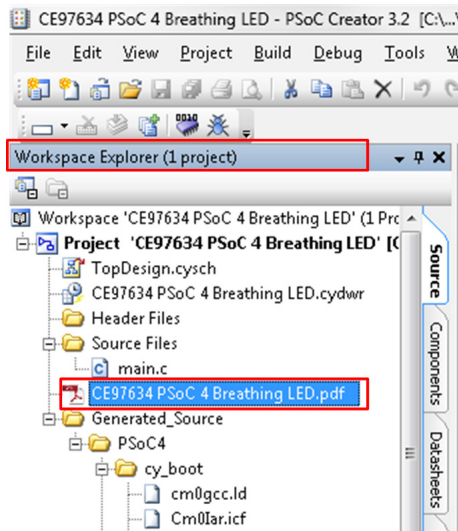

## 5.2 Using Built-in PSoC Creator Code Examples with the Kit

Follow these steps to open and use the built-in PSoC Creator examples.

1. Launch PSoC Creator from **Start > All Programs > Cypress > PSoC Creator<version> > PSoC Creator <version>**.
2. On the Start Page, click **Find Example Project...** under **Examples and Kits**, as shown in [Figure 5-7](#).

Figure 5-7. PSoC Creator Find Example Project...

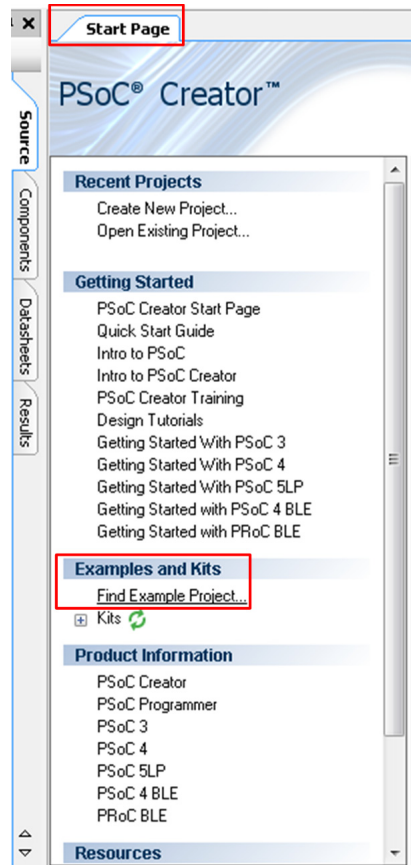

3. In the Find Example Project window, set the **Device Family** to **PSoC 4200M** as shown in [Figure 5-8](#).

Figure 5-8. Selecting PSoC 4200M Device Family in Find Examples Window

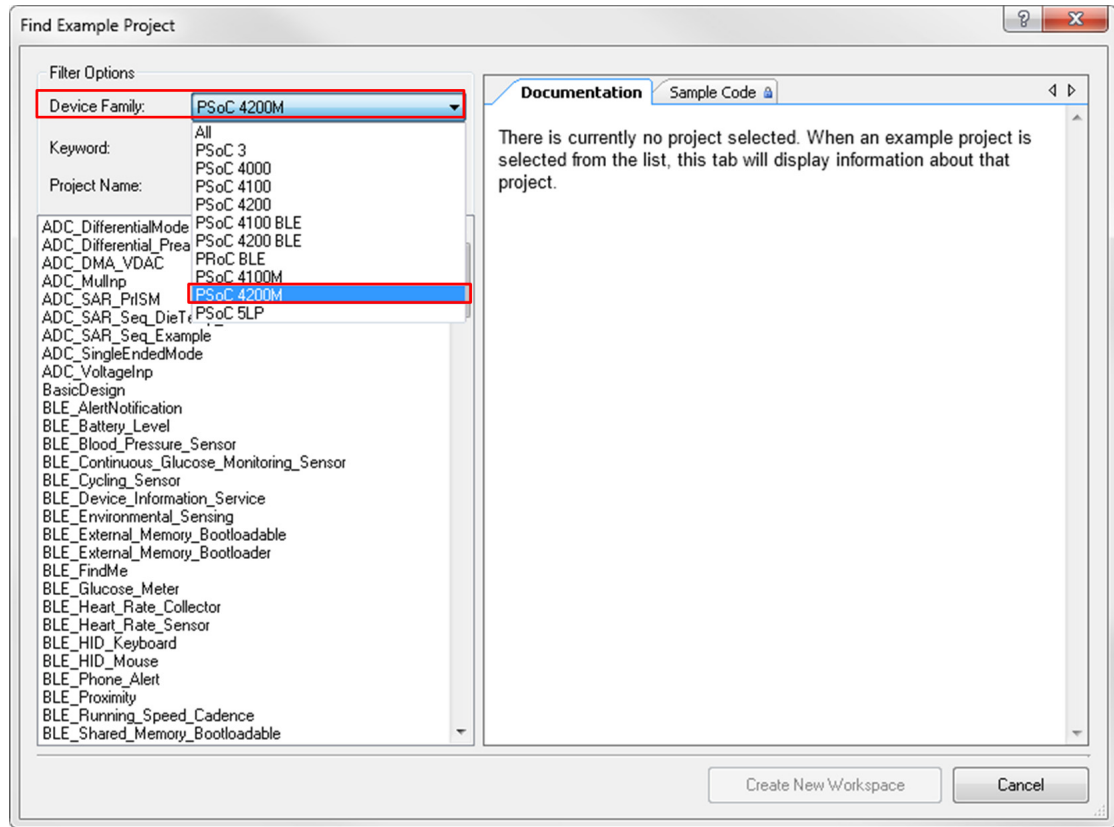

4. You can use any project that appears in the list with the kit. As an example, we will select the **ADC\_SAR\_Seq\_DieTemp\_PSoC4** project and see how to use it with CY8CKIT-043.
5. Select the **ADC\_SAR\_Seq\_DieTemp\_PSoC4** project and click the **Create New Workspace** button. Save the workspace to a desired location. See [Figure 5-9](#).

Figure 5-9. ADC\_SAR\_Seq\_DieTemp\_PSoC4 Code Example

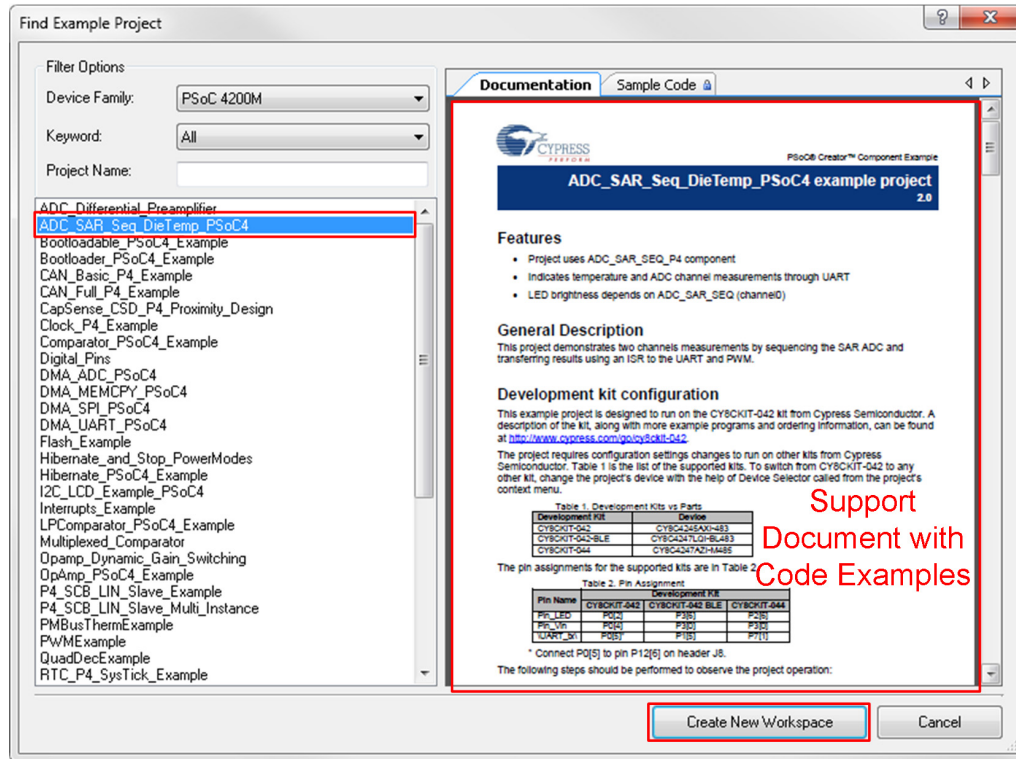

- This example project measures an input voltage in the range 0 to 1.024 V on a pin and sends the measured voltage and device die temperature over UART. In addition, the project controls the brightness of an LED using a PWM based on the value measured by the ADC. Map the UART and LED pins as shown in Figure 5-10 to use the example with the kit. The pin used to measure an analog input voltage using the ADC can be mapped to any pin.

Figure 5-10. cydwr Settings for CY8CKIT-043

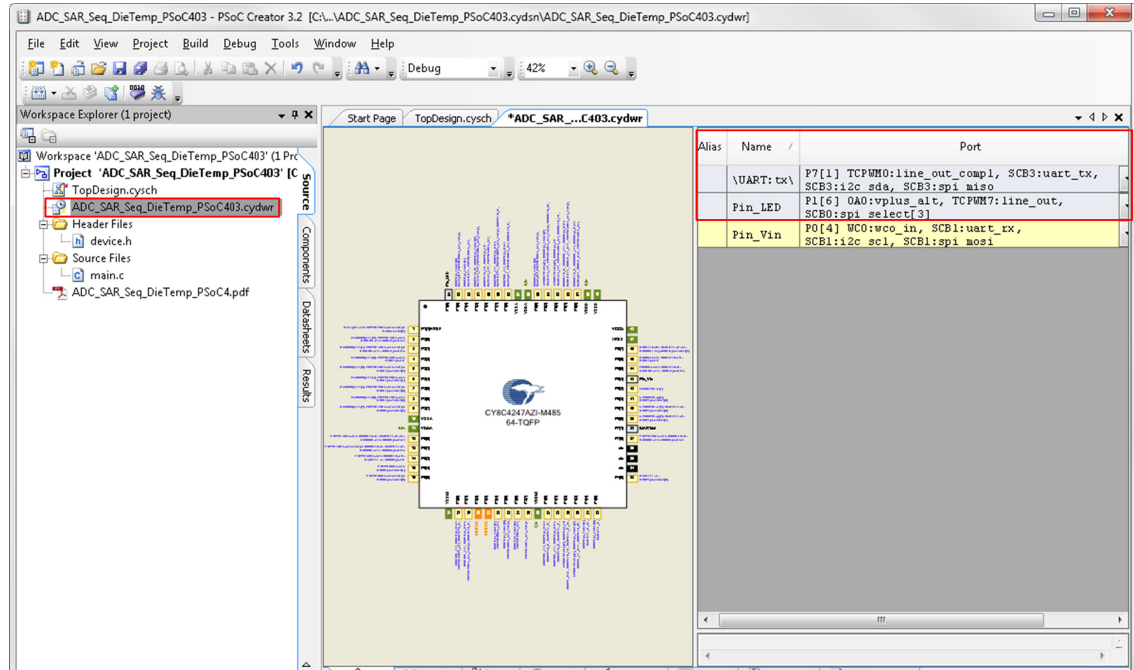

- For CY8CKIT-043, make sure the device used is CY8C4247AZI-M485 as shown in Figure 5-11. Build the project and program the kit as explained in Using the Kit Code Example on page 33.

Figure 5-11. Device Selector Settings

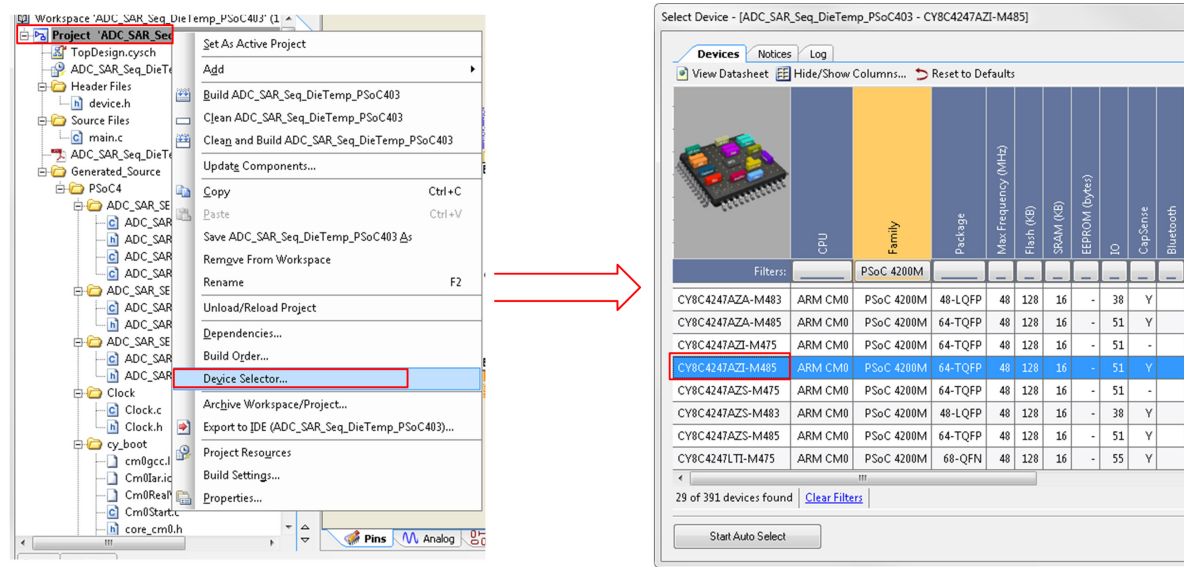

- Open **ADC\_SAR\_Seq\_DieTemp\_PSoC4.pdf** from the Workspace Explorer to learn more about the example project and its configuration. See Figure 5-12.

Figure 5-12. Project Datasheet: ADC\_SAR\_Seq\_DieTemp\_PSoC4

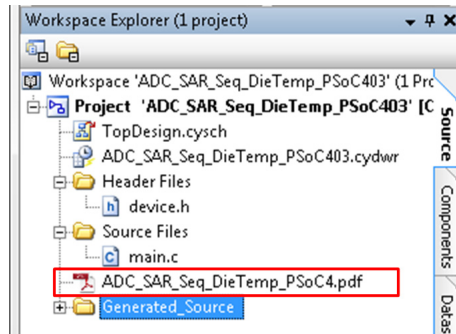

- You can view the die temperature value and ADC measured voltage through any terminal emulator program like PuTTY or HyperTerminal. Refer to chapter 5 of the [KitProg User Guide](#) for details on how to configure and use the software with KitProg. The UART used in the example uses configuration provided in [Table 5-1](#). The output with PuTTY software is shown in [Figure 5-13](#).

Table 5-1. UART Settings

UART Parameter	Setting
Data bits	8
Stop bits	None
Parity bits	None
Baud rate	115200 bps

Figure 5-13. ADC\_SAR\_Seq\_DieTemp\_PSoC4 Output in PuTTY

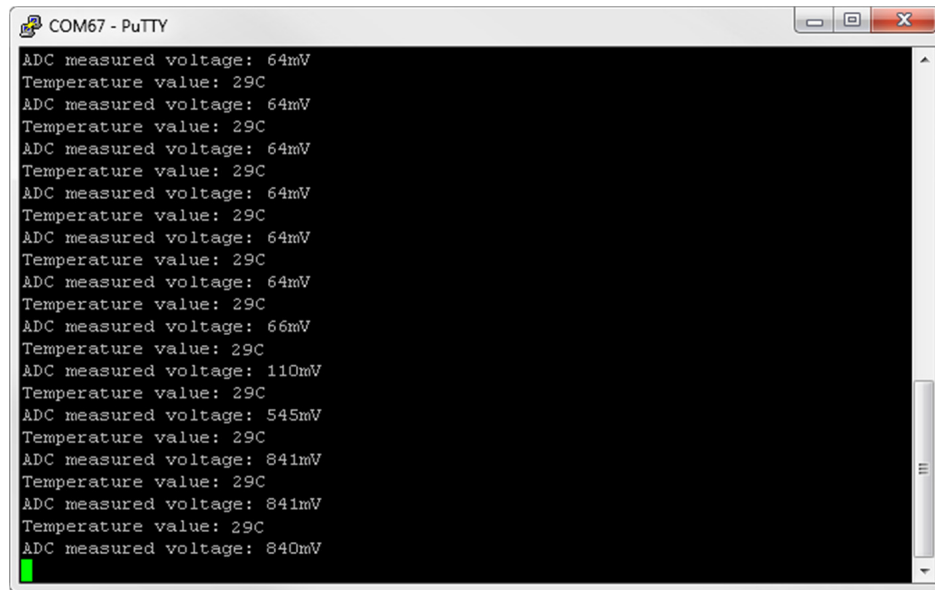

# A. Appendix



## A.1 PSoC 4 M-Series Prototyping Kit Schematics

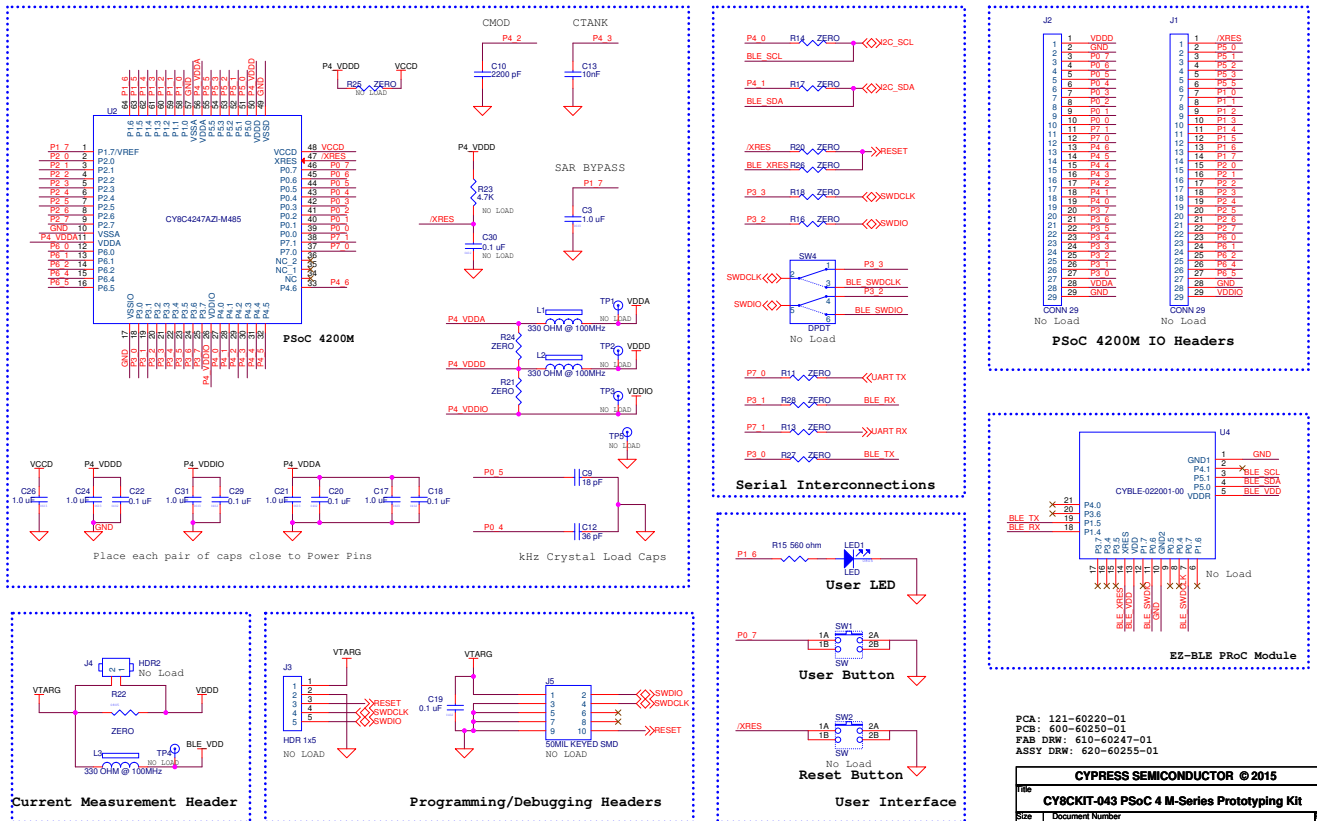

### Kitprog on-board Programmer / Debugger

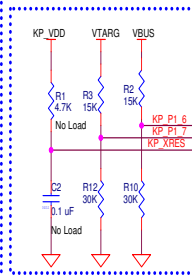
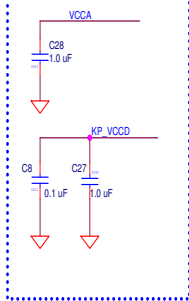
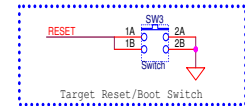
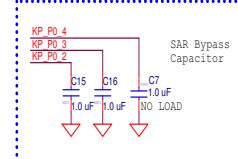
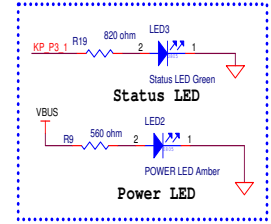
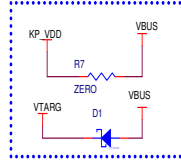
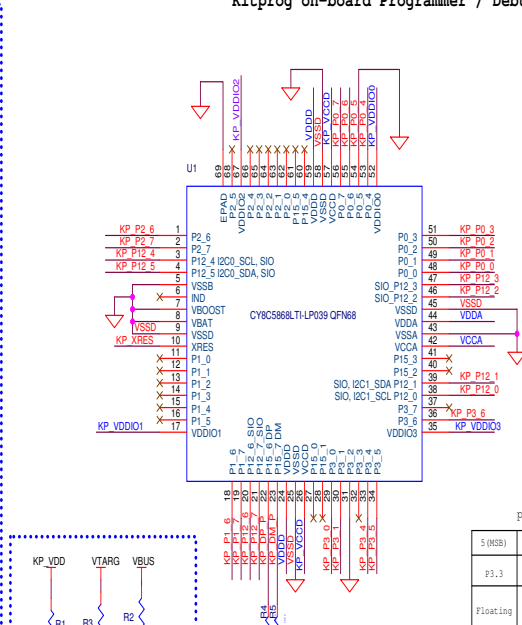
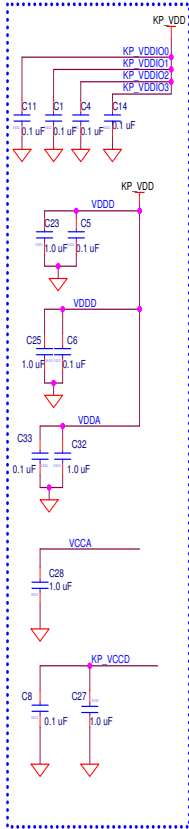

P3\_3, P3\_2, P0\_7, P0\_6, P0\_5, P0\_4 pins are reserved for HW REV ID

5 (MSB)	4	3	2	1	0 (LSB)
P3.3	P3.2	P0.7	P0.6	P0.5	P0.4
Floating	GND	Floating	Floating	GND	Floating

GND read as binary "1"  
Floating pin is read as binary "0"

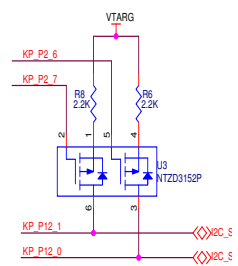

I2C & UART Connection

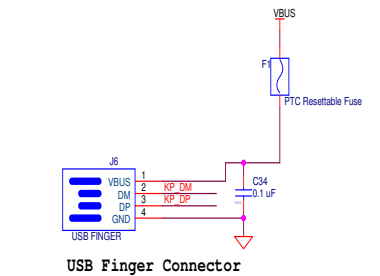

USB Finger Connector

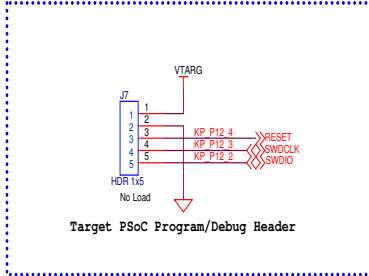

Target PSoC Program/Debug Header

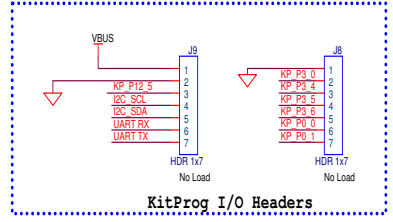

KitProg I/O Headers

PCA: 121-60220-01  
PCB: 600-60250-01  
FAB DRW: 610-60247-01  
ASSY DRW: 620-60255-01

CYPRESS SEMICONDUCTOR © 2015	
Title: <b>CY8CKIT-043 PSoC 4 M-Series Prototyping Kit</b>	
Size B	Document Number: <b>630-60252-01</b>
Date: Friday, June 12, 2015	Sheet 3 of 3

## A.2 Programming the PSoC 4 M-Series Prototyping Kit Using MiniProg3/KitProg

The target board allows you to program the PSoC 4200M device using a MiniProg3 or an external KitProg via the 5-pin SWD header or the 10-pin JTAG header. To do this, connect wires or a 5-pin 100-mil spaced header to J3 or a 10-pin JTAG header to J5 on the target board. The PSoC 4 M-Series Prototyping kit supports both power cycle and reset programming modes.

Figure A-1. Connecting CY8CKIT-043 to MiniProg3

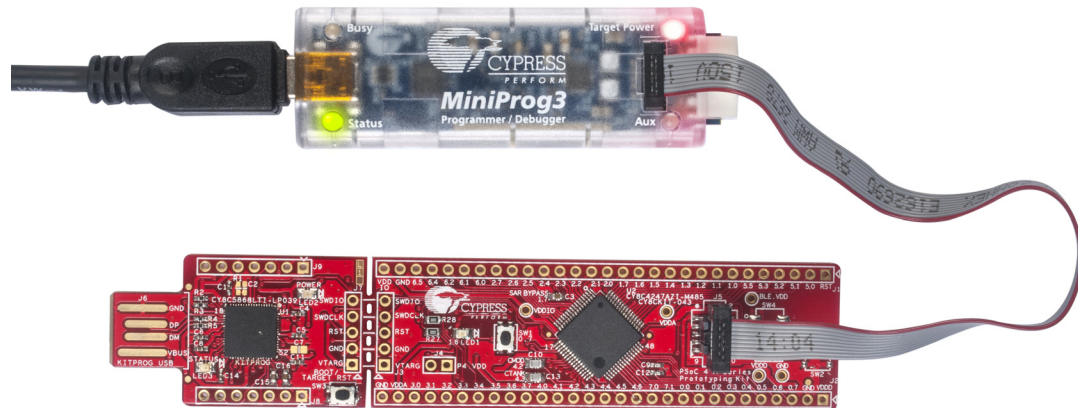

**Note:** CY8CKIT-002 MiniProg3 is not part of the PSoC 4 M-Series Prototyping kit contents and can be purchased from the [Cypress Online Store](#).

### A.3 Bill of Materials

Item	Qty	Reference	Value	Description	Manufacturer	Mfr Part Number
1	1	600-60250-01 REV03	-	PCB, 112 mm x 24.13 mm, High Tg, ENIG finish, 2 layer, Color = RED, Silk = WHITE	Cypress Semiconductor	600-60250-01
2	14	C1,C4,C5,C6,C8,C11,C14,C18,C19,C20,C22,C29,C33,C34	0.1 uFd	CAP CER 0.1UF 10V 10% X5R 0402	TDK Corporation	C1005X5R1A104K050 BA
3	13	C3,C15,C16,C17,C21,C23,C24,C25,C26,C27,C28,C31,C32	1.0 uFd	CAP CERAMIC 1.0UF 25V X5R 0603 10%	Taiyo Yuden	TMK107BJ105KA-T
4	1	C9	18 pF	CAP CER 18PF 50V 1% NP0 0402	Murata Electronics	GRM1555C1H180FA01 D
5	1	C10	2200 pFd	CAP CER 2200PF 50V 5% NP0 0805	Murata	GRM2165C1H222JA01 D
6	1	C12	36 pF	CAP CER 36PF 50V 5% NP0 0402	Murata Electronics	GRM1555C1H360JA01 D
7	1	C13	10000 pFd	CAP CER 10000PF 50V 5% NP0 0805	Murata	GRM2195C1H103JA01 D
8	1	D1	MBR0520L	DIODE SCHOTTKY 0.5A 20V SOD-123	Fairchild Semiconductor	MBR0520L
9	1	F1	PTC Resettable Fuse	FUSE, PTC Resettable, 0.50A, 16V, 1210, SMD	Bel Fuse Inc	OZCH0050FF2G
10	1	LED1	User LED BLUE	LED, BLUE, CLEAR, 0805, SMD	Lite-On Inc	LTST-C170TBKT
11	1	LED2	Power LED Amber	LED 595NM AMB DIFF 0805 SMD	Avago Technologies	HSMA-C170
12	1	LED3	Status LED Green	LED GREEN CLEAR 0805 SMD	Chicago Miniature	CMD17-21VGC/TR8
13	3	L1,L2,L3	330 OHM @ 100MHz	FILTER CHIP 330 OHM 1.5A 0603	Murata Electronics	BLM18SG331TN1D
14	2	R2,R3	15K	RES SMD 15K OHM 5% 1/10W 0402	Panasonic - ECG	ERJ-2GEJ153X
15	2	R4,R5	22E	RES SMD 22 OHM 1% 1/10W 0402	Panasonic - ECG	ERJ-2RKF22R0X
16	2	R6,R8	2.2K	RES 2.2K OHM 1/10W 5% 0603 SMD	Panasonic - ECG	ERJ-3GEYJ222V
17	2	R7,R22	ZERO	RES 0.0 OHM 1/8W 0805 SMD	Panasonic-ECG	ERJ-6GEY0R00V
18	1	R9	560 ohm	RES 560 OHM 1/10W 5% 0603 SMD	Panasonic - ECG	ERJ-3GEYJ561V
19	2	R10,R12	30K	RES SMD 30K OHM 5% 1/10W 0402	Panasonic - ECG	ERJ-2GEJ303X
20	12	R11,R13,R14,R16,R17,R18,R20,R21,R24,R26,R27,R28	ZERO	RES 0.0 OHM 1/8W 0603 SMD	Panasonic-ECG	ERJ-3GEY0R00V
21	1	R15	560 ohm	RES 560 OHM 1/8W 5% 0805 SMD	Panasonic - ECG	ERJ-6GEYJ561V

Item	Qty	Reference	Value	Description	Manufacturer	Mfr Part Number
22	1	R19	820 ohm	RES 820 OHM 1/8W 5% 0603 SMD	Panasonic - ECG	ERJ-3GEYJ821V
23	2	SW1,SW3	SW PUSH-BUTTON	SWITCH TACTILE SPST-NO 0.05A 32V	C&K Components	KMR221GLFS
24	1	U1	PSoC 5LP	68QFN PSoC 5LP chip for USB debug channel and USB-Serial interface	Cypress Semiconductor	CY8C5868LTI-LP039
25	1	U2	PSoC 4200M	68TQFP PSoC 4M	Cypress Semiconductor	CY8C4247AZI-M485
26	1	U3	DUAL PMOS	MOSFET 2P-CH 20V 430MA SOT-563	ON Semiconductor	NTZD3152PT1G
Label						
27	1	N/A	N/A	LBL, PCA Label, Vendor Code, Datecode, Serial Number 121-60220-01 Rev 03 (YYWWV-VXXXXX)	Cypress Semiconductor	
No load components						
28	2	C2,C30	0.1 uFd	CAP CER 0.1UF 10V 10% X5R 0402	TDK Corporation	C1005X5R1A104K050 BA
29	1	C7	1.0 uFd	CAP CERAMIC 1.0UF 25V X5R 0603 10%	Taiyo Yuden	TMK107BJ105KA-T
30	1	J4	HDR 1x2	CONN HEADR BRKWAY .100 02POS STR	TE Connectivity	9-146280-0-02
31	1	J5	50MIL KEYED SMD	CONN HEADER 10 PIN 50MIL KEYED SMD	Samtec	FTSH-105-01-L-DV-K
32	1	R1	4.7K	RES SMD 4.7K OHM 5% 1/10W 0402	Panasonic - ECG	ERJ-2GEJ472X
33	1	R25	ZERO	RES 0.0 OHM 1/8W 0805 SMD	Panasonic - ECG	ERJ-6GEY0R00V
34	1	R23	4.7K	RES 4.7K OHM 1/10W 5% 0603 SMD	Panasonic - ECG	ERJ-3GEYJ472V
35	1	SW2	SW PUSH-BUTTON	SWITCH TACTILE SPST-NO 0.05A 32V	C&K Components	KMR221GLFS
36	1	SW4	DPDT SW	SWITCH SLIDE DPDT 200MA 12V	Copal Electronics	CL-SB-22B-02T
37	1	TP5	BLACK	TEST POINT 43 HOLE 65 PLATED BLACK	Keystone Electronics	5001
38	4	TP1,TP2,TP3,TP4	RED	TEST POINT 43 HOLE 65 PLATED RED	Keystone Electronics	5000
39	1	U4	EZ-BLE	EZ-BLE PRoC BLE Module, 10 mm X 10 mm X 1.8 mm	Cypress Semiconductor	CYBLE-022001-00

# Revision History



## CY8CKIT-043 PSoC® 4 M-Series Prototyping Kit Guide Revision History

<b>Document Title: CY8CKIT-043 PSoC® 4 M-Series Prototyping Kit Guide</b>			
<b>Document Number: 001-97606</b>			
<b>Revision</b>	<b>Issue Date</b>	<b>Origin of Change</b>	<b>Description of Change</b>
**	06/25/2015	MSUR	New kit guide