

TAP2000 Series

Ultra High Power Planar Resistor



The Ohmite TAP2000 series offers 2000 watts of power dissipation when properly heatsinked. The design of the TAP series creates a constant pressure to the cooling plate of approximately 300 N for proper thermal flow. The TAP2000 is ideal for variable speed drives, power supplies, control devices, robotics, motor control and other power designs.

FEATURES

- 2,000 W operating power with proper heatsinking
- Non-Inductive design
- ROHS compliant
- High insulation & partial discharge performance
- Materials in accordance with UL 94 V-0



CHARACTERISTICS

Resistance value	0.15Ω ≤ 0.99Ω (HC-version); > 0.99Ω ≤ 6 KΩ (higher values on request)
Resistance tolerance	±5 % to ±10 %
Temp. coefficient	±150 ppm/°C Standard; lower TCR on special request for limited ohmic values
Power rating	2,000 W at 125°C bottom case temperature resp. 60°C heat sink temperature
Short time overload	2,400 W at 70°C for 10sec., ΔR = 0.4% max.
Max. working voltage	5,000 V DC = 3,500 V AC RMS (50 Hz); higher volt - age on request, not exceeding max. power
Max. cont. current	120 A
Electric strength voltage	7 kVrms / 50 Hz / 500 VA, test time 1 min. between terminal und case (up to 12 kVrms on request). Voltages above 10 kVrms are tested at DC equivalent to avoid pre damage of component
Partial discharge	4 kVrms < 10 pC (up to 7 kVrms < 10 pC on request) acc. to IEC 60270
Pulse peak current	up to 1,500 A depending on pulse length and frequency (ask for details)
Insulation resistance	> 10 GΩ at 1,000 V
Single shot voltage	up to 12 kV norm wave (1.5/50 μsec)
Creeping distance	> 42mm (standard, higher on request)
Air distance	> 14mm (standard, higher on request)
Inductance	≥ 80 nH (typical), measuring frequency 10 kHz
Capacity/mass	≥ 120 pF (typical), measuring frequency 10 kHz
Capacity/parallel	≥ 40 pF (typical), measuring frequency 10 kHz
Oper. temperature	-55°C to +155°C
Mounting	torque for contacts 1.8 Nm to 2 Nm; torque 1.6 Nm to 1.8 Nm M4 screws
Weight	~120 g

Base Plate	Alumina ceramic metalized film on the base plate for improved heat transfer
Encapsulation	Resin-filled epoxy casing with large creeping distance to mass, large air distance between the terminals and high insulation resistance (CTI 600)
Resistance Element	Special design for low inductance and capacitance values. The element demonstrates stability while covering high wattage and pulse loading
Contacts	<ul style="list-style-type: none"> • Various sleeves for increasing creeping distance up to 85mm • Contacts standard M5 (M4 on special request - connection screw thread max. 7mm)

Derating

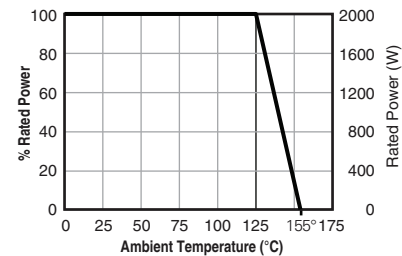

Derating (thermal resist.) 66.6 W/K (0.015 K/W)

Power rating: 2,000 W at 125°C bottom case temperature

Please ask for detailed mounting procedure!

Best results can be reached by using a thermal transfer compound with a heat conductivity of at least 2.9 W/mK. The flatness of the cooling plate must be better than 0.05 mm overall. Surface roughness should not exceed 6.4 μm.

TAP2000 Series

Ultra High Power Planar Resistor

PERFORMANCE DATA

Test	Method	ΔR
Short time overload	2,400 W/10sec.	0.40%
Humidity steady state	56 days/40°C/95%	0.25%
Temp. Cycling	-55/+125/5cycles	0.20%
Shock	40g/4,000 times	0.25%
Vibrations	2-500Hz/10g	0.25%
Load life	3,000cyl PN 30 min. on / 30 min off	0.40%
Terminal strength	200 N for hexa. thread con - tacts	0.05%

test methods are according to IEC 60068-2

DIMENSIONS

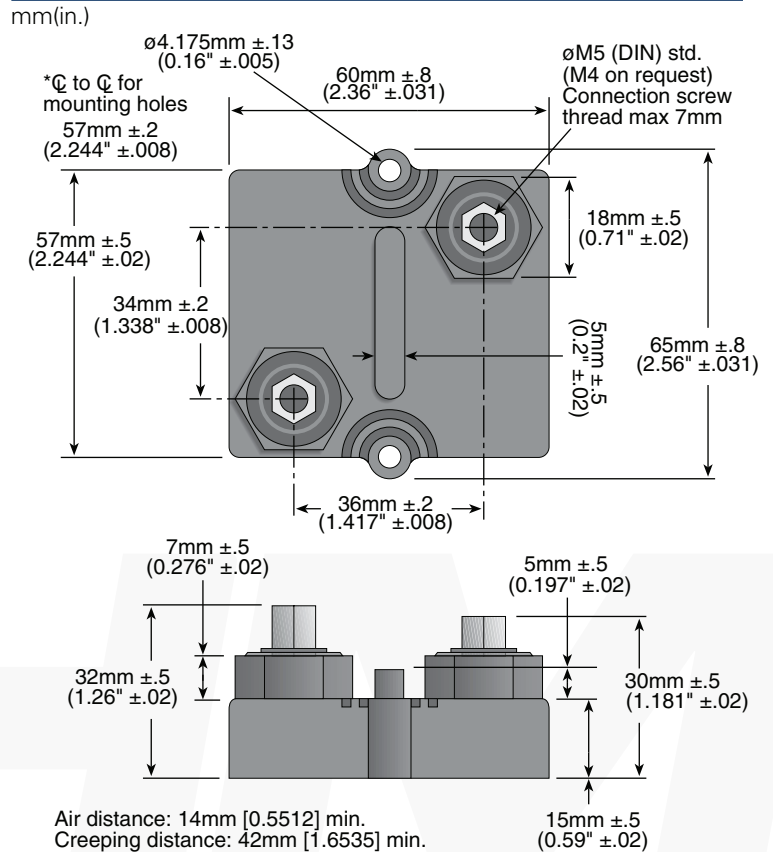

ORDERING INFORMATION

RoHS compliant

TAP2000HC K5R0E

Series High-current for values below 1Ω Tolerance K = 10% Resistance

THIS PRODUCT IS DESIGNED FOR USE WITH PROPER HEATSINKING.

Maximum base plate of temperature the resistor must be monitored and kept within specified limits to establish the power rating. Best technique is to attach a thermocouple to the side of the base plate of the resistor. Temperature of plastic housing or heat sink cannot be used to establish rating of the resistor. The Ohmite CP4 (<https://www.ohmite.com/cp4-series-chillplate/>) is an example of properly designed heat sink.