

bq4050 CEDV Gas Gauge and Protection Solution for 1-Series to 4-Series Cell Li-Ion Battery Packs

1 Features

- High-Side Protection N-CH FET Drive Enables Serial Bus Communication During Fault Conditions
- Cell Balancing with Internal Bypass Optimizes Battery Health
- Diagnostic Lifetime Data Monitor and Black Box Recorder for Failure Analysis
- Full Array of Programmable Protection Features: Voltage, Current, Temperature
- JEITA Charge Algorithms Support Smart Charging
- Analog Front End with Two Independent ADCs
 - Simultaneous Current and Voltage Sampling
 - High-Accuracy Coulomb Counter with Input Offset Error < 1 μV (Typical)
- Supports Battery Trip Point (BTP) Function for Windows[®] Integration
- LED Display for State of Charge and Battery Status Indication
- 100-KHz SMBus v1.1 Communications Interface for Programming and Data Access with Alternate 400-KHz Mode
- SHA-1 Authentication Responder for Increased Battery Pack Security
- Compact 32-Pin VQFN Package (RSM)

2 Applications

- Notebooks
- Medical and Test Equipment
- Portable Instrumentation
- Cordless Vacuum Cleaners and Vacuum Robots

3 Description

The Texas Instruments bq4050 device, incorporating Compensated End-of-Discharge Voltage (CEDV) technology, is a highly integrated, accurate, 1-series to 4-series cell gas gauge and protection solution, enabling autonomous charger control and cell balancing.

The bq4050 device provides a fully integrated pack-based solution with a flash programmable custom reduced instruction-set CPU (RISC), safety protection, and authentication for Li-Ion and Li-Polymer battery packs.

The bq4050 gas gauge communicates via an SMBus-compatible interface and combines an ultra-low power, high-speed TI bqBMP processor, high-accuracy analog measurement capabilities, integrated flash memory, an array of peripheral and communication ports, an N-CH FET drive, and a SHA-1 Authentication transform responder into a complete, high-performance battery management solution.

Device Information⁽¹⁾

PART NUMBER	PACKAGE	BODY SIZE (NOM)
bq4050	VQFN (32)	4.00 mm x 4.00 mm

(1) For all available packages, see the orderable addendum at the end of this data sheet.

Simplified Schematic

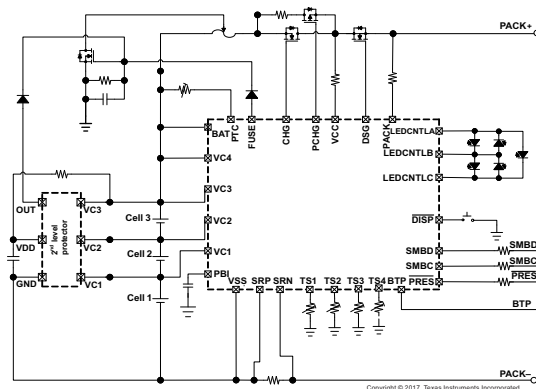

Table of Contents

1	Features	1			
2	Applications	1			
3	Description	1			
4	Revision History	2			
5	Pin Configuration and Functions	3			
6	Specifications	7			
	6.1 Absolute Maximum Ratings	7			
	6.2 ESD Ratings	7			
	6.3 Recommended Operating Conditions	8			
	6.4 Thermal Information	8			
	6.5 Electrical Characteristics: Supply Current	8			
	6.6 Electrical Characteristics: Power Supply Control	9			
	6.7 Electrical Characteristics: AFE Power-On Reset	9			
	6.8 Electrical Characteristics: AFE Watchdog Reset and Wake Timer	9			
	6.9 Electrical Characteristics: Current Wake Comparator	9			
	6.10 Electrical Characteristics: VC1, VC2, VC3, VC4, BAT, PACK	10			
	6.11 Electrical Characteristics: SMBD, SMBC	10			
	6.12 Electrical Characteristics: PRES, BTP_INT, DISP	10			
	6.13 Electrical Characteristics: LEDCNTLA, LEDCNTLB, LEDCNTLC	11			
	6.14 Electrical Characteristics: Coulomb Counter	11			
	6.15 Electrical Characteristics: CC Digital Filter	11			
	6.16 Electrical Characteristics: ADC	12			
	6.17 Electrical Characteristics: ADC Digital Filter	12			
	6.18 Electrical Characteristics: CHG, DSG FET Drive	12			
	6.19 Electrical Characteristics: PCHG FET Drive	13			
	6.20 Electrical Characteristics: FUSE Drive	13			
	6.21 Electrical Characteristics: Internal Temperature Sensor	13			
	6.22 Electrical Characteristics: TS1, TS2, TS3, TS4	14			
	6.23 Electrical Characteristics: PTC, PTCEN	14			
	6.24 Electrical Characteristics: Internal 1.8-V LDO	14			
	6.25 Electrical Characteristics: High-Frequency Oscillator	14			
	6.26 Electrical Characteristics: Low-Frequency Oscillator	15			
	6.27 Electrical Characteristics: Voltage Reference 1	15			
	6.28 Electrical Characteristics: Voltage Reference 2	15			
	6.29 Electrical Characteristics: Instruction Flash	15			
	6.30 Electrical Characteristics: Data Flash	15			
	6.31 Electrical Characteristics: OCD, SCC, SCD1, SCD2 Current Protection Thresholds	16			
	6.32 Timing Requirements: OCD, SCC, SCD1, SCD2 Current Protection Timing	17			
	6.33 Timing Requirements: SMBus	17			
	6.34 Timing Requirements: SMBus XL	18			
	6.35 Typical Characteristics	19			
7	Detailed Description	22			
	7.1 Overview	22			
	7.2 Functional Block Diagram	22			
	7.3 Feature Description	23			
	7.4 Device Functional Modes	26			
8	Applications and Implementation	27			
	8.1 Application Information	27			
	8.2 Typical Applications	28			
9	Power Supply Recommendations	42			
10	Layout	42			
	10.1 Layout Guidelines	42			
	10.2 Layout Example	44			
11	Device and Documentation Support	46			
	11.1 Documentation Support	46			
	11.2 Community Resources	46			
	11.3 Trademarks	46			
	11.4 Electrostatic Discharge Caution	46			
	11.5 Glossary	46			
12	Mechanical, Packaging, and Orderable Information	46			

4 Revision History

NOTE: Page numbers for previous revisions may differ from page numbers in the current version.

Changes from Revision A (April 2016) to Revision B	Page
• Changed Applications	1

5 Pin Configuration and Functions

RSM Package
32-Pin VQFN with Exposed Thermal Pad
Top View

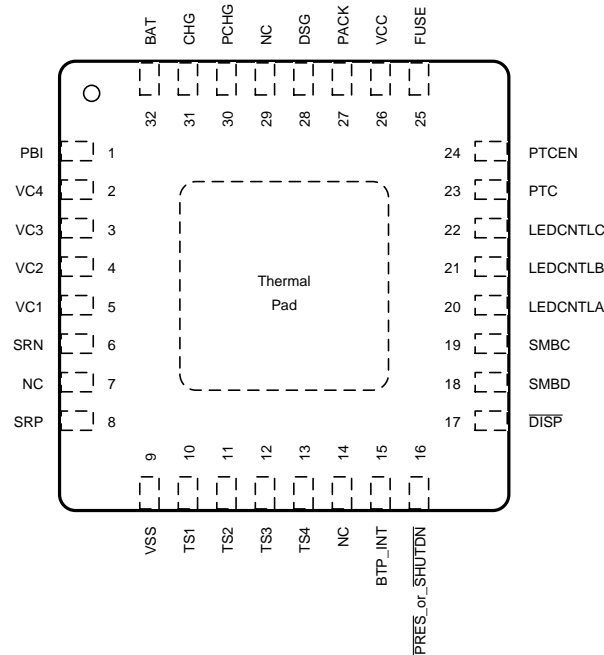

Pin Functions

PIN		TYPE	DESCRIPTION
NAME	NUMBER		
PBI	1	P ⁽¹⁾	Power supply backup input pin
VC4	2	IA	Sense voltage input pin for the most positive cell, and balance current input for the most positive cell
VC3	3	IA	Sense voltage input pin for the second most positive cell, balance current input for the second most positive cell, and return balance current for the most positive cell
VC2	4	IA	Sense voltage input pin for the third most positive cell, balance current input for the third most positive cell, and return balance current for the second most positive cell
VC1	5	IA	Sense voltage input pin for the least positive cell, balance current input for the least positive cell, and return balance current for the third most positive cell
SRN	6	I	Analog input pin connected to the internal coulomb counter peripheral for integrating a small voltage between SRP and SRN where SRP is the top of the sense resistor.
NC	7	—	Not internally connected. Connect to V _{SS} .
SRP	8	I	Analog input pin connected to the internal coulomb counter peripheral for integrating a small voltage between SRP and SRN where SRP is the top of the sense resistor.
VSS	9	P	Device ground
TS1	10	IA	Temperature sensor 1 thermistor input pin
TS2	11	IA	Temperature sensor 2 thermistor input pin
TS3	12	IA	Temperature sensor 3 thermistor input pin
TS4	13	IA	Temperature sensor 4 thermistor input pin
NC	14	—	Not internally connected. Connect to V _{SS} .
BTP_INT	15	O	Battery Trip Point (BTP) interrupt output
PRES or SHUTDOWN	16	I	Host system present input for removable battery pack or emergency system shutdown input for embedded packs

(1) P = Power Connection, O = Digital Output, AI = Analog Input, I = Digital Input, I/OD = Digital Input/Output

Pin Functions (continued)

PIN		TYPE	DESCRIPTION
NAME	NUMBER		
DISP	17	—	Display control for LEDs
SMBD	18	I/OD	SMBus data pin
SMBC	19	I/OD	SMBus clock pin
LEDCNTLA	20	—	LED display segment that drives the external LEDs depending on the firmware configuration
LEDCNTLB	21	—	LED display segment that drives the external LEDs depending on the firmware configuration
LEDCNTLC	22	—	LED display segment that drives the external LEDs depending on the firmware configuration
PTC	23	IA	Safety PTC thermistor input pin. To disable, connect PTC and PTCEN to V _{SS} .
PTCEN	24	IA	Safety PTC thermistor enable input pin. Connect to BAT. To disable, connect PTC and PTCEN to V _{SS} .
FUSE	25	O	Fuse drive output pin
VCC	26	P	Secondary power supply input
PACK	27	IA	Pack sense input pin
DSG	28	O	NMOS Discharge FET drive output pin
NC	29	—	Not internally connected. Connect to V _{SS} .
PCHG	30	O	PMOS Precharge FET drive output pin
CHG	31	O	NMOS Charge FET drive output pin
BAT	32	P	Primary power supply input pin

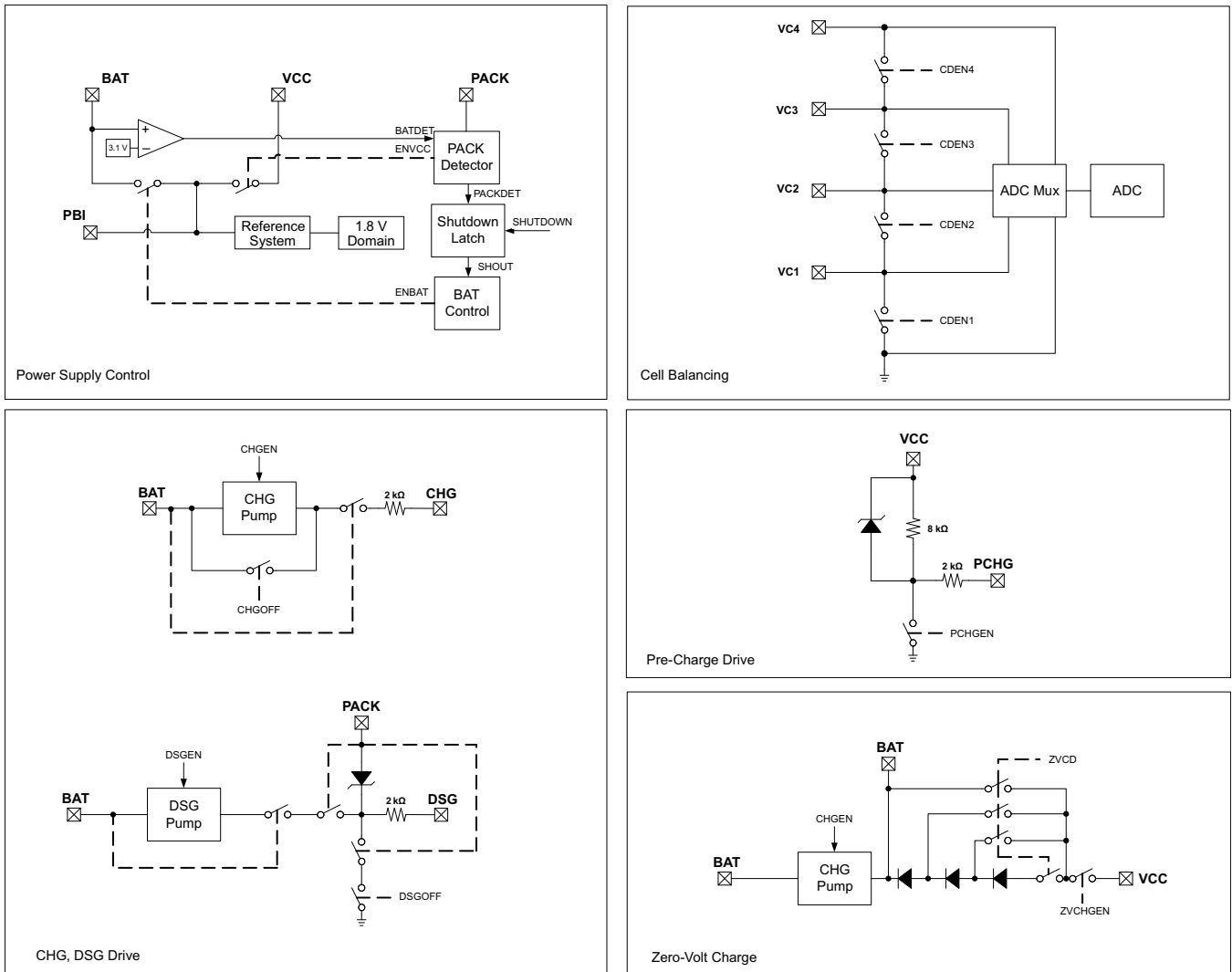

Figure 1. Pin Equivalent Diagram 1

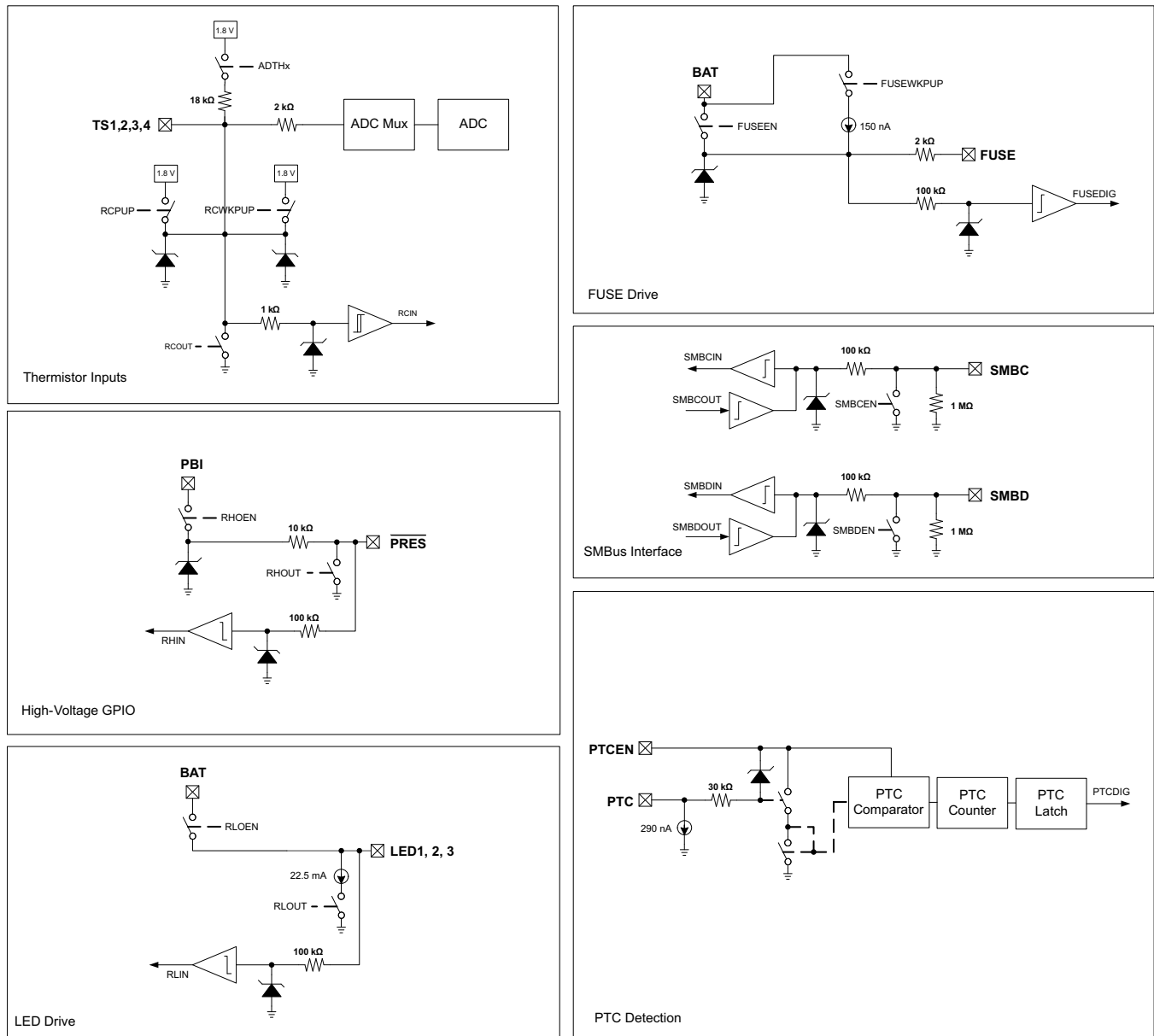

Figure 2. Pin Equivalent Diagram 2

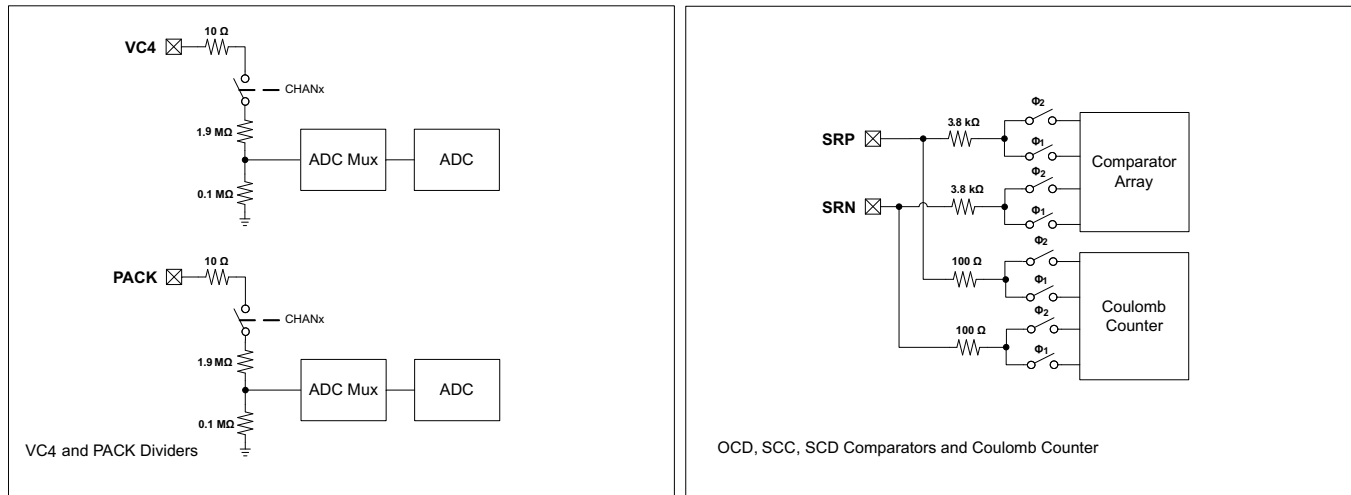

Figure 3. Pin Equivalent Diagram 3

6 Specifications

6.1 Absolute Maximum Ratings

Over-operating free-air temperature range (unless otherwise noted)⁽¹⁾

		MIN	MAX	UNIT
Supply voltage range, V _{CC}	BAT, VCC, PBI	-0.3	30	V
Input voltage range, V _{IN}	PACK, SMBC, SMBD, $\overline{\text{PRES}}$ or $\overline{\text{SHUTDN}}$, BTP_INT, $\overline{\text{DISP}}$	-0.3	30	V
	TS1, TS2, TS3, TS4	-0.3	V _{REG} + 0.3	V
	PTC, PTCEN, LEDCNTLA, LEDCNTLB, LEDCNTLC	-0.3	V _{BAT} + 0.3	V
	SRP, SRN	-0.3	0.3	V
	VC4	VC3 - 0.3	VC3 + 8.5 V, or VSS + 30	V
	VC3	VC2 - 0.3	VC2 + 8.5 V, or VSS + 30	V
Output voltage range, V _O	VC2	VC1 - 0.3	VC1 + 8.5 V, or VSS + 30	V
	VC1	VSS - 0.3	VSS + 8.5 V, or VSS + 30 V	V
	CHG, DSG	-0.3	32	
Maximum VSS current, I _{SS}	PCHG, FUSE	-0.3	30	V
			50	mA
T _{STG}	Storage temperature	-65	150	°C
Lead temperature (soldering, 10 s), T _{SOLDER}			300	°C

- (1) Stresses beyond those listed under *absolute maximum ratings* may cause permanent damage to the device. These are stress ratings only, and functional operation of the device at these or any other conditions beyond those indicated under *recommended operating conditions* is not implied. Exposure to absolute-maximum-rated conditions for extended periods may affect device reliability.

6.2 ESD Ratings

		VALUE	UNIT
V _(ESD)	Electrostatic discharge	Human-body model (HBM), per ANSI/ESDA/JEDEC JS-001 ⁽¹⁾	±2000
		Charged-device model (CDM), per JEDEC specification JESD22-C101 ⁽²⁾	±500

(1) JEDEC document JEP155 states that 500-V HBM allows safe manufacturing with a standard ESD control process.

(2) JEDEC document JEP157 states that 250-V CDM allows safe manufacturing with a standard ESD control process.

6.3 Recommended Operating Conditions

Typical values stated where $T_A = 25^\circ\text{C}$ and $V_{CC} = 14.4\text{ V}$, Min/Max values stated where $T_A = -40^\circ\text{C}$ to 85°C and $V_{CC} = 2.2\text{ V}$ to 26 V (unless otherwise noted)

			MIN	NOM	MAX	UNIT
V_{CC}	Supply voltage	BAT, VCC, PBI	2.2		26	V
$V_{SHUTDOWN-}$	Shutdown voltage	$V_{PACK} < V_{SHUTDOWN-}$	1.8	2.0	2.2	V
$V_{SHUTDOWN+}$	Start-up voltage	$V_{PACK} > V_{SHUTDOWN-} + V_{HYS}$	2.05	2.25	2.45	V
V_{HYS}	Shutdown voltage hysteresis	$V_{SHUTDOWN+} - V_{SHUTDOWN-}$		250		mV
V_{IN}	Input voltage range	PACK, SMBC, SMBD, \overline{PRES} , BTP_IN, \overline{DISP}			26	V
		TS1, TS2, TS3, TS4			V_{REG}	
		PTC, PTCEN, LEDCNTLA, LEDCNTLB, LEDCNTLC			V_{BAT}	
		SRP, SRN	-0.2		0.2	
		VC4	V_{VC3}		$V_{VC3} + 5$	
		VC3	V_{VC2}		$V_{VC2} + 5$	
		VC2	V_{VC1}		$V_{VC1} + 5$	
	VC1	V_{VSS}		$V_{VSS} + 5$		
V_O	Output voltage range	CHG, DSG, PCHG, FUSE			26	V
C_{PBI}	External PBI capacitor		2.2			μF
T_{OPR}	Operating temperature		-40		85	$^\circ\text{C}$

6.4 Thermal Information

THERMAL METRIC ⁽¹⁾		bq4050		UNIT
		RSM (QFN)		
		32 PINS		
$R_{\theta JA, \text{High K}}$	Junction-to-ambient thermal resistance	47.4		$^\circ\text{C/W}$
$R_{\theta JC(\text{top})}$	Junction-to-case(top) thermal resistance	40.3		$^\circ\text{C/W}$
$R_{\theta JB}$	Junction-to-board thermal resistance	14.7		$^\circ\text{C/W}$
Ψ_{JT}	Junction-to-top characterization parameter	0.8		$^\circ\text{C/W}$
Ψ_{JB}	Junction-to-board characterization parameter	14.4		$^\circ\text{C/W}$
$R_{\theta JC(\text{bottom})}$	Junction-to-case(bottom) thermal resistance	3.8		$^\circ\text{C/W}$

(1) For more information about traditional and new thermal metrics, see the Semiconductor and IC Package Thermal Metrics application report, [SPRA953](#).

6.5 Electrical Characteristics: Supply Current

Typical values stated where $T_A = 25^\circ\text{C}$ and $V_{CC} = 14.4\text{ V}$, Min/Max values stated where $T_A = -40^\circ\text{C}$ to 85°C and $V_{CC} = 2.2\text{ V}$ to 20 V (unless otherwise noted)

PARAMETER		TEST CONDITIONS	MIN	TYP	MAX	UNIT
I_{NORMAL}	NORMAL mode	CHG on, DSG on, no Flash write		336		μA
I_{SLEEP}	SLEEP mode	CHG off, DSG on, no SBS communication		75		μA
		CHG off, DSG off, no SBS communication		52		
$I_{SHUTDOWN}$	SHUTDOWN mode			1.6		μA

6.6 Electrical Characteristics: Power Supply Control

Typical values stated where $T_A = 25^\circ\text{C}$ and $V_{CC} = 14.4\text{ V}$, Min/Max values stated where $T_A = -40^\circ\text{C}$ to 85°C and $V_{CC} = 2.2\text{ V}$ to 26 V (unless otherwise noted)

PARAMETER	TEST CONDITIONS	MIN	TYP	MAX	UNIT
$V_{\text{SWITCHOVER-}}$	BAT to V_{CC} switchover voltage $V_{\text{BAT}} < V_{\text{SWITCHOVER-}}$	1.95	2.1	2.2	V
$V_{\text{SWITCHOVER+}}$	V_{CC} to BAT switchover voltage $V_{\text{BAT}} > V_{\text{SWITCHOVER-}} + V_{\text{HYS}}$	2.9	3.1	3.25	V
V_{HYS}	Switchover voltage hysteresis $V_{\text{SWITCHOVER+}} - V_{\text{SWITCHOVER-}}$		1000		mV
I_{LKG}	BAT pin, BAT = 0 V, $V_{CC} = 25\text{ V}$, PACK = 25 V			1	μA
	PACK pin, BAT = 25 V, $V_{CC} = 0\text{ V}$, PACK = 0 V			1	
	BAT and PACK terminals, BAT = 0 V, $V_{CC} = 0\text{ V}$, PACK = 0 V, PBI = 25 V			1	
R_{PD}	Internal pulldown resistance PACK	30	40	50	$\text{k}\Omega$

6.7 Electrical Characteristics: AFE Power-On Reset

Typical values stated where $T_A = 25^\circ\text{C}$ and $V_{CC} = 14.4\text{ V}$, Min/Max values stated where $T_A = -40^\circ\text{C}$ to 85°C and $V_{CC} = 2.2\text{ V}$ to 26 V (unless otherwise noted)

PARAMETER	TEST CONDITIONS	MIN	TYP	MAX	UNIT
$V_{\text{REGIT-}}$	Negative-going voltage input V_{REG}	1.51	1.55	1.59	V
V_{HYS}	Power-on reset hysteresis $V_{\text{REGIT+}} - V_{\text{REGIT-}}$	70	100	130	mV
t_{RST}	Power-on reset time	200	300	400	μs

6.8 Electrical Characteristics: AFE Watchdog Reset and Wake Timer

Typical values stated where $T_A = 25^\circ\text{C}$ and $V_{CC} = 14.4\text{ V}$, Min/Max values stated where $T_A = -40^\circ\text{C}$ to 85°C and $V_{CC} = 2.2\text{ V}$ to 26 V (unless otherwise noted)

PARAMETER	TEST CONDITIONS	MIN	TYP	MAX	UNIT
t_{WDT}	AFE watchdog timeout $t_{\text{WDT}} = 500$	372	500	628	ms
	$t_{\text{WDT}} = 1000$	744	1000	1256	
	$t_{\text{WDT}} = 2000$	1488	2000	2512	
	$t_{\text{WDT}} = 4000$	2976	4000	5024	
t_{WAKE}	AFE wake timer $t_{\text{WAKE}} = 250$	186	250	314	ms
	$t_{\text{WAKE}} = 500$	372	500	628	
	$t_{\text{WAKE}} = 1000$	744	1000	1256	
	$t_{\text{WAKE}} = 512$	1488	2000	2512	
t_{FETOFF}	FET off delay after reset $t_{\text{FETOFF}} = 512$	409	512	614	ms

6.9 Electrical Characteristics: Current Wake Comparator

Typical values stated where $T_A = 25^\circ\text{C}$ and $V_{CC} = 14.4\text{ V}$, Min/Max values stated where $T_A = -40^\circ\text{C}$ to 85°C and $V_{CC} = 2.2\text{ V}$ to 26 V (unless otherwise noted)

PARAMETER	TEST CONDITIONS	MIN	TYP	MAX	UNIT
V_{WAKE}	Wake voltage threshold $V_{\text{WAKE}} = \pm 0.625\text{ mV}$	± 0.3	± 0.625	± 0.9	mV
	$V_{\text{WAKE}} = \pm 1.25\text{ mV}$	± 0.6	± 1.25	± 1.8	
	$V_{\text{WAKE}} = \pm 2.5\text{ mV}$	± 1.2	± 2.5	± 3.6	
	$V_{\text{WAKE}} = \pm 5\text{ mV}$	± 2.4	± 5.0	± 7.2	

Electrical Characteristics: Current Wake Comparator (continued)

Typical values stated where $T_A = 25^\circ\text{C}$ and $V_{CC} = 14.4\text{ V}$, Min/Max values stated where $T_A = -40^\circ\text{C}$ to 85°C and $V_{CC} = 2.2\text{ V}$ to 26 V (unless otherwise noted)

PARAMETER	TEST CONDITIONS	MIN	TYP	MAX	UNIT
$V_{\text{WAKE(DRIFT)}}$	Temperature drift of V_{WAKE} accuracy		0.5%		$^\circ\text{C}$
t_{WAKE}	Time from application of current to wake interrupt			700	μs
$t_{\text{WAKE(SU)}}$	Wake comparator startup time		500	1000	μs

6.10 Electrical Characteristics: VC1, VC2, VC3, VC4, BAT, PACK

Typical values stated where $T_A = 25^\circ\text{C}$ and $V_{CC} = 14.4\text{ V}$, Min/Max values stated where $T_A = -40^\circ\text{C}$ to 85°C and $V_{CC} = 2.2\text{ V}$ to 26 V (unless otherwise noted)

PARAMETER	TEST CONDITIONS	MIN	TYP	MAX	UNIT	
K	VC1–VSS, VC2–VC1, VC3–VC2, VC4–VC3	0.1980	0.2000	0.2020	—	
	BAT–VSS, PACK–VSS	0.049	0.050	0.051		
	V_{REF2}	0.490	0.500	0.510		
V_{IN}	VC1–VSS, VC2–VC1, VC3–VC2, VC4–VC3	–0.2		5	V	
	BAT–VSS, PACK–VSS	–0.2		20		
I_{LKG}	VC1, VC2, VC3, VC4, cell balancing off, cell detach detection off, ADC multiplexer off			1	μA	
R_{CB}	Internal cell balance resistance	$R_{\text{DS(ON)}}$ for internal FET switch at $2\text{ V} < V_{\text{DS}} < 4\text{ V}$			200	Ω
I_{CD}	Internal cell detach check current	$V_{\text{Cx}} > V_{\text{SS}} + 0.8\text{ V}$	30	50	70	μA

6.11 Electrical Characteristics: SMBD, SMBC

Typical values stated where $T_A = 25^\circ\text{C}$ and $V_{CC} = 14.4\text{ V}$, Min/Max values stated where $T_A = -40^\circ\text{C}$ to 85°C and $V_{CC} = 2.2\text{ V}$ to 26 V (unless otherwise noted)

PARAMETER	TEST CONDITIONS	MIN	TYP	MAX	UNIT	
V_{IH}	Input voltage high	SMBC, SMBD, $V_{\text{REG}} = 1.8\text{ V}$			1.3	V
V_{IL}	Input voltage low	SMBC, SMBD, $V_{\text{REG}} = 1.8\text{ V}$			0.8	V
V_{OL}	Output low voltage	SMBC, SMBD, $V_{\text{REG}} = 1.8\text{ V}$, $I_{\text{OL}} = 1.5\text{ mA}$			0.4	V
C_{IN}	Input capacitance		5		pF	
I_{LKG}	Input leakage current			1	μA	
R_{PD}	Pulldown resistance	0.7	1.0	1.3	M Ω	

6.12 Electrical Characteristics: $\overline{\text{PRES}}$, $\overline{\text{BTP_INT}}$, $\overline{\text{DISP}}$

Typical values stated where $T_A = 25^\circ\text{C}$ and $V_{CC} = 14.4\text{ V}$, Min/Max values stated where $T_A = -40^\circ\text{C}$ to 85°C and $V_{CC} = 2.2\text{ V}$ to 26 V (unless otherwise noted)

PARAMETER	TEST CONDITIONS	MIN	TYP	MAX	UNIT	
V_{IH}	High-level input				1.3	V
V_{IL}	Low-level input				0.55	V
V_{OH}	Output voltage high	$V_{\text{BAT}} > 5.5\text{ V}$, $I_{\text{OH}} = -0\text{ }\mu\text{A}$			3.5	V
		$V_{\text{BAT}} > 5.5\text{ V}$, $I_{\text{OH}} = -10\text{ }\mu\text{A}$			1.8	
V_{OL}	Output voltage low	$I_{\text{OL}} = 1.5\text{ mA}$			0.4	V
C_{IN}	Input capacitance		5		pF	
I_{LKG}	Input leakage current			1	μA	

Electrical Characteristics: $\overline{\text{PRES}}$, $\overline{\text{BTP_INT}}$, $\overline{\text{DISP}}$ (continued)

Typical values stated where $T_A = 25^\circ\text{C}$ and $V_{CC} = 14.4\text{ V}$, Min/Max values stated where $T_A = -40^\circ\text{C}$ to 85°C and $V_{CC} = 2.2\text{ V}$ to 26 V (unless otherwise noted)

PARAMETER	TEST CONDITIONS	MIN	TYP	MAX	UNIT
R_{O}	Output reverse resistance Between $\overline{\text{PRES}}$ or $\overline{\text{BTP_INT}}$ or $\overline{\text{DISP}}$ and PBI	8			k Ω

6.13 Electrical Characteristics: LEDCNTLA, LEDCNTLB, LEDCNTLC

Typical values stated where $T_A = 25^\circ\text{C}$ and $V_{CC} = 14.4\text{ V}$, Min/Max values stated where $T_A = -40^\circ\text{C}$ to 85°C and $V_{CC} = 2.2\text{ V}$ to 26 V (unless otherwise noted)

PARAMETER	TEST CONDITIONS	MIN	TYP	MAX	UNIT
V_{IH}	High-level input	1.45			V
V_{IL}	Low-level input			0.55	V
V_{OH}	Output voltage high $V_{BAT} > 3.0\text{ V}$, $I_{OH} = -22.5\text{ mA}$	$V_{BAT} - 1.6$			V
V_{OL}	Output voltage low $I_{OL} = 1.5\text{ mA}$			0.4	V
I_{SC}	High level output current protection	-30	-45	-6 0	mA
I_{OL}	Low level output current $V_{BAT} > 3.0\text{ V}$, $V_{OH} = 0.4\text{ V}$	15.75	22.5	29.25	mA
$I_{LEDCNTLx}$	Current matching between LEDCNTLx $V_{BAT} = V_{LEDCNTLx} + 2.5\text{ V}$		$\pm 1\%$		
C_{IN}	Input capacitance		20		pF
I_{LKG}	Input leakage current			1	μA
$f_{LEDCNTLx}$	Frequency of LED pattern		124		Hz

6.14 Electrical Characteristics: Coulomb Counter

Typical values stated where $T_A = 25^\circ\text{C}$ and $V_{CC} = 14.4\text{ V}$, Min/Max values stated where $T_A = -40^\circ\text{C}$ to 85°C and $V_{CC} = 2.2\text{ V}$ to 26 V (unless otherwise noted)

PARAMETER	TEST CONDITIONS	MIN	TYP	MAX	UNIT
Input voltage range		-0.1		0.1	V
Full scale range		$-V_{REF1}/10$		$V_{REF1}/10$	V
Integral nonlinearity ⁽¹⁾	16-bit, best fit over input voltage range		± 5.2	± 22.3	LSB
Offset error	16-bit, Post-calibration		± 5	± 10	μV
Offset error drift	15-bit + sign, Post-calibration		0.2	0.3	$\mu\text{V}/^\circ\text{C}$
Gain error	15-bit + sign, over input voltage range		$\pm 0.2\%$	$\pm 0.8\%$	FSR
Gain error drift	15-bit + sign, over input voltage range			150	PPM/ $^\circ\text{C}$
Effective input resistance		2.5			M Ω

(1) $1\text{ LSB} = V_{REF1}/(10 \times 2^N) = 1.215/(10 \times 2^{15}) = 3.71\text{ }\mu\text{V}$

6.15 Electrical Characteristics: CC Digital Filter

Typical values stated where $T_A = 25^\circ\text{C}$ and $V_{CC} = 14.4\text{ V}$, Min/Max values stated where $T_A = -40^\circ\text{C}$ to 85°C and $V_{CC} = 2.2\text{ V}$ to 26 V (unless otherwise noted)

PARAMETER	TEST CONDITIONS	MIN	TYP	MAX	UNIT
Conversion time	Single conversion		250		ms
Effective resolution	Single conversion	15			Bits

6.16 Electrical Characteristics: ADC

Typical values stated where $T_A = 25^\circ\text{C}$ and $V_{CC} = 14.4\text{ V}$, Min/Max values stated where $T_A = -40^\circ\text{C}$ to 85°C and $V_{CC} = 2.2\text{ V}$ to 26 V (unless otherwise noted)

PARAMETER	TEST CONDITIONS	MIN	TYP	MAX	UNIT
Input voltage range	Internal reference (V_{REF1})	-0.2		1	V
	External reference (V_{REG})	-0.2		$0.8 \times V_{REG}$	
Full scale range	$V_{FS} = V_{REF1}$ or V_{REG}	$-V_{FS}$		V_{FS}	V
Integral nonlinearity ⁽¹⁾	16-bit, best fit, -0.1 V to $0.8 \times V_{REF1}$			± 6.6	LSB
	16-bit, best fit, -0.2 V to -0.1 V			± 13.1	
Offset error ⁽²⁾	16-bit, Post-calibration, $V_{FS} = V_{REF1}$		± 67	± 157	μV
Offset error drift	16-bit, Post-calibration, $V_{FS} = V_{REF1}$		0.6	3	$\mu\text{V}/^\circ\text{C}$
Gain error	16-bit, -0.1 V to $0.8 \times V_{FS}$		$\pm 0.2\%$	$\pm 0.8\%$	FSR
Gain error drift	16-bit, -0.1 V to $0.8 \times V_{FS}$			150	PPM/ $^\circ\text{C}$
Effective input resistance		8			$\text{M}\Omega$

(1) $1\text{ LSB} = V_{REF1}/(2^N) = 1.225/(2^{15}) = 37.4\ \mu\text{V}$ (when $t_{CONV} = 31.25\text{ ms}$)

(2) For VC1–VSS, VC2–VC1, VC3–VC2, VC4–VC3, VC4–VSS, PACK–VSS, and $V_{REF1}/2$, the offset error is multiplied by (1/ADC multiplexer scaling factor (K)).

6.17 Electrical Characteristics: ADC Digital Filter

Typical values stated where $T_A = 25^\circ\text{C}$ and $V_{CC} = 14.4\text{ V}$, Min/Max values stated where $T_A = -40^\circ\text{C}$ to 85°C and $V_{CC} = 2.2\text{ V}$ to 26 V (unless otherwise noted)

PARAMETER	TEST CONDITIONS	MIN	TYP	MAX	UNIT
Conversion time	Single conversion		31.25		ms
	Single conversion		15.63		
	Single conversion		7.81		
	Single conversion		1.95		
Resolution	No missing codes	16			Bits
Effective resolution	With sign, $t_{CONV} = 31.25\text{ ms}$	14	15		Bits
	With sign, $t_{CONV} = 15.63\text{ ms}$	13	14		
	With sign, $t_{CONV} = 7.81\text{ ms}$	11	12		
	With sign, $t_{CONV} = 1.95\text{ ms}$	9	10		

6.18 Electrical Characteristics: CHG, DSG FET Drive

Typical values stated where $T_A = 25^\circ\text{C}$ and $V_{CC} = 14.4\text{ V}$, Min/Max values stated where $T_A = -40^\circ\text{C}$ to 85°C and $V_{CC} = 2.2\text{ V}$ to 26 V (unless otherwise noted)

PARAMETER	TEST CONDITIONS	MIN	TYP	MAX	UNIT
Output voltage ratio	$\text{Ratio}_{DSG} = (V_{DSG} - V_{BAT})/V_{BAT}$, $2.2\text{ V} < V_{BAT} < 4.92\text{ V}$, $10\text{ M}\Omega$ between PACK and DSG	2.133	2.333	2.433	—
	$\text{Ratio}_{CHG} = (V_{CHG} - V_{BAT})/V_{BAT}$, $2.2\text{ V} < V_{BAT} < 4.92\text{ V}$, $10\text{ M}\Omega$ between BAT and CHG	2.133	2.333	2.433	
$V_{(FETON)}$	Output voltage, CHG and DSG on $V_{DSG(ON)} = V_{DSG} - V_{BAT}$, $4.92\text{ V} \leq V_{BAT} \leq 18\text{ V}$, $10\text{ M}\Omega$ between PACK and DSG	10.5	11.5	12	V
	$V_{CHG(ON)} = V_{CHG} - V_{BAT}$, $4.92\text{ V} \leq V_{BAT} \leq 18\text{ V}$, $10\text{ M}\Omega$ between BAT and CHG	10.5	11.5	12	
$V_{(FETOFF)}$	Output voltage, CHG and DSG off $V_{DSG(OFF)} = V_{DSG} - V_{PACK}$, $10\text{ M}\Omega$ between PACK and DSG	-0.4		0.4	V
	$V_{CHG(OFF)} = V_{CHG} - V_{BAT}$, $10\text{ M}\Omega$ between BAT and CHG	-0.4		0.4	
t_R	Rise time V_{DSG} from 0% to 35% $V_{DSG(ON)(TYP)}$, $V_{BAT} \geq 2.2\text{ V}$, $C_L = 4.7\text{ nF}$ between DSG and PACK, $5.1\text{ k}\Omega$ between DSG and C_L , $10\text{ M}\Omega$ between PACK and DSG		200	500	μs
	V_{CHG} from 0% to 35% $V_{CHG(ON)(TYP)}$, $V_{BAT} \geq 2.2\text{ V}$, $C_L = 4.7\text{ nF}$ between CHG and BAT, $5.1\text{ k}\Omega$ between CHG and C_L , $10\text{ M}\Omega$ between BAT and CHG		200	500	

Electrical Characteristics: CHG, DSG FET Drive (continued)

Typical values stated where $T_A = 25^\circ\text{C}$ and $V_{CC} = 14.4\text{ V}$, Min/Max values stated where $T_A = -40^\circ\text{C}$ to 85°C and $V_{CC} = 2.2\text{ V}$ to 26 V (unless otherwise noted)

PARAMETER	TEST CONDITIONS	MIN	TYP	MAX	UNIT
t_F Fall time	V_{DSG} from $V_{DSG(ON)(TYP)}$ to 1 V , $V_{BAT} \geq 2.2\text{ V}$, $C_L = 4.7\text{ nF}$ between DSG and PACK, $5.1\text{ k}\Omega$ between DSG and C_L , $10\text{ M}\Omega$ between PACK and DSG		40	300	μs
	V_{CHG} from $V_{CHG(ON)(TYP)}$ to 1 V , $V_{BAT} \geq 2.2\text{ V}$, $C_L = 4.7\text{ nF}$ between CHG and BAT, $5.1\text{ k}\Omega$ between CHG and C_L , $10\text{ M}\Omega$ between BAT and CHG		40	200	

6.19 Electrical Characteristics: PCHG FET Drive

Typical values stated where $T_A = 25^\circ\text{C}$ and $V_{CC} = 14.4\text{ V}$, Min/Max values stated where $T_A = -40^\circ\text{C}$ to 85°C and $V_{CC} = 2.2\text{ V}$ to 26 V (unless otherwise noted)

PARAMETER	TEST CONDITIONS	MIN	TYP	MAX	UNIT
$V_{(FETON)}$ Output voltage, PCHG on	$V_{PCHG(ON)} = V_{V_{CC}} - V_{PCHG}$, $10\text{ M}\Omega$ between V_{CC} and PCHG	6	7	8	V
$V_{(FETOFF)}$ Output voltage, PCHG off	$V_{PCHG(OFF)} = V_{V_{CC}} - V_{PCHG}$, $10\text{ M}\Omega$ between V_{CC} and PCHG	-0.4		0.4	V
t_R Rise time	V_{PCHG} from 10% to 90% $V_{PCHG(ON)(TYP)}$, $V_{V_{CC}} \geq 8\text{ V}$, $C_L = 4.7\text{ nF}$ between PCHG and V_{CC} , $5.1\text{ k}\Omega$ between PCHG and C_L , $10\text{ M}\Omega$ between V_{CC} and CHG		40	200	μs
t_F Fall time	V_{PCHG} from 90% to 10% $V_{PCHG(ON)(TYP)}$, $V_{V_{CC}} \geq 8\text{ V}$, $C_L = 4.7\text{ nF}$ between PCHG and V_{CC} , $5.1\text{ k}\Omega$ between PCHG and C_L , $10\text{ M}\Omega$ between V_{CC} and CHG		40	200	μs

6.20 Electrical Characteristics: FUSE Drive

Typical values stated where $T_A = 25^\circ\text{C}$ and $V_{CC} = 14.4\text{ V}$, Min/Max values stated where $T_A = -40^\circ\text{C}$ to 85°C and $V_{CC} = 2.2\text{ V}$ to 26 V (unless otherwise noted)

PARAMETER	TEST CONDITIONS	MIN	TYP	MAX	UNIT
V_{OH} Output voltage high	$V_{BAT} \geq 8\text{ V}$, $C_L = 1\text{ nF}$, $I_{AFEFUSE} = 0\text{ }\mu\text{A}$	6	7	8.65	V
	$V_{BAT} < 8\text{ V}$, $C_L = 1\text{ nF}$, $I_{AFEFUSE} = 0\text{ }\mu\text{A}$	$V_{BAT} - 0.1$		V_{BAT}	
V_{IH} High-level input		1.5	2.0	2.5	V
$I_{AFEFUSE(PU)}$ Internal pullup current	$V_{BAT} \geq 8\text{ V}$, $V_{AFEFUSE} = V_{SS}$		150	330	nA
$R_{AFEFUSE}$ Output impedance		2	2.6	3.2	k Ω
C_{IN} Input capacitance			5		pF
t_{DELAY} Fuse trip detection delay		128		256	μs
t_{RISE} Fuse output rise time	$V_{BAT} \geq 8\text{ V}$, $C_L = 1\text{ nF}$, $V_{OH} = 0\text{ V}$ to 5 V		5	20	μs

6.21 Electrical Characteristics: Internal Temperature Sensor

Typical values stated where $T_A = 25^\circ\text{C}$ and $V_{CC} = 14.4\text{ V}$, Min/Max values stated where $T_A = -40^\circ\text{C}$ to 85°C and $V_{CC} = 2.2\text{ V}$ to 26 V (unless otherwise noted)

PARAMETER	TEST CONDITIONS	MIN	TYP	MAX	UNIT
V_{TEMP} Internal temperature sensor voltage drift	V_{TEMP}	-1.9	-2.0	-2.1	mV/ $^\circ\text{C}$
	$V_{TEMP} - V_{TEMPN}$, assured by design	0.177	0.178	0.179	

6.22 Electrical Characteristics: TS1, TS2, TS3, TS4

Typical values stated where $T_A = 25^\circ\text{C}$ and $V_{CC} = 14.4\text{ V}$, Min/Max values stated where $T_A = -40^\circ\text{C}$ to 85°C and $V_{CC} = 2.2\text{ V}$ to 26 V (unless otherwise noted)

PARAMETER		TEST CONDITIONS	MIN	TYP	MAX	UNIT
V_{IN}	Input voltage range	TS1, TS2, TS3, TS4, $V_{BIAS} = V_{REF1}$	-0.2	$0.8 \times V_{REF1}$		V
		TS1, TS2, TS3, TS4, $V_{BIAS} = V_{REG}$	-0.2	$0.8 \times V_{REG}$		
$R_{NTC(PU)}$	Internal pullup resistance	TS1, TS2, TS3, TS4	14.4	18	21.6	k Ω
$R_{NTC(DRIFT)}$	Resistance drift over temperature	TS1, TS2, TS3, TS4	-360	-280	-200	PPM/ $^\circ\text{C}$

6.23 Electrical Characteristics: PTC, PTCEN

Typical values stated where $T_A = 25^\circ\text{C}$ and $V_{CC} = 14.4\text{ V}$, Min/Max values stated where $T_A = -40^\circ\text{C}$ to 85°C and $V_{CC} = 2.2\text{ V}$ to 26 V (unless otherwise noted)

PARAMETER		TEST CONDITIONS	MIN	TYP	MAX	UNIT
$R_{PTC(TRIP)}$	PTC trip resistance		1.2	2.5	3.95	M Ω
$V_{PTC(TRIP)}$	PTC trip voltage	$V_{PTC(TRIP)} = V_{PTCEN} - V_{PTC}$	200	500	890	mV
I_{PTC}	Internal PTC current bias	$T_A = -40^\circ\text{C}$ to 110°C	200	290	350	nA
$t_{PTC(Delay)}$	PTC delay time	$T_A = -40^\circ\text{C}$ to 110°C	40	80	145	ms

6.24 Electrical Characteristics: Internal 1.8-V LDO

Typical values stated where $T_A = 25^\circ\text{C}$ and $V_{CC} = 14.4\text{ V}$, Min/Max values stated where $T_A = -40^\circ\text{C}$ to 85°C and $V_{CC} = 2.2\text{ V}$ to 26 V (unless otherwise noted)

PARAMETER		TEST CONDITIONS	MIN	TYP	MAX	UNIT
V_{REG}	Regulator voltage		1.6	1.8	2.0	V
$\Delta V_{O(TEMP)}$	Regulator output over temperature	$\Delta V_{REG}/\Delta T_A$, $I_{REG} = 10\text{ mA}$		$\pm 0.25\%$		
$\Delta V_{O(LINE)}$	Line regulation	$\Delta V_{REG}/\Delta V_{BAT}$, $V_{BAT} = 10\text{ mA}$	-0.6%		0.5%	
$\Delta V_{O(LOAD)}$	Load regulation	$\Delta V_{REG}/\Delta I_{REG}$, $I_{REG} = 0\text{ mA}$ to 10 mA	-1.5%		1.5%	
I_{REG}	Regulator output current limit	$V_{REG} = 0.9 \times V_{REG(NOM)}$, $V_{IN} > 2.2\text{ V}$	20			mA
I_{SC}	Regulator short-circuit current limit	$V_{REG} = 0 \times V_{REG(NOM)}$	25	40	55	mA
$PSRR_{REG}$	Power supply rejection ratio	$\Delta V_{BAT}/\Delta V_{REG}$, $I_{REG} = 10\text{ mA}$, $V_{IN} > 2.5\text{ V}$, $f = 10\text{ Hz}$		40		dB
V_{SLEW}	Slew rate enhancement voltage threshold	V_{REG}	1.58	1.65		V

6.25 Electrical Characteristics: High-Frequency Oscillator

Typical values stated where $T_A = 25^\circ\text{C}$ and $V_{CC} = 14.4\text{ V}$, Min/Max values stated where $T_A = -40^\circ\text{C}$ to 85°C and $V_{CC} = 2.2\text{ V}$ to 26 V (unless otherwise noted)

PARAMETER		TEST CONDITIONS	MIN	TYP	MAX	UNIT
f_{HFO}	Operating frequency			16.78		MHz
$f_{HFO(ERR)}$	Frequency error	$T_A = -20^\circ\text{C}$ to 70°C , includes frequency drift	-2.5%	$\pm 0.25\%$	2.5%	
		$T_A = -40^\circ\text{C}$ to 85°C , includes frequency drift	-3.5%	$\pm 0.25\%$	3.5%	
$t_{HFO(SU)}$	Start-up time	$T_A = -20^\circ\text{C}$ to 85°C , oscillator frequency within $\pm 3\%$ of nominal			4	ms
		oscillator frequency within $\pm 3\%$ of nominal			100	μs

6.26 Electrical Characteristics: Low-Frequency Oscillator

Typical values stated where $T_A = 25^\circ\text{C}$ and $V_{CC} = 14.4\text{ V}$, Min/Max values stated where $T_A = -40^\circ\text{C}$ to 85°C and $V_{CC} = 2.2\text{ V}$ to 26 V (unless otherwise noted)

PARAMETER	TEST CONDITIONS	MIN	TYP	MAX	UNIT
f_{LFO} Operating frequency			262.144		kHz
$f_{LFO(ERR)}$ Frequency error	$T_A = -20^\circ\text{C}$ to 70°C , includes frequency drift	-1.5%	$\pm 0.25\%$	1.5%	
	$T_A = -40^\circ\text{C}$ to 85°C , includes frequency drift	-2.5	± 0.25	2.5	
$f_{LFO(FAIL)}$ Failure detection frequency		30	80	100	kHz

6.27 Electrical Characteristics: Voltage Reference 1

Typical values stated where $T_A = 25^\circ\text{C}$ and $V_{CC} = 14.4\text{ V}$, Min/Max values stated where $T_A = -40^\circ\text{C}$ to 85°C and $V_{CC} = 2.2\text{ V}$ to 26 V (unless otherwise noted)

PARAMETER	TEST CONDITIONS	MIN	TYP	MAX	UNIT
V_{REF1} Internal reference voltage	$T_A = 25^\circ\text{C}$, after trim	1.21	1.215	1.22	V
$V_{REF1(DRIFT)}$ Internal reference voltage drift	$T_A = 0^\circ\text{C}$ to 60°C , after trim		± 50		PPM/ $^\circ\text{C}$
	$T_A = -40^\circ\text{C}$ to 85°C , after trim		± 80		

6.28 Electrical Characteristics: Voltage Reference 2

Typical values stated where $T_A = 25^\circ\text{C}$ and $V_{CC} = 14.4\text{ V}$, Min/Max values stated where $T_A = -40^\circ\text{C}$ to 85°C and $V_{CC} = 2.2\text{ V}$ to 26 V (unless otherwise noted)

PARAMETER	TEST CONDITIONS	MIN	TYP	MAX	UNIT
V_{REF2} Internal reference voltage	$T_A = 25^\circ\text{C}$, after trim	1.22	1.225	1.23	V
$V_{REF2(DRIFT)}$ Internal reference voltage drift	$T_A = 0^\circ\text{C}$ to 60°C , after trim		± 50		PPM/ $^\circ\text{C}$
	$T_A = -40^\circ\text{C}$ to 85°C , after trim		± 80		

6.29 Electrical Characteristics: Instruction Flash

Typical values stated where $T_A = 25^\circ\text{C}$ and $V_{CC} = 14.4\text{ V}$, Min/Max values stated where $T_A = -40^\circ\text{C}$ to 85°C and $V_{CC} = 2.2\text{ V}$ to 26 V (unless otherwise noted)

PARAMETER	TEST CONDITIONS	MIN	TYP	MAX	UNIT
Data retention		10			Years
Flash programming write cycles		1000			Cycles
$t_{PROGWORD}$ Word programming time	$T_A = -40^\circ\text{C}$ to 85°C			40	μs
$t_{MASSERASE}$ Mass-erase time	$T_A = -40^\circ\text{C}$ to 85°C			40	ms
$t_{PAGEERASE}$ Page-erase time	$T_A = -40^\circ\text{C}$ to 85°C			40	ms
$I_{FLASHREAD}$ Flash-read current	$T_A = -40^\circ\text{C}$ to 85°C			2	mA
$I_{FLASHWRITE}$ Flash-write current	$T_A = -40^\circ\text{C}$ to 85°C			5	mA
$I_{FLASHERASE}$ Flash-erase current	$T_A = -40^\circ\text{C}$ to 85°C			15	mA

6.30 Electrical Characteristics: Data Flash

Typical values stated where $T_A = 25^\circ\text{C}$ and $V_{CC} = 14.4\text{ V}$, Min/Max values stated where $T_A = -40^\circ\text{C}$ to 85°C and $V_{CC} = 2.2\text{ V}$ to 26 V (unless otherwise noted)

PARAMETER	TEST CONDITIONS	MIN	TYP	MAX	UNIT
Data retention		10			Years
Flash programming write cycles		20000			Cycles
$t_{PROGWORD}$ Word programming time	$T_A = -40^\circ\text{C}$ to 85°C			40	μs

Electrical Characteristics: Data Flash (continued)

Typical values stated where $T_A = 25^\circ\text{C}$ and $V_{CC} = 14.4\text{ V}$, Min/Max values stated where $T_A = -40^\circ\text{C}$ to 85°C and $V_{CC} = 2.2\text{ V}$ to 26 V (unless otherwise noted)

PARAMETER	TEST CONDITIONS	MIN	TYP	MAX	UNIT
$t_{\text{MASSERASE}}$	Mass-erase time $T_A = -40^\circ\text{C}$ to 85°C			40	ms
$t_{\text{PAGEERASE}}$	Page-erase time $T_A = -40^\circ\text{C}$ to 85°C			40	ms
$I_{\text{FLASHREAD}}$	Flash-read current $T_A = -40^\circ\text{C}$ to 85°C			1	mA
$I_{\text{FLASHWRITE}}$	Flash-write current $T_A = -40^\circ\text{C}$ to 85°C			5	mA
$I_{\text{FLASHERASE}}$	Flash-erase current $T_A = -40^\circ\text{C}$ to 85°C			15	mA

6.31 Electrical Characteristics: OCD, SCC, SCD1, SCD2 Current Protection Thresholds

Typical values stated where $T_A = 25^\circ\text{C}$ and $V_{CC} = 14.4\text{ V}$, Min/Max values stated where $T_A = -40^\circ\text{C}$ to 85°C and $V_{CC} = 2.2\text{ V}$ to 26 V (unless otherwise noted)

PARAMETER	TEST CONDITIONS	MIN	TYP	MAX	UNIT
V_{OCD}	OCD detection threshold voltage range $V_{\text{OCD}} = V_{\text{SRP}} - V_{\text{SRN}}$, AFE PROTECTION CONTROL[RSNS] = 1	-16.6		-100	mV
	$V_{\text{OCD}} = V_{\text{SRP}} - V_{\text{SRN}}$, AFE PROTECTION CONTROL[RSNS] = 0	-8.3		-50	
ΔV_{OCD}	OCD detection threshold voltage program step $V_{\text{OCD}} = V_{\text{SRP}} - V_{\text{SRN}}$, AFE PROTECTION CONTROL[RSNS] = 1		-5.56		mV
	$V_{\text{OCD}} = V_{\text{SRP}} - V_{\text{SRN}}$, AFE PROTECTION CONTROL[RSNS] = 0		-2.78		
V_{SCC}	SCC detection threshold voltage range $V_{\text{SCC}} = V_{\text{SRP}} - V_{\text{SRN}}$, AFE PROTECTION CONTROL[RSNS] = 1	44.4		200	mV
	$V_{\text{SCC}} = V_{\text{SRP}} - V_{\text{SRN}}$, AFE PROTECTION CONTROL[RSNS] = 0	22.2		100	
ΔV_{SCC}	SCC detection threshold voltage program step $V_{\text{SCC}} = V_{\text{SRP}} - V_{\text{SRN}}$, AFE PROTECTION CONTROL[RSNS] = 1		22.2		mV
	$V_{\text{SCC}} = V_{\text{SRP}} - V_{\text{SRN}}$, AFE PROTECTION CONTROL[RSNS] = 0		11.1		
V_{SCD1}	SCD1 detection threshold voltage range $V_{\text{SCD1}} = V_{\text{SRP}} - V_{\text{SRN}}$, AFE PROTECTION CONTROL[RSNS] = 1	-44.4		-200	mV
	$V_{\text{SCD1}} = V_{\text{SRP}} - V_{\text{SRN}}$, AFE PROTECTION CONTROL[RSNS] = 0	-22.2		-100	
ΔV_{SCD1}	SCD1 detection threshold voltage program step $V_{\text{SCD1}} = V_{\text{SRP}} - V_{\text{SRN}}$, AFE PROTECTION CONTROL[RSNS] = 1		-22.2		mV
	$V_{\text{SCD1}} = V_{\text{SRP}} - V_{\text{SRN}}$, AFE PROTECTION CONTROL[RSNS] = 0		-11.1		
V_{SCD2}	SCD2 detection threshold voltage range $V_{\text{SCD2}} = V_{\text{SRP}} - V_{\text{SRN}}$, AFE PROTECTION CONTROL[RSNS] = 1	-44.4		-200	mV
	$V_{\text{SCD2}} = V_{\text{SRP}} - V_{\text{SRN}}$, AFE PROTECTION CONTROL[RSNS] = 0	-22.2		-100	
ΔV_{SCD2}	SCD2 detection threshold voltage program step $V_{\text{SCD2}} = V_{\text{SRP}} - V_{\text{SRN}}$, AFE PROTECTION CONTROL[RSNS] = 1		-22.2		mV
	$V_{\text{SCD2}} = V_{\text{SRP}} - V_{\text{SRN}}$, AFE PROTECTION CONTROL[RSNS] = 0		-11.1		
V_{OFFSET}	OCD, SCC, and SCDx offset error Post-trim	-2.5		2.5	mV
V_{SCALE}	OCD, SCC, and SCDx scale error No trim	-10%		10%	
	Post-trim	-5%		5%	

6.32 Timing Requirements: OCD, SCC, SCD1, SCD2 Current Protection Timing

Typical values stated where $T_A = 25^\circ\text{C}$ and $V_{CC} = 14.4\text{ V}$, Min/Max values stated where $T_A = -40^\circ\text{C}$ to 85°C and $V_{CC} = 2.2\text{ V}$ to 26 V (unless otherwise noted)

			MIN	NOM	MAX	UNIT
t_{OCD}	OCD detection delay time		1		31	ms
Δt_{OCD}	OCD detection delay time program step			2		ms
t_{SCC}	SCC detection delay time		0		915	μs
Δt_{SCC}	SCC detection delay time program step			61		μs
t_{SCD1}	SCD1 detection delay time	AFE PROTECTION CONTROL[SCDDx2] = 0	0		915	μs
		AFE PROTECTION CONTROL[SCDDx2] = 1	0		1850	
Δt_{SCD1}	SCD1 detection delay time program step	AFE PROTECTION CONTROL[SCDDx2] = 0		61		μs
		AFE PROTECTION CONTROL[SCDDx2] = 1		121		
t_{SCD2}	SCD2 detection delay time	AFE PROTECTION CONTROL[SCDDx2] = 0	0		458	μs
		AFE PROTECTION CONTROL[SCDDx2] = 1	0		915	
Δt_{SCD2}	SCD2 detection delay time program step	AFE PROTECTION CONTROL[SCDDx2] = 0		30.5		μs
		AFE PROTECTION CONTROL[SCDDx2] = 1		61		
t_{DETECT}	Current fault detect time	$V_{\text{SRP}} - V_{\text{SRN}} = V_T - 3\text{ mV}$ for OCD, SCD1, and SC2, $V_{\text{SRP}} - V_{\text{SRN}} = V_T + 3\text{ mV}$ for SCC			160	μs
t_{ACC}	Current fault delay time accuracy	Max delay setting	-10%		10%	

6.33 Timing Requirements: SMBus

Typical values stated where $T_A = 25^\circ\text{C}$ and $V_{CC} = 14.4\text{ V}$, Min/Max values stated where $T_A = -40^\circ\text{C}$ to 85°C and $V_{CC} = 2.2\text{ V}$ to 26 V (unless otherwise noted)

			MIN	NOM	MAX	UNIT
f_{SMB}	SMBus operating frequency	SLAVE mode, SMBC 50% duty cycle	10		100	kHz
f_{MAS}	SMBus master clock frequency	MASTER mode, no clock low slave extend		51.2		kHz
t_{BUF}	Bus free time between start and stop		4.7			μs
$t_{\text{HD(START)}}$	Hold time after (repeated) start		4.0			μs
$t_{\text{SU(START)}}$	Repeated start setup time		4.7			μs
$t_{\text{SU(STOP)}}$	Stop setup time		4.0			μs
$t_{\text{HD(DATA)}}$	Data hold time		300			ns
$t_{\text{SU(DATA)}}$	Data setup time		250			ns
t_{TIMEOUT}	Error signal detect time		25		35	ms
t_{LOW}	Clock low period		4.7			μs
t_{HIGH}	Clock high period		4.0		50	μs
t_{R}	Clock rise time	10% to 90%			1000	ns
t_{F}	Clock fall time	90% to 10%			300	ns
$t_{\text{LOW(SEXT)}}$	Cumulative clock low slave extend time				25	ms
$t_{\text{LOW(MEXT)}}$	Cumulative clock low master extend time				10	ms

6.34 Timing Requirements: SMBus XL

Typical values stated where $T_A = 25^\circ\text{C}$ and $V_{CC} = 14.4\text{ V}$, Min/Max values stated where $T_A = -40^\circ\text{C}$ to 85°C and $V_{CC} = 2.2\text{ V}$ to 26 V (unless otherwise noted)

			MIN	NOM	MAX	UNIT
f_{SMBXL}	SMBus XL operating frequency	SLAVE mode	40		400	kHz
t_{BUF}	Bus free time between start and stop		4.7			μs
$t_{\text{HD(START)}}$	Hold time after (repeated) start		4.0			μs
$t_{\text{SU(START)}}$	Repeated start setup time		4.7			μs
$t_{\text{SU(STOP)}}$	Stop setup time		4.0			μs
t_{TIMEOUT}	Error signal detect time		5		20	ms
t_{LOW}	Clock low period				20	μs
t_{HIGH}	Clock high period				20	μs

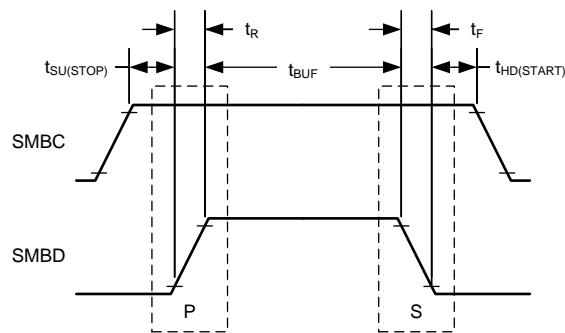

Start and Stop Condition

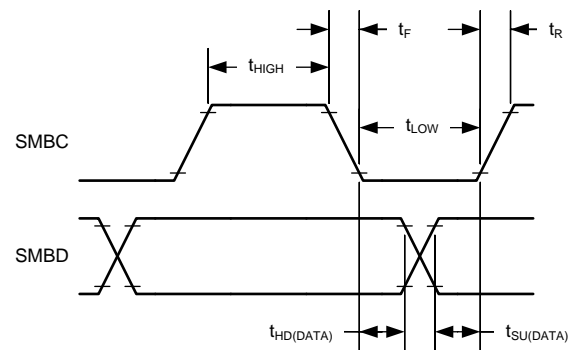

Wait and Hold Condition

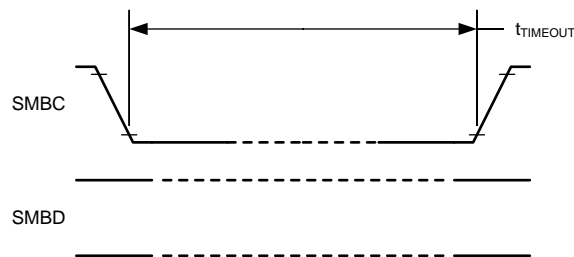

Timeout Condition

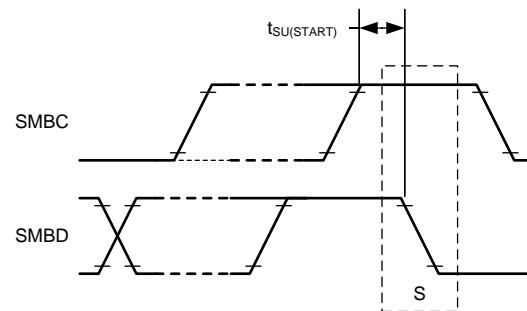

Repeated Start Condition

Figure 4. SMBus Timing Diagram

6.35 Typical Characteristics

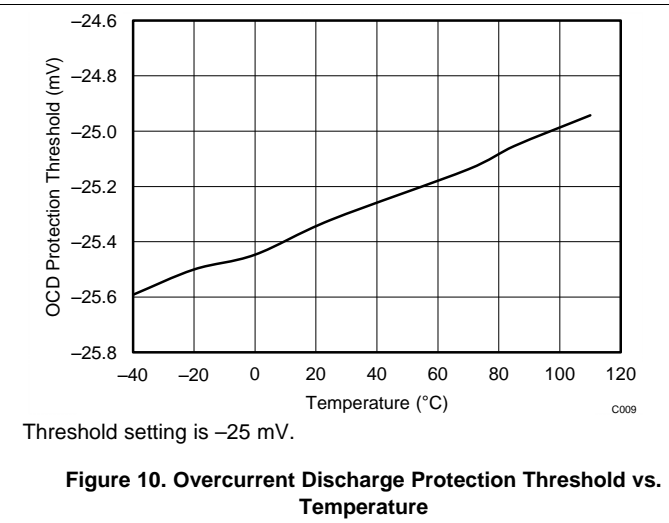
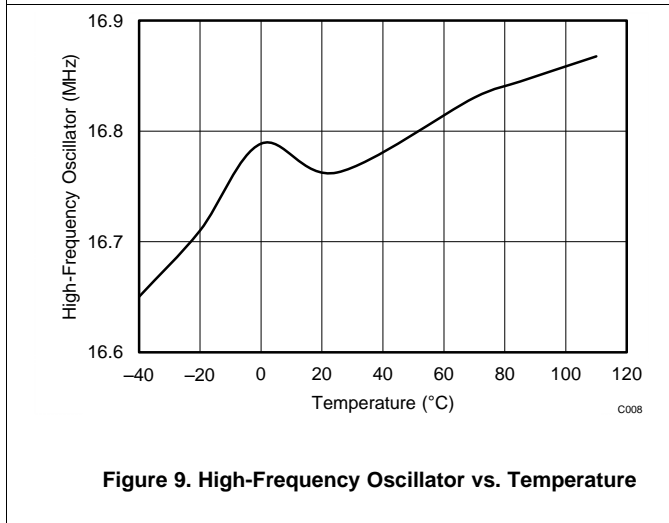
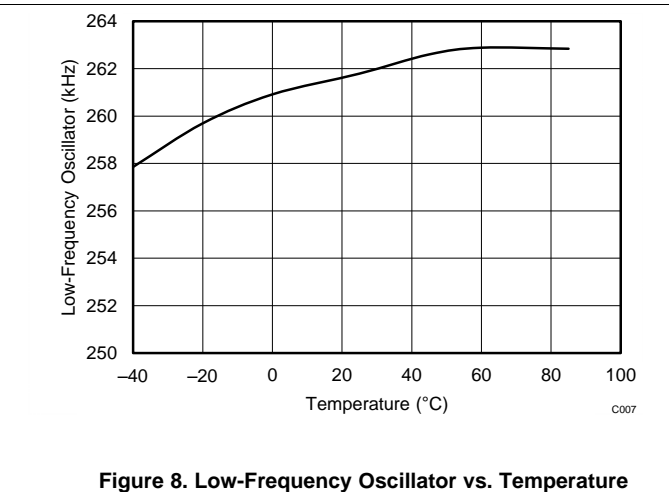
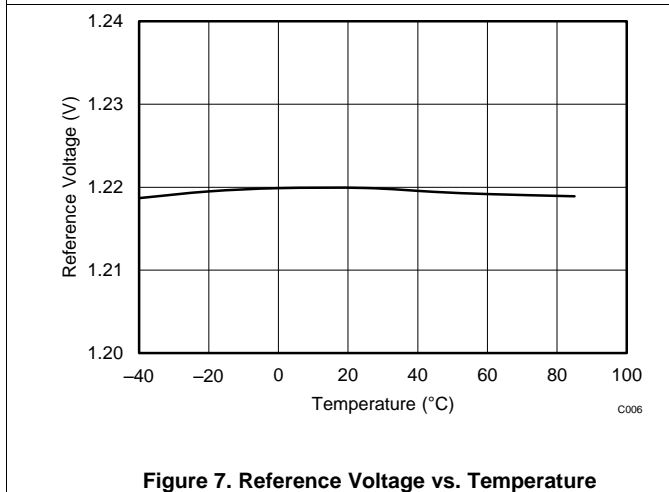
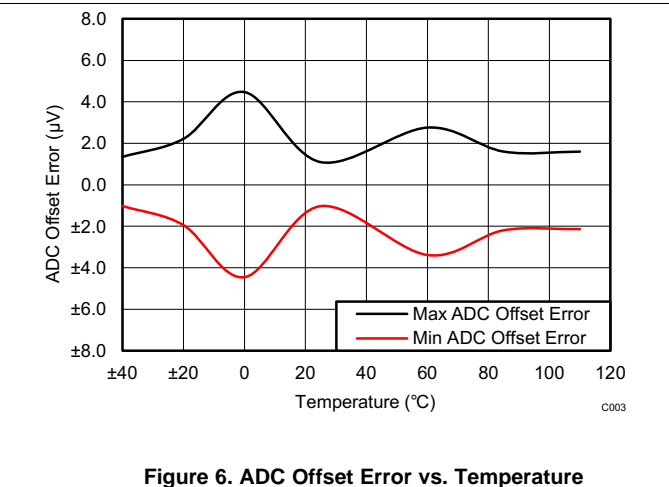
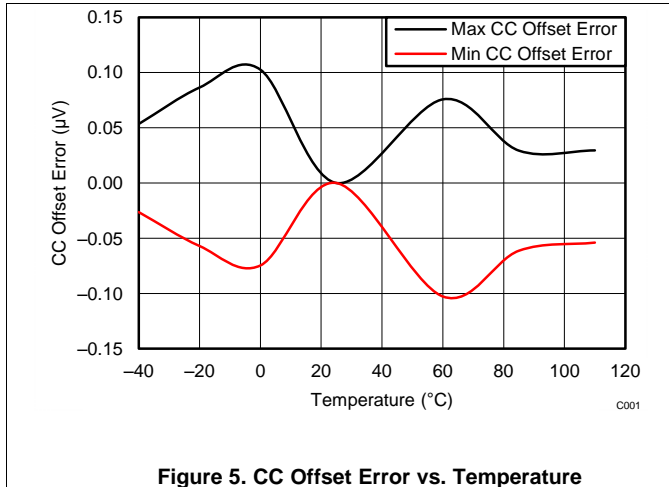

Typical Characteristics (continued)

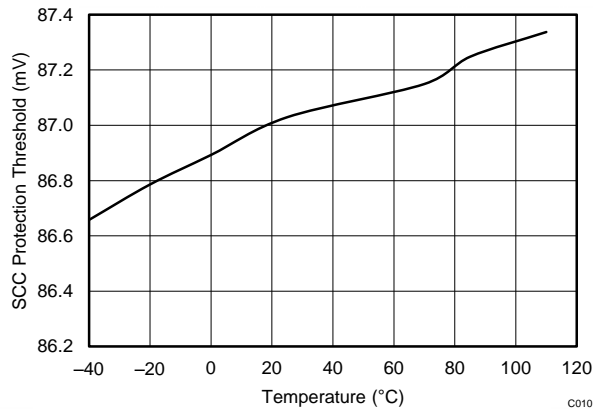

Threshold setting is 88.85 mV.

Figure 11. Short Circuit Charge Protection Threshold vs. Temperature

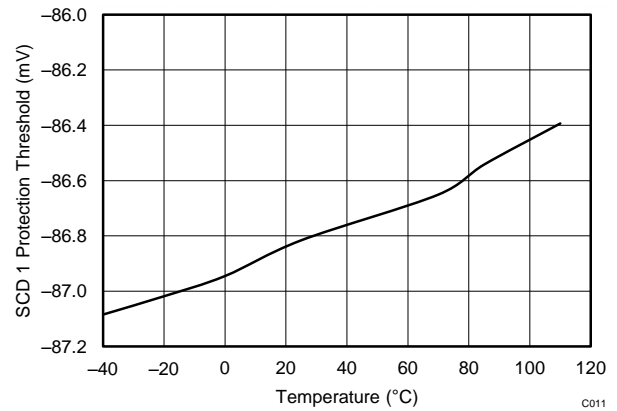

Threshold setting is -88.85 mV.

Figure 12. Short Circuit Discharge 1 Protection Threshold vs. Temperature

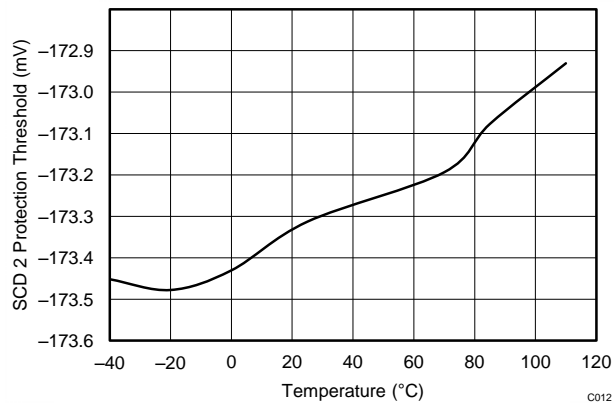

Threshold setting is -177.7 mV.

Figure 13. Short Circuit Discharge 2 Protection Threshold vs. Temperature

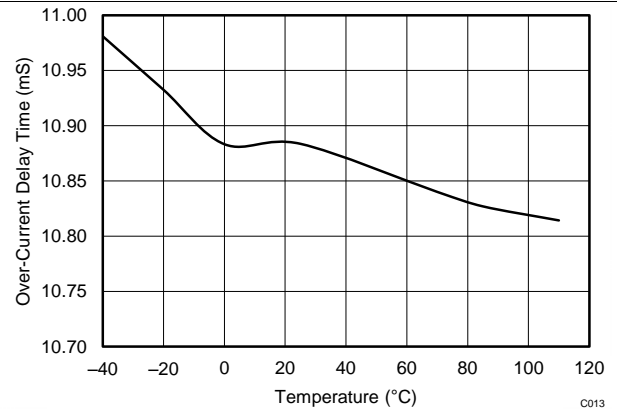

Threshold setting is 11 ms.

Figure 14. Overcurrent Delay Time vs. Temperature

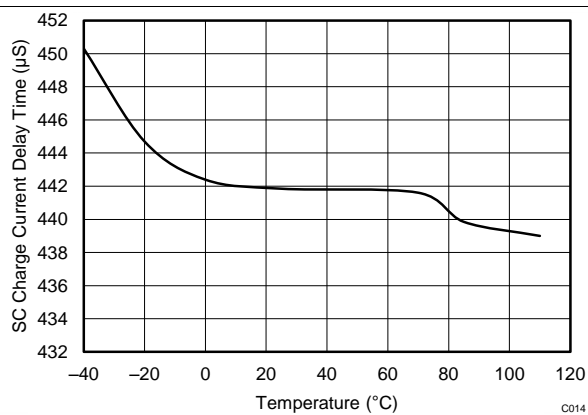

Threshold setting is 465 µs.

Figure 15. Short Circuit Charge Current Delay Time vs. Temperature

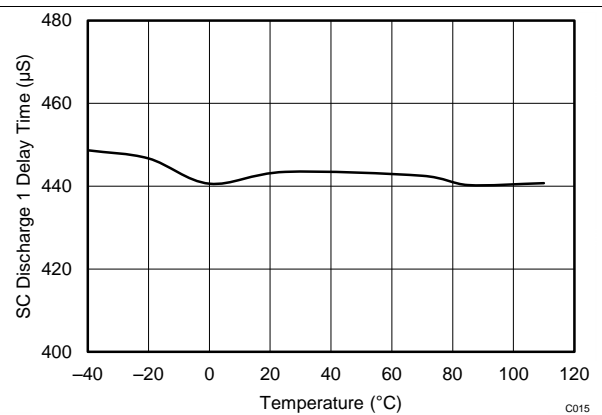

Threshold setting is 465 µs (including internal delay).

Figure 16. Short Circuit Discharge 1 Delay Time vs. Temperature

Typical Characteristics (continued)

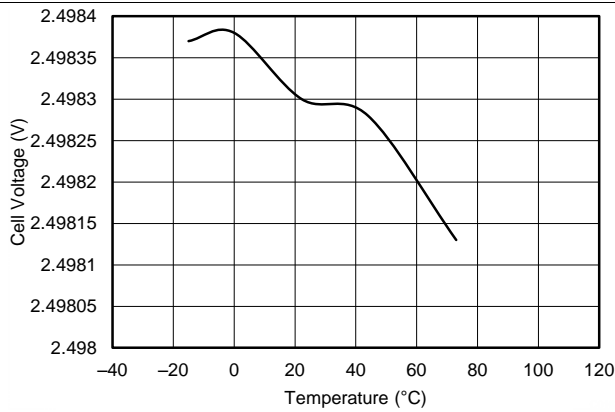
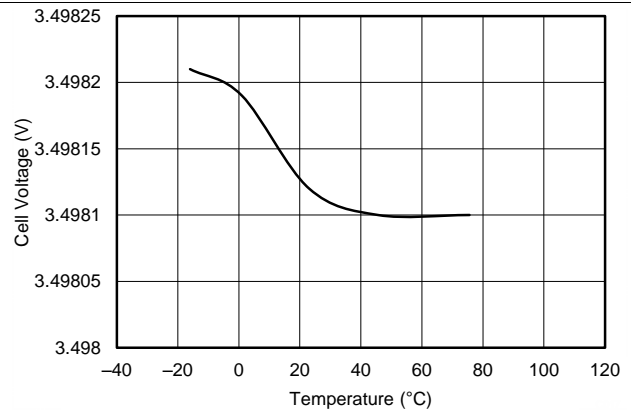
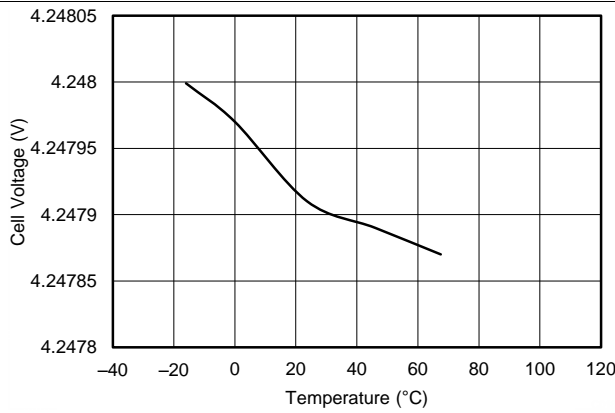

Figure 17. V_{CELL} Measurement at 2.5-V vs. Temperature



This is the V_{CELL} average for single cell.

Figure 18. V_{CELL} Measurement at 3.5-V vs. Temperature



This is the V_{CELL} average for single cell.

Figure 19. V_{CELL} Measurement at 4.25-V vs. Temperature

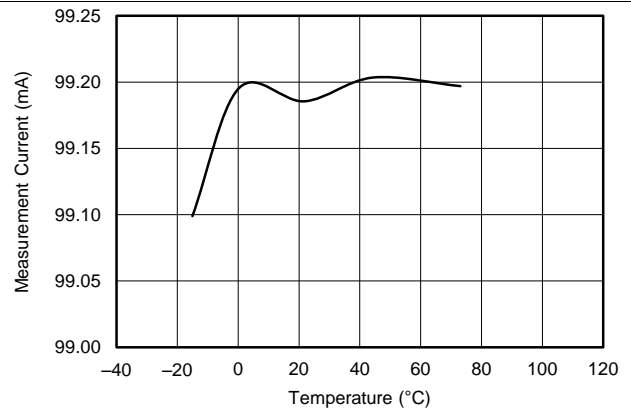

$I_{SET} = 100 \text{ mA}$

Figure 20. I Measured vs. Temperature

7 Detailed Description

7.1 Overview

The bq4050 device, incorporating Compensated End-of-Discharge Voltage (CEDV) technology, provides cell balancing while charging or at rest. This fully integrated, single-chip, pack-based solution, including a diagnostic lifetime data monitor and black box recorder, provides a rich array of features for gas gauging, protection, and authentication for 1-series, 2-series, 3-series, and 4-series cell Li-Ion and Li-Polymer battery packs.

7.2 Functional Block Diagram

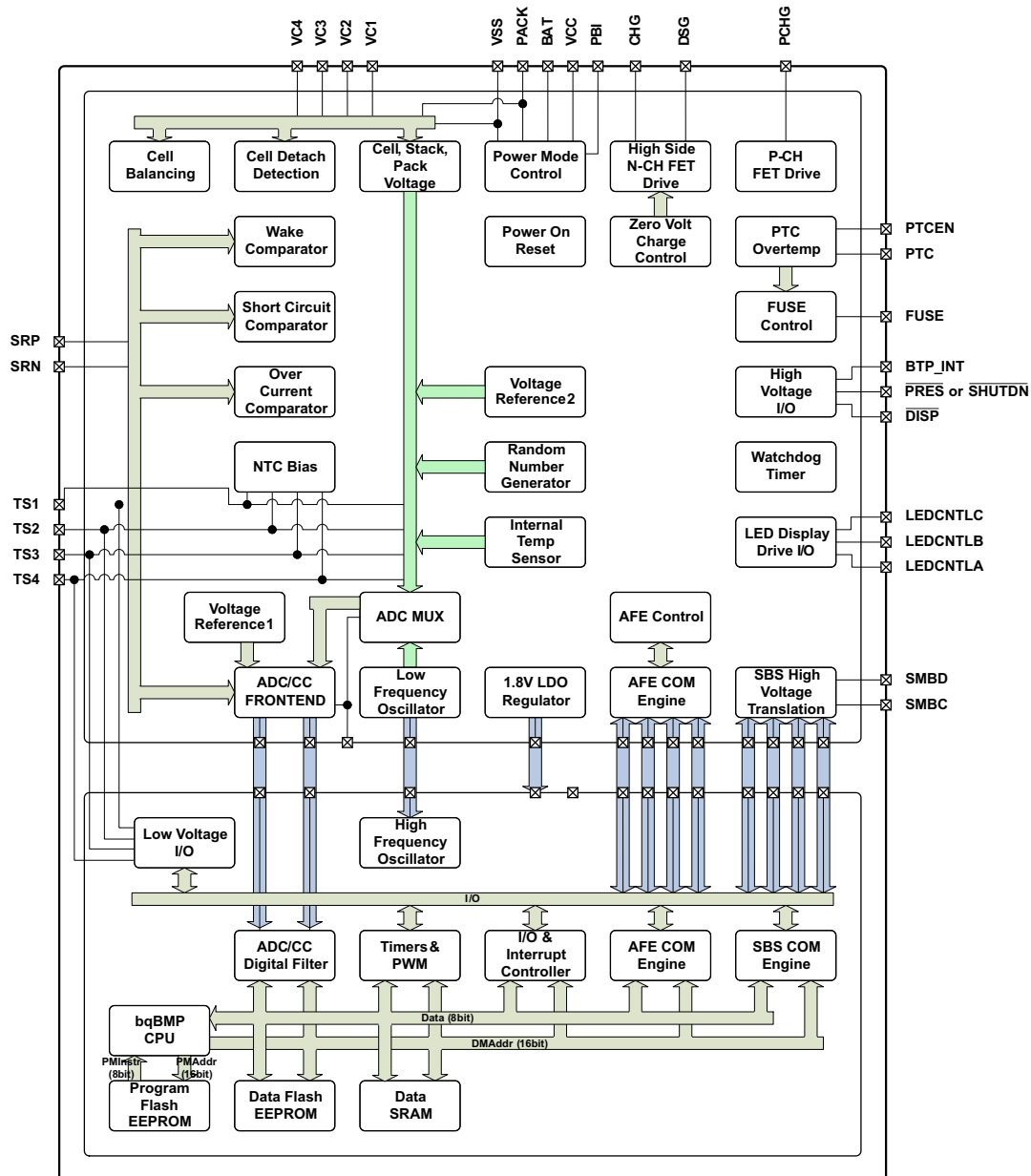

Copyright © 2017, Texas Instruments Incorporated

7.3 Feature Description

7.3.1 Primary (1st Level) Safety Features

The bq4050 gas gauge supports a wide range of battery and system protection features that can easily be configured. See the *bq4050 Technical Reference Manual* ([SLUUAQ3](#)) for detailed descriptions of each protection function.

The primary safety features include:

- Cell Overvoltage Protection
- Cell Undervoltage Protection
- Overcurrent in Charge Protection
- Overcurrent in Discharge Protection
- Overload in Discharge Protection
- Short Circuit in Charge Protection
- Short Circuit in Discharge Protection
- Overtemperature in Charge Protection
- Overtemperature in Discharge Protection
- Undertemperature in Charge Protection
- Undertemperature in Discharge Protection
- Overtemperature FET protection
- Precharge Timeout Protection
- Host Watchdog Timeout Protection
- Overcharge Protection
- Overcharging Voltage Protection
- Overcharging Current Protection
- Over Precharge Current Protection

7.3.2 Secondary (2nd Level) Safety Features

The secondary safety features of the bq4050 gas gauge can be used to indicate more serious faults via the FUSE pin. This pin can be used to blow an in-line fuse to permanently disable the battery pack from charging or discharging. See the *bq4050 Technical Reference Manual* ([SLUUAQ3](#)) for detailed descriptions of each protection function.

The secondary safety features provide protection against:

- Safety Overvoltage Permanent Failure
- Safety Undervoltage Permanent Failure
- Safety Overtemperature Permanent Failure
- Safety FET Overtemperature Permanent Failure
- Fuse Failure Permanent Failure
- PTC Permanent Failure
- Voltage Imbalance at Rest (VIMR) Permanent Failure
- Voltage Imbalance Active (VIMA) Permanent Failure
- Charge FET Permanent Failure
- Discharge FET Permanent Failure
- AFE Register Permanent Failure
- AFE Communication Permanent Failure
- Second Level Protector Permanent Failure
- Instruction Flash Checksum Permanent Failure
- Open Cell Connection Permanent Failure
- Data Flash Permanent Failure
- Open Thermistor Permanent Failure

Feature Description (continued)

7.3.3 Charge Control Features

The bq4050 gas gauge charge control features include:

- Supports JEITA temperature ranges. Reports charging voltage and charging current according to the active temperature range
- Handles more complex charging profiles. Allows for splitting the standard temperature range into two subranges and allows for varying the charging current according to the cell voltage
- Reports the appropriate charging current needed for constant current charging and the appropriate charging voltage needed for constant voltage charging to a smart charger using SMBus broadcasts
- Reduces the charge difference of the battery cells in fully charged state of the battery pack gradually using a voltage-based cell balancing algorithm during charging. A voltage threshold can be set up for cell balancing to be active. This prevents fully charged cells from overcharging and causing excessive degradation and also increases the usable pack energy by preventing premature charge termination.
- Supports precharging/0-volt charging
- Supports charge inhibit and charge suspend if the battery pack temperature is out of temperature range
- Reports charging fault and also indicates charge status via charge and discharge alarms

7.3.4 Gas Gauging

The bq4050 gas gauge uses the Compensated End-of-Discharge Voltage (CEDV) algorithm to measure and calculate the available capacity in battery cells. The bq4050 device accumulates a measure of charge and discharge currents, estimates self-discharge of the battery, and adjusts the self-discharge estimation based on temperature. See the *bq4050 Technical Reference Manual (SLUUAQ3)* for further details.

7.3.5 Configuration

7.3.5.1 Oscillator Function

The bq4050 gas gauge fully integrates the system oscillators and does not require any external components to support this feature.

7.3.5.2 System Present Operation

The bq4050 gas gauge checks the $\overline{\text{PRES}}$ pin periodically (1 s). If $\overline{\text{PRES}}$ input is pulled to ground by the external system, the bq4050 device detects this as system present.

7.3.5.3 Emergency Shutdown

For battery maintenance, the emergency shutdown feature enables a push button action connecting the SHUTDOWN pin to shut down an embedded battery pack system before removing the battery. A high-to-low transition of the SHUTDOWN pin signals the bq4050 gas gauge to turn off the CHG and DSG FETs, disconnecting the power from the system to safely remove the battery pack. The CHG and DSG FETs can be turned on again by another high-to-low transition detected by the SHUTDOWN pin or when a data flash configurable timeout is reached.

7.3.5.4 1-Series, 2-Series, 3-Series, or 4-Series Cell Configuration

In a 1-series cell configuration, VC4 is shorted to VC, VC2, and VC1. In a 2-series cell configuration, VC4 is shorted to VC3 and VC2. In a 3-series cell configuration, VC4 is shorted to VC3.

7.3.5.5 Cell Balancing

The device reduces the charge difference of the battery cells in a fully charged state of the battery pack by gradually using a voltage-based cell balancing algorithm during charging. A voltage threshold can be set up for cell balancing to be active. This prevents fully charged cells from overcharging and causing excessive degradation, and increases the usable pack energy by preventing premature charge termination.

Feature Description (continued)

7.3.6 Battery Parameter Measurements

7.3.6.1 Charge and Discharge Counting

The bq4050 gas gauge uses an integrating delta-sigma analog-to-digital converter (ADC) for current measurement, and a second delta-sigma ADC for individual cell and battery voltage and temperature measurement.

The integrating delta-sigma ADC measures the charge/discharge flow of the battery by measuring the voltage drop across a small-value sense resistor between the SRP and SRN terminals. The integrating ADC measures bipolar signals from -0.1 V to 0.1 V . The bq4050 gauge detects charge activity when $V_{SR} = V_{(SRP)} - V_{(SRN)}$ is positive, and discharge activity when $V_{SR} = V_{(SRP)} - V_{(SRN)}$ is negative. The bq4050 gas gauge continuously integrates the signal over time, using an internal counter. The fundamental rate of the counter is 0.26 nVh.

7.3.7 Battery Trip Point (BTP)

Required for WIN8 OS, the battery trip point (BTP) feature indicates when the RSOC of a battery pack has depleted to a certain value set in a DF register. This feature enables a host to program two capacity-based thresholds that govern the triggering of a BTP interrupt on the BTP_INT pin and the setting or clearing of the *OperationStatus[BTP_INT]* on the basis of *RemainingCapacity()*.

An internal weak pullup is applied when the BTP feature is active. Depending on the system design, an external pullup may be required to put on the BTP_INT pin. See [Electrical Characteristics: PRES, BTP_INT, DISP](#) for details.

7.3.8 Lifetime Data Logging Features

The bq4050 gas gauge offers lifetime data logging for several critical battery parameters. The following parameters are updated every 10 hours if a difference is detected between values in RAM and data flash:

- Maximum and Minimum Cell Voltages
- Maximum Delta Cell Voltage
- Maximum Charge Current
- Maximum Discharge Current
- Maximum Average Discharge Current
- Maximum Average Discharge Power
- Maximum and Minimum Cell Temperature
- Maximum Delta Cell Temperature
- Maximum and Minimum Internal Sensor Temperature
- Maximum FET Temperature
- Number of Safety Events Occurrences and the Last Cycle of the Occurrence
- Number of Valid Charge Termination and the Last Cycle of the Valid Charge Termination
- Number of Shutdown Events
- Cell Balancing Time for Each Cell
(This data is updated every 2 hours if a difference is detected.)
- Total FW Runtime and Time Spent in Each Temperature Range
(This data is updated every 2 hours if a difference is detected.)

7.3.9 Authentication

The bq4050 gas gauge supports authentication by the host using SHA-1.

7.3.10 LED Display

The bq4050 gas gauge can drive a 3-, 4-, or 5- segment LED display for remaining capacity indication and/or a permanent fail (PF) error code indication.

Feature Description (continued)

7.3.11 Voltage

The bq4050 gas gauge updates the individual series cell voltages at 0.25-s intervals. The internal ADC of the bq4050 device measures the voltage, and scales and calibrates it appropriately. This data is also used to calculate the impedance of the cell for the CEDV gas gauging.

7.3.12 Current

The bq4050 gas gauge uses the SRP and SRN inputs to measure and calculate the battery charge and discharge current using a 1-m Ω to 3-m Ω typ. sense resistor.

7.3.13 Temperature

The bq4050 gas gauge has an internal temperature sensor and inputs for four external temperature sensors. All five temperature sensor options can be individually enabled and configured for cell or FET temperature usage. Two configurable thermistor models are provided to enable monitoring of the cell temperature in addition to the FET temperature, which use a different thermistor profile.

7.3.14 Communications

The bq4050 gas gauge uses SMBus v1.1 with MASTER mode and packet error checking (PEC) options per the SBS specification.

7.3.14.1 SMBus On and Off State

The bq4050 gas gauge detects an SMBus off state when SMBC and SMBD are low for two or more seconds. Clearing this state requires that either SMBC or SMBD transition high. The communication bus will resume activity within 1 ms.

7.3.14.2 SBS Commands

See the *bq4050 Technical Reference Manual* ([SLUUAQ3](#)) for further details.

7.4 Device Functional Modes

The bq4050 gas gauge supports three power modes to reduce power consumption:

- In NORMAL mode, the bq4050 gauge performs measurements, calculations, protection decisions, and data updates in 250-ms intervals. Between these intervals, the bq4050 gauge is in a reduced power stage.
- In SLEEP mode, the bq4050 gauge performs measurements, calculations, protection decisions, and data updates in adjustable time intervals. Between these intervals, the bq4050 gauge is in a reduced power stage. The bq4050 gauge has a wake function that enables exit from SLEEP mode when current flow or failure is detected.
- In SHUTDOWN mode, the bq4050 gauge is completely disabled.

8 Applications and Implementation

NOTE

Information in the following applications sections is not part of the TI component specification, and TI does not warrant its accuracy or completeness. TI's customers are responsible for determining suitability of components for their purposes. Customers should validate and test their design implementation to confirm system functionality.

8.1 Application Information

The bq4050 gas gauge has primary protection support to be used with a 1-series to 4-series Li-Ion/Li Polymer battery pack. To implement and design a comprehensive set of parameters for a specific battery pack, users need the Battery Management Studio ([bqStudio](#)) graphical user-interface tool installed on a PC during development. The firmware installed on the bqStudio tool has default values for this product, which are summarized in the *bq4050 Technical Reference Manual* ([SLUUAQ3](#)). Using the bqStudio tool, these default values can be changed to cater to specific application requirements during development once the system parameters, such as fault trigger thresholds for protection, enable/disable of certain features for operation, configuration of cells, chemistry that best matches the cell used, and more are known. This data is referred to as the "golden image."

Typical Applications (continued)

8.2.1 Design Requirements

Table 1 shows the default settings for the main parameters. Use the [bqStudio](#) tool to update the settings to meet the specific application or battery pack configuration requirements.

The device should be calibrated before any gauging test. Follow the information in the bqStudio **Calibration** page to calibrate the device, and use the bqStudio **Chemistry** page to update the match chemistry profile to the device.

Table 1. Design Parameters

DESIGN PARAMETER	EXAMPLE
Cell Configuration	3s1p (3-series with 1 Parallel) ⁽¹⁾
Design Capacity	4400 mAh
Device Chemistry	1210 (LiCoO ₂ /graphitized carbon)
Cell Overvoltage at Standard Temperature	4300 mV
Cell Undervoltage	2500 mV
Shutdown Voltage	2300 mV
Overcurrent in CHARGE Mode	6000 mA
Overcurrent in DISCHARGE Mode	–6000 mA
Short Circuit in CHARGE Mode	0.1 V/R _{sense} across SRP, SRN
Short Circuit in DISCHARGE Mode	0.1 V/R _{sense} across SRP, SRN
Safety Overvoltage	4500 mV
Cell Balancing	Disabled
Internal and External Temperature Sensor	External Temperature Sensors are used.
Undertemperature Charging	0°C
Undertemperature Discharging	0°C
BROADCAST Mode	Disabled
Battery Trip Point (BTP) with active high interrupt	Disabled

(1) When using the device the first time, if the a 1-s or 2-s battery pack is used, then a charger or power supply should be connected to the PACK+ terminal to prevent device shutdown. Then update the cell configuration (see the [bq4050 Technical Reference Manual \(SLUUAQ3\)](#) for details) before removing the charger connection.

8.2.2 Detailed Design Procedure

8.2.2.1 High-Current Path

The high-current path begins at the PACK+ terminal of the battery pack. As charge current travels through the pack, it finds its way through protection FETs, a chemical fuse, the lithium-ion cells and cell connections, and the sense resistor, and then returns to the PACK– terminal (see [Figure 22](#)). In addition, some components are placed across the PACK+ and PACK– terminals to reduce effects from electrostatic discharge.

8.2.2.1.1 Protection FETs

Select the N-CH charge and discharge FETs for a given application. Most portable battery applications are a good match for the CSD17308Q3. The TI CSD17308Q3 is a 47A, 30-V device with R_{ds(on)} of 8.2 mΩ when the gate drive voltage is 8 V.

If a precharge FET is used, R₁ is calculated to limit the precharge current to the desired rate. Be sure to account for the power dissipation of the series resistor. The precharge current is limited to $(V_{\text{CHARGER}} - V_{\text{BAT}})/R_1$ and maximum power dissipation is $(V_{\text{charger}} - V_{\text{bat}})^2/R_1$.

The gates of all protection FETs are pulled to the source with a high-value resistor between the gate and source to ensure they are turned off if the gate drive is open.

Capacitors C1 and C2 help protect the FETs during an ESD event. Using two devices ensures normal operation if one becomes shorted. To have good ESD protection, the copper trace inductance of the capacitor leads must be designed to be as short and wide as possible. Ensure that the voltage ratings of C1 and C2 are adequate to hold off the applied voltage if one of the capacitors becomes shorted.

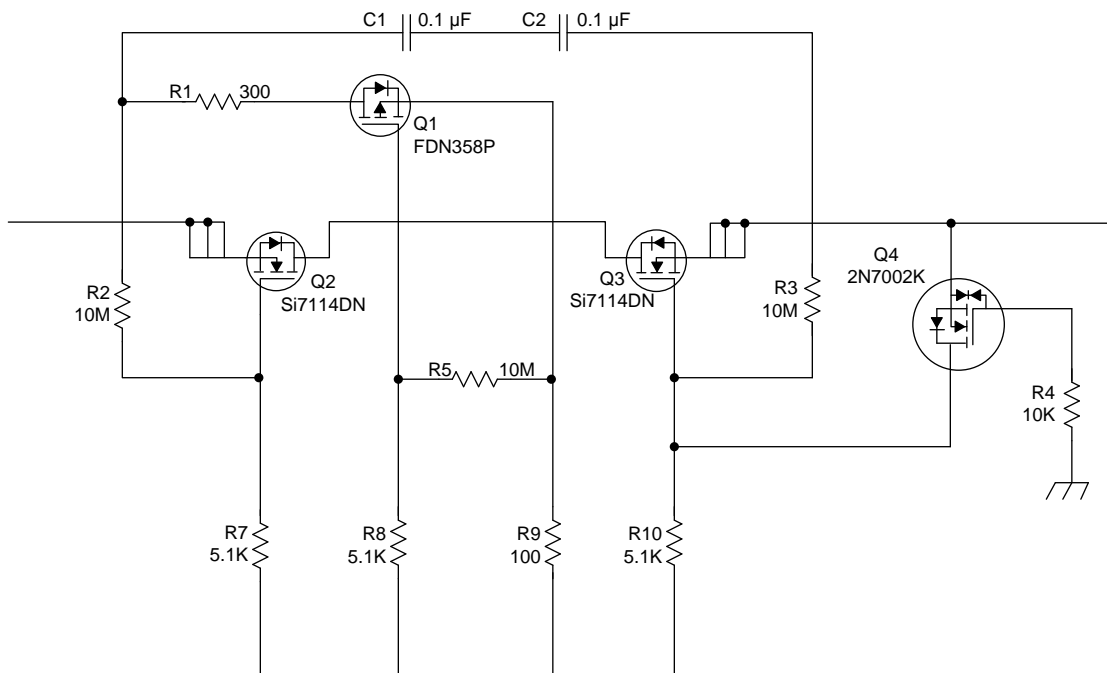

Copyright © 2016, Texas Instruments Incorporated

Figure 22. bq4050 Protection FETs

8.2.2.1.2 Chemical Fuse

The chemical fuse (Dexerials, Uchihashi, and so on) is ignited under command from either the bq294700 secondary voltage protection IC or from the FUSE pin of the gas gauge. Either of these events applies a positive voltage to the gate of Q5, shown in [Figure 23](#), which then sinks current from the third terminal of the fuse, causing it to ignite and open permanently.

It is important to carefully review the fuse specifications and match the required ignition current to that available from the N-CH FET. Ensure that the proper voltage, current, and $R_{ds(on)}$ ratings are used for this device. The fuse control circuit is discussed in detail in [FUSE Circuitry](#).

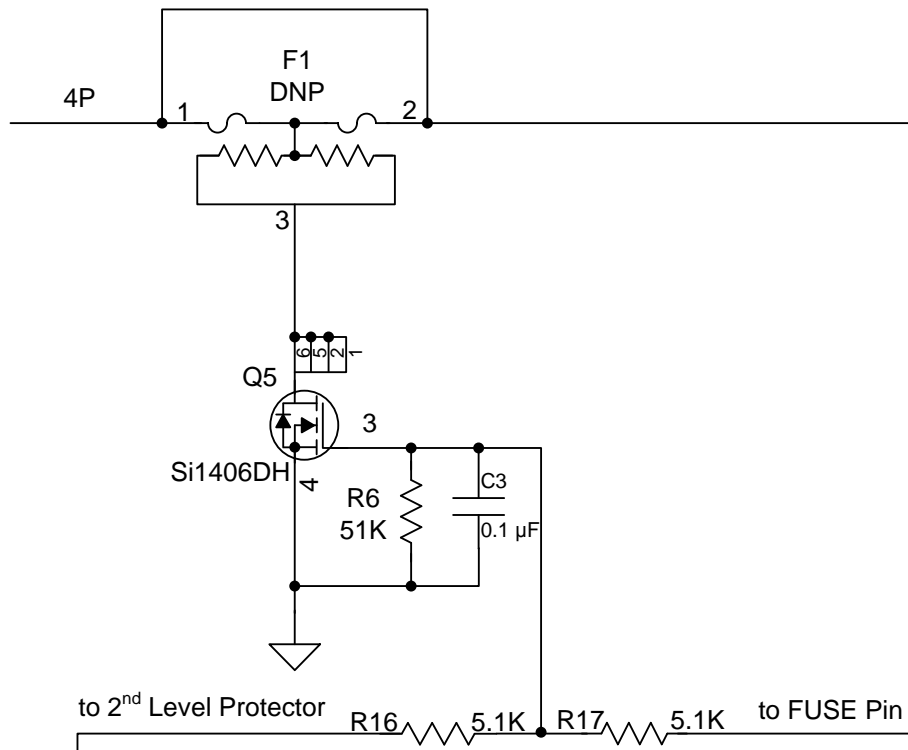

Copyright © 2016, Texas Instruments Incorporated

Figure 23. FUSE Circuit

8.2.2.1.3 Lithium-Ion Cell Connections

The important part to remember about the cell connections is that high current flows through the top and bottom connections; therefore, the voltage sense leads at these points must be made with a Kelvin connection to avoid any errors due to a drop in the high-current copper trace. The location marked 4P in Figure 24 indicates the Kelvin connection of the most positive battery node. The connection marked 1N is equally important. The VC5 pin (a ground reference for cell voltage measurement), which is in the older generation devices, is not in the bq4050 device. Therefore, the single-point connection at 1N to the low-current ground is needed to avoid an undesired voltage drop through long traces while the gas gauge is measuring the bottom cell voltage.

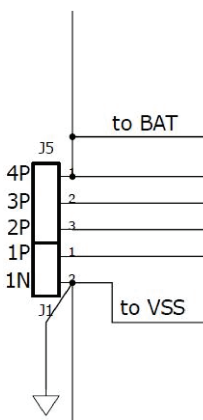
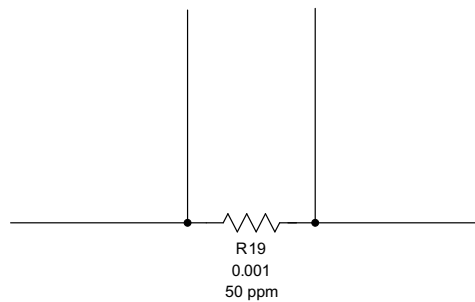

Figure 24. Lithium-Ion Cell Connections

8.2.2.1.4 Sense Resistor

As with the cell connections, the quality of the Kelvin connections at the sense resistor is critical. The sense resistor must have a temperature coefficient no greater than 50 ppm in order to minimize current measurement drift with temperature. Choose the value of the sense resistor to correspond to the available overcurrent and short-circuit ranges of the bq4050 gauge. Select the smallest value possible to minimize the negative voltage generated on the bq4050 V_{SS} node(s) during a short circuit. This pin has an absolute minimum of -0.3 V. Parallel resistors can be used as long as good Kelvin sensing is ensured. The device is designed to support a $1\text{-m}\Omega$ to $3\text{-m}\Omega$ sense resistor.

The ground scheme of bq4050 gauge is different from the older generation devices. In previous devices, the device ground (or low current ground) is connected to the SRN side of the Rsense resistor pad. The bq4050 gauge, however, it connects the low-current ground on the SRP side of the Rsense resistor pad close to the battery 1N terminal (see [Lithium-Ion Cell Connections](#)). This is because the bq4050 gauge has one less VC pin (a ground reference pin VC5) compared to the previous devices. The pin was removed and was internally combined to SRP.



Copyright © 2016, Texas Instruments Incorporated

Figure 25. Sense Resistor

8.2.2.1.5 ESD Mitigation

A pair of series $0.1\text{-}\mu\text{F}$ ceramic capacitors is placed across the PACK+ and PACK– terminals to help in the mitigation of external electrostatic discharges. The two devices in series ensure continued operation of the pack if one of the capacitors becomes shorted.

Optionally, a tranzorb such as the SMBJ2A can be placed across the terminals to further improve ESD immunity.

8.2.2.2 Gas Gauge Circuit

The gas gauge circuit includes the bq4050 gauge and its peripheral components. These components are divided into the following groups: Differential Low-Pass Filter, PBI, system present, SMBus Communication, FUSE circuit, and LED.

8.2.2.2.1 Coulomb-Counting Interface

The bq4050 gauge uses an integrating delta-sigma ADC for current measurements. Add a $100\text{-}\Omega$ resistor from the sense resistor to the SRP and SRN inputs of the device. Place a $0.1\text{-}\mu\text{F}$ (C18) filter capacitor across the SRP and SRN inputs. Optional $0.1\text{-}\mu\text{F}$ filter capacitors (C19 and C20) can be added for additional noise filtering if required for a circuit.

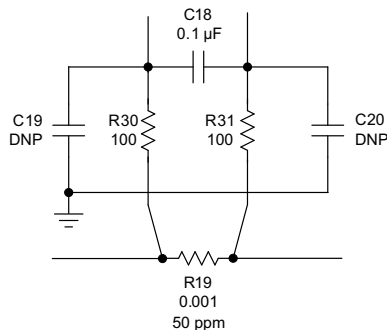

Copyright © 2016, Texas Instruments Incorporated

Figure 26. Differential Filter

8.2.2.2.2 Power Supply Decoupling and PBI

The bq4050 gauge has an internal LDO that is internally compensated and does not require an external decoupling capacitor.

The PBI pin is used as a power supply backup input pin providing power during brief transient power outages. A standard 2.2-μF ceramic capacitor is connected from the PBI pin to ground as shown in Figure 27.

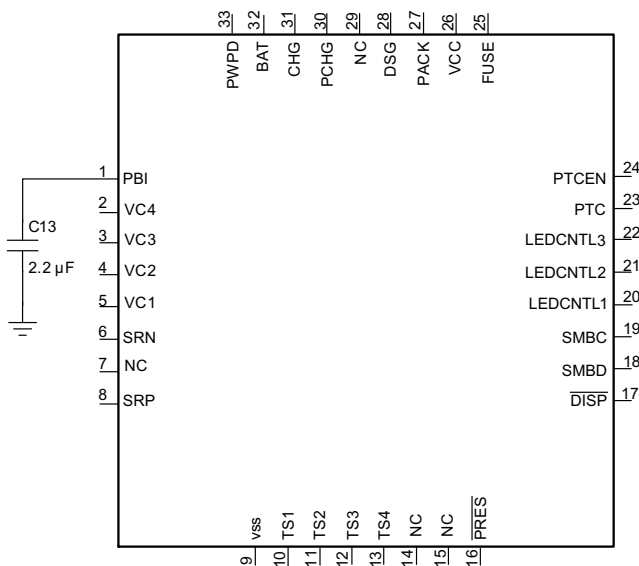

Copyright © 2016, Texas Instruments Incorporated

Figure 27. Power Supply Decoupling

8.2.2.2.3 System Present

The system present signal is used to inform the gas gauge whether the pack is installed into or removed from the system. In the host system, this pin is grounded. The PRES pin of the bq4050 gauge is occasionally sampled to test for system present. To save power, an internal pullup is provided by the gas gauge during a brief 4-μs sampling pulse once per second. A resistor can be used to pull the signal low and the resistance must be 20 kΩ or lower to ensure that the test pulse is lower than the VIL limit. The pullup current source is typically 10 μA to 20 μA.

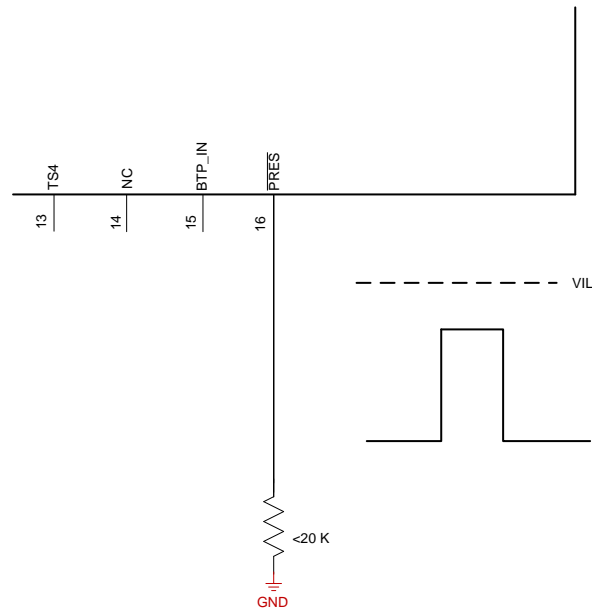

Copyright © 2016, Texas Instruments Incorporated

Figure 28. System Present Pull-Down Resistor

Because the system present signal is part of the pack connector interface to the outside world, it must be protected from external electrostatic discharge events. An integrated ESD protection on the PRES device pin reduces the external protection requirement to just R29 for an 8-kV ESD contact rating. However, if it is possible that the system present signal may short to PACK+, then R28 and D4 must be included for high-voltage protection.

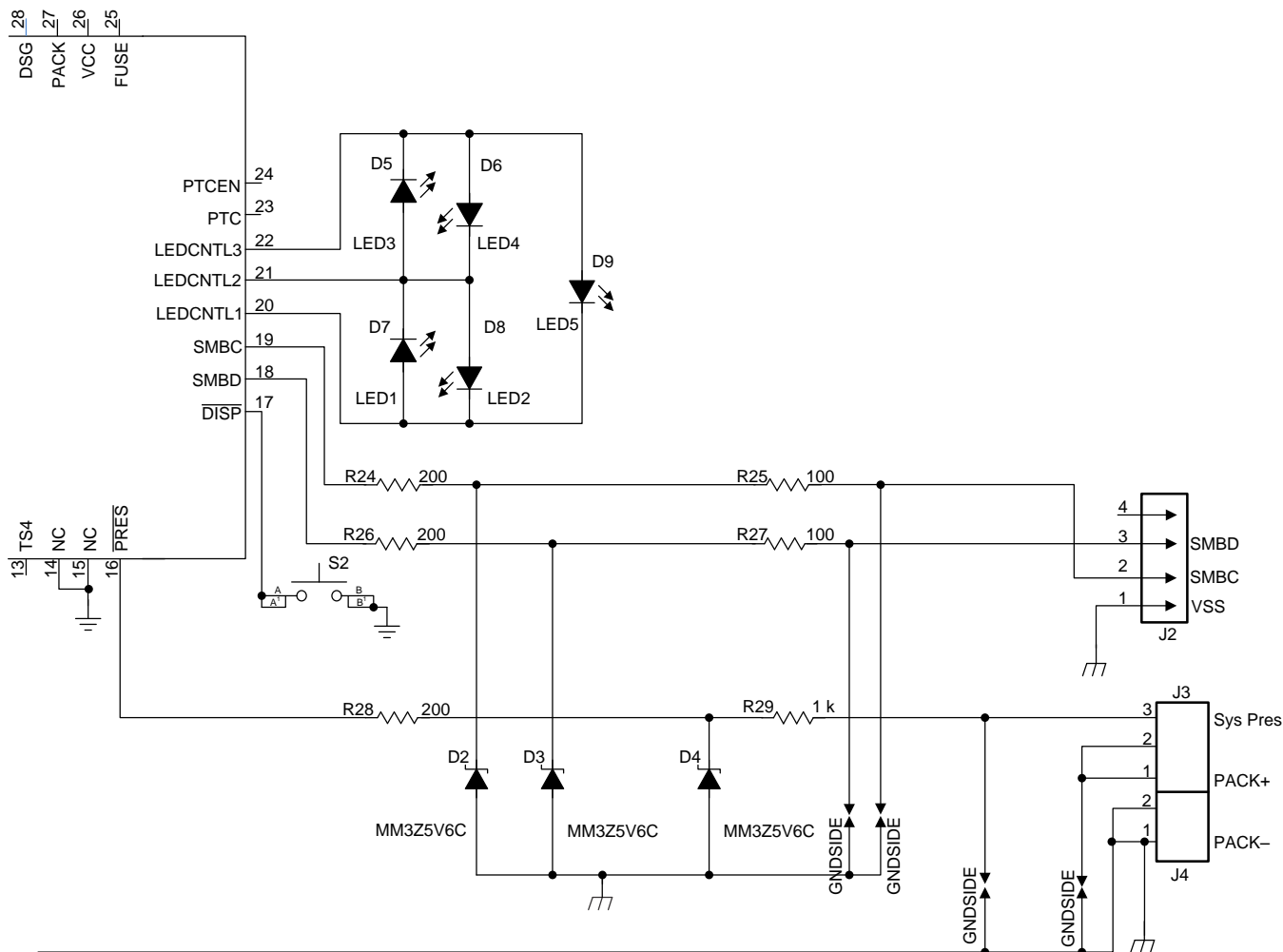

Copyright © 2016, Texas Instruments Incorporated

Figure 29. System Present ESD and Short Protection

8.2.2.2.4 SMBus Communication

The SMBus clock and data pins have integrated high-voltage ESD protection circuits; however, adding a Zener diode (D2 and D3) and series resistor (R24 and R26) provides more robust ESD performance.

The SMBus clock and data lines have internal pulldown. When the gas gauge senses that both lines are low (such as during removal of the pack), the device performs auto-offset calibration and then goes into SLEEP mode to conserve power.

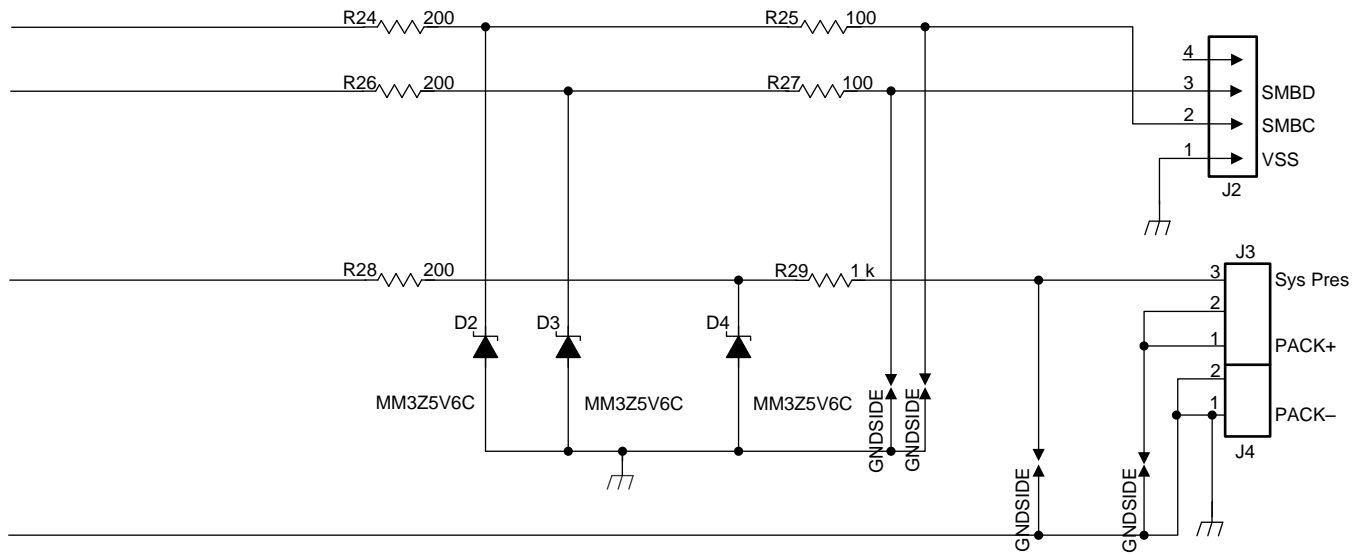

Copyright © 2016, Texas Instruments Incorporated

Figure 30. ESD Protection for SMB Communication

8.2.2.2.5 FUSE Circuitry

The FUSE pin of the bq4050 gauge is designed to ignite the chemical fuse if one of the various safety criteria is violated. The FUSE pin also monitors the state of the secondary-voltage protection IC. Q5 ignites the chemical fuse when its gate is high. The 7-V output of the bq294700 is divided by R16 and R6, which provides adequate gate drive for Q5 while guarding against excessive back current into the bq294700 if the FUSE signal is high.

Using C3 is generally a good practice, especially for RFI immunity. C3 may be removed, if desired, because the chemical fuse is a comparatively slow device and is not affected by any submicrosecond glitches that come from the FUSE output during the cell connection process.

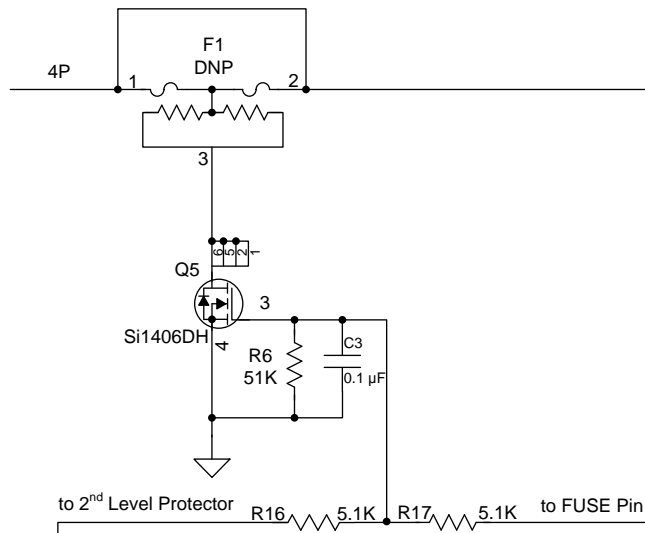

Copyright © 2016, Texas Instruments Incorporated

Figure 31. FUSE Circuit

When the bq4050 gauge is commanded to ignite the chemical fuse, the FUSE pin activates to give a typical 8-V output. The new design makes it possible to use a higher Vgs FET for Q5. This improves the robustness of the system, as well as widens the choices for Q5.

8.2.2.3 Secondary-Current Protection

The bq4050 gauge provides secondary overcurrent and short-circuit protection, cell balancing, cell voltage multiplexing, and voltage translation. The following discussion examines cell and battery inputs, pack and FET control, temperature output, and cell balancing.

8.2.2.3.1 Cell and Battery Inputs

Each cell input is conditioned with a simple RC filter, which provides ESD protection during cell connect and acts to filter unwanted voltage transients. The resistor value allows some trade-off for cell balancing versus safety protection.

The integrated cell balancing FETs allow the AFE to bypass cell current around a given cell or numerous cells, effectively balancing the entire battery stack. External series resistors placed between the cell connections and the VCx I/O pins set the balancing current magnitude. The internal FETs provide a 200-Ω resistance ($2\text{ V} < \text{VDS} < 4\text{ V}$). Series input resistors between 100 Ω and 1 kΩ are recommended for effective cell balancing.

The BAT input uses a diode (D1) to isolate and decouple it from the cells in the event of a transient dip in voltage caused by a short-circuit event.

Also, as described in [High-Current Path](#), the top and bottom nodes of the cells must be sensed at the battery connections with a Kelvin connection to prevent voltage sensing errors caused by a drop in the high-current PCB copper.

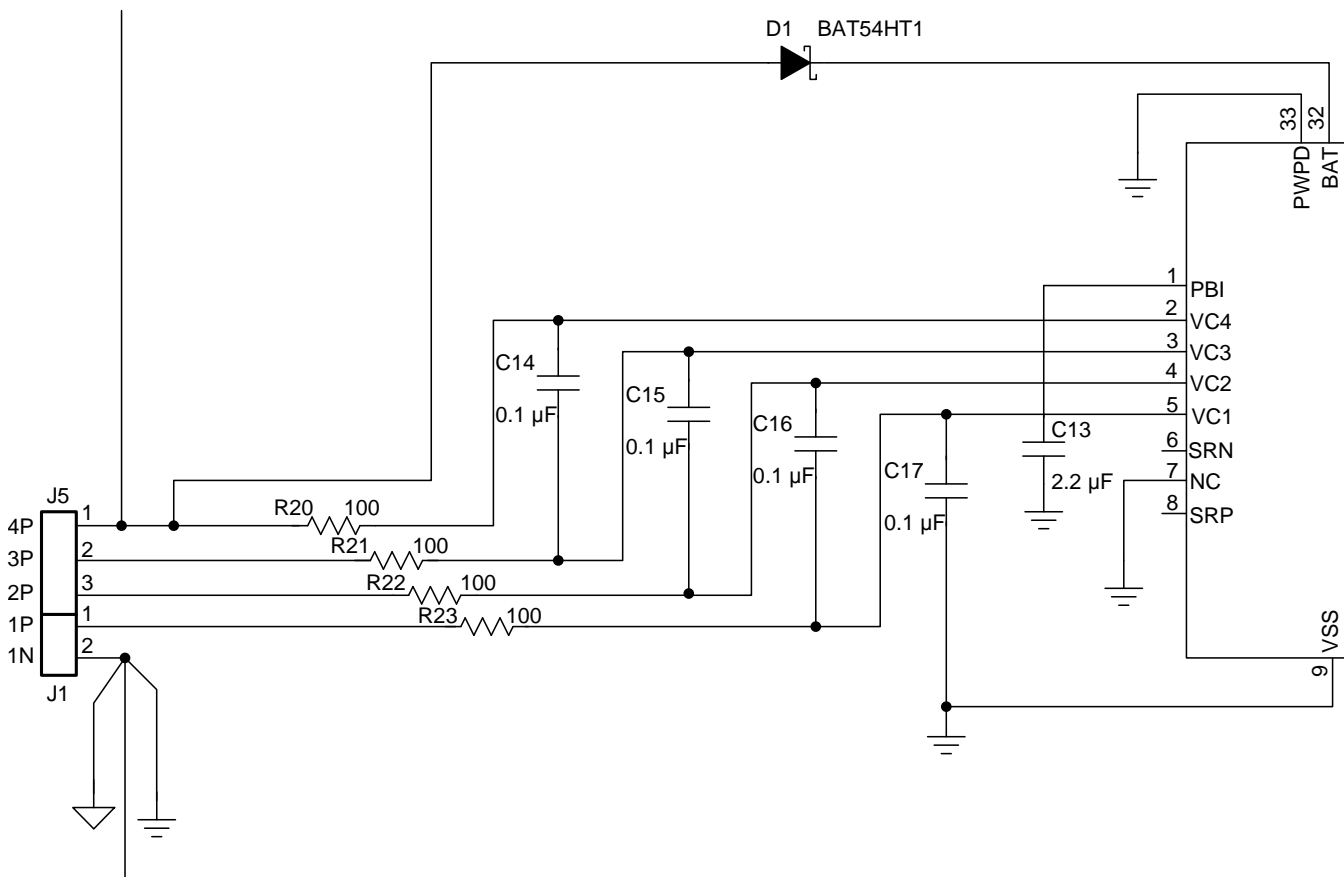

Copyright © 2016, Texas Instruments Incorporated

Figure 32. Cell and BAT Inputs

8.2.2.3.2 External Cell Balancing

Internal cell balancing can only support up to 10 mA. External cell balancing is provided as another option for faster cell balancing. For details, refer to the application note, [Fast Cell Balancing Using External MOSFET \(SLUA420\)](#).

8.2.2.3.3 PACK and FET Control

The PACK and V_{CC} inputs provide power to the bq4050 gauge from the charger. The PACK input also provides a method to measure and detect the presence of a charger. The PACK input uses a 100- Ω resistor; whereas, the V_{CC} input uses a diode to guard against input transients and prevents misoperation of the data driver during short-circuit events.

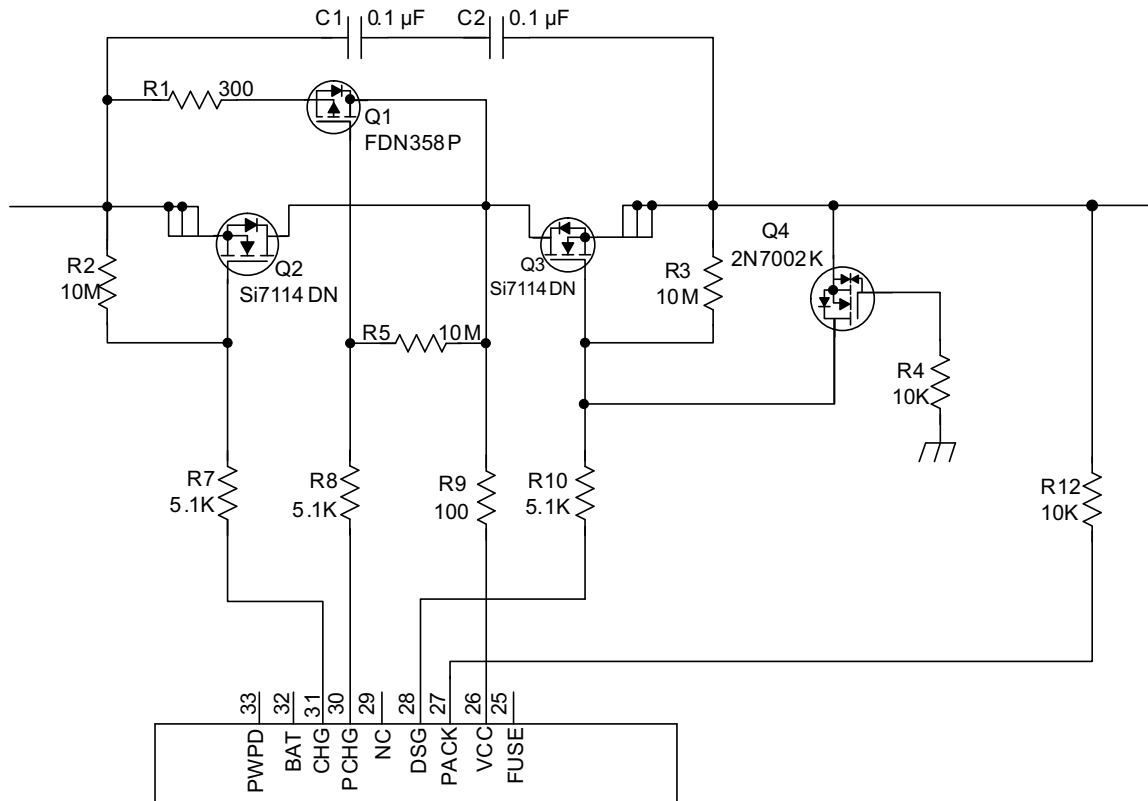

Copyright © 2016, Texas Instruments Incorporated

Figure 33. bq4050 PACK and FET Control

The N-CH charge and discharge FETs are controlled with 5.1-k Ω series gate resistors, which provide a switching time constant of a few microseconds. The 10-M Ω resistors ensure that the FETs are off in the event of an open connection to the FET drivers. Q4 is provided to protect the discharge FET (Q3) in the event of a reverse-connected charger. Without Q4, Q3 can be driven into its linear region and suffer severe damage if the PACK+ input becomes slightly negative.

Q4 turns on in that case to protect Q3 by shorting its gate to source. To use the simple ground gate circuit, the FET must have a low gate turn-on threshold. If it is desired to use a more standard device, such as the 2N7002 as the reference schematic, the gate should be biased up to 3.3 V with a high-value resistor. The bq4050 device has the capability to provide a current-limited charging path typically used for low battery voltage or low temperature charging. The bq4050 device uses an external P-channel, precharge FET controlled by PCHG.

8.2.2.3.4 Temperature Output

For the bq4050 device, TS1, TS2, TS3, and TS4 provide thermistor drive-under program control. Each pin can be enabled with an integrated 18-k Ω (typical) linearization pullup resistor to support the use of a 10-k Ω at 25 $^{\circ}$ C (103) NTC external thermistor, such as a Mitsubishi BN35-3H103. The reference design includes four 10-k Ω thermistors: RT1, RT2, RT3, and RT4. The bq4050 device supports up to four external thermistors. Connect unused thermistor pins to V_{SS} .

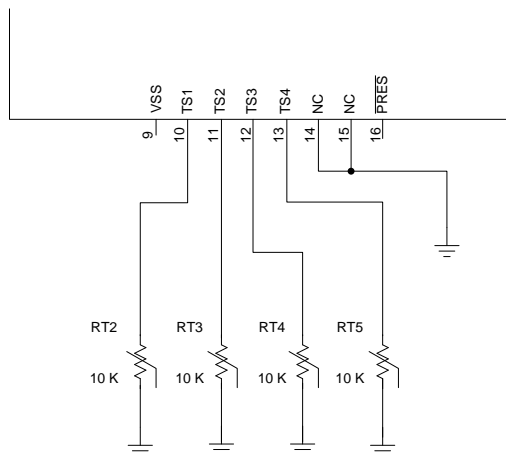

Copyright © 2016, Texas Instruments Incorporated

Figure 34. Thermistor Drive

8.2.2.3.5 LEDs

Three LED control outputs provide constant current sinks for the driving external LEDs. These outputs are configured to provide voltage and control for up to 5 LEDs. No external bias voltage is required. Unused LEDCNTL pins can remain open or they can be connected to V_{SS}. The $\overline{\text{DISP}}$ pin should be connected to V_{SS}, if the LED feature is not used.

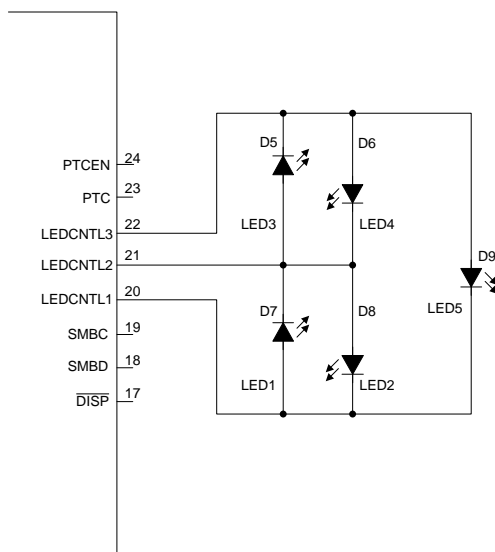

Copyright © 2016, Texas Instruments Incorporated

Figure 35. LEDs

8.2.2.3.6 Safety PTC Thermistor

The bq4050 device provides support for a safety PTC thermistor. The PTC thermistor is connected between PTC and PTCEN, and PTCEN is connected to BAT. It can be placed close to the CHG/DSG FETs to monitor the temperature. A PTC fault is one of the permanent failure modes. It can only be cleared by a POR.

To disable, connect PTC and PTCEN to V_{SS}.

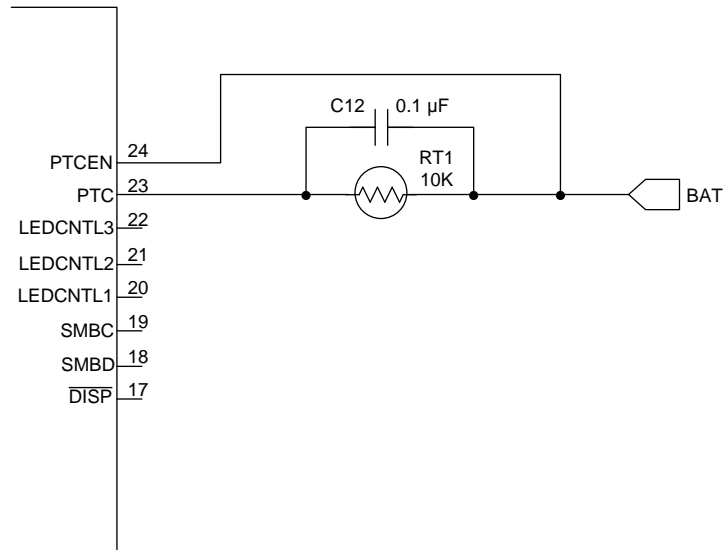

Copyright © 2016, Texas Instruments Incorporated

Figure 36. PTC Thermistor

8.2.3 Application Curves

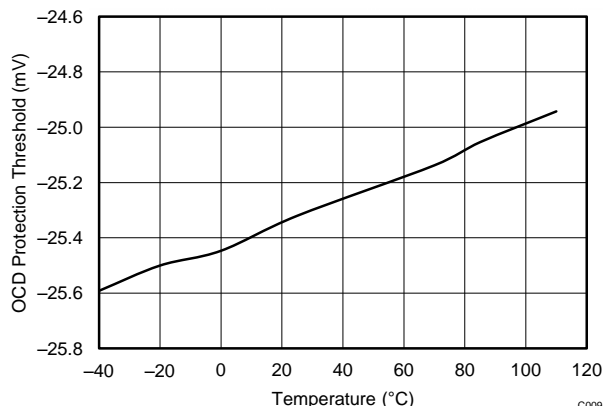

Threshold setting is -25 mV.

Figure 37. Overcurrent Discharge Protection Threshold Vs. Temperature

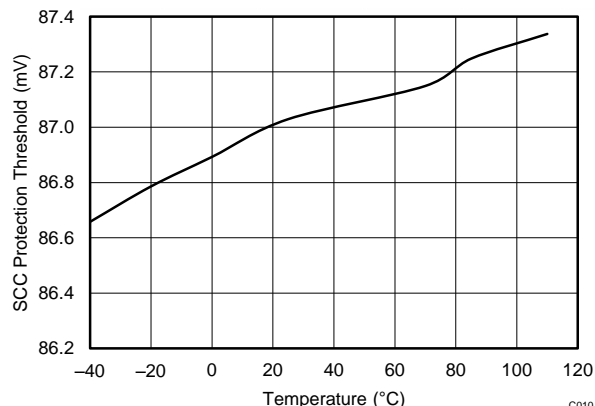

Threshold setting is 88.85 mV.

Figure 38. Short Circuit Charge Protection Threshold Vs. Temperature

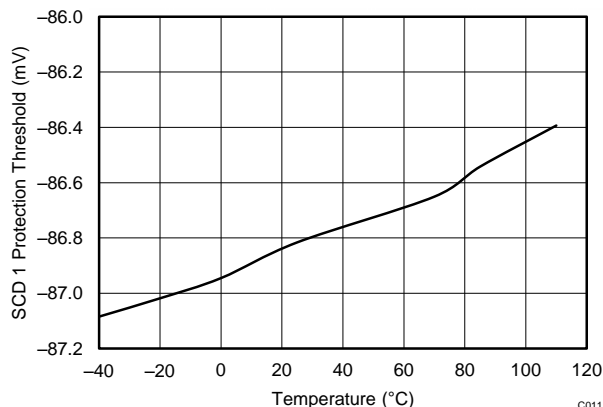

Threshold setting is -88.85 mV.

Figure 39. Short Circuit Discharge 1 Protection Threshold Vs. Temperature

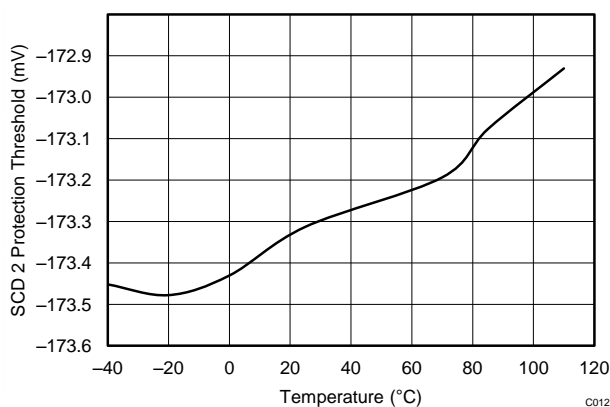

Threshold setting is -177.7 mV.

Figure 40. Short Circuit Discharge 2 Protection Threshold Vs. Temperature

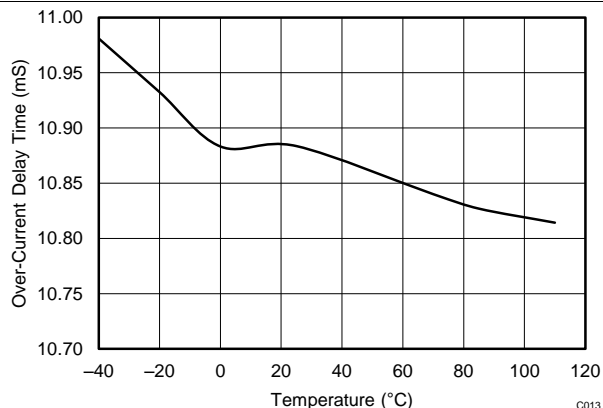

Threshold setting is 11 ms.

Figure 41. Overcurrent Delay Time Vs. Temperature

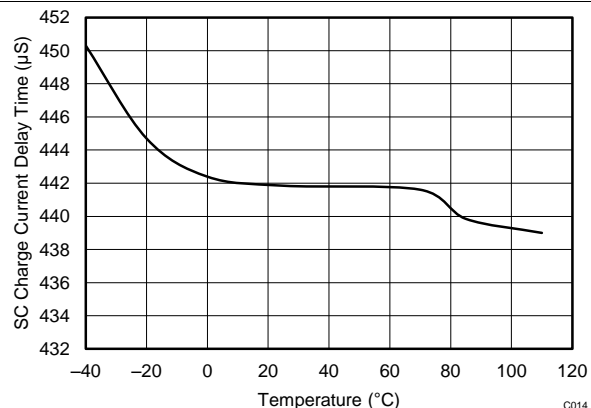

Threshold setting is 465 µs.

Figure 42. Short Circuit Charge Current Delay Time Vs. Temperature

9 Power Supply Recommendations

The device manages its supply voltage dynamically according to the operation conditions. Normally, the BAT input is the primary power source to the device. The BAT pin should be connected to the positive termination of the battery stack. The input voltage for the BAT pin ranges from 2.2 V to 26 V.

The VCC pin is the secondary power input, which activates when the BAT voltage falls below minimum V_{CC} . This allows the device to source power from a charger (if present) connected to the PACK pin. The VCC pin should be connected to the common drain of the CHG and DSG FETs. The charger input should be connected to the PACK pin.

10 Layout

10.1 Layout Guidelines

A battery fuel gauge circuit board is a challenging environment due to the fundamental incompatibility of high-current traces and ultra-low current semiconductor devices. The best way to protect against unwanted trace-to-trace coupling is with a component placement, such as that shown in [Figure 43](#), where the high-current section is on the opposite side of the board from the electronic devices. Clearly, this is not possible in many situations due to mechanical constraints. Still, every attempt should be made to route high-current traces away from signal traces, which enter the bq4050 gauge directly. IC references and registers can be disturbed and in rare cases damaged due to magnetic and capacitive coupling from the high-current path.

NOTE

During surge current and ESD events, the high-current traces appear inductive and can couple unwanted noise into sensitive nodes of the gas gauge electronics, as illustrated in [Figure 44](#).

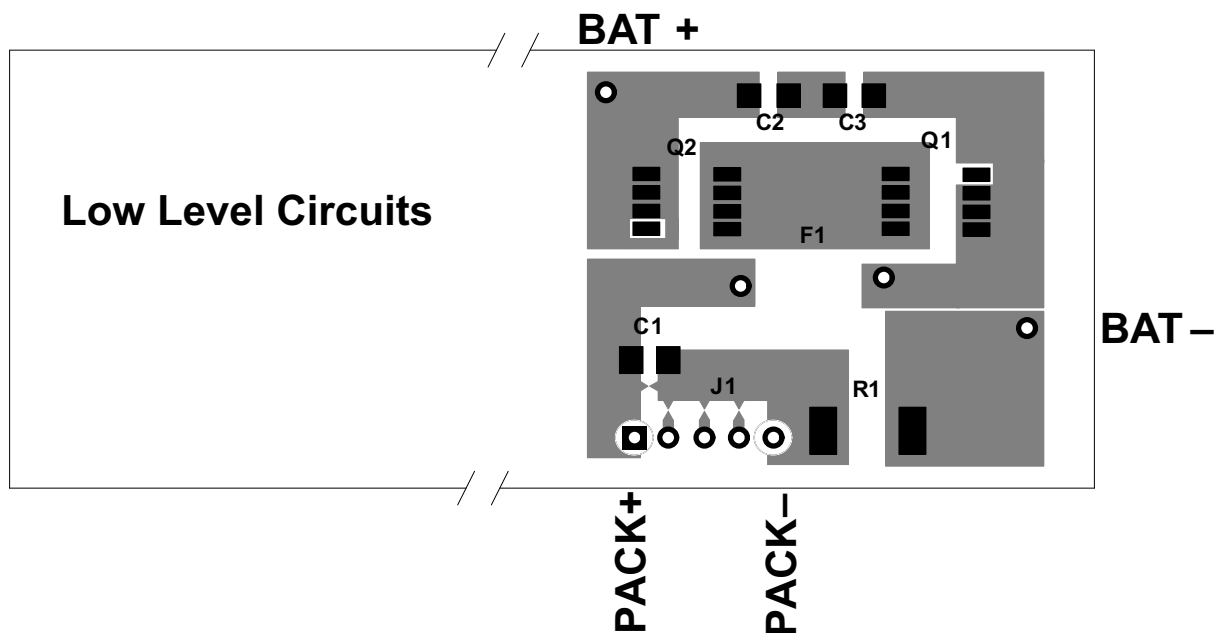

Copyright © 2016, Texas Instruments Incorporated

Figure 43. Separating High- and Low-Current Sections Provides an Advantage in Noise Immunity

Layout Guidelines (continued)

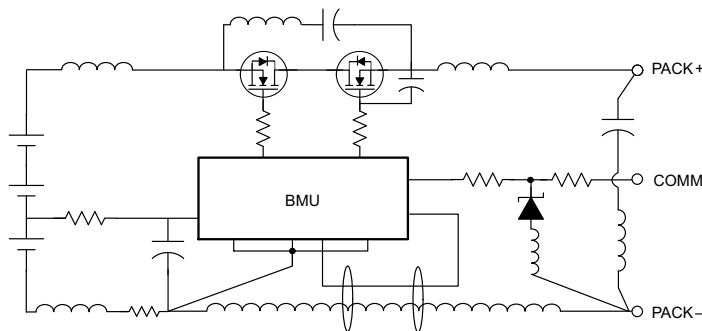

Copyright © 2016, Texas Instruments Incorporated

Figure 44. Avoid Close Spacing Between High-Current and Low-Level Signal Lines

Kelvin voltage sensing is important to accurately measure current and top and bottom cell voltages. Place all filter components as close as possible to the device. Route the traces from the sense resistor in parallel to the filter circuit. Adding a ground plane around the filter network can add additional noise immunity. Figure 45 and Figure 46 demonstrate correct kelvin current sensing.

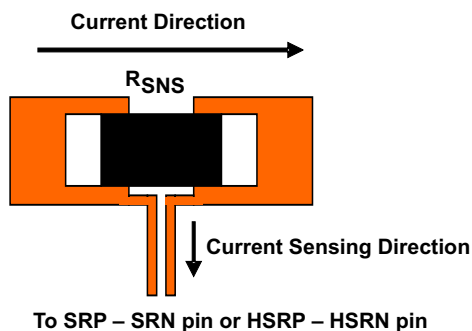

Figure 45. Sensing Resistor PCB Layout

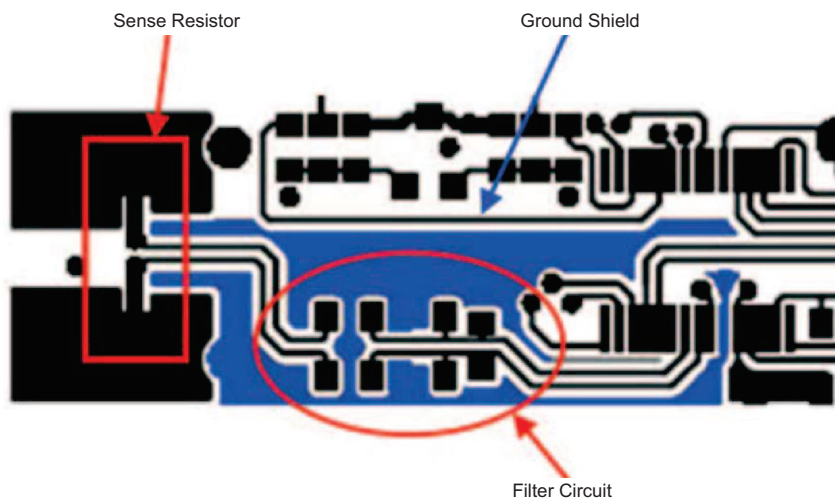
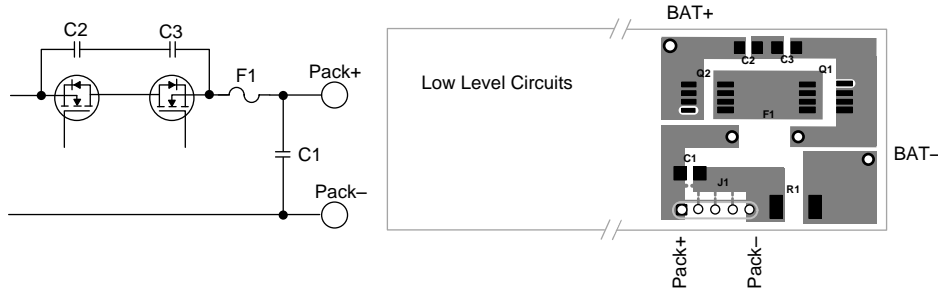

Figure 46. Sense Resistor, Ground Shield, and Filter Circuit Layout

Layout Guidelines (continued)

10.1.1 Protector FET Bypass and Pack Terminal Bypass Capacitors

Use wide copper traces to lower the inductance of the bypass capacitor circuit. In [Figure 47](#), an example layout demonstrates this technique.



Copyright © 2016, Texas Instruments Incorporated

Figure 47. Use Wide Copper Traces to Lower the Inductance of Bypass Capacitors C1, C2, and C3

10.1.2 ESD Spark Gap

Protect the SMBus clock, data, and other communication lines from ESD with a spark gap at the connector. The pattern in [Figure 48](#) is recommended, with 0.2-mm spacing between the points.



Figure 48. Recommended Spark-Gap Pattern Helps Protect Communication Lines from ESD

10.2 Layout Example

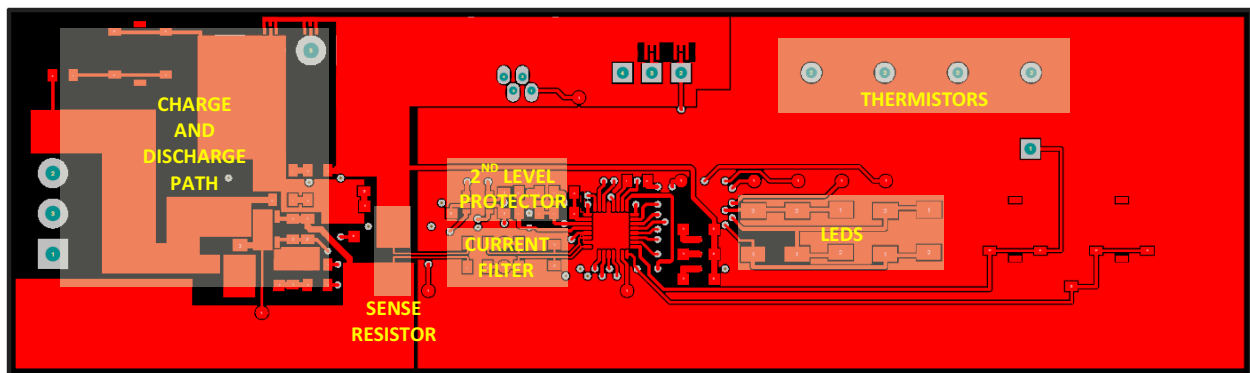

Figure 49. Top Layer

Layout Example (continued)

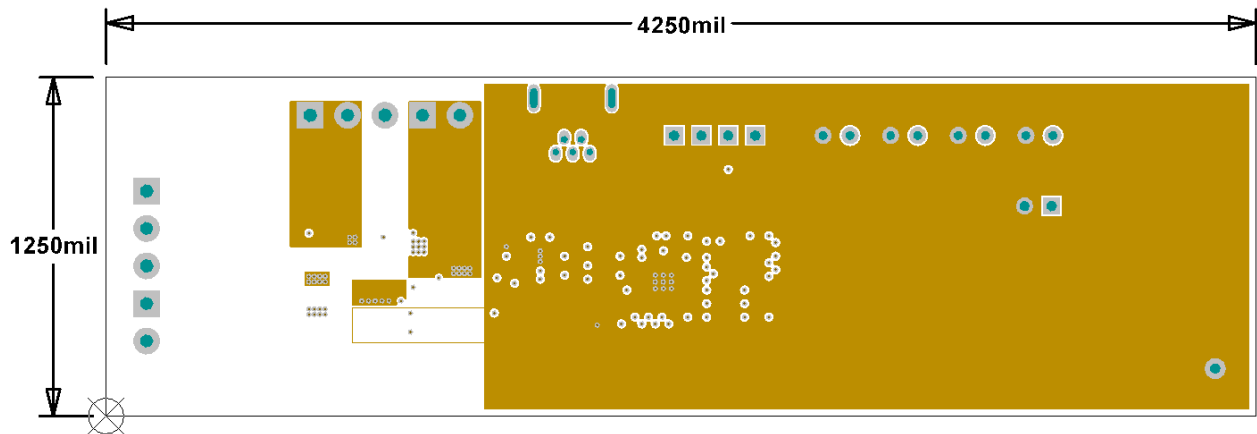

Figure 50. Internal Layer 1

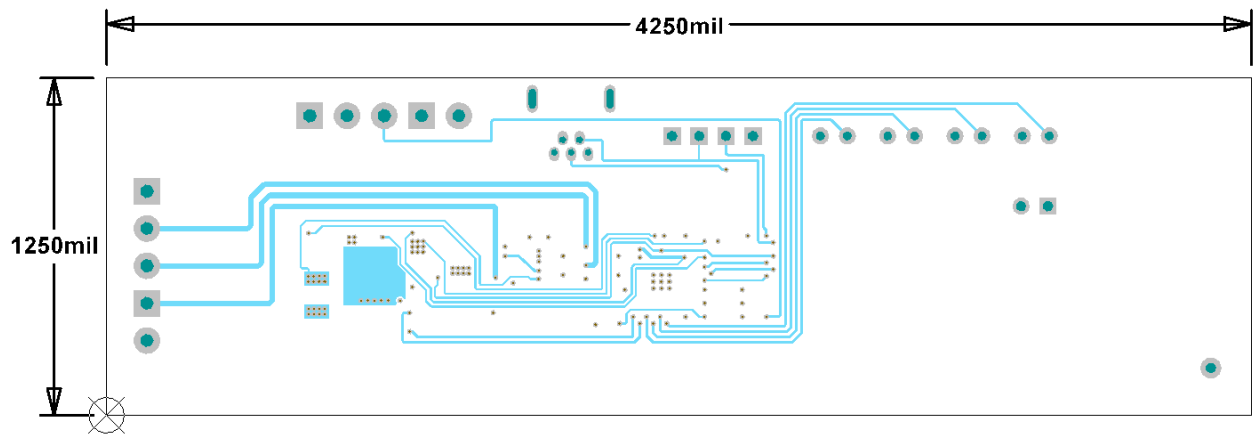

Figure 51. Internal Layer 2

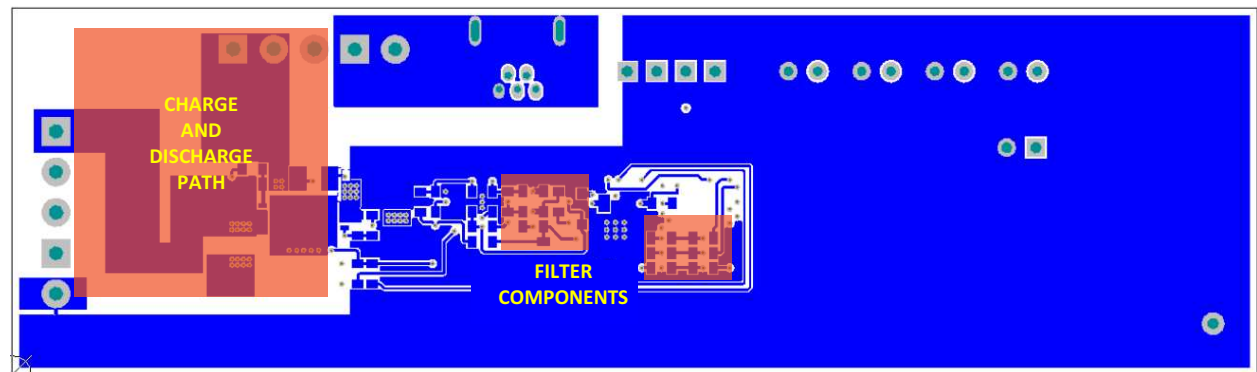

Figure 52. Bottom Layer

11 Device and Documentation Support

11.1 Documentation Support

11.1.1 Related Documentation

For related documentation, see the *bq4050 Technical Reference Manual* ([SLUUAQ3](#)).

11.2 Community Resources

The following links connect to TI community resources. Linked contents are provided "AS IS" by the respective contributors. They do not constitute TI specifications and do not necessarily reflect TI's views; see TI's [Terms of Use](#).

TI E2E™ Online Community *TI's Engineer-to-Engineer (E2E) Community*. Created to foster collaboration among engineers. At [e2e.ti.com](#), you can ask questions, share knowledge, explore ideas and help solve problems with fellow engineers.

Design Support *TI's Design Support* Quickly find helpful E2E forums along with design support tools and contact information for technical support.

11.3 Trademarks

E2E is a trademark of Texas Instruments.
Windows is a registered trademark of Microsoft.
All other trademarks are the property of their respective owners.

11.4 Electrostatic Discharge Caution



This integrated circuit can be damaged by ESD. Texas Instruments recommends that all integrated circuits be handled with appropriate precautions. Failure to observe proper handling and installation procedures can cause damage.

ESD damage can range from subtle performance degradation to complete device failure. Precision integrated circuits may be more susceptible to damage because very small parametric changes could cause the device not to meet its published specifications.

11.5 Glossary

[SLYZ022](#) — *TI Glossary*.

This glossary lists and explains terms, acronyms, and definitions.

12 Mechanical, Packaging, and Orderable Information

The following pages include mechanical, packaging, and orderable information. This information is the most current data available for the designated devices. This data is subject to change without notice and revision of this document. For browser-based versions of this data sheet, refer to the left-hand navigation.

PACKAGING INFORMATION

Orderable part number	Status (1)	Material type (2)	Package Pins	Package qty Carrier	RoHS (3)	Lead finish/ Ball material (4)	MSL rating/ Peak reflow (5)	Op temp (°C)	Part marking (6)
BQ4050RSMR	Active	Production	VQFN (RSM) 32	3000 LARGE T&R	Yes	NIPDAU	Level-1-260C-UNLIM	-40 to 85	BQ4050
BQ4050RSMR.Z	Active	Production	VQFN (RSM) 32	3000 LARGE T&R	Yes	NIPDAU	Level-1-260C-UNLIM	-40 to 85	BQ4050
BQ4050RSMT	Active	Production	VQFN (RSM) 32	250 SMALL T&R	Yes	NIPDAU	Level-1-260C-UNLIM	-40 to 85	BQ4050
BQ4050RSMT.Z	Active	Production	VQFN (RSM) 32	250 SMALL T&R	Yes	NIPDAU	Level-1-260C-UNLIM	-40 to 85	BQ4050

(1) **Status:** For more details on status, see our [product life cycle](#).

(2) **Material type:** When designated, preproduction parts are prototypes/experimental devices, and are not yet approved or released for full production. Testing and final process, including without limitation quality assurance, reliability performance testing, and/or process qualification, may not yet be complete, and this item is subject to further changes or possible discontinuation. If available for ordering, purchases will be subject to an additional waiver at checkout, and are intended for early internal evaluation purposes only. These items are sold without warranties of any kind.

(3) **RoHS values:** Yes, No, RoHS Exempt. See the [TI RoHS Statement](#) for additional information and value definition.

(4) **Lead finish/Ball material:** Parts may have multiple material finish options. Finish options are separated by a vertical ruled line. Lead finish/Ball material values may wrap to two lines if the finish value exceeds the maximum column width.

(5) **MSL rating/Peak reflow:** The moisture sensitivity level ratings and peak solder (reflow) temperatures. In the event that a part has multiple moisture sensitivity ratings, only the lowest level per JEDEC standards is shown. Refer to the shipping label for the actual reflow temperature that will be used to mount the part to the printed circuit board.

(6) **Part marking:** There may be an additional marking, which relates to the logo, the lot trace code information, or the environmental category of the part.

Multiple part markings will be inside parentheses. Only one part marking contained in parentheses and separated by a "~" will appear on a part. If a line is indented then it is a continuation of the previous line and the two combined represent the entire part marking for that device.

Important Information and Disclaimer: The information provided on this page represents TI's knowledge and belief as of the date that it is provided. TI bases its knowledge and belief on information provided by third parties, and makes no representation or warranty as to the accuracy of such information. Efforts are underway to better integrate information from third parties. TI has taken and continues to take reasonable steps to provide representative and accurate information but may not have conducted destructive testing or chemical analysis on incoming materials and chemicals. TI and TI suppliers consider certain information to be proprietary, and thus CAS numbers and other limited information may not be available for release.

In no event shall TI's liability arising out of such information exceed the total purchase price of the TI part(s) at issue in this document sold by TI to Customer on an annual basis.

TAPE AND REEL INFORMATION



QUADRANT ASSIGNMENTS FOR PIN 1 ORIENTATION IN TAPE



*All dimensions are nominal

Device	Package Type	Package Drawing	Pins	SPQ	Reel Diameter (mm)	Reel Width W1 (mm)	A0 (mm)	B0 (mm)	K0 (mm)	P1 (mm)	W (mm)	Pin1 Quadrant
BQ4050RSMR	VQFN	RSM	32	3000	330.0	12.4	4.25	4.25	1.15	8.0	12.0	Q2
BQ4050RSMT	VQFN	RSM	32	250	180.0	12.4	4.25	4.25	1.15	8.0	12.0	Q2

TAPE AND REEL BOX DIMENSIONS



*All dimensions are nominal

Device	Package Type	Package Drawing	Pins	SPQ	Length (mm)	Width (mm)	Height (mm)
BQ4050RSMR	VQFN	RSM	32	3000	367.0	367.0	35.0
BQ4050RSMT	VQFN	RSM	32	250	210.0	185.0	35.0

GENERIC PACKAGE VIEW

RSM 32

VQFN - 1 mm max height

4 x 4, 0.4 mm pitch

PLASTIC QUAD FLATPACK - NO LEAD

This image is a representation of the package family, actual package may vary.
Refer to the product data sheet for package details.

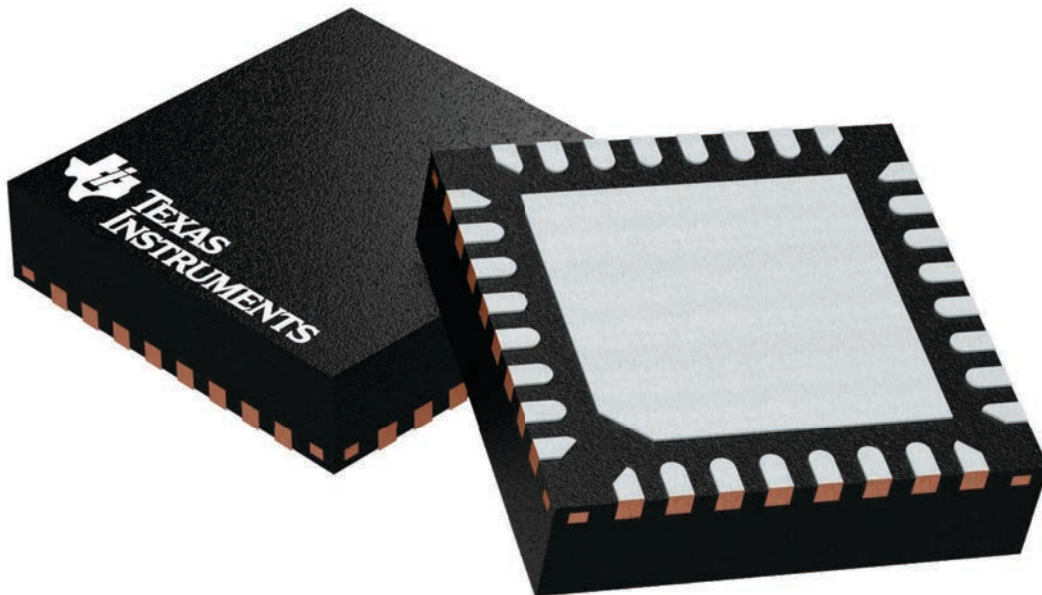

4224982/A

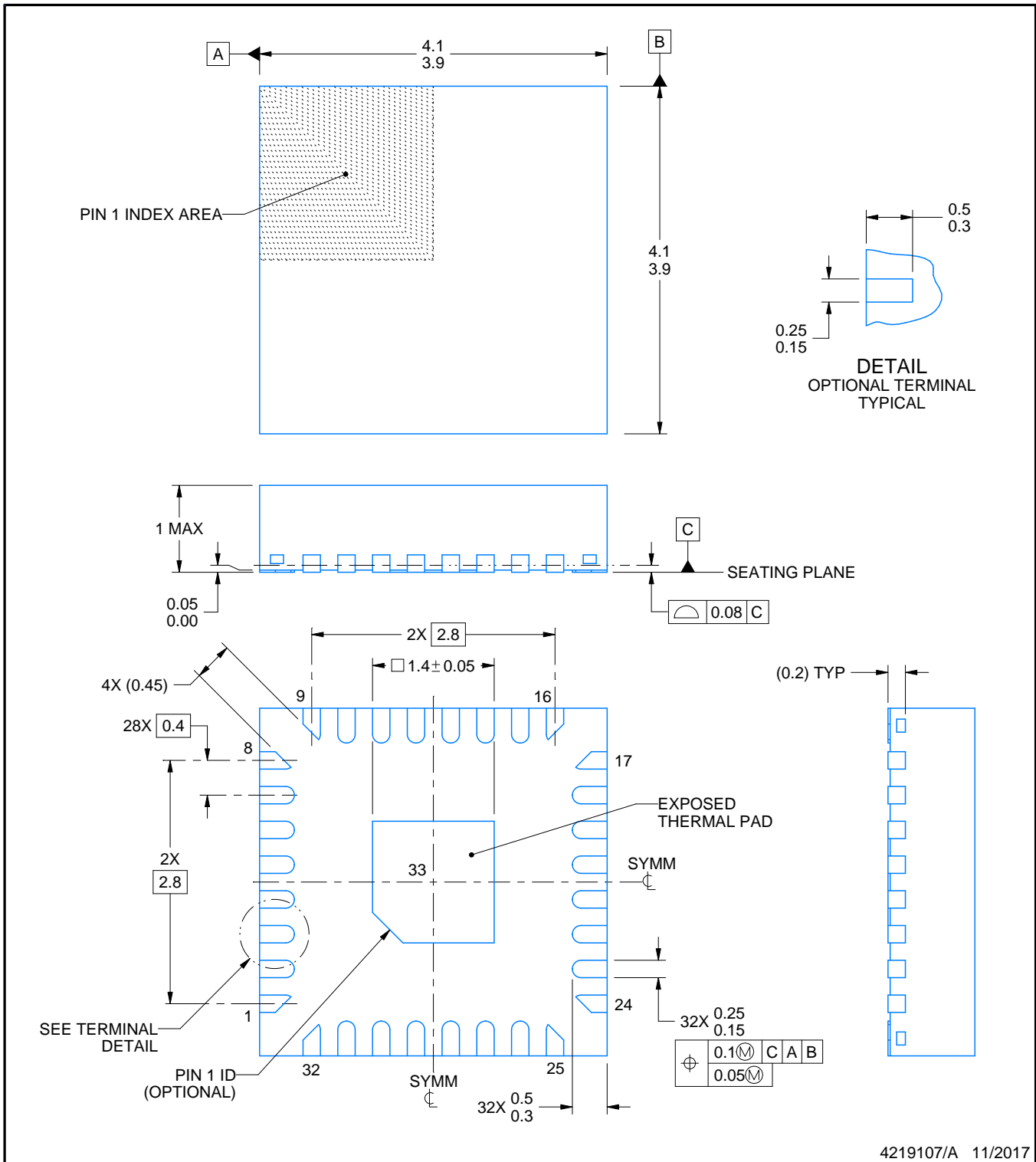
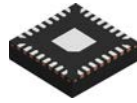

4219107/A 11/2017

NOTES:

1. All linear dimensions are in millimeters. Any dimensions in parenthesis are for reference only. Dimensioning and tolerancing per ASME Y14.5M.
2. This drawing is subject to change without notice.
3. The package thermal pad must be soldered to the printed circuit board for thermal and mechanical performance.

EXAMPLE BOARD LAYOUT

RSM0032A

VQFN - 1 mm max height

PLASTIC QUAD FLATPACK - NO LEAD

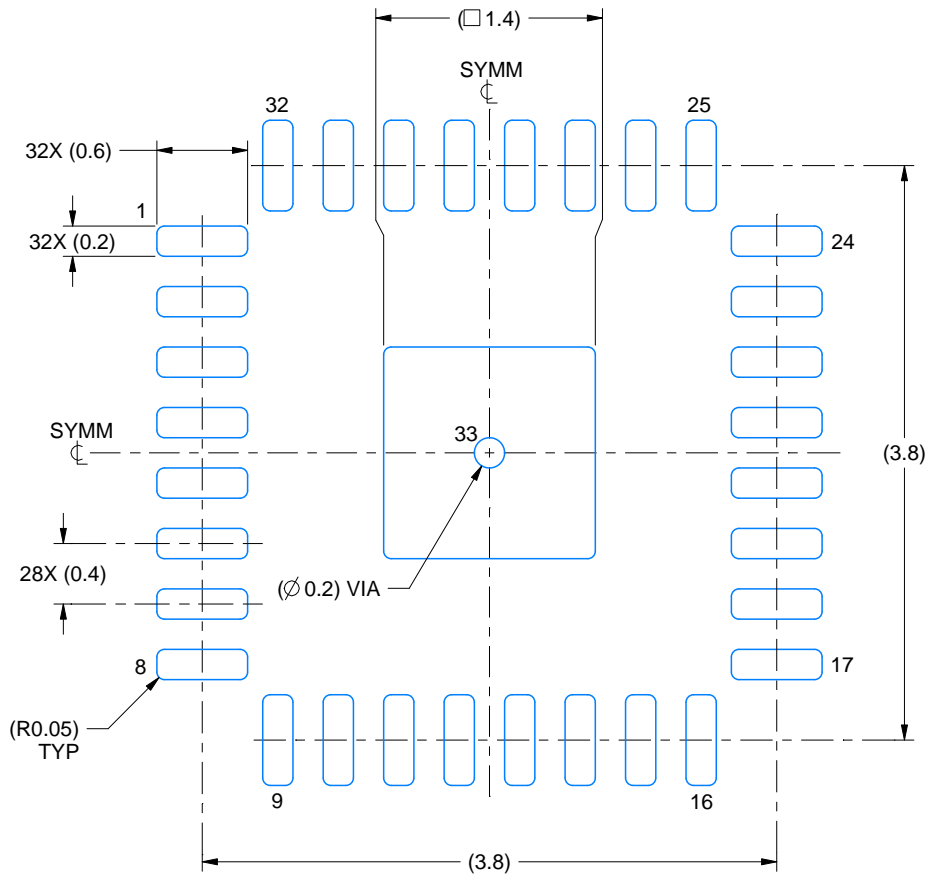

LAND PATTERN EXAMPLE
EXPOSED METAL SHOWN
SCALE:20X

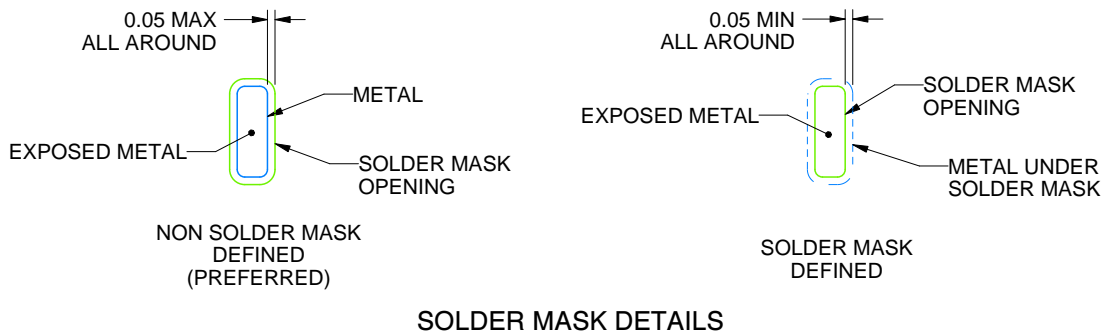

SOLDER MASK DETAILS

4219107/A 11/2017

NOTES: (continued)

- This package is designed to be soldered to a thermal pad on the board. For more information, see Texas Instruments literature number SLUA271 (www.ti.com/lit/sluea271).
- Vias are optional depending on application, refer to device data sheet. If any vias are implemented, refer to their locations shown on this view. It is recommended that vias under paste be filled, plugged or tented.

EXAMPLE STENCIL DESIGN

RSM0032A

VQFN - 1 mm max height

PLASTIC QUAD FLATPACK - NO LEAD

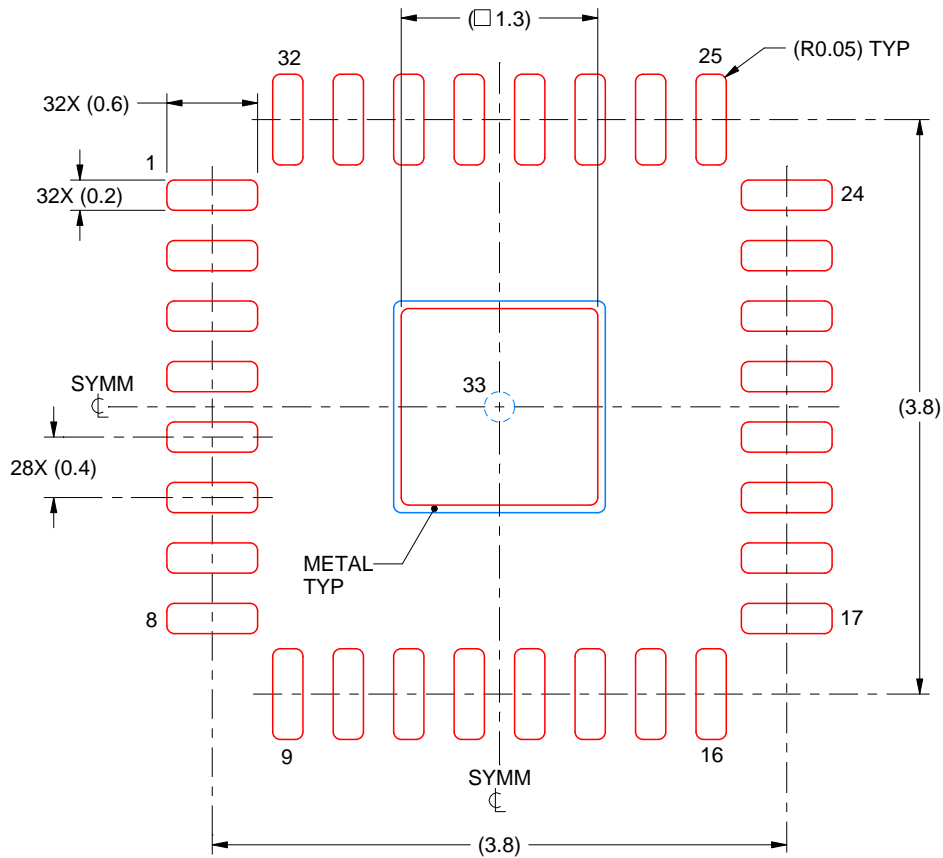

SOLDER PASTE EXAMPLE
BASED ON 0.1 mm THICK STENCIL

EXPOSED PAD 33:
86% PRINTED SOLDER COVERAGE BY AREA UNDER PACKAGE
SCALE:20X

4219107/A 11/2017

NOTES: (continued)

6. Laser cutting apertures with trapezoidal walls and rounded corners may offer better paste release. IPC-7525 may have alternate design recommendations.

IMPORTANT NOTICE AND DISCLAIMER

TI PROVIDES TECHNICAL AND RELIABILITY DATA (INCLUDING DATA SHEETS), DESIGN RESOURCES (INCLUDING REFERENCE DESIGNS), APPLICATION OR OTHER DESIGN ADVICE, WEB TOOLS, SAFETY INFORMATION, AND OTHER RESOURCES "AS IS" AND WITH ALL FAULTS, AND DISCLAIMS ALL WARRANTIES, EXPRESS AND IMPLIED, INCLUDING WITHOUT LIMITATION ANY IMPLIED WARRANTIES OF MERCHANTABILITY, FITNESS FOR A PARTICULAR PURPOSE OR NON-INFRINGEMENT OF THIRD PARTY INTELLECTUAL PROPERTY RIGHTS.

These resources are intended for skilled developers designing with TI products. You are solely responsible for (1) selecting the appropriate TI products for your application, (2) designing, validating and testing your application, and (3) ensuring your application meets applicable standards, and any other safety, security, regulatory or other requirements.

These resources are subject to change without notice. TI grants you permission to use these resources only for development of an application that uses the TI products described in the resource. Other reproduction and display of these resources is prohibited. No license is granted to any other TI intellectual property right or to any third party intellectual property right. TI disclaims responsibility for, and you will fully indemnify TI and its representatives against, any claims, damages, costs, losses, and liabilities arising out of your use of these resources.

TI's products are provided subject to [TI's Terms of Sale](#) or other applicable terms available either on [ti.com](https://www.ti.com) or provided in conjunction with such TI products. TI's provision of these resources does not expand or otherwise alter TI's applicable warranties or warranty disclaimers for TI products.

TI objects to and rejects any additional or different terms you may have proposed.

Mailing Address: Texas Instruments, Post Office Box 655303, Dallas, Texas 75265
Copyright © 2025, Texas Instruments Incorporated