

MAX49140 Evaluation Kit

Evaluates: MAX49140

General Description

The MAX49140 evaluation kit (EV kit) is a fully assembled and tested circuit board that evaluates the MAX49140 30ns, rail-to-rail single supply comparator.

The MAX49140 EV kit comes with a MAX49140AXK/V+ installed that operates off a V_{DD} supply between 2.7V and 5.5V. The MAX49140AXK/V+ is fully specified over -40°C to $+125^{\circ}\text{C}$ automotive temperature range and is AEC-Q100 qualified.

Features

- Fast, 30ns Propagation Delay (10mV Overdrive)
- Low Power 100 μA Supply Current ($V_{DD} = 3\text{V}$)
- Optimized for 3V and 5V Applications
- Rail-to-Rail Input Voltage Range
- Low, 500 μV Offset Voltage
- Internal Hysteresis for Clean Switching
- Output Swing 300mV of Power Rails
- CMOS/TTL-Compatible Outputs
- Small SC70 Package
- AEC-Q100 Qualified
- Proven PCB Layout
- Fully Assembled and Tested

Ordering Information appears at end of data sheet.

Quick Start

Required Equipment

- MAX49140 EV kit
- 2.7V to 5.5V, 100mA DC power supply
- Two precision voltage calibrators
- Two multimeters

Procedure

The EV kit is fully assembled and tested. Follow the steps below to verify board operation before exercising the full features of the MAX49140 devices:

- 1) Set the DC power supply output to 5V. Disable the output.
- 2) Verify that all components except R1/R2/R3 are properly installed.
- 3) Connect the 5V supply positive terminal to V_{DD} test point on the EV kit. Use the first multimeter to measure the supply current (set the multimeter to measure μA current).
- 4) Connect the 5V supply ground terminal to GND test point on the EV kit.
- 5) Connect the second multimeter to measure the voltage on OUT test point on the EV kit.
- 6) Connect the first calibrator output (set to 0.5V) to IN_P test point on the EV kit. Disable the output.
- 7) Connect the second calibrator output (set to 0.1V) to IN_N test point on the EV kit. Disable the output.
- 8) Enable the power supply.
- 9) Enable all the calibrators.
- 10) Verify that the first multimeter reads less than 180 μA .
- 11) Verify that the second multimeter reads 5V \pm 0.3V.
- 12) Disable the calibrators.
- 13) Disable the power supply output.
- 14) Set the first calibrator to 0.1V.
- 15) Set the second calibrator to 0.5V.
- 16) Enable the power supply output.
- 17) Enable the calibrators.
- 18) Verify that the first multimeter reads less than 180 μA .
- 19) Verify that the second multimeter reads 0V \pm 0.3V.

Detailed Description of Hardware

The MAX49140 EV kit provides a proven layout for the MAX49140. The MAX49140 EV kit by default comes with the MAX49140 IC, which is a 30ns, rail-to-rail single supply comparator in 5-pin SC70 package. The EV kit operates from a single 2.7V to 5.5V DC power supply.

Add Extra Input Hysteresis

The MAX49140 has a built-in hysteresis of 1.2mV typical. If the environment noise or signal noise is large, the output may oscillate when the input differential voltage is around the hysteresis. To avoid this issue, the EV kit allows users to add extra hysteresis in addition to the 1.2mV internal hysteresis by adding a positive feedback circuit. R3 and R4 pads are provided for this purpose. The extra hysteresis added is given by the equation below (assuming the high output is close to V_{DD}) and low output is close to ground):

$$\text{HYSTERESIS} = (R3/R4) \times V_{DD}$$

Component List

DESIGNATION	QTY	DESCRIPTION
C1	1	0.1 μ F \pm 10%, 50V X7R ceramic capacitor (0603) Murata GCJ188R71H104KA12
C2	1	1 μ F \pm 10%, 50V X7R ceramic capacitor (0603) TAIYO YUDEN UMK107AB-7105KA

DESIGNATION	QTY	DESCRIPTION
GND	1	Black test point
IN_P, IN_N, OUT	3	White test points
R1, R2, R3	0	Not installed, 0603 resistors
R4	1	0 Ω \pm 5% resistor (0603)
U1	1	MAX49140AXK/V+
V_{DD}	1	Red test point

Ordering Information

PART	TYPE
MAX49140EVKIT#	EV Kit

#Denotes RoHS compliance.

MAX49140 EV Kit Schematic

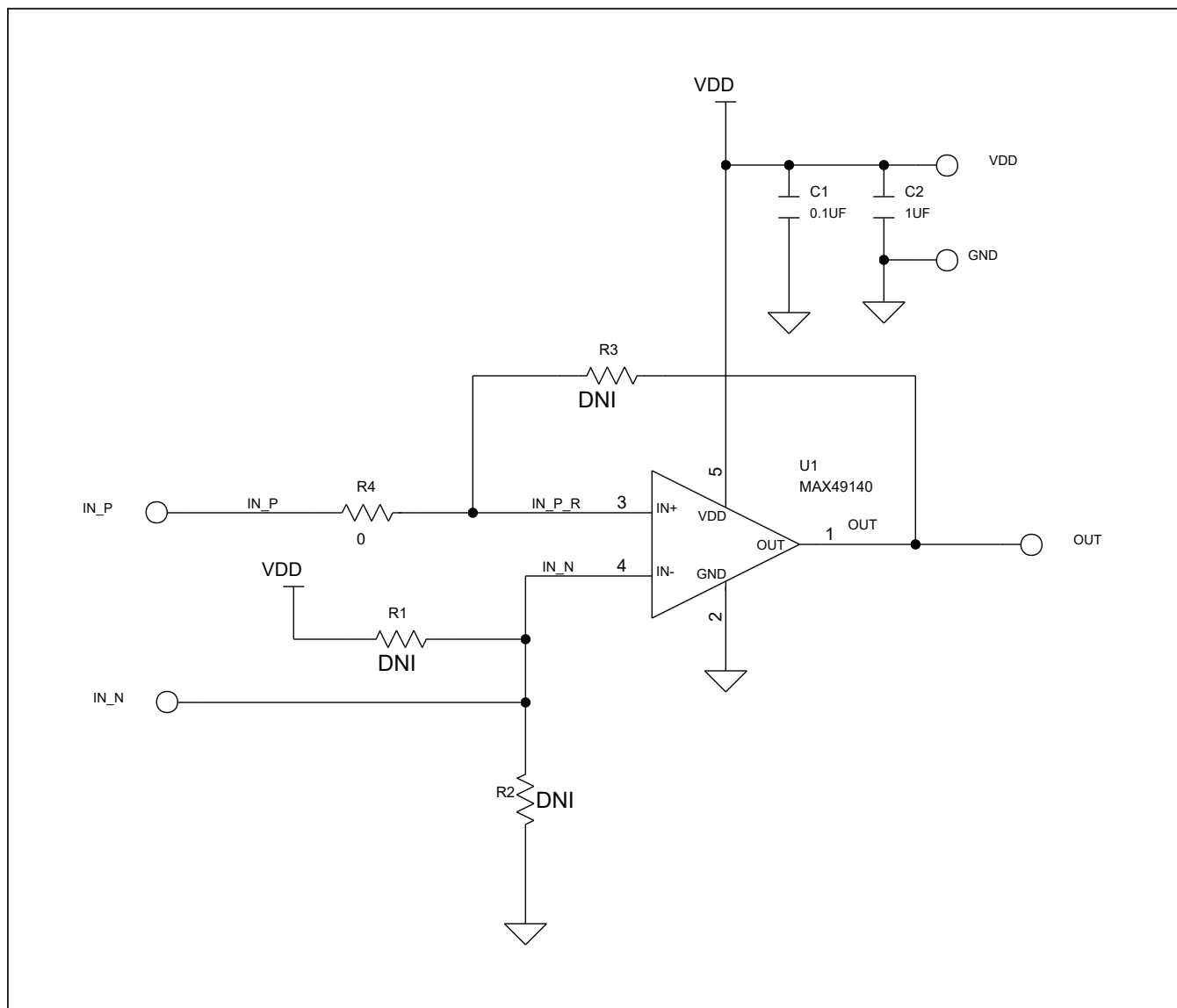

MAX49140 EV Kit PCB Layouts

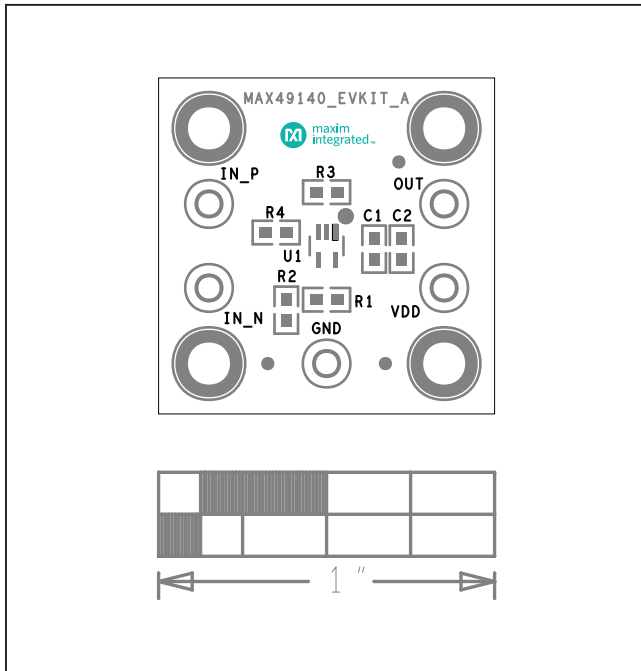

MAX49140 EV Kit Component Placement Guide—Top Silkscreen

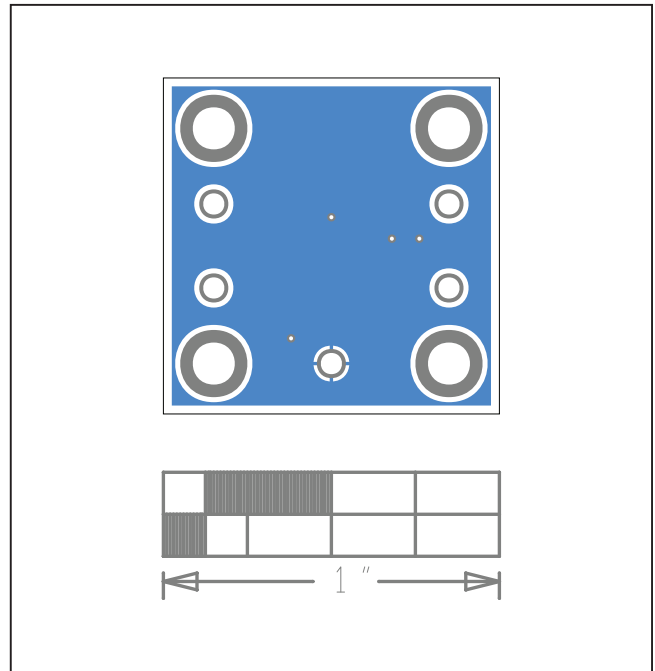

MAX49140 EV Kit PCB Layout—Bottom

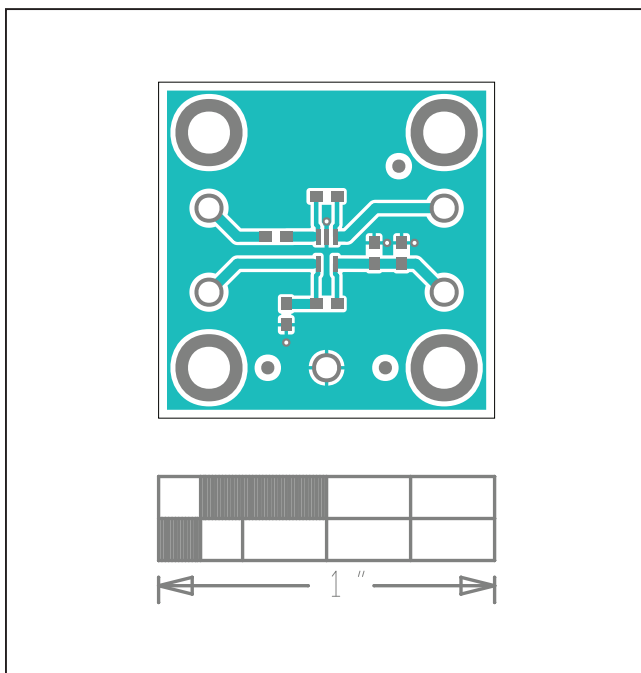

MAX49140 EV Kit PCB Layout—Top

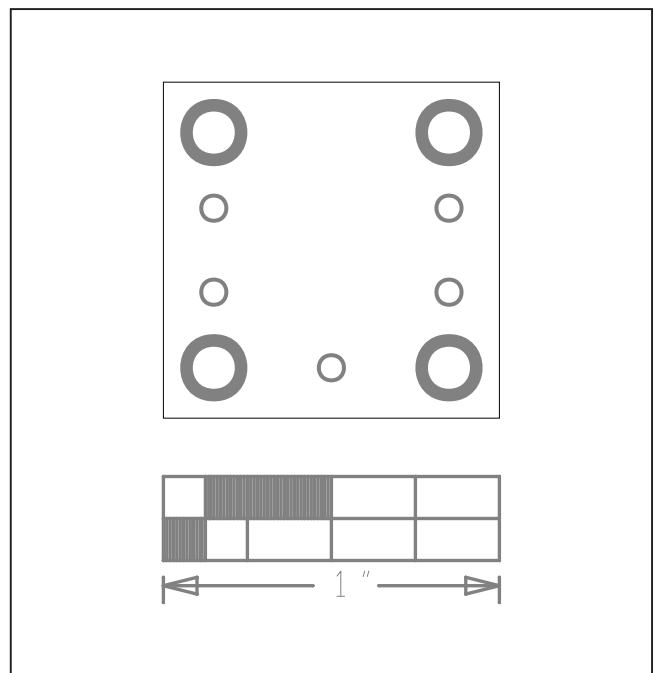

MAX49140 EV Kit Component Placement Guide—Bottom Silkscreen

Revision History

REVISION NUMBER	REVISION DATE	DESCRIPTION	PAGES CHANGED
0	4/20	Initial release	—

For pricing, delivery, and ordering information, please visit Maxim Integrated's online storefront at <https://www.maximintegrated.com/en/storefront/storefront.html>.

Maxim Integrated cannot assume responsibility for use of any circuitry other than circuitry entirely embodied in a Maxim Integrated product. No circuit patent licenses are implied. Maxim Integrated reserves the right to change the circuitry and specifications without notice at any time.