

ANN-MB3

L1/L2/L5 triple-band high precision GNSS antenna

Data sheet



Abstract

This Data sheet describes the ANN-MB3 triple-band L1/L2/L5 active external GNSS antenna that supports all major GNSS systems for maximum position availability. The antenna provides a fast and easy solution for u-blox high precision solution applications with an excellent price-to-performance ratio.

Document information

Title	ANN-MB3	
Subtitle	L1/L2/L5 triple-band high precision GNSS antenna	
Document type	Data sheet	
Document number	UBXDOC-304424225-20333	
Revision and date	R02	16-Dec-2025
Disclosure restriction	C1-Public	

Product status	Corresponding content status	
Functional sample	Draft	For functional testing. Revised and supplementary data will be published later.
In development / prototype	Objective specification	Target values. Revised and supplementary data will be published later.
Engineering sample	Advance information	Data based on early testing. Revised and supplementary data will be published later.
Initial production	Early production information	Data from product verification. Revised and supplementary data may be published later.
Mass production / End of life	Production information	Document contains the final product specification.

This document applies to the following products:

Product name	Type number	Connector type	IN/PCN reference	Product status
ANN-MB3	ANN-MB3-00-00	SMA	N/A	Mass production

u-blox or third parties may hold intellectual property rights in the products, names, logos and designs included in this document. Copying, reproduction, or modification of this document or any part thereof is only permitted with the express written permission of u-blox. Disclosure to third parties is permitted for clearly public documents only.

The information contained herein is provided "as is" and u-blox assumes no liability for its use. No warranty, either express or implied, is given, including but not limited to, with respect to the accuracy, correctness, reliability and fitness for a particular purpose of the information. This document may be revised by u-blox at any time without notice. For the most recent documents and product statuses, visit www.u-blox.com.

Copyright © 2025, u-blox AG.

Contents

Document information.....	2
Contents.....	3
1 Overview.....	4
2 Electrical specifications.....	5
2.1 Patch antenna specification.....	5
2.2 RF front-end specification.....	5
3 Mechanical specifications.....	6
3.1 Mechanical drawing.....	6
3.2 Mechanical data.....	6
3.3 Connector type.....	7
4 Absolute maximum ratings.....	8
5 Antenna characteristics.....	9
5.1 Block diagram.....	9
5.2 Phase center.....	9
5.3 Radiation pattern.....	9
6 Labeling and ordering information.....	11
6.1 Product label.....	11
6.2 Product identifiers.....	11
6.3 Part identification.....	12
6.4 Ordering codes.....	12
7 Qualifications and approvals.....	13
7.1 Safety.....	13
Related documents.....	14
Revision history.....	15
Contact.....	16

1 Overview

The u-blox ANN-MB3 triple-band (L1/L2/L5) active GNSS antenna is designed to reduce time-to-market for modern multi-frequency, multi-constellation, high precision GNSS applications, which require centimeter-level accuracy and a reliable RTK positioning fix even in challenging environments.

ANN-MB3 integrates an additional notch filter (LTE B13) in L1 RF path, and provides the best possible out-of-band interference mitigation. The ANN-MB3 antenna is a perfect solution for the u-blox triple-band F20 high precision platform (e.g. ZED-F20P), and the u-blox F9 high precision products that support L1, L2 and L5 bands.

With ANN-MB3, customers have a reliable, compact, ready-to-use triple-band antenna that streamlines evaluation, minimizes design efforts, and speeds up mass adoption.

2 Electrical specifications

2.1 Patch antenna specification

Parameter	L1 band	L2/L5/E5 band
Frequency ¹	1559 – 1606 MHz	1166 – 1249 MHz
Impedance ¹	50 Ω	50 Ω
Gain ¹	L1: Typical 3.2 dBic	L2: Typical 4.3 dBic L5: Typical 3.8 dBic E5: Typical 5.5 dBic
Efficiency data ¹	L1: Typical 50%	L2: Typical 62% L5: Typical 50% E5: Typical 75%
Axial ratio (Zenith) ¹	Typical 1.0 – 2.5 dB	Typical 1.0 – 2.5 dB
Polarization ¹	RHCP	RHCP

Table 1: ANN-MB3 patch antenna element specification

2.2 RF front-end specification

Parameter	L1 band	L2/L5/E5 band
Frequency	1559 – 1606 MHz	1166 – 1249 MHz
Impedance	50 Ω	50 Ω
LNA gain ^{2,3}	Typical 30.0 ± 3.0 dB	Typical 31.0 ± 3.0 dB
LNA noise figure ^{2,3}	Maximum 3.0 dB	Maximum 3.0 dB
Output VSWR	Maximum 2.0	Maximum 2.0
Cable insertion loss (RG-174, length 5 m)	Typical 6.5 dB	Typical 5.5 dB
Total gain ^{2,4}	Typical 23.5 dB	Typical 25.5 dB
In-band group delay variation	Typical < 8 ns	Typical < 5 ns
Out-of-band rejection min. 100 MHz from GNSS band edges at selected cellular bands	Typical 44 dB (at < 1459 MHz), 47 dB (> 1706 MHz) Typical 56 / 66 / 64 / 47 / 48 / 49 dB (at 698 / 787 / 960 / 1710 / 2170 / 2690 MHz)	Typical 50 dB (at < 1066 MHz), 59 dB (> 1385 MHz) Typical 63 / 53 / 44 / 66 / 62 dB (at 698 / 960 / 1710 / 2170 / 2690 MHz)
Supply voltage ⁵	3.0 – 5.0 V	
Supply current ^{2,5}	Typical 17.0 mA	

Table 2: ANN-MB3 RF front-end specifications

¹ Measured on a ø12 cm ground plane. Measured values include the antenna feed network (hybrid coupler).

² Measured using 5.0 V supply voltage

³ Includes LNA and SAW pre-filter section

⁴ Includes LNA gain and cable insertion loss

⁵ Single supply for L1 and L2/L5/E5 bands

3 Mechanical specifications

3.1 Mechanical drawing

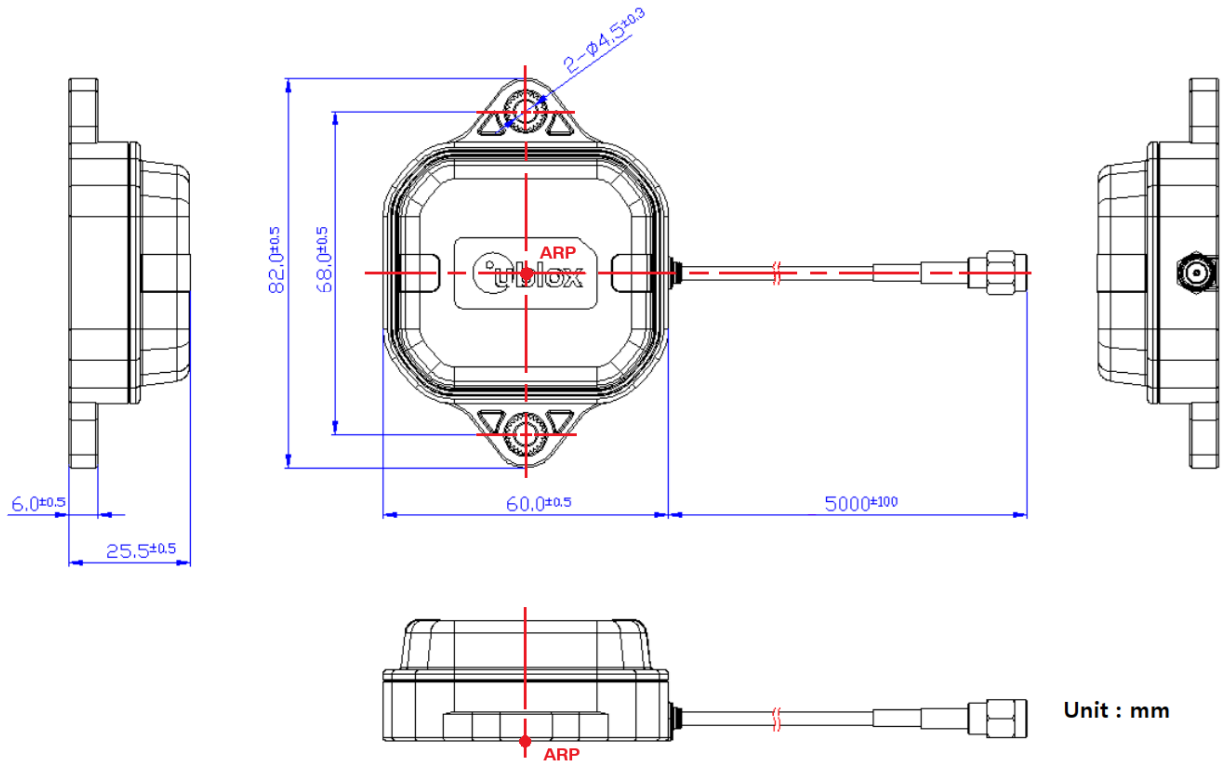

Figure 1: ANN-MB3 mechanical drawing. Dimensions are given in mm.

3.2 Mechanical data

Parameter	Specification
Weight (typical incl. cable)	175 g
Size	82.0(L) x 60.0(W) x 25.5(H) mm
Connector options	SMA (plug)
Cable type, length	RG174, 5.0 meters
Mounting	Magnetic base, fixed installation option (screw mount, 2 x M4 screws)
Housing color	Black

Table 3: ANN-MB3 Mechanical specifications

3.3 Connector type



Figure 2: ANN-MB3 SMA (plug)

4 Absolute maximum ratings

- ⚠ CAUTION. Risk of device damage. Exceeding the absolute maximum ratings may affect the lifetime and reliability of the device or permanently damage it. Do not exceed the absolute maximum ratings.
- ⚠ This product is not protected against overvoltage or reversed voltages. Use appropriate protection to avoid device damage from voltage spikes exceeding the specified boundaries.

Parameter	Symbol	Condition	Min	Max	Units
Power supply voltage	VCC		0.0	10.0	V
Operating temperature	TGP		-40	+85	°C
Storage temperature	TSTG		-40	+85	°C

Table 4: Absolute maximum ratings

5 Antenna characteristics

5.1 Block diagram

A simplified block diagram for ANN-MB3 triple-band antenna is shown in [Figure 3](#). The block diagram is divided into patch antenna element and amplifier sections. The patch antenna element section is specified in [Patch antenna specification](#) and the amplifier section in [RF front-end specification](#). The 5-meter coaxial cable is connected to the amplifier section output.

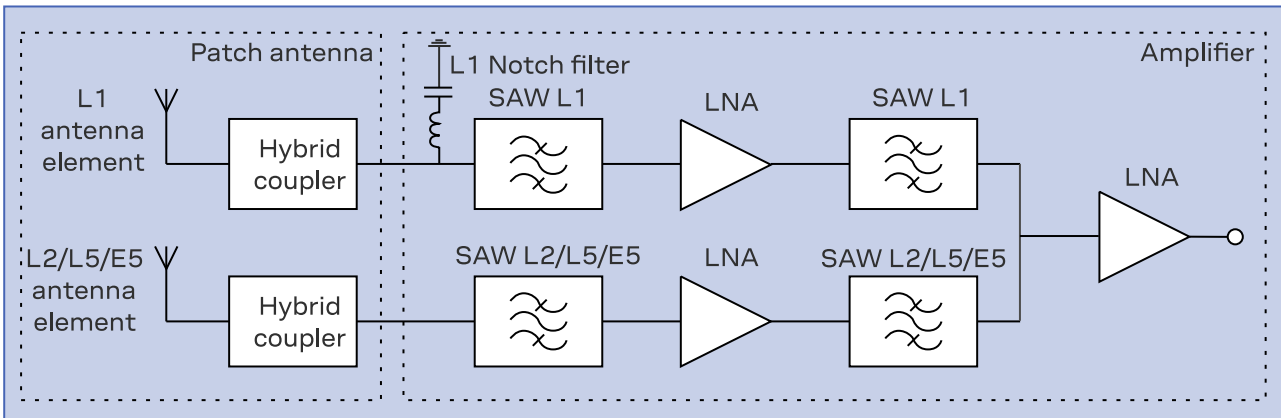

Figure 3: Simplified ANN-MB3 block diagram

5.2 Phase center

Typical values for the absolute antenna phase center offset in L1, L2, L5, and E5b bands are given in . The phase center offset is given in millimeters with respect to the antenna reference point defined in [Mechanical drawing](#). The “North” direction is toward the cable connector. The “Up” direction is normal to the antenna ground plane, toward the patch element.



The phase center offset is measured on a circular ground plane with a 120-millimeter diameter. Any change in ground plane size or shape may affect the phase center offset.

GNSS signal	Frequency (MHz)	Phase center offset horizontal plane (mm)	Up (mm)	Phase center variation over azimuth/elevation (mm)
GPS L1 C/A	1575.42	< 6 in all directions	9.7	< 10 in all directions
GPS L5	1176.45	< 6 in all directions	9.9	< 10 in all directions
GPS L2	1227.60	< 6 in all directions	9.0	< 10 in all directions
Galileo E5b	1207.14 MHz	< 6 in all directions	8.3	< 10 in all directions

Table 5: Typical values for phase center offset and variation relative to antenna reference point (ARP) at all bands. Measured on a circular 120-millimeter ground plane.

5.3 Radiation pattern

The radiation patterns at the L1 and L2/L5/E5 bands are shown in [Figure 5](#) and [Figure 6](#), respectively. The RHCP gain value is the total gain including the passive antenna element, the amplifier section, and the RG174 cable. The planes for the 2-D cuts are H (xy plane), E1 (xz plane), and E2 (yz plane). The coordinate axes are defined in [Figure 4](#).

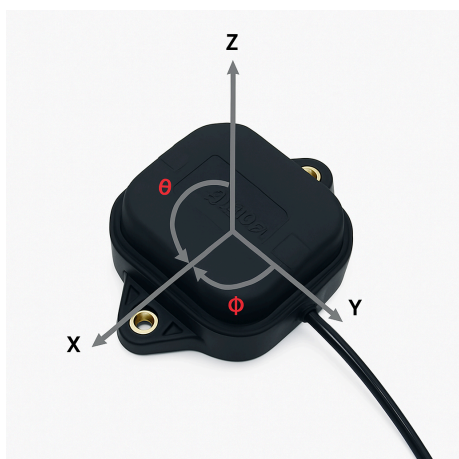

Figure 4: Definition of coordinate axes for radiation pattern plots.

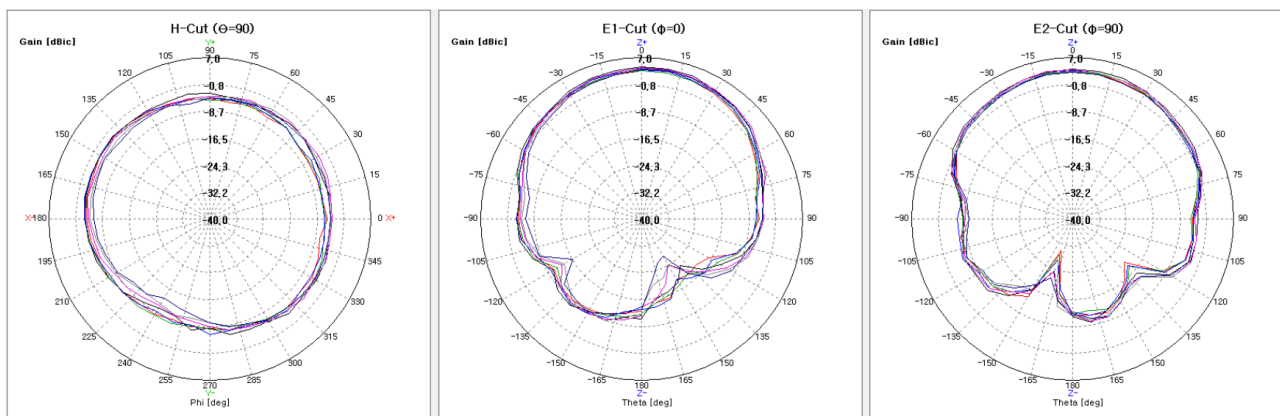

Figure 5: Radiation pattern at the L1 band. The 2-D cuts are measured at 1559 - 1606 MHz.

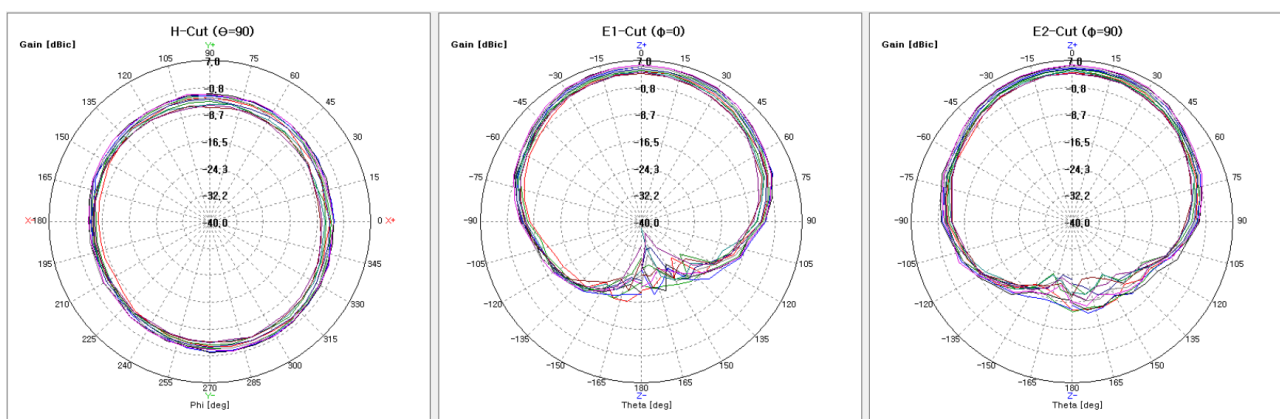

Figure 6: Radiation pattern at the L2/L5/E5 band. The 2-D cuts are measured at 1166 - 1249 MHz.

6 Labeling and ordering information

For more information regarding labeling, package, see the Product packaging reference guide [1].

6.1 Product label

The product information label is found on the underside of the GNSS antenna. The label includes the type number, which provides important information on the product.

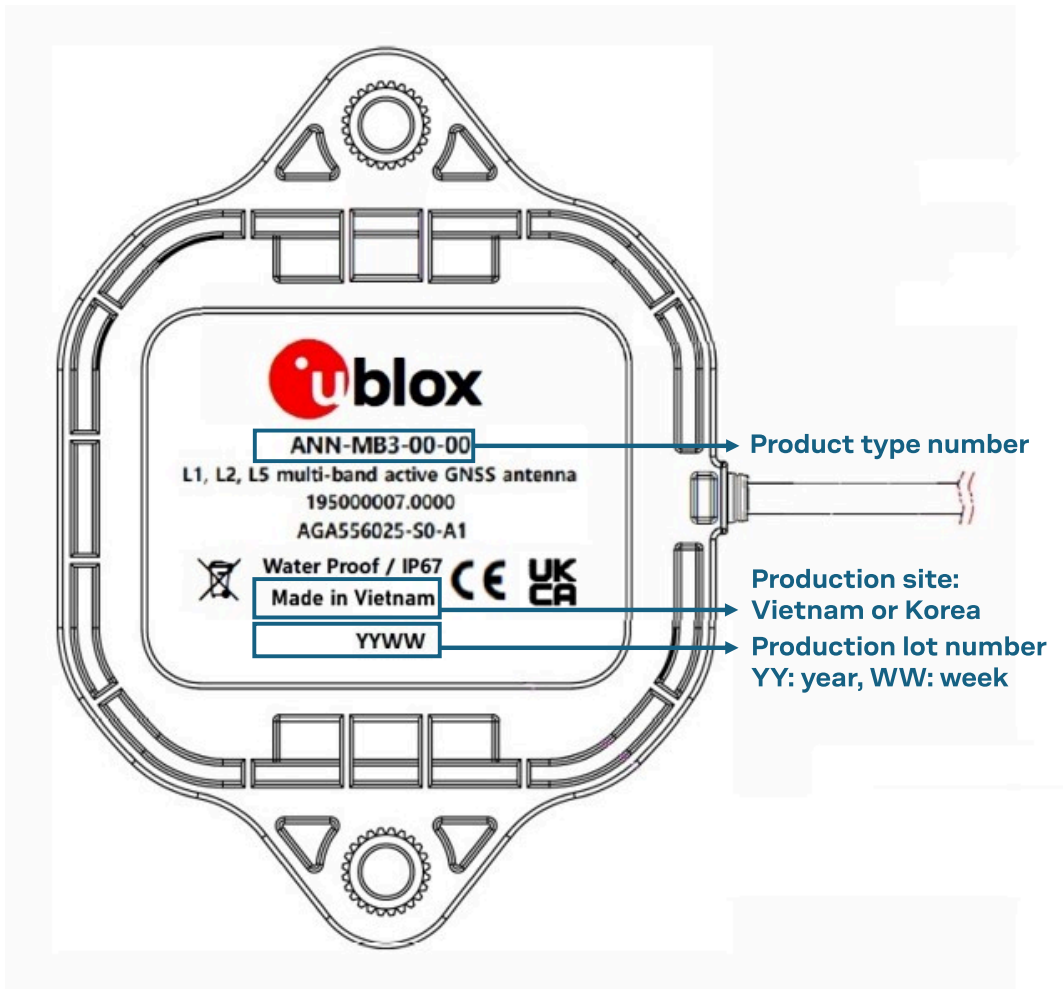

Figure 7: ANN-MB3 triple-band GNSS antenna product label.

6.2 Product identifiers

The ANN-MB3 labels feature three identifiers for the product: product name, ordering code and type number. The product name is used across all u-blox products in documentation such as this Data sheet and is independent of packaging and product grade. The ordering code specifies the major product version and product grade and the type number additionally includes the hardware and firmware versions.

Table 6 provides product code formats

Format	Structure	Product code
Product name	PPP-GVY	ANN-MB3

Format	Structure	Product code
Ordering code	PPP-GVY-NN	ANN-MB3-00
Type number	PPP-GVY-NN-XX	ANN-MB3-00-00

Table 6: Product code formats

6.3 Part identification

The parts of the product code are explained in [Table 7](#).

Identifier	Format	Example
PPP	Product family	ANN
GV	Product generation	MB: Multi-band
Y	Product variant	3: L1/L2/L5/E5 high precision
NN	Major product version	Connector type: 00 = SMA connector
XX	Revision	Hardware and firmware versions

Table 7: Description of product label

6.4 Ordering codes

Ordering code	Product
ANN-MB3-00	L1/L2/L5 triple band active GNSS antenna, 5 m cable, SMA (plug) connector Single units

Table 8: Product ordering codes

7 Qualifications and approvals

Type	Description
Environmental	
RoHS compliance	Yes
ESD circuit protection	±15 kV (IEC61000-4-2)
Ingress protection (IP) rating	IP67 (dustproof and protected from temporary water immersion to 1 meter)
Humidity	95%RH, 60 °C, 96 hours
Vibration	MIL-STD-810G, Method 514.7 Vibration
Type approvals	
European RED certification (CE)	Declaration of Conformity (DoC) is available on the u-blox website .
UK conformity assessment (UKCA)	Yes

Table 9: Qualifications and approvals

7.1 Safety

ANN-MB3 shall be supplied by a power supply complying with the requirements of PS1 according to safety standard EN 62368-1 <https://webstore.iec.ch/publication/27412>.

Related documents

[1] Product packaging reference guide [UBX-14001652](#)

For product change notifications and regular updates of u-blox documentation, register on our website, <https://www.u-blox.com>.

Revision history

Revision	Date	Comments
R01	15-Sept-2025	Initial release
R02	16-Dec-2025	Updated product status to Mass production. Added Phase center section. Added CE approval information and revised product label figure. Updated the total gain in the RF front-end specification table. Editorial changes throughout the document.

Contact

u-blox AG

Address: Zürcherstrasse 68
8800 Thalwil
Switzerland

For further support and contact information, visit us at www.u-blox.com/support.