

This document is the property of Amphenol Corporation and is delivered on the express condition that is not to be disclosed, reproduced or used, in whole or in part, for manufacture or sale by anyone other than Amphenol Corporation without its prior consent, and that no right is granted to disclose or to use any information in this document.

The marking on this product doesn't contain environmental hazardous materials per Material Specification 55-00259 for Sony GP compliant or per directive 2002/95/EC for RoHS compliant.



ORIGINAL

REVISIONS				
SYM	ECN No.	DESCRIPTION	DATE	APPROVED
A		RELEASE FOR RoHS	01/10/2005	Bodhi Chih
B	NE-09102	CHANGE VENDOR	06/16/2009	Roger Tsai
C	NE-12098	UPDATE DRAWING	09/06/2012	Roger Tsai
D	NE-17061	MODIFIED PACKAGING	03/30/2017	Roger Tsai



G800 W 556 XXX EU	2 x 40 = 80	101.6	99.06
G800 W 557 XXX EU	2 x 39 = 78	99.06	96.52
G800 W 558 XXX EU	2 x 38 = 76	96.52	93.98
G800 W 559 XXX EU	2 x 37 = 74	93.98	91.44
G800 W 560 XXX EU	2 x 36 = 72	91.44	88.90
G800 W 561 XXX EU	2 x 35 = 70	88.90	86.36
G800 W 562 XXX EU	2 x 34 = 68	86.36	83.82
G800 W 563 XXX EU	2 x 33 = 66	83.82	81.28
G800 W 564 XXX EU	2 x 32 = 64	81.28	78.74
G800 W 565 XXX EU	2 x 31 = 62	78.74	76.20
G800 W 566 XXX EU	2 x 30 = 60	76.20	73.66
G800 W 567 XXX EU	2 x 29 = 58	73.66	71.12
G800 W 568 XXX EU	2 x 28 = 56	71.12	68.58
G800 W 569 XXX EU	2 x 27 = 54	68.58	66.04
G800 W 570 XXX EU	2 x 26 = 52	66.04	63.50
G800 W 571 XXX EU	2 x 25 = 50	63.50	60.96
G800 W 572 XXX EU	2 x 24 = 48	60.96	58.42
G800 W 573 XXX EU	2 x 23 = 46	58.42	55.88
G800 W 574 XXX EU	2 x 22 = 44	55.88	53.34
G800 W 575 XXX EU	2 x 21 = 42	53.34	50.80
G800 W 576 XXX EU	2 x 20 = 40	50.80	48.26
G800 W 577 XXX EU	2 x 19 = 38	48.26	45.72
G800 W 578 XXX EU	2 x 18 = 36	45.72	43.18
G800 W 579 XXX EU	2 x 17 = 34	43.18	40.64
G800 W 580 XXX EU	2 x 16 = 32	40.64	38.10
G800 W 581 XXX EU	2 x 15 = 30	38.10	35.56
G800 W 582 XXX EU	2 x 14 = 28	35.56	33.02
G800 W 583 XXX EU	2 x 13 = 26	33.02	30.48
G800 W 584 XXX EU	2 x 12 = 24	30.48	27.94
G800 W 585 XXX EU	2 x 11 = 22	27.94	25.40
G800 W 586 XXX EU	2 x 10 = 20	25.40	22.86
G800 W 587 XXX EU	2 x 9 = 18	22.86	20.32
G800 W 588 XXX EU	2 x 8 = 16	20.32	17.78
G800 W 589 XXX EU	2 x 7 = 14	17.78	15.24
G800 W 590 XXX EU	2 x 6 = 12	15.24	12.70
G800 W 591 XXX EU	2 x 5 = 10	12.70	10.16
G800 W 592 XXX EU	2 x 4 = 8	10.16	7.62
G800 W 593 XXX EU	2 x 3 = 6	7.62	5.08
G800 W 594 XXX EU	2 x 2 = 4	5.08	2.54
<b>PART NUMBER</b>	<b>NO. OF CIRCUIT</b>	<b>A</b>	<b>B</b>

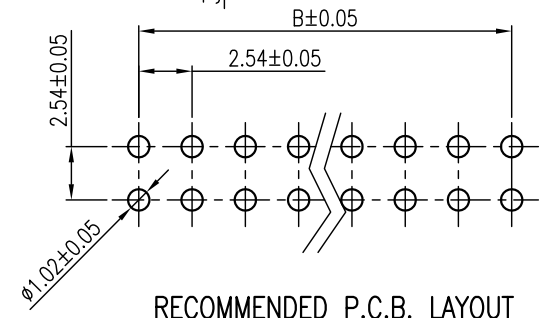
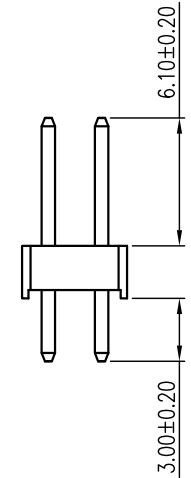
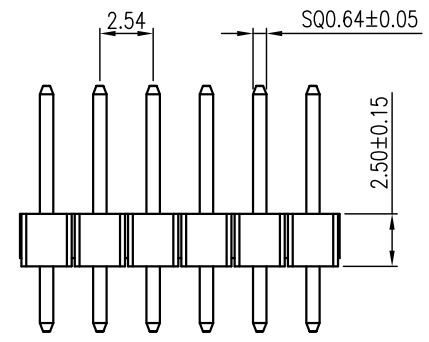
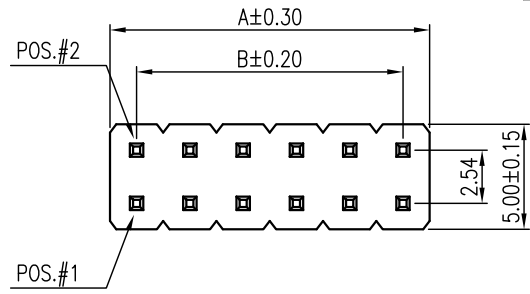

- NOTES:**
- INSULATOR: NYLON-6T, UL 94V-0, COLOR- BLACK
  - CONTACT: BRASS, SELECTIVE GOLD PLATED ON CONTACT AREA, G/F OR TIN PLATED ON SOLDERING AREA (LEAD FREE)
  - THIS PRODUCT DOESN'T CONTAIN ENVIRONMENTAL HAZARDOUS MATERIALS PER DIRECTIVE 2002/95/EC FOR RoHS.

PART NO. G800WXXXXXEU  
 NO. OF CIRCUIT — CONTACT FINISH  
 005: 15 u" GOLD MIN.  
 010: 30 u" GOLD MIN.  
 018: FULL GOLD FLASH  
 025: 5 u" GOLD MIN.  
 035: 3 u" OVER ALL GOLD MIN.

TOLERANCE	APPROVALS	DATE	TITLE		Amphenol®	
X. ±0.30	DRAWN Aqua Chou	03/30/2017	G800 SERIES, DUAL ROWS HEADER 2.54MM PITCH STRAIGHT PCB MOUNT		Amphenol Corporation Amphenol Taiwan Corporation	
X.X ±0.20	CHECKED Roger Tsai	03/30/2017				
X.XXX ±0.10	APPROVED Roger Tsai	03/30/2017				
ANGULAR ±1°	DWG TYPE CUST DWG	PROJECT CODE HEAD				
UNLESS OTHERWISE SPECIFIED			UNIT mm	SIZE A3	PART No. G800WXXXXXEU	
			SCALE NA	SHEET 1 OF 2	DWG No. G800WXXXXXEU_2	REV. D

This document is the property of Amphenol Corporation and is delivered on the express condition that is not to be disclosed, reproduced or used, in whole or in part, for manufacture or sale by anyone other than Amphenol Corporation without its prior consent, and that no right is granted to disclose or to use any information in this document.

The marking on this product doesn't contain environmental hazardous materials per Material Specification 55-00259 for Sony GP compliant or per directive 2002/95/EC for RoHS compliant.



ORIGINAL



REVISIONS				
SYM	ECN No.	DESCRIPTION	DATE	APPROVED
A		RELEASE FOR RoHS	01/10/2005	Bodhi Chih
B	NE-09102	CHANGE VENDOR	06/16/2009	Roger Tsai
C	NE-12098	UPDATE DRAWING	09/06/2012	Roger Tsai
D	NE-17061	MODIFIED PACKAGING	03/30/2017	Roger Tsai

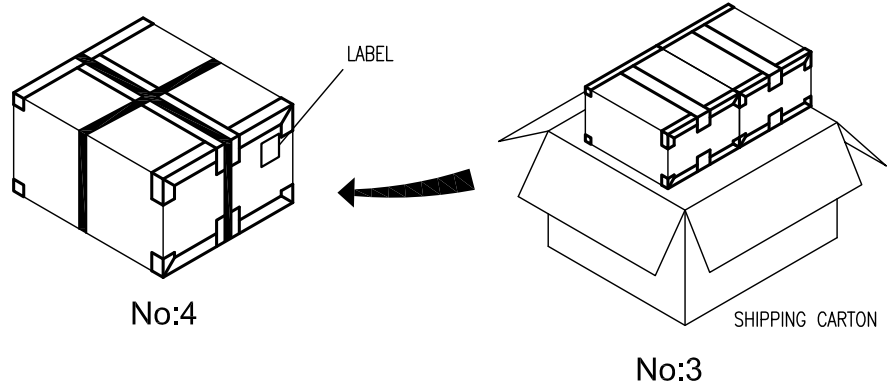
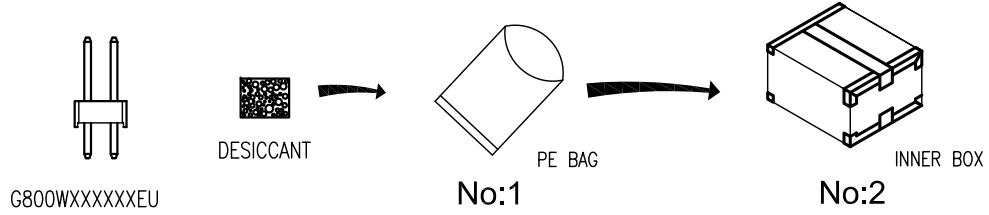

- NOTES:
1. INNER BOX SIZE : 215 X 175 X 150 mm
  2. SHIPPING CARTON SIZE : 370 X 230 X 175 mm

POS.	PCS/BAG	BAG/ INNER BOX	N.W.(kg) REF	G.W.(kg) REF	QUANTITY (PCS)
2X2P	2000	5	2.7	4.0	20000
2X3P	2000	5	4.1	5.3	20000
2X4P	2000	3	3.3	4.5	12000
2X5P	1000	6	4.1	5.3	12000
2X6P	1000	4	3.3	4.5	8000
2X7P	500	6	2.9	4.1	6000
2X8P	300	8	2.6	3.8	4800
2X9P	300	6	2.2	3.5	3600
2X10P	300	6	2.5	3.7	3600
2X11P	300	6	2.7	4.0	3600
2X12P	300	6	3.0	4.2	3600
2X13P	300	6	3.2	4.4	3600
2X14P	200	6	2.3	3.5	2400
2X15P	200	6	2.5	3.7	2400
2X16P	200	6	2.6	3.9	2400
2X17P	200	6	2.8	4.0	2400
2X18P	200	6	3.0	4.2	2400
2X19P	200	6	3.1	4.3	2400
2X20P	200	6	3.3	4.5	2400
2X21P	200	6	3.5	4.7	2400
2X22P	150	6	2.7	3.9	1800
2X23P	150	6	2.8	4.1	1800
2X24P	150	6	3.0	4.2	1800
2X25P	150	6	3.1	4.3	1800
2X26P	150	6	3.2	4.4	1800
2X27P	100	6	2.2	3.5	1200
2X28P	100	6	2.3	3.5	1200
2X29P	100	6	2.4	3.6	1200
2X30P	100	6	2.5	3.7	1200
2X31P	100	6	2.6	3.8	1200
2X32P	100	6	2.6	3.9	1200
2X33P	100	6	2.7	4.0	1200
2X34P	100	6	2.8	4.0	1200
2X35P	100	6	2.9	4.1	1200
2X36P	100	6	3.0	4.2	1200
2X37P	100	6	3.1	4.3	1200
2X38P	100	6	3.1	4.3	1200
2X39P	100	6	3.2	4.4	1200
2X40P	100	6	3.3	4.5	1200

TOLERANCE		APPROVALS		DATE	TITLE		PART No.	
X.		DRAWN	Aqua Chou	03/30/2017	G800 SERIES SINGLE, DUAL ROWS HEADER 2.54MM PITCH STRAIGHT PCB MOUNT		Amphenol®	
X.X	±0.30	CHECKED	Roger Tsai	03/30/2017			Amphenol Corporation	
X.XX	±0.20	APPROVED	Roger Tsai	03/30/2017			Amphenol Taiwan Corporation	
X.XXX	±0.10				UNIT	mm	SIZE	A3
ANGULAR	±1°				SCALE	NA	SHEET	2 OF 2
UNLESS OTHERWISE SPECIFIED		DWG TYPE		PROJECT CODE	DWG No.		REV.	
		CUST DWG		HEAD	G800WXXXXXEU_2		D	