



# PNX4008

## Nexperia mobile multimedia application processor

Optimized for use in smart/feature mobile phone applications, this ARM-based processor delivers unprecedented multimedia performance. It integrates dedicated accelerators that support advanced features, including high-resolution imaging, real-time full frame rate video recording/playback, video telephony, enhanced music, 3D gaming, security, and more.

### Key features

- Unique architecture for unprecedented multimedia performance
  - ARM9 processor in 90-nm CMOS technology running at 208 MHz
  - Dedicated accelerators for video, audio, graphics, and security subsystems to provide optimized performance and reduce power consumption
- High-resolution imaging
  - Still image capture up to 4 Megapixels
- Video record/playback
  - Simultaneous H.263, MPEG-4 encode/decode of streams up to CIF resolution at 30 fps
- Video telephony
  - Full-duplex, low-latency video encode/decode mode
- Enhanced audio/music
  - Dedicated DSP for all audio activities
  - Integrated stereo DACs and ADCs
- 3D gaming
  - OpenGL-ES compliant 3D graphics accelerator
- Security
  - PKI, Symmetric and Hash Coprocessors
  - Random Number Generator with fuses for key generation
- Space-saving LFBGA320 package and Package-on-Package VFBGA353

The Nexperia multimedia application processor PNX4008 provides advanced video, imaging, and audio functions in feature-rich mobile handsets and

smartphones. Based on an ARM9 RISC processor that supports open operating systems, the PNX4008 uses a unique architecture to deliver unprecedented multimedia performance. The ARM processor, manufactured in 90-nm CMOS technology, the resulting device delivers optimum performance with very low power consumption, runs at 208 MHz and is accelerated by dedicated video, audio, graphics, and security subsystems. The result is optimized performance with very low power consumption.

### CPU subsystem

The CPU subsystem combines a 208 MHz ARM926-EJ processor with dedicated 32k instruction and 32k data caches. It also includes a memory management unit (MMU), a debug port with an embedded trace module (and embedded trace buffer), and a DMA controller.

### Video subsystem

The video subsystem provides high-performance support for still and video images. It includes an encode acceleration JPEG decoder, an MPEG-4/H.263 video encoder/decoder, and a graphics accelerator, plus LCD and camera interfaces.

The JPEG decoder handles resolutions up to 4 Megapixels, offers baseline ISO/IEC 10908-1 JPEG compliance (DCT sequential) and accepts inputs in JFIF 1.02 file format with

# PHILIPS

marker handling. It uses 8-bit samples for each color component (YUV 4:4:4/4:2:2/4:1:1/4:2:0/4:0:0) and supports component interleaved and single frames. For Huffman coding it uses two AC and two DC tables.

The MPEG-4/H.263 encoder/decoder supports planar and semi-planar YUV 4:2:0 inputs and outputs, and works with all resolutions up to CIF (352x288) running at 30 fps. The encoder/decoder is fully MPEG-4 compliant, compatible with simple profile (levels 0 through 3) and baseline H.263 (short header).

The video subsystem can interface to a camera with a resolution of up to 4 Megapixels, receiving inputs in YUV (4:2:2) format. The video subsystem can also interface to an LCD with up to QVGA 18-bit RGB resolution and a refresh rate up to 60 fps. For systems with an embedded LCD controller and frame memory, there is an 8/9-bit parallel I80 display interface. An integrated display update master acts independently to refresh the display, making it possible to fetch display data from the DRAM and write it to the display. Sync Logic prevents the display from tearing.

### Audio subsystem

The audio subsystem combines a fully dedicated audio DSP with integrated stereo DACs and ADCs to provide superior sound capabilities. The audio DSP can operate independently from the ARM CPU and can reference embedded RAM memories for full audio flexibility, including upgrades for future technologies. For stereo sound, there are two integrated stereo DACs and one stereo ADC. There are also two PCM interfaces, carrying 8- or 16-kHz sample-rate voice channels.

### Security subsystem

The security subsystem consists of three coprocessors, a random number generator, and a unique secret crypto key that uses embedded fuses. The PKI coprocessor supports RSA, ECC, DSS, and DH. The symmetric coprocessor supports DES, 3DES, and AES, while the Hash coprocessor supports SHA-1 and MD5.

### 3D subsystem

The 2D/3D graphics accelerator complies with OpenGL ES 1.0 APIs. Running at 104 MHz, it delivers a typical performance of 150 Megapixels per second and 1.25 million polygons per second.

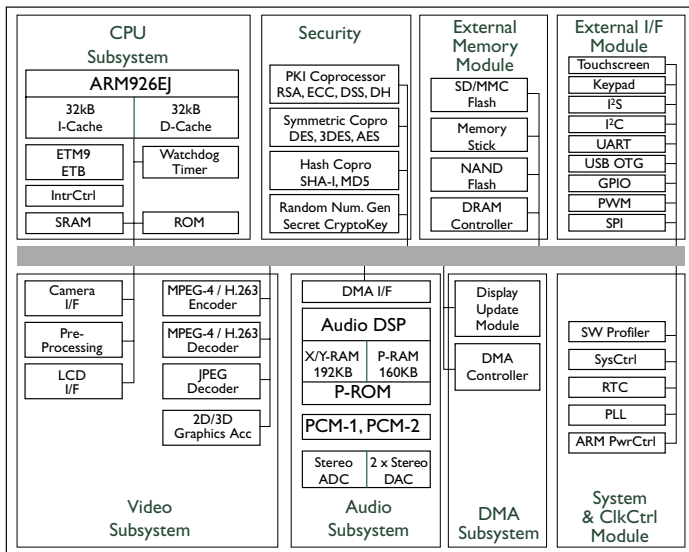

PNX4008 block diagram

### Philips Semiconductors

Philips Semiconductors is one of the world's top semiconductor suppliers, with 20 manufacturing and assembly sites and a sales organization that delivers in 60 countries. For a complete up-to-date list of our sales offices please visit our website <http://www.semiconductors.philips.com/sales>

### ©2006 Koninklijke Philips Electronics N.V.

All rights reserved. Reproduction in whole or in part is prohibited without the prior written consent of the copyright owner. The information presented in this document does not form part of any quotation or contract, is believed to be accurate and reliable and may be changed without notice. No liability will be accepted by the publisher for any consequence of its use. Publication thereof does not convey nor imply any license under patent- or other industrial or intellectual property rights.

date of release: January 2006  
document order number: 9397 750 1541 I

Printed in the Netherlands

