

REVISION		
REV	DESCRIPTION	DATE
NC	INITIAL RELEASE PER DCR No. T31878	24JUN2003
NC1	REVISED CD PER ECO-19-005397	4/8/2019

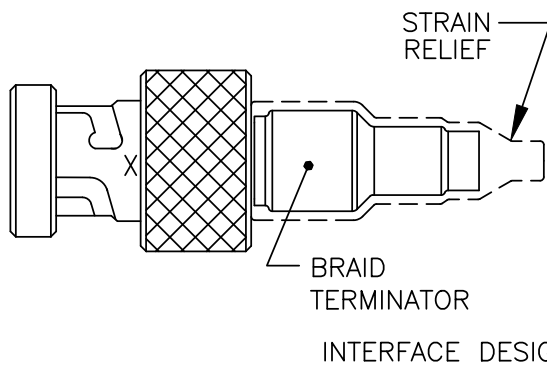

PLUG CONNECTOR KIT, TYPICAL

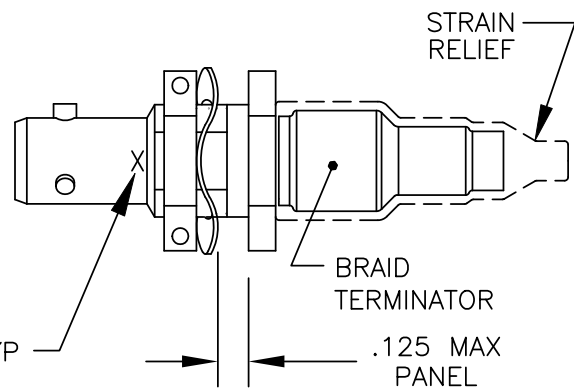

JACK CONNECTOR KIT, TYPICAL

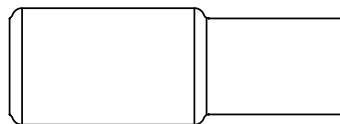

BRAID TERMINATOR
B-070-84

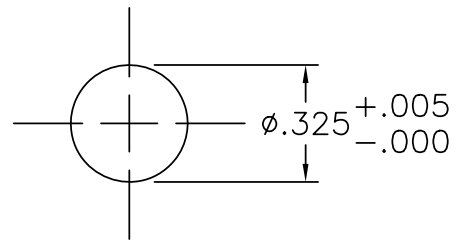

JACK MOUNTING HOLE
(SUGGESTED)

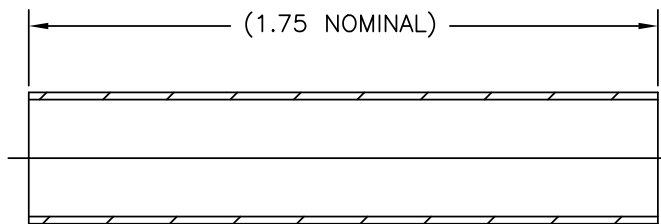

STRAIN RELIEF (UNRECOVERED): D-600-0033

© 2019 TE Connectivity Corporation. All Rights Reserved.

Raychem Databus CUSTOMER DRAWING

UNLESS OTHERWISE SPECIFIED DIMENSIONS ARE INCHES. METRIC DIMENSIONS ARE IN BRACKETS. DECIMAL TOLERANCES .XXX ± 0.005 [0.13 mm] .XX ± 0.010 [0.25 mm] .X ± 0.020 [0.50 mm] ANGLE TOLERANCE .X ± 0.5 DEG. WEIGHT SEE NOTES CAD FILE T31878A.dwg	DRAWN T RATZLAFF	DATE 24JUN2003		
	MATERIAL 		TITLE DATA BUS CONNECTOR KIT, LIGHTWEIGHT, LOW OUTGASSING	
FINISH 		SIZE A	CAGE CODE 06090	DWG. NO. DK-621-L933/L940(-XX)
THIRD ANGLE PROJECTION 		DO NOT SCALE THIS DRAWING		SHEET 1 OF 3

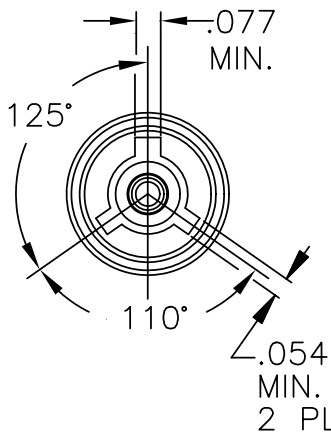

FIGURE 1
PLUG
INTERFACE
"A"

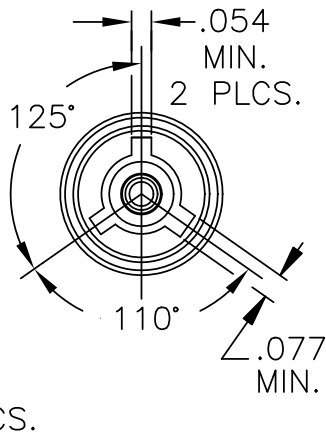

FIGURE 3
PLUG
INTERFACE
"B"

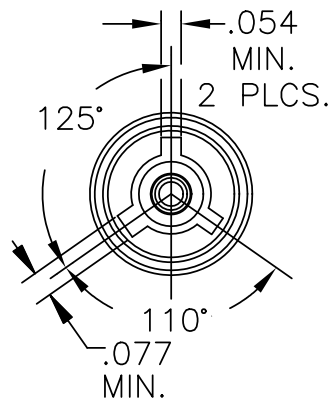

FIGURE 5
PLUG
INTERFACE
"C"

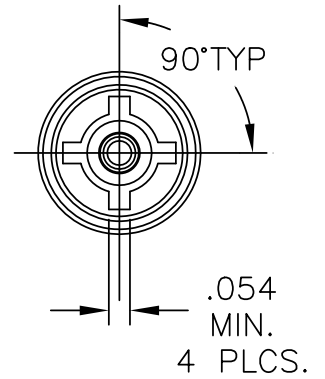

FIGURE 7
PLUG
INTERFACE
"D"

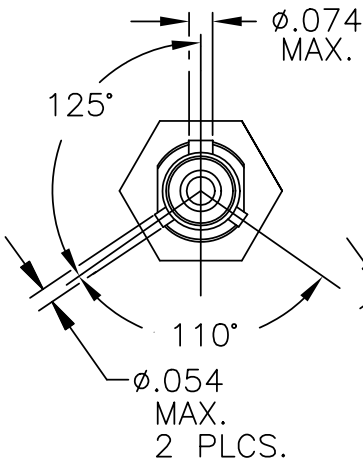

FIGURE 2
JACK
INTERFACE
"A"

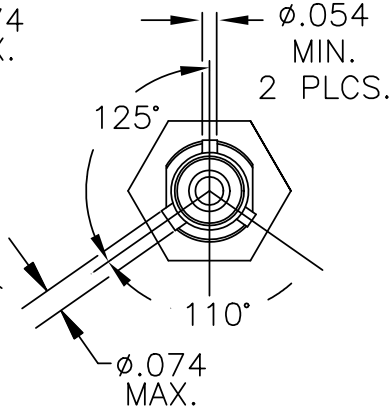

FIGURE 4
JACK
INTERFACE
"B"

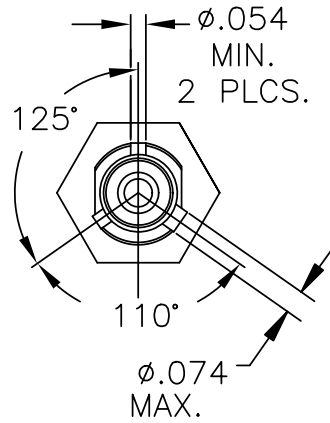

FIGURE 6
JACK
INTERFACE
"C"

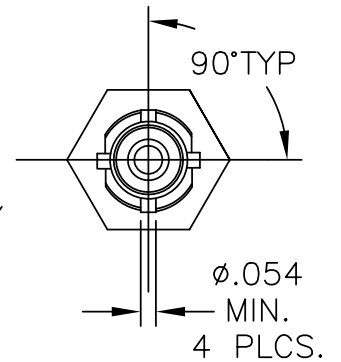

FIGURE 8
JACK
INTERFACE
"D"

NOTES:

1. MAJOR KEY ORIENTATION WITH RESPECT TO FLATS IS NOT CONTROLLED.

Raychem Databus CUSTOMER DRAWING



TE Connectivity

DRAWN T RATZLAFF	DATE 24JUN2003	SIZE A	CAGE CODE 06090	DWG. NO. DK-621-L933/L940(-XX)	REV NC1
CAD FILE T31878A.dwg		DO NOT SCALE THIS DRAWING			SHEET 2 OF 3

PART No.	CONNECTOR	CONTACT	INTERFACE
DK-621-L933	PLUG	—	A
DK-621-L933-1P	PLUG	PIN	A
DK-621-L933-1S	PLUG	SOCKET	A
DK-621-L934	JACK	—	A
DK-621-L934-1P	JACK	PIN	A
DK-621-L934-1S	JACK	SOCKET	A
DK-621-L935	PLUG	—	B
DK-621-L935-2P	PLUG	PIN	B
DK-621-L935-2S	PLUG	SOCKET	B
DK-621-L936	JACK	—	B
DK-621-L936-2P	JACK	PIN	B
DK-621-L936-2S	JACK	SOCKET	B

PART No.	CONNECTOR	CONTACT	INTERFACE
DK-621-L937	PLUG	—	C
DK-621-L937-3P	PLUG	PIN	C
DK-621-L937-3S	PLUG	SOCKET	C
DK-621-L938	JACK	—	C
DK-621-L938-3P	JACK	PIN	C
DK-621-L938-3S	JACK	SOCKET	C
DK-621-L939	PLUG	—	D
DK-621-L939-4P	PLUG	PIN	D
DK-621-L939-4S	PLUG	SOCKET	D
DK-621-L940	JACK	—	D
DK-621-L940-4P	JACK	PIN	D
DK-621-L940-4S	JACK	SOCKET	D

1. MATERIAL AND FINISHES:

- 1.1 ALL MATERIALS MEET TML OF 1% MAX. AND CVCM OF 0.1% MAX. WHEN TESTED IN ACCORDANCE WITH ASTM E-595.
- 1.2 REFER TO THE TE CONNECTIVITY/RAYCHEM SPECIFICATION CONTROL DRAWINGS LISTED BELOW FOR INDIVIDUAL COMPONENT DETAILS:

2. APPLICATION:

- 2.1 QUALIFIED TO TE CONNECTIVITY/RAYCHEM SPECIFICATION D-6025.
- 2.2 REFER TO TE CONNECTIVITY/RAYCHEM SPECIFICATION D-6025 FOR PERFORMANCE REQUIREMENTS.
- 2.4 THIS PRODUCT IS NOT INTENDED FOR USE IN HIGH MOISTURE ENVIRONMENTS, NOR INTENDED FOR APPLICATIONS WHERE FLUID IMMERSION IS NECESSARY.

3. TEMPERATURE:

- 3.1 OPERATING TEMPERATURE: -65°C TO +150°C CONTINUOUS.

4. WEIGHT:

- 4.1 JACK CONNECTOR KIT: 0.0218 LBS, 9.9 GRAMS (MAX).
- 4.2 PLUG CONNECTOR KIT: 0.0245 LBS, 11.1 GRAMS (MAX).

5. TERMINATION PROCEDURE:

- 5.1 TERMINATE COMPONENTS PER TE CONNECTIVITY/RAYCHEM ES61162.

INDIVIDUAL COMPONENTS	
D-621-0933/0940	CONNECTOR, TRIAXIAL, BAYONET COUPLED
D-602-0126	CONTACT, PIN, TWISTED PAIR
D-602-0126	CONTACT, SOCKET, TWISTED PAIR
B-070-84	BRAID TERMINATOR
D-600-0033	STRAIN RELIEF

Raychem Databus CUSTOMER DRAWING



TE Connectivity

DRAWN T RATZLAFF	DATE 24JUN2003	SIZE A	CAGE CODE 06090	DWG. NO. DK-621-L933/L940(-XX)	REV NC1
CAD FILE T31878A.dwg		DO NOT SCALE THIS DRAWING		SHEET 3 OF 3	