

PRODUCT NUMBER
SEE TABLE

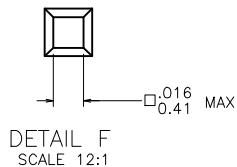
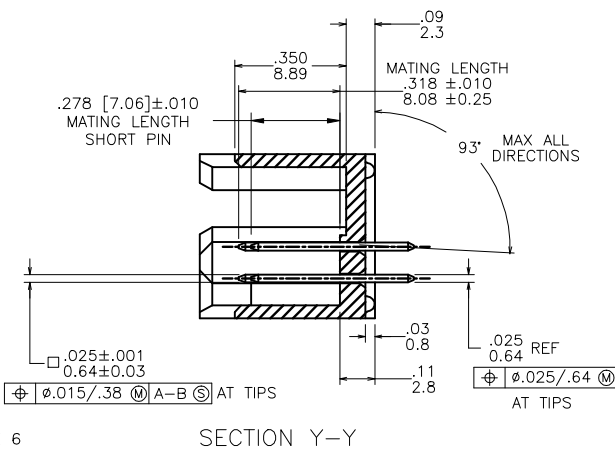
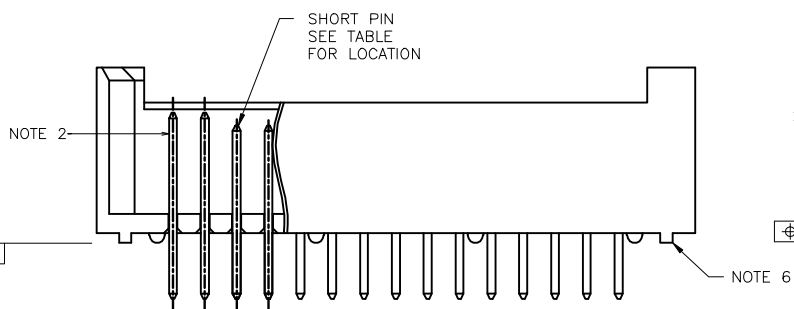
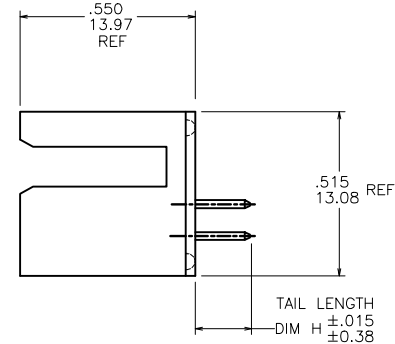
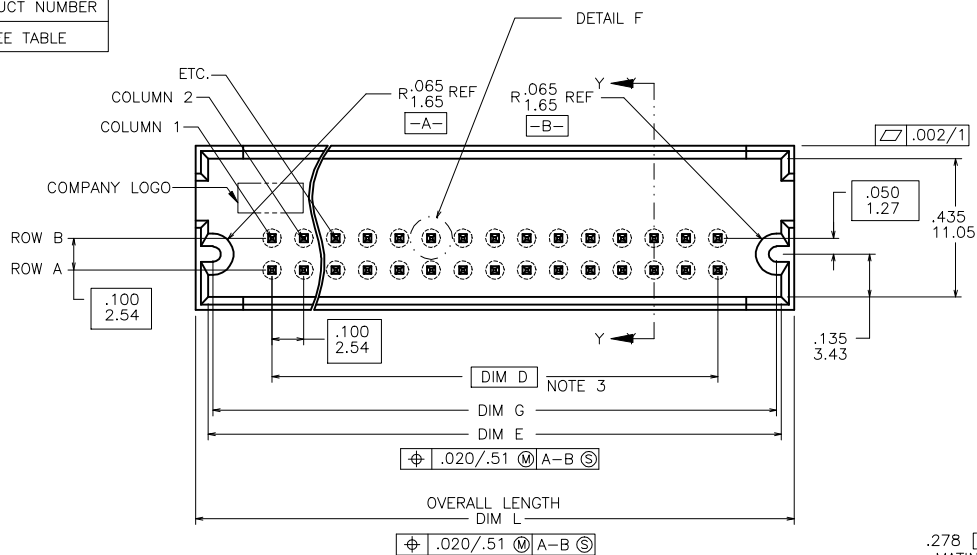

mat'l. code				surface ISO 1302 ✓ tolerance ISO 406 ISO 1101		projection INCH/MM		product family HEADERS	
tolerances unless otherwise specified				linear XX±.01/XX±.03		scale 2:1		title VERTICAL 2-ROW GUIDE PIN (SLOTTED) HEADER-FMLB	
ltr	ecn no	dr	date	angles	linear	XX±.06/XX±0.13		dwg no 10033362	
A	V03-090	DAI	8/14/03			XXX±.002/XXX±0.051		sheet 1 of 2 size A3	
B	M05-0102	MHT	5/10/05					type Product Customer Drawing	
C	M06-0289	AGS	7/29/06	0'±2'					
D	M09-0059	MHT	4/16/09	dr	D. INGRAM	8/14/03			
				engr	H. SUNDY	8/14/03			
				chr	H. SUNDY	8/14/03			
				appd	H. SUNDY	8/14/03			
sheet index	revision sheet	D	D						
		1	2						

FCJ
FCJconnect.com

Copyright FCJ

PRODUCT NUMBER NOTE 4	SIZE NOTE 4	TAIL LENGTH DIM H	DIM D	DIM G	DIM E	OVERALL LENGTH DIM L	PLATING NOTE 10	SHORT PIN LOCATION
10033362-001LF	2X18	.122/3.10	NOTE 3	.37/-.94+DIM D	.40/10.2+DIM D	.48/12.2+DIM D	30u"/.76u Au OVER 50u"/1.27u Ni	A & B - 13,14,15,16
10033362-002LF	2X18	.122/3.10	NOTE 3	.37/-.94+DIM D	.40/10.2+DIM D	.48/12.2+DIM D	30u"/.76u Au OVER 50u"/1.27u Ni	A & B - 1,2,3,8,9,10,11,12,13,14,15,16

NOTES :

- ① MOLDING MATERIAL : HI-TEMP RESIN
PER UL 94 V-0 COLOR : NATURAL
- ② PIN RETENTION TO BE 3 LBS/1.36 KG
MIN PER PIN IN EITHER DIRECTION.
- ③ DIM D =
(NO. OF COLUMNS-1) TIMES .100(ENGLISH)
(NO. OF COLUMNS-1) TIMES 2.54(METRIC)
- ④ SIZES 2X1 THROUGH 2X4 ARE NOT AVAILABLE.
- ⑤ TERMINAL MATERIAL : 3/4/HARD PHOS BRONZE ALLOY
UNS C51000
- ⑥ FLATNESS IS MEASURED FROM THE BOTTOM
OF THE END STANDOFFS.
- ⑦ PART NUMBERS WITH "LF" SUFFIX AT THE END ARE LEAD FREE.
8. THE HOUSING WILL WITHSTAND EXPOSURE TO 260°C PEAK TEMPERATURE
FOR 15 SECONDS IN A WAVE SOLDER APPLICATION WITH A 1.5mm
MINIMUM THICK CIRCUIT BOARD. SEE APPLICATION NOTES/PROCEDURES
IF THEY ARE AVAILABLE.
9. THIS PRODUCT MEETS EUROPEAN UNION DIRECTIVES AND OTHER
COUNTRY REGULATION AS DESCRIBED IN GS-22-008.
- ⑩ PLATING OPTIONS:
MAY BE EITHER GOLD OR GXT PLATED AT MANUFACTURER'S OPTION.

mat'l. code		surface ISO 1302	tolerance ISO 406 ISO 1101	projection	product family HEADERS
ltr	ecp no	dr	date	title	
D				VERTICAL 2-ROW GUIDE PIN (SLOTTED) HEADER-FMLB	
D		angles	linear	INCH/MM	scale 2:1
0'±2'					
dr	D. INGRAM	8/14/03			
engr	H. SUNDY	8/14/03			
chr	H. SUNDY	8/14/03			
appd	H. SUNDY	8/14/03			
sheet	revision				
index	sheet				
dwg no		sheet 2 of 2		size	
10033362				A3	
type		Product Customer Drawing			

form: A3

1

2

3

4

5

6



Copyright FCJ