

Plastic Point Source Infrared Emitting Diode

OP245PS



Features:

- Point source irradiance pattern
- Side-looking package for space-limited applications
- Wavelength matched to silicon’s peak response
- Higher power output than GaAs at equivalent drive currents
- Fast switching speed

Description:

Each **OP245PS** device is an infrared emitting diode with a 850 nm GaAlAs chip, molded in a clear IR-transmissive side-looking epoxy package. This package makes these devices ideal for PC Board mounted slotted switches and for mounted interrupt detectors.

The stable forward V_f vs T_A characteristic make them suitable for applications that have limited voltage, such as battery operation; whereas, the low T_R/T_F makes them ideal for high-speed operations.

Please refer to Application Bulletin 210 for additional thermal design information.

Applications:

- Space-limited applications
- PC Board mounted slotted switch
- Mounted interrupt detector
- High-speed applications

Ordering Information				
Part Number	LED Peak Wavelength	Lens Type	Total Beam Angle	Lead Length (min.)
OP245PS	850 nm	Recessed Dome	±18°	0.5" / 12.7 mm

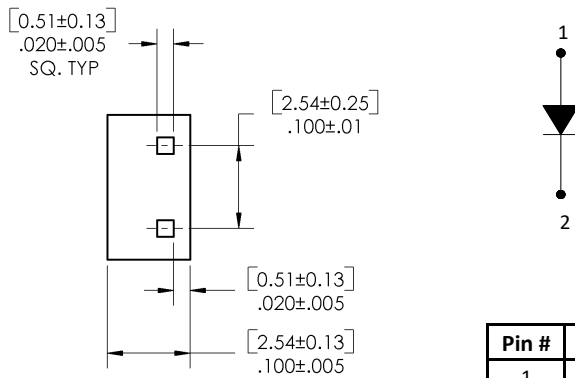
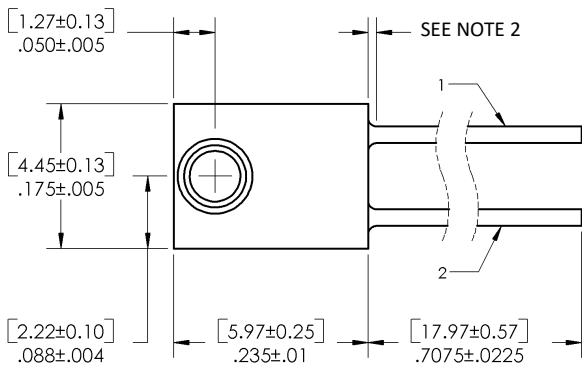

Pin #	LED
1	Anode
2	Cathode

NOTES:

1. OUTSIDE DISCRETE SHELL IS POLYSULFONE.
2. MAX ALLOWABLE EPOXY MENSCLUS IS 0.010".



CONTAINS POLYSULFONE
 To avoid stress cracking, we suggest using ND Industries' **Vibra-Tite** for thread-locking. **Vibra-Tite** evaporates fast without causing structural failure in OPTEK'S molded plastics.

General Note
 TT Electronics reserves the right to make changes in product specification without notice or liability. All information is subject to TT Electronics' own data and is considered accurate at time of going to print.

TT Electronics | OPTEK Technology
 2900 E. Plano Pkwy, Plano, TX 75074 | Ph: +1 972 323 2200
 www.ttelectronics.com | sensors@ttelectronics.com

Electrical Specifications

Absolute Maximum Ratings ($T_A = 25^\circ\text{C}$ unless otherwise noted)

Storage and Operating Temperature Range	-40° C to +100° C
Reverse Voltage	2.0 V
Continuous Forward Current	50 mA
Peak Forward Current	1.0 A
Lead Soldering Temperature [1/16 inch (1.6 mm) from case for 5 seconds with soldering iron] ⁽¹⁾	260° C
Power Dissipation ⁽²⁾	100 mW

Electrical Characteristics ($T_A = 25^\circ\text{C}$ unless otherwise noted)

SYMBOL	PARAMETER	MIN	TYP	MAX	UNITS	TEST CONDITIONS
Input Diode						
$E_{E(APT)}^{(3)}$	Apertured Radiant Incidence	0.12	-	0.8	mW/cm ²	$I_F = 20\text{ mA}$
V_F	Forward Voltage	1.2	-	1.7	V	$I_F = 20\text{ mA}$
I_R	Reverse Current	-	10	-	μA	$V_R = 2\text{ V}$
λ_P	Wavelength at Peak Emission	-	850	-	nm	$I_F = 20\text{ mA}$
B	Spectral Bandwidth between Half Power Points	-	50	-	nm	$I_F = 20\text{ mA}$
θ_{HP}	Emission Angle at Half Power Points	-	$\pm 18^\circ$	-	Degree	$I_F = 20\text{ mA}$
t_r	Output Rise Time	-	10	-	ns	$I_{F(PK)} = 20\text{ mA}$, PW = 10 μs , D.C. = 10%
t_f	Output Fall Time	-	10	-	ns	$I_{F(PK)} = 20\text{ mA}$, PW = 10 μs , D.C. = 10%

Notes:

1. RMA flux is recommended. Duration can be extended to 10 seconds maximum when flow soldering. A maximum of 20 grams force may be applied to the leads when soldering.
2. Derate linearly 1.07 mW/° C above 25° C.
3. $E_{E(APT)}$ is a measurement of the average apertured radiant energy incident upon a sensing area 0.180" (4.57 mm) in diameter perpendicular to and centered on the mechanical axis of the lens and 0.653" (16.6 mm) from the lens tip. $E_{E(APT)}$ is not necessarily uniform within the measured area.

General Note

TT Electronics reserves the right to make changes in product specification without notice or liability. All information is subject to TT Electronics' own data and is considered accurate at time of going to print.

TT Electronics | OPTEK Technology
2900 E. Plano Pkwy, Plano, TX 75074 | Ph: +1 972 323 2200
www.ttelectronics.com | sensors@ttelectronics.com

Plastic Point Source Infrared Emitting Diode

OP245PS



Typical Performance

OP245PS

Forward Current vs Forward Voltage vs Temperature

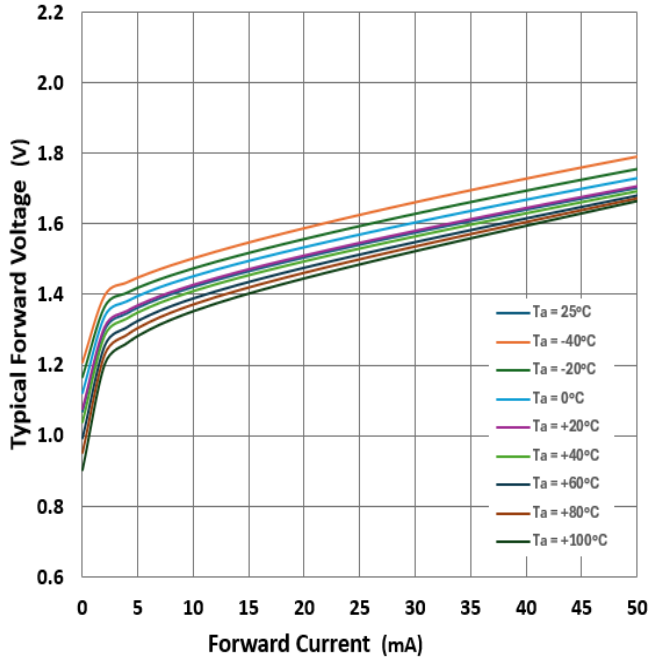

Optical Power vs Forward Current vs Temperature

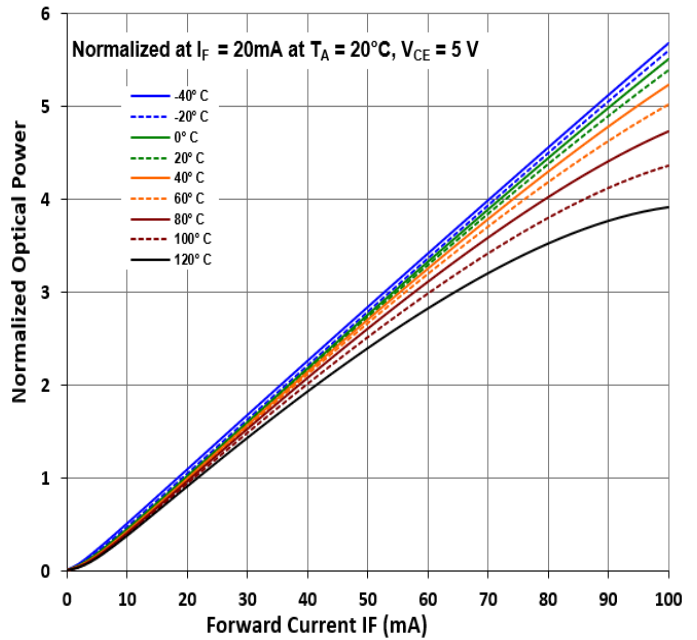

Distance vs Power vs Forward Current

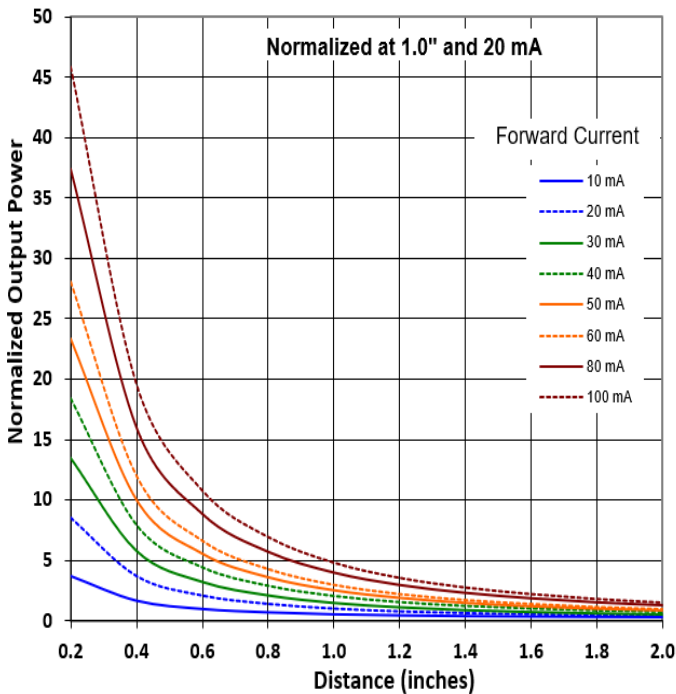

Beam Angle

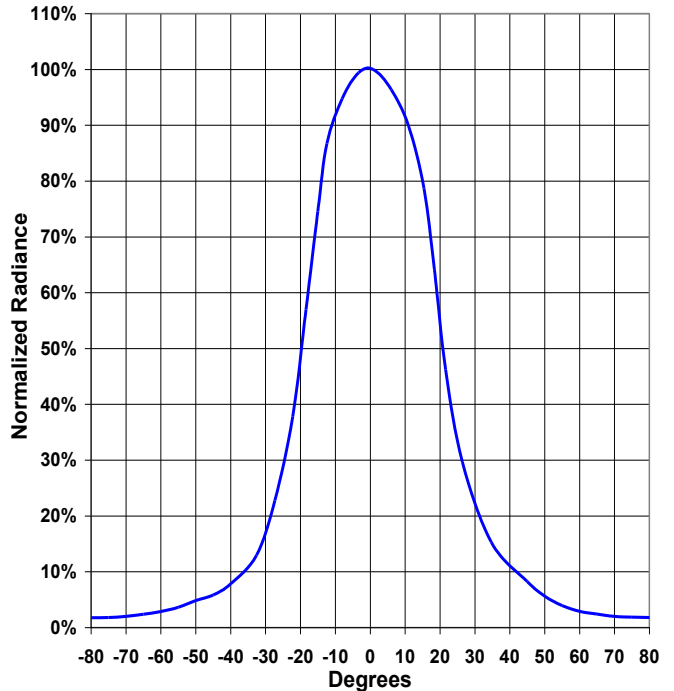

General Note

TT Electronics reserves the right to make changes in product specification without notice or liability. All information is subject to TT Electronics' own data and is considered accurate at time of going to print.

TT Electronics | OPTEK Technology
 2900 E. Plano Pkwy, Plano, TX 75074 | Ph: +1 972 323 2200
 www.ttelectronics.com | sensors@ttelectronics.com